

### General Description

The AAT3560 Series of PowerManager™ products is a member of AATI's Total Power Management IC™ (TPMIC™) product family. These voltage detectors are ideal for monitoring voltage supplies in portable systems, where extended battery life is critical. They provide a low cost, reliable solution by eliminating several external components. The AAT3560 series operates by monitoring the system power supply voltage. When the input voltage drops below a fixed threshold, the device output changes state depending upon configuration. When the input voltage rises above the threshold, the device output reverts back to the previous state. The AAT3560 series are available with three different output stages: AAT3560 push-pull active high output, AAT3562 push-pull active low output and AAT3564 open drain active low output.

The quiescent supply current is extremely low, typically 1µA, making it ideal for portable battery operated equipment.

The AAT3560/2/4 are available in a 3 pin SOT-23 package and are specified over -40 to 85°C operating temperature range..

### Features

- 1.2V to 5.5V Input voltage range
- Operates down to 1.2V
- Extremely low quiescent current: less than 2µA
- High accuracy detection threshold: ±1.5%
- Monitor Power Supply Voltages
  - Fixed thresholds from 2.2V to 4.6V
- Available output configurations:
  - Open-drain output
  - CMOS active high output
  - CMOS active low output
- Temp range -40 to 85°C
- 3 pin SOT-23 package

### Applications

- Portable Electronics
- Battery Packs
- Battery Charger Circuits
- Data Acquisition Systems
- Power Supplies
- Notebook Computers
- Intelligent Instruments

### Typical Application

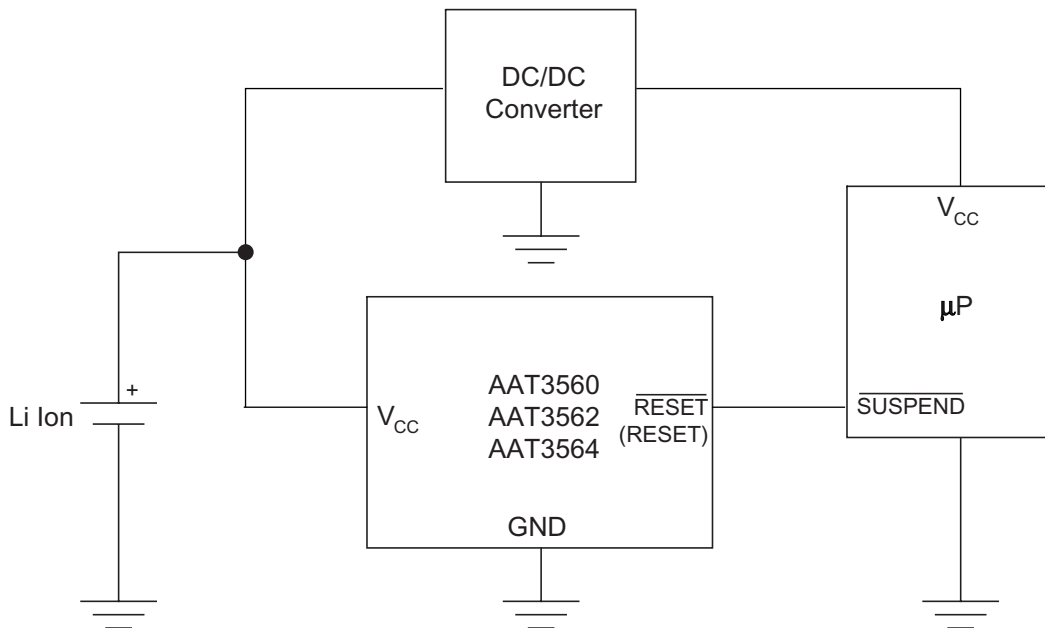

### Pin Descriptions

#### AAT3560, 3562, 3564 (SOT23-3)

Pin #	Symbol	Function
1	GND	Ground
2	RESET ( $\overline{\text{RESET}}$ )	Reset output. See table below for output configurations.
3	V <sub>CC</sub>	Supply Voltage (+1.2V to +5.5V)

### Part Number Descriptions

SOT23-3 Part Number	Part Description
AAT3560	RESET Push Pull Active High
AAT3562	$\overline{\text{RESET}}$ Push Pull Active Low
AAT3564	$\overline{\text{RESET}}$ Open Drain, Active Low

### Pin Configuration

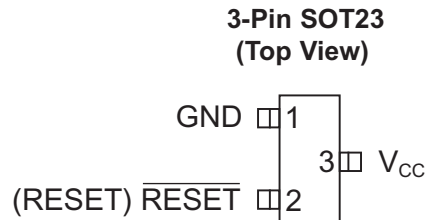

### Absolute Maximum Ratings ( $T_A=25^\circ\text{C}$ unless otherwise noted)

Symbol	Description	Value	Units
$V_{CC}$	$V_{CC}$ to GND	-0.3 to 5.5	V
$V_{RESET}$	RESET to GND (Push-Pull Output)	-0.3 to $V_{CC}+0.3$	V
	$\overline{RESET}$ to GND (Open Drain Output)	-0.3 to 5.5	
$I_{MAX}$	Maximum Continuous Input Current	20	mA
$I_{RESET}$	RESET/RESET Current	20	mA
$T_J$	Operating Junction Temperature Range	-40 to 150	$^\circ\text{C}$
$T_{LEAD}$	Maximum Soldering Temperature (at Leads) for 10s	300	$^\circ\text{C}$

Note: Stresses above those listed in Absolute Maximum Ratings may cause permanent damage to the device. Functional operation at conditions other than the operating conditions specified is not implied. Only one Absolute Maximum rating should be applied at any one time.

### Thermal Information

Symbol	Description	Value	Units
$\Theta_{JA}$	Maximum Thermal Resistance <sup>1</sup>	200	$^\circ\text{C}/\text{W}$
$P_D$	Maximum Power Dissipation <sup>1</sup>	320	mW

Note 1: Mounted on FR4 board.

**Electrical Characteristics** ( $V_{IN} = 5\text{V}$ ,  $T_A = -40$  to  $85^\circ\text{C}$  unless otherwise noted. Typical values are at  $T_A=25^\circ\text{C}$ ,  $V_{CC} = 5\text{V}$  for 4.63/4.38V versions,  $V_{CC} = 3.3\text{V}$  for 3.08/2.93V versions,  $V_{CC} = 3.0\text{V}$  for 2.63V version and  $V_{CC} = 2.5\text{V}$  for 2.32/2.2V versions )

Symbol	Description	Conditions	Min	Typ	Max	Units
$V_{CC}$	Operation Voltage	$T_A = 0$ to $70^\circ\text{C}$	1.0		5.5	V
		$T_A = -40$ to $85^\circ\text{C}$	1.2		5.5	
$I_Q$	Quiescent Current	$V_{CC} = 3\text{V}$		0.85	2	$\mu\text{A}$
		$V_{CC} = 5.5\text{V}$		1.05	3	
$V_{TH}$	RESET Threshold (Table 1)	$T_A = 25^\circ\text{C}$	$V_{TH} - 1.5\%$	$V_{TH}$	$V_{TH} + 1.5\%$	V
		$T_A = -40^\circ\text{C}$ to $+85^\circ\text{C}$	$V_{TH} - 2.5\%$	$V_{TH}$	$V_{TH} + 2.5\%$	
$dV_{TH}/^\circ\text{C}$	RESET Threshold Tempco			40		ppm/ $^\circ\text{C}$
$V_{OL}$	$\overline{RESET}$ Low Output Voltage AAT3562, AAT3564	$I_{SINK} = 1.6\text{mA}$ , $V_{CC} > 2.1\text{V}$ , RESET asserted			0.3	V
		$I_{SINK} = 100\mu\text{A}$ , $V_{CC} > 1.2\text{V}$ , RESET asserted			0.4	V
$V_{OH}$	RESET High Output Voltage, AAT3562	$I_{SOURCE} = 800\mu\text{A}$	$V_{CC} - 1.5$			V
$V_{OL}$	RESET Low Output Voltage AAT3560	$I_{SINK} = 1.2\text{mA}$ , $V_{CC} > 1.2\text{V}$ , RESET not asserted			0.3	V
		$I_{SINK} = 3.2\text{mA}$ , $V_{CC} > 4.5\text{V}$ , RESET not asserted			0.4	V
$V_{OH}$	RESET High Output Voltage AAT3560	$I_{SOURCE} = 500\mu\text{A}$ , $V_{CC} > 2.1\text{V}$ , RESET asserted	$0.8V_{CC}$			V
		$I_{SOURCE} = 50\mu\text{A}$ , $V_{CC} > 1.2\text{V}$ , RESET asserted	$0.8V_{CC}$			V
$I_{DOFF}$	$\overline{RESET}$ Leakage Current, AAT3564	$V_{CC} > V_{TH}$			1	$\mu\text{A}$

### Typical Characteristics (Unless otherwise noted, $V_{IN} = 5V$ , $T_A = 25^\circ C$ )

**Supply Current vs. Temperature**

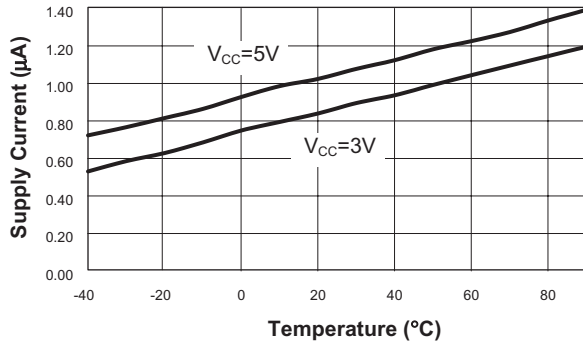

**Normalized Reset Threshold vs. Temperature**

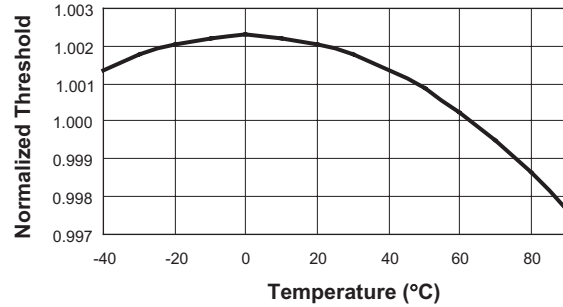

**Power-Down Reset Propagation Delay vs. Temperature**

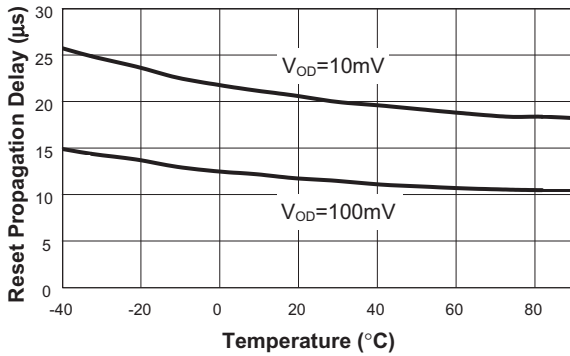

**Maximum Transient Duration vs. Reset Threshold Overdrive**

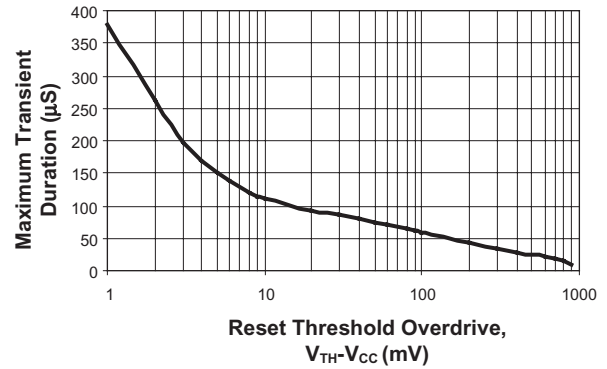

### Functional Block Diagram

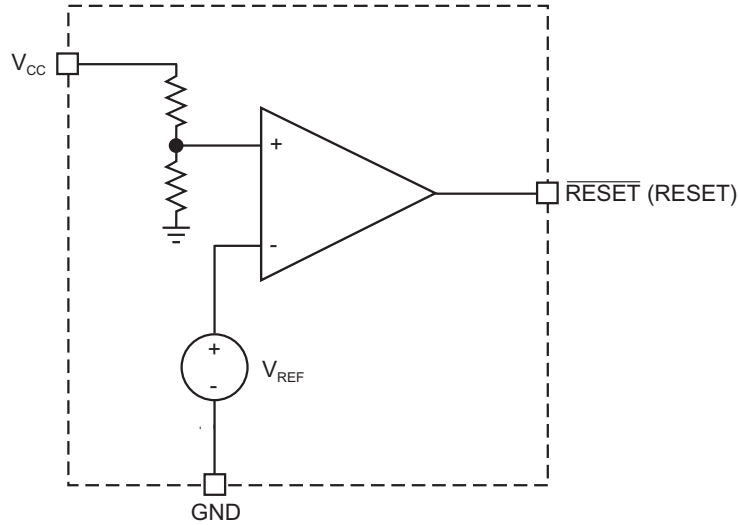

### Functional Description

#### General

The AAT3560 series of Nanopower voltage detectors, monitors a system power supply and asserts an output signal (Low for AAT3562, AAT3564 and High for AAT3560) when the supply voltage drops

below a factory programmed threshold voltage. The output signal will remain valid until the input voltage falls below the Minimum Operating Voltage of 1V. Below this value the output voltage is undefined. When the input voltage rises above the factory programmed threshold, the output signal will resume its inactive state.

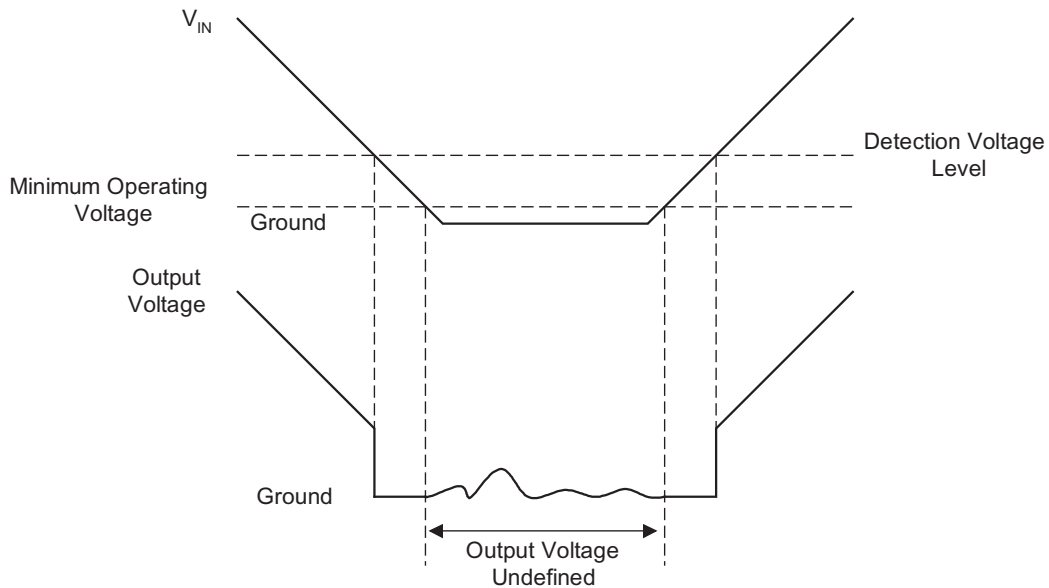

Figure 1. AAT3562 Timing Diagram

### Factory Trimmed Reset Thresholds\* and Ordering Information Table 1

Ordering Part Number	Package Marking Code	Reset Threshold Voltage, $V_{TH}$ (V)				
		$T_A = 25^\circ\text{C}$			$T_A = -40 \text{ to } +85^\circ\text{C}$	
		MIN	TYP	MAX	MIN	MAX
AAT3560IGY-2.20-T1 AAT3562IGY-2.20-T1 AAT3564IGY-2.20-T1		2.167	2.200	2.233	2.145	2.255
AAT3560IGY-2.30-T1 AAT3562IGY-2.30-T1 AAT3564IGY-2.30-T1		2.266	2.300	2.335	2.243	2.358
AAT3560IGY-2.40-T1 AAT3562IGY-2.40-T1 AAT3564IGY-2.40-T1		2.364	2.400	2.436	2.340	2.460
AAT3560IGY-2.50-T1 AAT3562IGY-2.50-T1 AAT3564IGY-2.50-T1		2.463	2.500	2.538	2.438	2.563
AAT3560IGY-2.60-T1 AAT3562IGY-2.60-T1 AAT3564IGY-2.60-T1		2.561	2.600	2.639	2.535	2.665
AAT3560IGY-2.70-T1 AAT3562IGY-2.70-T1 AAT3564IGY-2.70-T1		2.660	2.700	2.741	2.633	2.768
AAT3560IGY-2.80-T1 AAT3562IGY-2.80-T1 AAT3564IGY-2.80-T1		2.758	2.800	2.842	2.730	2.870
AAT3560IGY-2.90-T1 AAT3562IGY-2.90-T1 AAT3564IGY-2.90-T1		2.857	2.900	2.944	2.828	2.973
AAT3560IGY-3.00-T1 AAT3562IGY-3.00-T1 AAT3564IGY-3.00-T1		2.955	3.000	3.045	2.925	3.075
AAT3560IGY-3.10-T1 AAT3562IGY-3.10-T1 AAT3564IGY-3.10-T1		3.054	3.100	3.147	3.023	3.178
AAT3560IGY-3.20-T1 AAT3562IGY-3.20-T1 AAT3564IGY-3.20-T1		3.152	3.200	3.248	3.120	3.280
AAT3560IGY-3.30-T1 AAT3562IGY-3.30-T1 AAT3564IGY-3.30-T1		3.251	3.300	3.350	3.218	3.383
AAT3560IGY-3.40-T1 AAT3562IGY-3.40-T1 AAT3564IGY-3.40-T1		3.349	3.400	3.451	3.315	3.485
AAT3560IGY-3.50-T1 AAT3562IGY-3.50-T1 AAT3564IGY-3.50-T1		3.448	3.500	3.553	3.413	3.588

### Factory Trimmed Reset Thresholds\* and Ordering Information Table 1

Ordering Part Number	Package Marking Code	Reset Threshold Voltage, $V_{TH}$ (V)				
		$T_A = 25^\circ\text{C}$			$T_A = -40 \text{ to } +85^\circ\text{C}$	
		MIN	TYP	MAX	MIN	MAX
AAT3560IGY-3.60-T1 AAT3562IGY-3.60-T1 AAT3564IGY-3.60-T1		3.546	3.600	3.654	3.510	3.690
AAT3560IGY-3.70-T1 AAT3562IGY-3.70-T1 AAT3564IGY-3.70-T1		3.644	3.700	3.755	3.607	3.792
AAT3560IGY-3.80-T1 AAT3562IGY-3.80-T1 AAT3564IGY-3.80-T1		3.743	3.800	3.857	3.705	3.895
AAT3560IGY-3.90-T1 AAT3562IGY-3.90-T1 AAT3564IGY-3.90-T1		3.841	3.900	3.958	3.802	3.997
AAT3560IGY-4.00-T1 AAT3562IGY-4.00-T1 AAT3564IGY-4.00-T1		3.940	4.000	4.060	3.900	4.100
AAT3560IGY-4.10-T1 AAT3562IGY-4.10-T1 AAT3564IGY-4.10-T1		4.038	4.100	4.161	3.997	4.202
AAT3560IGY-4.20-T1 AAT3562IGY-4.20-T1 AAT3564IGY-4.20-T1		4.137	4.200	4.263	4.095	4.305
AAT3560IGY-4.30-T1 AAT3562IGY-4.30-T1 AAT3564IGY-4.30-T1		4.235	4.300	4.364	4.192	4.407
AAT3560IGY-4.40-T1 AAT3562IGY-4.40-T1 AAT3564IGY-4.40-T1		4.334	4.400	4.466	4.290	4.510
AAT3560IGY-4.50-T1 AAT3562IGY-4.50-T1 AAT3564IGY-4.50-T1		4.432	4.500	4.567	4.387	4.612
AAT3560IGY-4.60-T1 AAT3562IGY-4.60-T1 AAT3564IGY-4.60-T1		4.531	4.600	4.669	4.485	4.715

Contact Local Sales Office for custom trimmed options.

### Package Information

SOT23-3

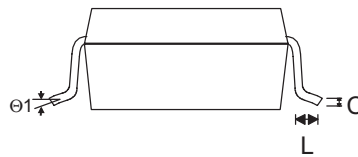
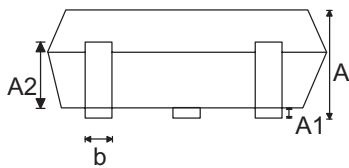
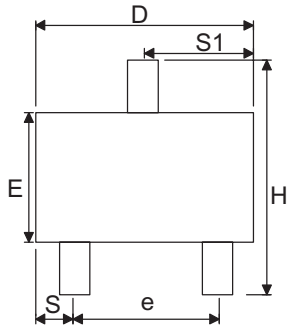

Dim	Millimeters		Inches	
	Min	Max	Min	Max
A	.887	1.02	0.034	.040
A1	.013	0.10	0.0005	.004
A2	-	-	-	-
b	0.37	0.51	0.015	0.020
C	0.085	0.180	0.003	0.007
D	2.80	3.04	0.110	0.120
E	1.20	1.40	0.047	0.055
e	1.78	2.05	0.070	0.080
H	2.10	2.64	0.083	0.104
L	-	0.69	-	0.027
S	0.45	0.60	0.018	0.024
S1	0.89	1.03	0.035	0.040
$\theta 1$	0°	8°	0°	8°

Note:

1. PACKAGE BODY SIZE EXCLUDE MOLD FLASH PROTRUSIONS OR GATE BURRS.
2. TOLERANCE  $\pm 0.1000$  mm (4mi) UNLESS OTHERWISE SPECIFIED
3. COPLANARITY: 0.1000
4. DIMENSION L IS MEASURED IN GAGE PLANE