

General Description

The AAT9123 30V N-Channel Power MOSFET is a member of AnalogicTech's TrenchDMOS™ product family. Using the ultra-high density proprietary TrenchDMOS technology, this product demonstrates high power handling and small size.

Features

- $V_{DS(MAX)} = 30V$
- $I_{D(MAX)} = 10A @ 25^{\circ}C$
- Low $R_{DS(ON)}$:
 - $13.5 m\Omega @ V_{GS} = 10V$
 - $20 m\Omega @ V_{GS} = 4.5V$

Applications

- DC-DC converters for mobile CPUs
- Battery-powered portable equipment
- High power density DC-DC converters
- Point-of-use Power Supplies

SOP8 Package

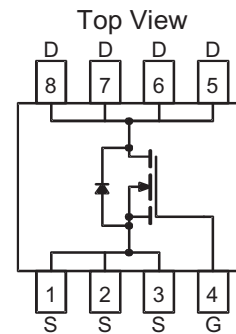

Absolute Maximum Ratings ($T_A=25^{\circ}C$ unless otherwise noted)

Symbol	Description	Value	Units
V_{DS}	Drain-Source Voltage	30	V
V_{GS}	Gate-Source Voltage	± 20	
I_D	Continuous Drain Current @ $T_J=150^{\circ}C$ ¹	$T_A = 25^{\circ}C$	± 10
		$T_A = 70^{\circ}C$	± 8
I_{DM}	Pulsed Drain Current	± 52	A
I_S	Continuous Source Current (Source-Drain Diode) ¹	2.25	
P_D	Maximum Power Dissipation ¹	$T_A = 25^{\circ}C$	2.5
		$T_A = 70^{\circ}C$	1.6
T_J, T_{STG}	Operating Junction and Storage Temperature Range	-55 to 150	$^{\circ}C$

Thermal Characteristics

Symbol	Description	Value	Units
$R_{\theta JA}$	Maximum Junction-to-Ambient ¹	50	$^{\circ}C/W$
$R_{\theta JC}$	Maximum Junction-to-Case	26	$^{\circ}C/W$

Note 1: Mounted on 1" x 1" FR4 Copper Board. 10 sec pulse width.

Electrical Characteristics ($T_J=25^\circ\text{C}$ unless otherwise noted)

Symbol	Description	Conditions	Min	Typ	Max	Units
DC Characteristics						
BV_{DSS}	Drain-Source Breakdown Voltage	$V_{GS}=0V, I_D=250\mu A$	30			V
$R_{DS(ON)}$	Drain-Source ON-Resistance ²	$V_{GS}=10V, I_D=10A$		10	13.5	m Ω
		$V_{GS}=4.5V, I_D=8A$		16	20	
$I_{D(ON)}$	On-State Drain Current ²	$V_{GS}=10V, V_{DS}=5V$ (Pulsed)	52			A
$V_{GS(th)}$	Gate Threshold Voltage	$V_{GS}=V_{DS}, I_D=250\mu A$	1.0			V
I_{GSS}	Gate-Body Leakage Current	$V_{GS}=\pm 20V, V_{DS}=0V$			± 100	nA
I_{DSS}	Drain Source Leakage Current	$V_{GS}=0V, V_{DS}=30V$			1	μA
		$V_{GS}=0V, V_{DS}=30V, T_J=55^\circ C$			5	
g_{fs}	Forward Transconductance ²	$V_{DS}=15V, I_D=10A$		25		S
Dynamic Characteristics ³						
Q_G	Total Gate Charge	$V_{DS}=15V, I_D=15A, V_{GS}=5V$		20	28	nC
Q_{GT}	Total Gate Charge	$V_{DS}=15V, I_D=15A, V_{GS}=10V$		38	56	nC
Q_{GS}	Gate-Source Charge	$V_{DS}=15V, I_D=15A, V_{GS}=10V$		7		nC
Q_{GD}	Gate-Drain Charge	$V_{DS}=15V, I_D=15A, V_{GS}=10V$		5		nC
$t_{D(ON)}$	Turn-ON Delay	$V_{DD}=15V, V_{GS}=5V, R_D=1.5\Omega, R_G=6\Omega$		14	28	ns
t_R	Turn-ON Rise Time	$V_{DD}=15V, V_{GS}=5V, R_D=1.5\Omega, R_G=6\Omega$		10	20	ns
$t_{D(OFF)}$	Turn-OFF Delay	$V_{DD}=15V, V_{GS}=5V, R_D=1.5\Omega, R_G=6\Omega$		65	100	ns
t_F	Turn-OFF Fall Time	$V_{DD}=15V, V_{GS}=5V, R_D=1.5\Omega, R_G=6\Omega$		53	70	ns
Source-Drain Diode Characteristics						
V_{SD}	Source-Drain Forward Voltage ²	$V_{GS}=0, I_S=2.25A$			1.1	V
I_S	Continuous Diode Current	$T_A=25^\circ C$			2.25	A

Note 2: Pulse test: Pulse Width = 300 μs

Note 3: Guaranteed by design. Not subjected to production testing.

Typical Characteristics

($T_J=25^\circ\text{C}$ unless otherwise noted)

Forward Characteristics

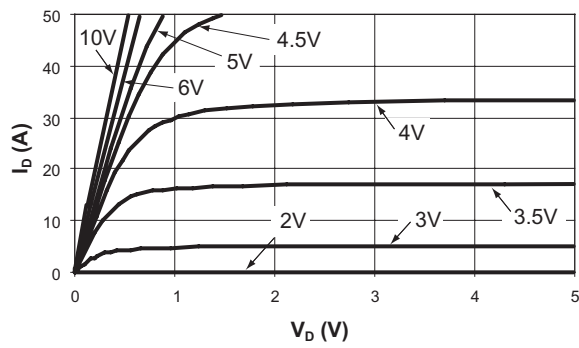

Normalized $R_{DS(ON)}$

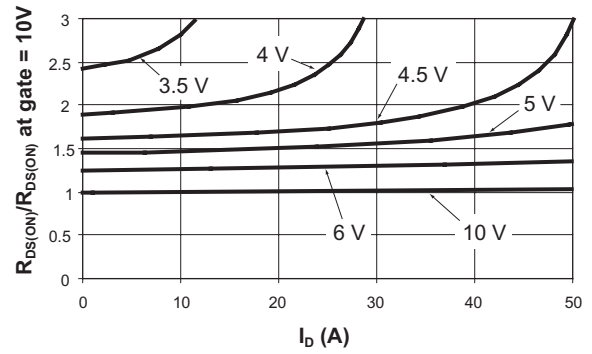

$R_{DS(ON)}$ vs. V_G

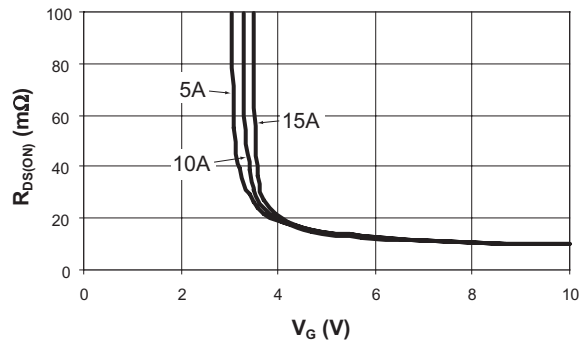

Transfer

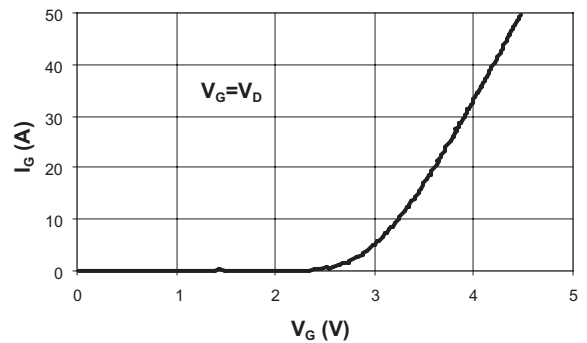

Source to Drain Voltage

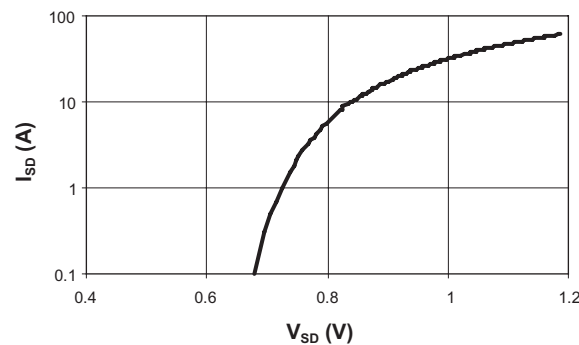

Gate Charge Characteristics

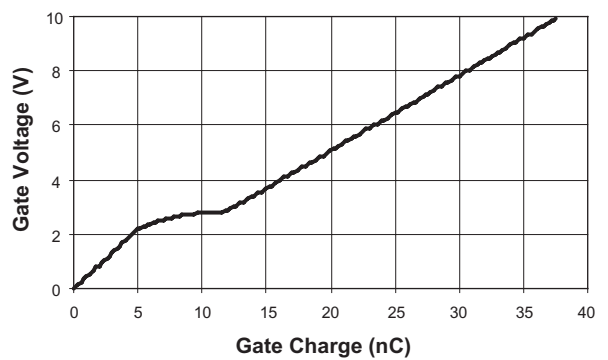

Ordering Information

Package	Marking	Part Number	
		Bulk	Tape and Reel
SOP-8		AAT9123IAS-B1	AAT9123IAS-T1

Package Information

SOP-8

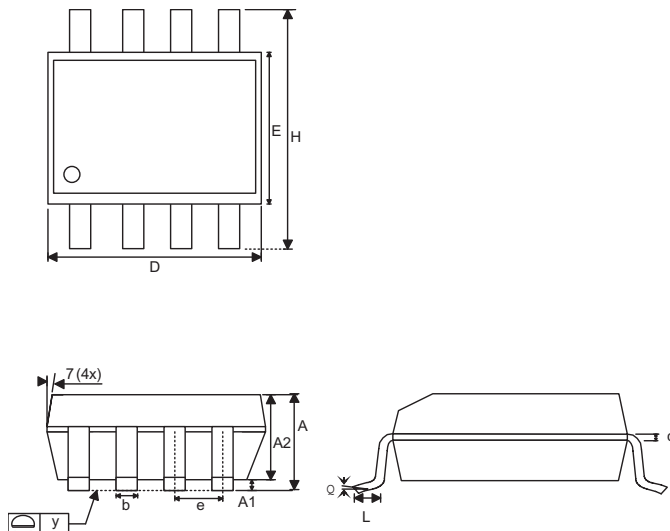

Dim	Millimeters		Inches	
	Min	Max	Min	Max
A	1.35	1.75	0.053	0.069
A1	0.10	0.25	0.004	0.010
A2	1.45		0.057	
B	0.33	0.51	0.013	0.020
C	0.19	0.25	0.007	0.010
D	4.80	5.00	0.189	0.197
E	3.80	4.00	0.150	0.157
e	1.27		0.050	
H	5.80	6.20	0.228	0.244
L	0.40	1.27	0.016	0.050
Y	0.00	0.10	0.000	0.004
θ1	0°	8°	0°	8°

Note:

1. PACKAGE BODY SIZES EXCLUDE MOLD FLASH PROTRUSIONS OR GATE BURRS.
2. TOLERANCE 0.1000mm (4mil) UNLESS OTHERWISE SPECIFIED
3. COPLANARITY: 0.1000mm
4. DIMENSION L IS MEASURED IN GAGE PLANE.
5. CONTROLLING DIMENSION IS MILLIMETER; CONVERTED INCH DIMENSIONS ARE NOT NECESSARILY EXACT.