



35 South Service Road • Plainview, NY 11803
TEL: 516 694-6700 • FAX: 516 694-6715

The Future in Microelectronics

CIRCUIT TECHNOLOGY

APPLICATION NOTE #108

CT2577 / 79
SmaRT Series
Users Guide

Point of Contact:
John Vanchieri
Tel: (516) 752-2484

Table of Contents

<u>Contents</u>	<u>Page</u>
Signal Descriptions.....	3-7
MIL-STD-1553 Bus Interface Signals	
Hard Wired Interface Signals	
MIL-STD-1760 Signals	
Bus Interface Signals	
RT Status Word Discrete Inputs	
RT Discrete Signals	
BC Discrete Signals	
Remote Terminal (RT) Mode.....	8-21
Sequence of Operation	
Receive Command	
Message Illegalization	
MIL-STD-1760 Features	
1760 Header Word	
Signals that Indicate Checksum Failure	
Block Transfer Logic	
READ (Receive)	
DMA Transfer Times	
Transmit Command	
MIL-STD-1760 Features	
Signals that Indicate Checksum Failure	
Block Transfer Logic / DMA Transfer Times	
WRITE	
Changing the Status Word Bits	
Device Status	
Bit Register	
Data Storage and Retrieval in Ram	
Sample Software Code	
Retriving or Loading Data to Ram	
Self Test	
Basic Operation	
Detailed Operation	
Summary of Operation	
CT2577 /79 RT/BT Memory Map Breakdown	22
RT/BT Device Memory Map Code Breakdown Description.....	23-29
RT Status Word Control Sets	
BC Control Area	
RT/RX BC/TX Mode Area 00 - SA 00 (0) and BC Control	
30 RT Receive / BC Transmit Subaddresses - SA 01-1E (1-30)	
RT/RX BC/TX Mode Area - SA 1F (31)	
RT/BC Control Area	
RT/BC Block Transfer Logic (BTL) Control and Self Test Control	
RT/TX BC/RX Mode Area - SA 00 (0)	
30 RT Transmit / BC Receive Subaddresses -SA 01-1E (1-30)	
RT/TX BC/RX Mode Area - SA 1F (31)	
Broadcast RT/RX BC/TX Mode Area - SA 00 (0)	
30 Broadcast RT Receive / BC Transmit Subaddresses - SA 01-1E (1-30)	
Broadcast RT/RX BC/TX Mode Area 1F - SA 1F (31)	
CT2577 /79 Part Ordering Information	30-34
CT2577 - MIL-STD-1553 / 1760 Bus Controller / Remote Terminal	
CT2579 - McAir Bus Controller / Remote Terminal	
CT2577 /79 Pinouts.....	35-41
CT2577-01-xx-F84 - 84 pin Quad Flatpack	
CT2577-11-xx-F84 - 84 pin Quad Flatpack	
CT2579-01-xx-F84 - 84 pin Quad Flatpack	
CT2579-11-xx-F84 - 84 pin Quad Flatpack	
CT2577-10-xx-P119 - 110 Pin Grid Array	
CT2579-10-xx-P119 - 110 Pin Grid Array	

Signal Descriptions

MIL-STD-1553 Bus Interface Signals

Data0(Bus) Connect to positive side of the external databus transformer for Bus 0

Ndata0(Bus) Connect to negative side of the external databus transformer for Bus 0

Data1(Bus) Connect to positive side of the external databus transformer for Bus 1

Ndata1(Bus) Connect to negative side of the external databus transformer for Bus 1

Hard Wired Interface Signals

AddrA-E Remote Terminal address inputs for the unit. ADDR A is the least significant bit and ADDR E is the most significant bit. RT Address inputs for the unit. AddrA is the LSB, AddrE is the MSB.

AddrP Parity Bit for the RT Address inputs. AddrP must be set to ODD parity

MACAIR This signal sets the unit to respond with a status word within 4 uS (dead bus time) while in Remote Terminal mode. Subaddress 1F is also enabled to be a valid subaddress for data.

Normally subaddress 00 and 1F are reserved for mode codes.

"1" = 4 uS dead bus response time, subaddress 1F used for data.

"0" = 12 uS response time, subaddress 1F used for mode codes.

NBIT16 Select 8 or 16 bit subsystem data interface. In 8 bit mode only the lower 8 bits of the databus (DATA 0-7) are used for all data transfers. If left open circuit the device will default to 16 bit mode.

"0" = 16 Bit Mode

"1" = 8 Bit Mode

VME Select VME or MULTIBUS subsystem interface. If left open circuit the device will default to VME mode.

"0" = Multibus Mode

"1" = VME Mode

*WRAPEN Select Remote Terminal wrap around to subaddress 1E. For this test to work correctly the unit must be in RT mode. The Bus Controller sends data to subaddress 1E which remains in the data buffer memory and is available to be sent back on the very next command by the Bus Controller. The data in the data buffer memory in this mode does not get transferred to the main RAM. If the very next command is not a transmit command to subaddress 1E, the data buffer memory is flushed and will respond normally to the next set of commands. If the wrap around test is enabled, data to subaddress 1E must be transferred in the correct sequence.

"0" = Normal Mode

"1" = Wrap Around Mode

MIL-STD-1760 Signals

NENCHK Enables / Disables the internal hardware checksum generation and validation for both Remote Terminal and Bus Controller. When enabled, the circuitry will check all

incoming data for correct checksum and generate the correct checksum word for an outgoing data transfer.

"0" input to this pin ENABLES the checksum circuitry.

"1" input to this pin Disables the checksum circuitry.

NVALCHK Latched version of the STATUS signal. NVALCHK is latched on the falling edge of NCMDSTRB (RT) or NSTSTRB (BC) and will remain stable until the next NCMDSTRB or NSTSTRB.

"0" output to this pin means the checksum was VALID.

"1" output to this pin means the checksum was NOT VALID.

STATUS Open drain output will toggle high or low on each incoming data word from the 1553 databus provided NENCHK is enabled. When the last data word is received the STATUS line is sampled by the protocol circuitry to determine if the checksum for the message is valid. At the end of the message, if STATUS is low then the checksum is not valid. This STATUS signal can be wired to several different pins to customise the units response to a checksum failure. STATUS can be wired to signals such as NILLCMD and NSR which would cause the message to be illegalised and set Service Request bit in the Status.

NHDR In MIL-STD-1760, the first data word of a message is defined as a Header word. The NHDR signal indicates the presence of the Header word on the T0-T15 highway as it is received. The user can also read the Header word from RAM.

"0" on this pin means the Header Word is on the T0-15 Bus

STREL When the store is released from the aircraft all the Remote Terminal address inputs go high causing signal STREL to go high

LA Enables the Latched Address Option. Normally, the RT address lines are constantly monitored and compared to the incoming Command Word. When enabled, the RT address lines levels are internally latched every time the unit is reset. The latched RT address information is then compared to the incoming Command Word. This latched address function complies with the requirements of MIL-STD-1760.

"0" on this pin means the RT address lines are NOT latched

"1" on this pin means the RT address lines are latched

Bus Interface Signals

ADIN0-11 12 bit address input to the unit specifying what location the user will be accessing in the RAM / registers. These address inputs are inverted when the Multibus interface is selected.

BCNRT Indicates what mode the unit is in.

"0" = RT Mode

"1" = BC Mode

NCARDEN Used as a Device Select. Signal to indicate the processor is addressing this unit. The user can use this signal tied to an address decoder to enable the unit for a read/write operation.

"0" = Enable unit for I/O operations

"1" = DISABLE unit for I/O operations

C16Mhz 16 Mhz clock system clock.

DATA0-15	16 bit bidirectional data highway access to internal RAM and registers. When in 8 bit mode only DATA 0-7 are used. Data inputs / outputs are inverted when the Multibus interface is selected.
NACK	After a write / read cycle has begun, this signal indicates that the write / read operation to the unit has been acknowledged and that access has been granted. Read data is available and write data is complete. The user can complete the write / read cycle. "0" = Cycle is acknowledged, access granted. "1" = No acknowledge, wait.
NEMPTY	Empty flag for the Command / Status FIFO memory which can store up to 32 command words (RT) or 32 status words (BC). In RT mode the memory will store all command words that have accessed the main RAM. This includes all standard commands to receive and transmit data from the main RAM and mode codes with data that require subsystem involvement ie. Synchronize With Data and Transmit Vector Word. In BC mode all status responses are stored in this memory. Access to this memory is gained by reading from address 0 00 00. "0" output to this pin means the FIFO is empty (no words). "1" output to this pin means the FIFO is NOT empty (has words to be read).
NFULL	Full flag for the Command / Status FIFO memory. When the signal goes low the memory is full and will not store any more data.
NRES	Bidirectional reset pin. Interface to this pin should be in the form of an open collector pull down driver. The unit will be reset when a low level input is asserted on power up. The pin is bidirectional in that the unit will drive the signal out low after the status response of the mode code Reset Remote Terminal. Upon reset the unit will initialise to RT mode and will be able to respond immediately after the rising edge of NRES.
T0-15	16 bit bidirectional data highway access to internal RAM and registers. When in 8 bit mode only DATA 0-7 are used. Data inputs / outputs are inverted when the Multibus interface is selected. Allows the user to have access to the MIL-STD-1553 bus traffic in real time. The user can utilize this bus for message illegalization and read words such as Synch w/Data directly off the T0-15 bus. Utilizing NDATA signal, the user can read the data words off the T0-15 bus as the DMA burst is transferring the data into RAM.
UB	Upper byte: When the unit is in 8 bit mode this signal is used as the LSB of the address lines. In 16 bit mode the signal is not used and the LSB of the address lines is ADIN 0.
NRD	VME Mode Data Strobe for a data transfer 0 = Read/Write data 1 = Tri-state the Data 0-15 bus
Multibus Mode:	Read strobe for a data transfer 0 = Read data FROM the unit TO the Subsystem 1 = Tri-state the Data0-15 bus
NWR	VME Mode Read/Write direction flag for a NRD data strobe 0 = Write data FROM Subsystem TO the Device 1 = Read data FROM Device unit TO the Subsystem

Multibus Mode: Write strobe for a data transfer

0 = Write data FROM the Subsystem TO the Device

1 = Tri-state the Data0-15 bus

RT Status Word Discrete Inputs

The following signals are inputs to set the appropriate bits in the RT Status word. All inputs are sampled after the NVCR signal. These RT Status Word inputs should be latched by NVCR and remain stable until the next NVCR signal. All the inputs listed below are active low. To set any of the appropriate bits, the user must pull that input "low" ("0")

NME	Message Error, illegalizes message. Command will not be stored in Command / Status memory and no transfers to / from main RAM will take place. No data will be transmitted following the status.
NTF	Sets the Terminal Flag bit
NSR	Sets the Service Request bit
NBUSY	Sets the Subsystem Busy bit
NSSFLAG	Sets the Subsystem Flag bit
NDBCA	Sets the Dynamic Bus Control Accept bit in response to the Mode Code "Dynamic Bus Control Request"

RT Discrete Signals

BCST	Output high indicates command received was a broadcast. Signal will remain high until next command is received. "1" = Broadcast Command was received
MCDET	Output high indicates command received was a mode command. Signal will remain high until next command is received. "1" = Mode Code Command was received
NCMDSTRB	This signal indicates that a completely validated message has been received for standard subaddress data activity. Mode commands with or without data will not generate this signal. The NCMDSTRB signal is 8.5 uS long and is an indication that a DMA burst will initiate at the end of NCMDSTRB to transfer words between the 32 word data memory and the internal main RAM. All subsystem read / writes to the main RAM that have been acknowledged (NACK = "0") before NCMDSTRB has begun must now be completed within 8.5 uS. All subsystem read / write requests to the main RAM initiated after NCMDSTRB has begun will be held off (no acknowledge) until the DMA cycle has been completed. The length of the DMA cycle is dependant on the number of words to DMA into RAM. Access to the 32 word BTL memory is still possible during the DMA cycle by the subsystem. However, transfers between the BTL memory and the main RAM will be locked out.
NDBC	Active low indicates that the command received by the Remote Terminal was mode code Dynamic Bus Control. Signal will remain low until next command is received.

NSYNC	Signal to subsystem indicating receipt of a Synchronize mode commands. If the mode code has an associated data word, it will be available on T0-T15 at this time. If there is no associated data word, T0-T15 will be zero.
NVCR	Early indication that a Command Word has been received and is being processed. The Command Word received is available on the T0-15 bus for decoding at this time. The user can use this signal for message illegalization and to set the RT Status bits.
NDATA	Access to valid data word in real time before being written to RAM. Data word available on T0-T15 during active low signal.
NILLCMD	Input to illegalise a command to the Remote Terminal with a clear status response. The signal is sampled after NVCR except non mode code receive commands in which case it is sampled after the last data word has been received. A low on this input will illegalise the message, Command will not be stored in the Command / Status memory and no transfers to / from main RAM will take place. The device will respond with a clear status unless a bit has been specifically set. No data will be transmitted following status.

BC Discrete Signals

NNEWBUS	A Bus Control sequence may not normally be initiated until the current sequence is completed, indicated by signal EOT. However, the Bus Control sequence may be terminated and restarted if NNEWBUS is active low along with write to address 0 00 00 (000h). This feature would only be used in bus switching.
EOT	Indicates that a valid transfer has been completed on the bus selected. 1 = Valid transfer completed 0 = Not yet Completed
ERROR	Indication that an error has occurred either in the information transferred to the unit from the subsystem or in the transfers on the 1553 data bus. Nature of error is available by reading from register location 0 00 12 (012h). 1 = Error has occurred 0 = No error
NSTSTRB	This signal goes low for 8.5 uS to indicate a valid transfer has been completed on the 1553 data bus and the received Status word is now available on the T0-T15 highway. The Status word is also stored in the Command / Status memory at this time. Once the signal goes high data received by the Bus Controller (RT to BC transfer) will be transferred to the main RAM from the 32 word data buffer memory. Note: Data transferred in RT to RT transfers is not stored in the Bus Controllers main RAM.
NNINHST	May be used to illegalise a message just received. Signal can be tied to STATUS for illegalisation due to 1760 checksum failures. A low will prevent any data received being transferred to the main RAM, and the Status word will not be stored in the Command / Status memory.

Remote Terminal (RT) Mode

SEQUENCE OF OPERATION

The following section describes the sequence of operation for the various commands that are received by the Smart unit in RT Mode.

RECEIVE COMMAND

An incoming command word is verified for all protocol checks (such as parity and bit count). The verified command word is placed on the T0-15 bus and the NVCR signal is strobed. It is at this time that a message can be illegalized.

Each successive data word after the command word is placed in an internal buffer FIFO. This is done to double buffer the incoming data for complete message verification. Only after the message is completely validated will the data be transferred to the internal RAM. Otherwise, the contents of the FIFO is automatically flushed. **This ensures that only valid data will ever be read by the subsystem.** The transfer from the FIFO to the RAM is accomplished by a fast DMA burst. The guarantee of only valid data in RAM greatly simplifies a MIL-STD-1553 RT implementation. Error handling of data is not required by the subsystem.

The subsystem is allowed the most flexibility to access the RAM without contending with 1553 bus traffic. In 1553, data words are received at a rate of 20 μ Sec per word or a maximum time of 640 μ Sec for a 32 word transfer. Many other systems do not buffer the incoming data at all. That means that the RAM is periodically being updated with data words into the RAM for up to 640 μ Seconds. If an error occurs, the corrupt data is already in memory and must be sorted out by the subsystem microprocessor. The Smart unit buffers the data so that the RAM is completely available to the subsystem until the DMA transfer to RAM occurs. The possibilities of memory contention is greatly reduced and the contents of RAM is guaranteed to be valid.

When the entire set of received data words are transferred to the buffer FIFO, the NCMDSTRB goes low indicating that a completely validated message has been received. The received Command Word again appears on the T0-15 bus at this time. The end of the NCMDSTRB strobe will initiate the DMA cycle to transfer the data words from the buffer FIFO to internal RAM. The NCMDSTRB pulse is 8.5 μ Sec long and during this time interval, the bus arbitration logic is active. If the subsystem has already begun a read/write operation before NCMDSTRB, the NACK (acknowledge) signal will go low for 500 nSec allowing the completion of the read/write command. The read/write operation must be completed within the remaining 8 μ Sec. If a read/write operation starts after the NCMDSTRB strobe has begun, the NACK will not occur and thus hold off the subsystem for the duration of the DMA cycle to internal RAM.

During NCMDSTRB, the Command Word is loaded into the Command/Status FIFO stack and the NEMPTY line goes high. The user can utilize this signal as an indication that some activity has occurred. The Command/Status FIFO stores up to 32 command words for the subsystem to review. This allows the processor to only response to the 1553 unit when something has occurred. Constant polling of the 1553 unit is not required. To reduce

processor intervention even further, the Command/Status FIFO will only store commands that have associated data with it.

MESSAGE ILLEGALIZATION

Any message can be illegalized by applying an active low on the NME signal within 600 nSec of the rising edge of NVCR at this time. If NME signal is pulled low, the RT will respond with a Status word having the Message Error bit set.

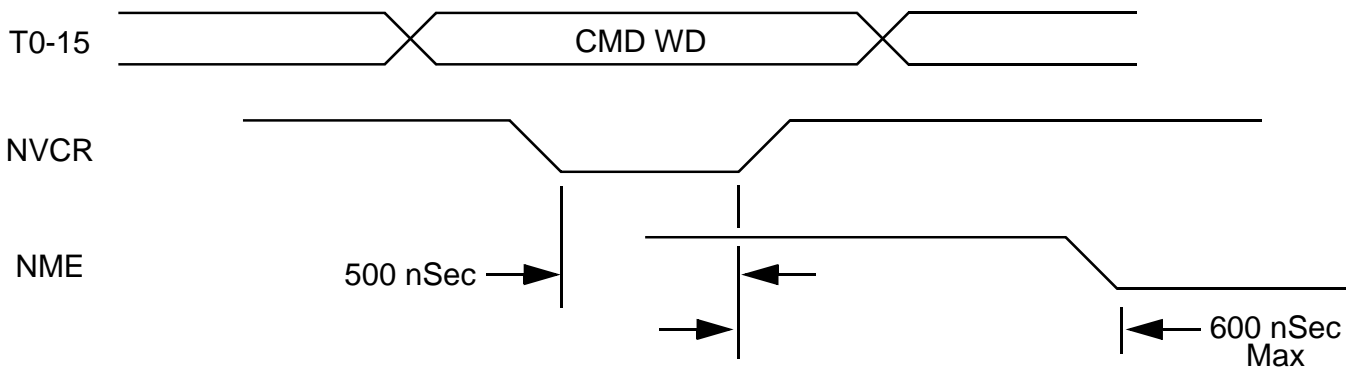

One way to implement this function is to place a latching PROM to the T0-T10 data bus. The PROM would only have to decode 11 bits (5 bits subaddress, 5 bits word count, 1 bit T/R) and have a one bit output to place a high/low level on the NME input pin. The upper five bits (T11-T15) are just the Remote Terminal address for the unit which is a constant so no decode of these bits are necessary. The latching signal for the PROM would be the NVCR line. The NME pin will be read and acted upon 600 nSec after the rising edge of NVCR. The NME signal would remain latched and stable until the next rising edge of NVCR.

MIL-STD-1760 FEATURES

To enable the 1760 features checksum validation, the NENCHK line is held low. This enables the integrated on-chip hardware checksum features. The hardware automatically checks the incoming message for the correct checksum.

1760 HEADER WORD

The signal NHDR will be an early indicator of the 1760 header word. This headerword will appear on the T0-15 bus when the NHDR signal is low. The NHDR signal will go low on every header word (first data word) even if the 1760 checksum circuitry is enabled or not. NHDR is just an indicator of the first data word on the bus T0-15.

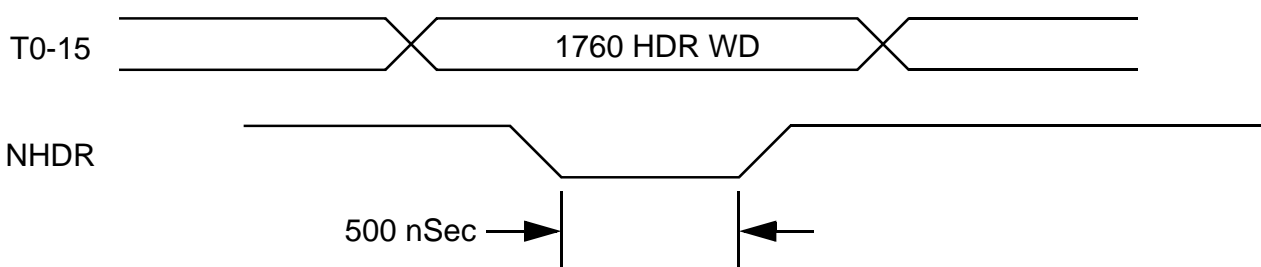

SIGNALS THAT INDICATE CHECKSUM FAILURE

For 1760 applications, the STATUS line indicates if a message has failed checksum. The STATUS line will toggle up or down for each received data word as it is calculating the checksum and is sampled on the falling edge of NCMDSTRB. The STATUS line can be tied to any of the Status Word Bit inputs to set those bits in the event of a checksum fail. STATUS is an open output line that will set the selected Status Word Bits for the Status Word response in the current message. This is one of the great features for this product. The subsystem does not have to verify the checksum in software to detect the error. The SmART unit automatically does this in hardware and the unit is able to flag the error and set the a Status Word Bit on the CURRENT Status Word response. This minimizes processor overhead and reduces response time in notifying the Bus Controller that an error has occurred.

For 1760 applications, the NVALCHK signal also indicates a valid checksum for the Receive Command message. NVALCHK is a latched version of the STATUS signal and is updated only on Receive Commands. It is valid on the falling edge of NCMDSTRB of a Receive Command and remains stable until the next Receive Command message. A Transmit Command message will not alter this signal because a Transmit Command does not require an incoming checksum validation.

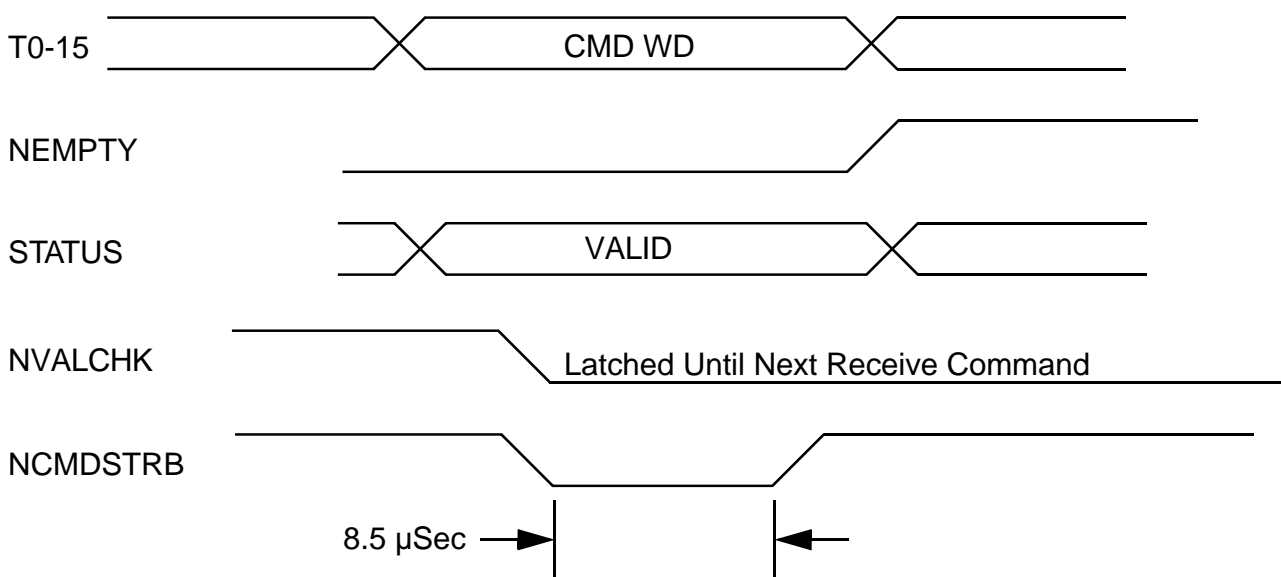

BLOCK TRANSFER LOGIC

The Block Transfer Logic (BTL) may be enabled for both Remote Terminal and Bus Controller.

The BTL consists of a 32 word memory buffering the subsystem to the main RAM thus guaranteeing data consistency for both transmit and receive transfers.

All reads and writes to the BTL are identical to read / write to the main RAM. The address locations are the same. The only difference is that the BTL circuitry will intercept those read

/ writes and store them in the buffer instead. The user accesses the same locations as if they would if they were directly accessing the main RAM.

The block transfer logic is enabled with signal NENBTL (pin A7) being active low and is not applicable to subaddress 00 and 1F (unless McAir is selected) areas of ram. The block transfer logic may also be configured by writing to certain address locations providing NENBTL is selected, ie.

0 1 00 02	402h	Disable Read	Disable Write
0 1 00 03	403h	Disable Read	Enable Write
0 1 00 04	404h	Enable Read	Disable Write
0 1 00 05	405h	Enable Read	Enable Write

Reset will enable both Write and Read.

Note: All 257X versions with internal RAM that do not have NENBTL as a discrete input have it enabled internally.

READ (RECEIVE)

The Read BTL functions similarly to the Write BTL in that the BTL buffers the read activity. A subsystem read will initially generate a DMA of that entire portion of the subaddress to be stored in the BTL buffer. The subsystem can then read out the data at its leisure while the main RAM is free for future updates. Since the entire portion of the subaddress data was DMA from the RAM, the data read from the BTL buffer is guaranteed contiguous.

The user must read data from the device in a specific sequence starting with the first word received in the n-1 location and ending with the last word received in location 00 of the subaddress. The BTL will sense the read from location 00 and reset the sequence ready for a new access.

1. The first word of a received message will be read first, this will initiate a burst DMA transfer of a complete message from main memory to the 32 word BTL buffer memory, during which time the subsystem will be locked out. Data is transferred at the rate of 250 ns per word.
2. The sub system can then read data from the ram at its leisure. The last word to be read will be the last word received in the message and read from location zero. This will reset the block transfer logic.
3. If the 1553 DMA transfer to the main RAM becomes active during the burst transfer, the transfer will complete and then be locked out until the 1553 is complete. However the 32 word BTL buffer memory will be accessible to the subsystem at this time to read out the data.
4. If the 1553 DMA transfer to the main RAM becomes active before the start of the burst transfer, the transfer will be locked out until the 1553 is complete. The sub system will be locked out during this time (main ram being accessed by the 1553 and the 32 word buffer memory is waiting for the receive message). When the 1553 is complete the burst transfer will take place and then unlock the subsystem.

5. Once the burst transfer has commenced it will complete, thus ensuring data consistency.

DMA TRANSFER TIMES

The DMA cycle transfers words from the FIFO to internal RAM at a rate of one word each 1 μ Sec. The maximum DMA cycle time could possibly occur for a 32 data word transfer if the RAM is accessed at the beginning of NCMDSTRB Strobe. Maximum subsystem hold-off time would be 8.5 μ Sec (NCMDSTRB Signal) + 32 μ Sec (0.5 μ Sec per word) for a total of 24.5 μ Sec.

TRANSMIT COMMAND

The incoming command word is verified for all protocol checks (such as parity and bit count). The verified command word is placed on the T0-15 bus and the NVCR signal is strobed. It is at this time that a message can be illegalized.

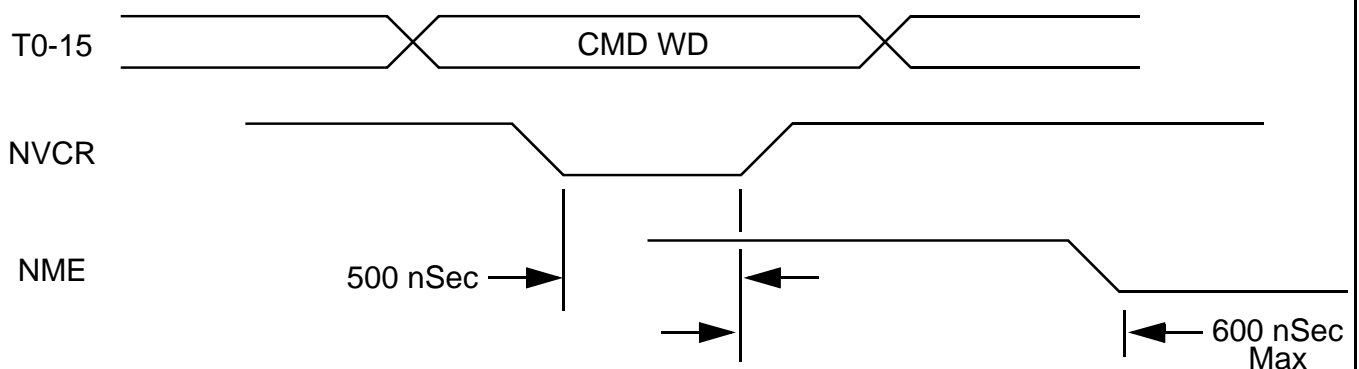

Any message can be illegalized by applying an active low on the NME signal within 600 nSec of the rising edge of NVCR at this time. The RT will respond with a Status word having the Message Error bit set. See Section 1.2.1.1 for implementing the Message Illegalization.

The NCMDSTRB goes low indicating that a completely validated message has been received. The validated Command Word again appears on the T0-15 bus at this time. The end of the NCMDSTRB strobe will initiate the DMA cycle to transfer the data words from internal RAM to the buffer FIFO.

Buffering the outgoing message with a FIFO means that the subsystem is allowed the most flexibility to access the RAM without contending with 1553 bus traffic. In 1553, data words are transmitted at a rate of 20 μ Sec per word or a maximum time of 640 μ Sec for a 32 word transfer. Many other systems do not buffer the outgoing data at all. That means that the RAM is periodically being accessed for data words from the RAM for up to 640 μ Seconds. The SmART unit buffers the outgoing data so that the RAM is completely available to the subsystem after the DMA transfer from RAM occurs. The possibilities of memory contention is greatly reduced and the contents of the outgoing data will not be affected by subsystem operations.

The NCMDSTRB pulse is 8.5 μ Sec long and during this time interval, the bus arbitration logic is active. If the subsystem has already begun a read/write operation before NCMDSTRB, the NACK (acknowledge) signal will go low for 500 nSec allowing the

completion of the read/write command. The read/write operation must be completed within the remaining 8 μ Sec. If a read/write operation starts after the NCMDSTRB strobe has begun, the NACK will not occur and thus hold off the subsystem for the duration of the DMA cycle from internal RAM.

During NCMDSTRB, the Command Word is loaded into the Command/Status FIFO stack and the NEMPTY line goes high. The user can utilize this signal as an indication that some activity has occurred. The Command/Status FIFO stores up to 32 command words for the subsystem to review. This allows the processor to only response to the 1553 unit when something has occurred. Constant polling of the 1553 unit is not required. To reduce processor intervention even further, the Command/Status FIFO will only store commands that have associated data with it.

MIL-STD-1760 FEATURES

If the 1760 features are enabled (NENCHK line is held low), the checksum word is automatically generated and transmitted as the last data word. The subsystem processor does not have to calculate or load the checksum word into RAM. The SmArT unit automatically does this in hardware and transmits the correct checksum data word as the last word out. This reduces subsystem processor overhead significantly.

SIGNALS THAT INDICATE CHECKSUM FAILURE

For 1760 applications, the STATUS line indicates if a message has failed checksum. The STATUS line will stay high for a Transmit Command word because there is no associated data words received for checksum validation. STATUS is sampled on the falling edge of NCMDSTRB. The STATUS line can be tied to any of the Status Word Bit inputs to set those bits in the event of a checksum fail. STATUS is an open output line that will set the selected Status Word Bits for the Status Word response in the current message. This is one of the great features for this product. The subsystem does not have to verify the checksum in software to detect the error. The SmArT unit automatically does this in hardware and the unit is able to flag the error and set the a Status Word Bit on the CURRENT Status Word response. This minimizes processor overhead and reduces response time in notifying the Bus Controller that an error has occurred.

For 1760 applications, the NVALCHK signal does not change from it's previous state since a Transmit Command Word has no incoming data words. NVALCHK is a latched version of the STATUS signal and is updated only on Receive Commands. It is valid on the falling edge of NCMDSTRB of a Receive Command and remains stable until the next Receive Command message. A Transmit Command message will not alter this signal because a Transmit Command does not require an incoming checksum validation.

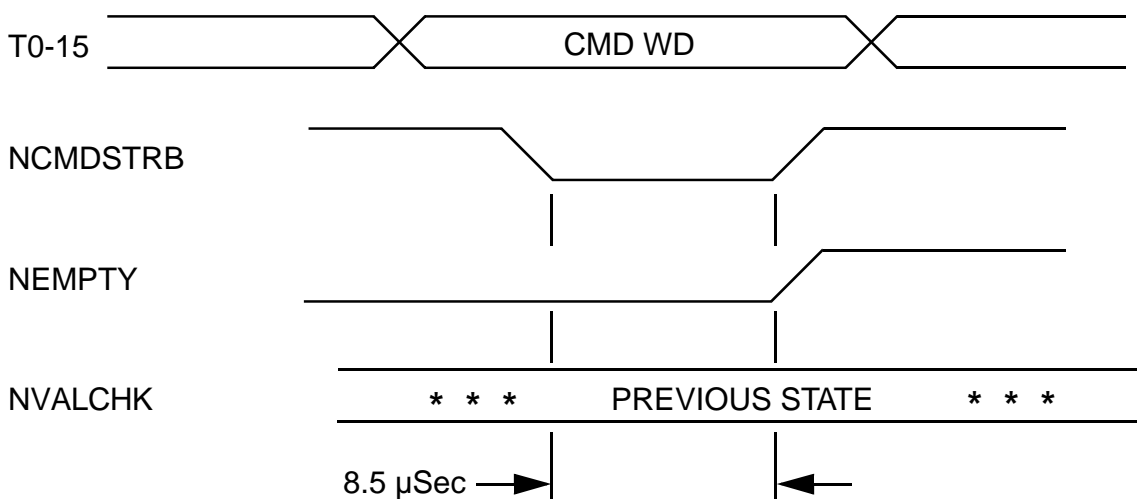

BLOCK TRANSFER LOGIC / DMA TRANSFER TIMES

All reads and writes to the BTL are identical to read / write to the main RAM. The address locations are the same. The only difference is that the BTL circuitry will intercept those read / writes and store them in the buffer instead. The user accesses the same locations as if they would if they were directly accessing the main RAM.

The block transfer logic may also be configured by writing to certain address locations providing NENBTL is selected, ie.

0 1 00 02	402h	Disable Read	Disable Write
0 1 00 03	403h	Disable Read	Enable Write
0 1 00 04	404h	Enable Read	Disable Write
0 1 00 05	405h	Enable Read	Enable Write

Reset will enable both Write and Read.

WRITE

The Write BTL Logic basically stores all writes to a particular subaddress in the buffer until the subsystem has completed the entire subaddress update. When the subsystem has finished, the BTL will generate a burst DMA from the BTL to main RAM in one contiguous transfer. This guarantees that the entire subaddress is updated. Until the DMA transfer the BTL buffer allows the main RAM to be free for updates from the 1553 data bus.

The user must write data to the device in a specific sequence starting with the first word for transmission in the n-1 location and ending with the last word for transmission in location 00 of the subaddress. The BTL will sense the write to location 00 and initiate the DMA sequence.

1. Data for one message is written to the 32 word buffer memory at any speed by the subsystem. The first word for transmission is written first to the n-1 location and the last word for transmission is written last to the 00 location of the subaddress.
2. The address of the first word is stored in a register / counter within the "block transfer logic".
3. The last word for transmission is always written to location zero, this will trigger the transfer of data from the 32 word buffer memory to the main memory. Data is transferred at the rate of 250 nS per word. A full 32 word transfer will take approximately 8 uS.
4. If the 1553 is quiet the entire message will immediately be transferred in a single burst to the main memory, the address being generated by the counter within the block transfer logic. During this transfer the subsystem will be locked out via NACK from any new updates.
5. If the 1553 DMA transfer to the main RAM becomes active during the burst transfer, the transfer will complete and then be locked out of any new updates until the 1553 is complete. However the BTL buffer memory will be accessible to the subsystem at this time.
6. If the 1553 DMA transfer to the main RAM becomes active before the start of the burst transfer, the transfer will be locked out (after location zero is written to) until the 1553 is complete. The sub system will be locked out during this time (main ram being accessed

by the 1553 and the BTL buffer memory is full). If the BTL memory is not fully loaded, the subsystem can continue to load the BTL memory until full (write to 00 indicates a full condition). When the 1553 is complete the burst transfer will take place and then unlock the subsystem.

7. Once the burst transfer has commenced it will complete, thus ensuring data consistency.

The DMA cycle begins after the rising edge of NCMDSTRB. All requested data words are placed in an internal buffer FIFO. This is done to double buffer the outgoing data as a contiguous block and free up the internal RAM as quickly as possible. The DMA cycle transfers words from internal RAM at a rate of one word each 1 μ Sec. The maximum DMA cycle time would occur for a 32 data word transfer or 32 μ Sec. Maximum subsystem hold-off time would be 8.5 μ Sec + 32 μ Sec for a total of 40.5 μ Sec.

CHANGING THE STATUS WORD BITS

There are four Status word bits that can be altered by the subsystem through simple write operations. These four bits and addresses are as follows:

SERVREQ	0 0 00 08	008h
BUSY	0 0 00 04	004h
SSFLAG	0 0 00 02	002h
DBCA	0 0 00 01	001h

See Memory Map for further details.

DEVICE STATUS

The status of the device may be determined by reading from location 0 00 01, the status bits and BTL status will be available on DATA pins 0-7.

DATA0	DBCA
DATA1	SSFLAG
DATA2	SSBUSY
DATA3	SERVREQ
DATA4	BTL WRITE ENABLED
DATA5	BTL READ ENABLED
DATA6	OFF-LINE SELF TEST ENABLED
DATA7	ON-LINE SELF TEST ENABLED

See Memory Map for further details.

BIT REGISTER

With MCAIR (pin F1) disabled, writing data to 0 1 00 13 or 0 1 1F 13 will set the content of the BIT register. The data may also be read from these locations. This register is **non-resettable**. See Memory Map for further details.

DATA STORAGE AND RETRIEVAL IN RAM

The storage and retrieval of data on RAM is optimized for fast processor accesses. The data (Transmit or Receive) is stored with the first data word (Word #0) in memory location #0n and the last data word (Word #n) in location 00. The processor reads the Command word and extracts the T/R bit, subaddress, and word count bits as a pointer to the proper memory location. The word count field is used as a down counter variable so that a Do Loop routine is executed and then branched out at counter = 00. This may be more efficient in some compilers than an up counter and comparing current loop counter with word count field on every loop. The following section contains sample software pseudo code for data handling. See Memory Map for further details.

SAMPLE SOFTWARE CODE

The following section contains sample pseudo-code for programming and operation the SmaRT unit. The code most resembles Microsoft Quick Basic code (IBM DOS compatible) for simplicity.

RETRIEVING OR LOADING DATA TO RAM

```
REM *****
REM *
REM *   Routines for operation in Remote Terminal (RT) Mode
REM *
REM *****
REM *****
REM *   Variables
REM *   _____
REM *
REM *   NCMDEEMPTY   0 = EMPTY (NO Command WORDS IN FIFO)
REM *                1 = HAVE COMMAND WORDS IN FIFO
REM *
REM *                This signal is derived from NEMPTY
REM *                on the CT2577.
REM *
REM *   MODE          0 = RT MODE
REM *                1 = BC MODE
REM *
REM *   CMDWORD = COMMAND WORD READ FROM FIFO
REM *
REM *   WORDCNT = LOWER 5 BIT OF COMMAND WORD
REM *             INDICATES HOW MANY DATA WORDS
REM *
REM *   DATA() = DATA ARRAY (32 WORDS MAX)
REM *
REM *   MEMPOINT = LOWER 11 BITS OF THE COMMAND WORD
REM *
REM *   T/R_BIT = BIT #10 OF THE COMMAND WORD
REM *
REM *
```



```

REM *
REM *
REM *****
REM*****
REM *****  INITIALIZATION ROUTINE
*****
REM *****

INIT:  DEFINT A-Z

      OUT 1, 400(h) "WRITE TO THIS ADDRESS TO SET CT2577 INTO RT MODE

      INPUT MODE, XX(h) "READ PIN BCRNT FROM THE CT2577
              "      0 = RT MODE
              "      1 = BC MODE

      DIM DATA(32)      "LOCATIONS 1-32 = 32 WORDS

      REM *****
      REM *****
      REM *****  DETECT COMMAND ROUTINE *****
      REM *****

DETECT: IF NCMDEEMPTY = 1 THEN
          CMDWORD = INPUT(OOh) ;READ FROM LOCATION 00
          MEMPOINT = CMDWORD & 0000011111111111(b)
          T/R_BIT = CMDWORD & 0000010000000000(b)
          WORDCNT = CMDWORD & 0000000000011111(b)

              MEMPOINT = MEMPOINT - 1

              "OFFSET POINTER SO THAT FINAL POSITION
              "IS AT LOCATION 00. FOR EXAMPLE, A ONE
              "WORD TRANSFER SHOULD BE LOADED IN
              "LOCATION 00 OF THAT SUBADDRESS.

      END IF

      IF WORDCNT = 00000(b) THEN
      WORDCNT = 32 "ALL ZEROS IN WORD COUNT FIELD = 32 DATA WORDS
      END IF

      IF T/R_BIT = 0000000000000000(b) THEN
          REDIM DATA() ;CLEARS ARRAY DATA()
              ; GOT TO ROUTINE TO READ OUT
              ; THE RECEIVED DATA FROM THE 1553 BUS
          GOTO RECEIVE
      END IF

      IF T/R_BIT = 0000010000000000(b) THEN
          REDIM DATA() ;CLEARS ARRAY DATA()
          FOR J = 1 TO 32

```

```

        DATA(J) = XXXX ;LOAD IN DATA FOR TRANSMIT
    NEXT J
    GOTO TRANSMIT
END IF
GOTO END

```

```

REM *****
REM *** ROUTINE TO LOAD DATA INTO RAM FROM PROCESSOR *****
REM *****

```

```

TRANSMIT:  FOR I = 1 TO WORDCNT
            OUTPUT DATA(I), MEMPOINT ; WRITES DATA() INTO LOCATION
                                           ; MEMPOINT
            MEMPOINT = MEMPOINT - 1
        NEXT I

        GOTO END

```

```

REM
*****
REM *** ROUTINE TO READ DATA FROM RAM TO PROCESSOR
*****
REM
*****

```

```

RECEIVE:  FOR I = 1 TO WORDCNT
            DATA(I) = INPUT(MEMPOINT) ; READS LOCATION MEMPOINT INTO
                                           ; DATA() ARRAY
            MEMPOINT = MEMPOINT - 1
        NEXT I
        GOTO END

```

```

REM
*****
REM *** ROUTINE TO SCAN FOR MORE MESSAGES
*****
REM
*****

```

```

END:  IF NCMDEEMPTY = 1 THEN
        GOTO DETECT
    ELSE
        RETURN

        ; GO OFF AND DO SOMETHING ELSE
        ; UNTIL ANOTHER 1553 MESSAGE IS RECEIVED

    END IF

```

SELF TEST

The self test feature is an internal and external loop back test for additional verification of functionality. This is in addition to the Remote Terminal Wraparound circuitry. The difference is that this test is manual and under subsystem control. The subsystem microprocessor initiates the self test and the subsequent data word pattern. The subsystem then reads back the wrapped data word and determines if it is correct. The online self test must be done with the 1553 data bus quiet.

The self test function is enabled or disabled by writing to certain address locations. Reset will disable self test.

0 1 00 06	Enable offline self test and set device status bit 6
0 1 00 07	Enable online self test and set device status bit 7
0 1 00 08	Disable self test

When self test is enabled the device is set up as both BC and RT. When self test is disabled the device will revert back to its previous state.

BASIC OPERATION

The basic operation is for the BC to transmit the message "receive one data word" and for the RT to receive this message.

If the online self test is selected the message will be transmitted onto the 1553 bus via the transceivers and be received by the RT via transceivers. The RT will not respond with Status.

If the offline self test is selected the transceivers will be inhibited and the Manchester encoder output is routed to the Manchester decoder input.

The status of the device may be obtained by reading from 0 0 00 01. Bit 6 is offline self test enabled. Bit 7 is online self test enabled.

DETAILED OPERATION

1. Enable self test by writing to either 1 00 06 (offline) or 0 1 00 07 (online).
2. Select required 1553 data bus to be tested by writing to 0 0 00 10 or 0 0 00 18.
3. Write the data word contents required for the self test to the appropriate RAM location ie. For broadcast message: 2(bcast) 01-1E(subaddress) 00(1 word) or normal receive message: 0(rec) 01-1E(subaddress) 00(1 word).
4. Initiate BC to RT transfer of one data word by writing to address 0 00 00 with a data word content of 1F or RTAddr 0(rec) 01-1E(subaddress) 01(1 data word). The following automatic sequence is now initiated:
 - a) The Command word (data word written to location 0 0 00 00) is processed by the BC protocol, transferred to the Manchester encoder and transmitted onto the bus (online self test) or to the Manchester decoder (offline self test).

- b) The self test data word is read from the appropriate RAM location, transferred to the encoder and transmitted contiguously following the command word.
 - c) The Command word is received by the Manchester decoder, if valid and with correct RT address or broadcast is stored in the RT protocol.
 - d) The data word is received by the decoder and if valid is stored in the 32 word data memory.
 - e) The RT protocol will validate the message and if successful will write the Command word to the 32 word Command / Status memory and transfer the data word to the appropriate RAM location.
5. As the data word received is written to the same RAM location that it was originally accessed from, the contents should be altered while the self test is in progress (eg. write 0000). This can be done immediately after the BC to RT transfer was initiated. There is approx 45 us for the self test to complete.
 6. To ensure that the RAM contents have been altered it is advisable to read the data back from the RAM.
 7. On completion of a successful self test the signal NCMDSTRB will go active low, after which the data can be read from the RAM and compared with the data used in the self test.
 8. In addition the Command word used in the self test may be read from 0 00 00.
 9. Disable self test by writing to 1 00 08. The device will revert back to its original state (BC or RT).

SUMMARY OF OPERATION

Device can be either RT or BC.

- | | |
|--|---|
| 1. ADDR = 1 00 06 (Write)
OR
ADDR = 1 00 07 (Write) | Select offline self test.
Select online self test. |
| 2. ADDR = 1 00 10 (Write)
OR
ADDR = 1 00 18 (Write) | Select bus 0.
Select bus 1. |
| 3. ADDR = 2 01-1E 00 (Write) DATA = n
OR
ADDR = 0 01-1E 00 (Write) DATA = n | Write self test data to BCAST location.
Write self test data to RECEIVE location. |
| 4. ADDR = 0 00 00 (Write) DATA = 1F 0 01-1E 01
OR
ADDR = 0 00 00 (Write) DATA = RTAD 0 01-1E 01 | Transmit message (Bcast receive 1 word).
Transmit message (Receive 1 word). |
| 5. ADDR = 2 01-1E 00 (Write) DATA = 0
OR
ADDR = 0 01-1E 00 (Write) DATA = 0 | Write 0 to self test location.
Write 0 to self test location. |
| 6. ADDR = 2 01-1E 00 (Read) DATA = 0
OR
ADDR = 0 01-1E 00 (Read) DATA = 0 | Read 0 from self test location.
Read 0 from self test location. |
| 7. ADDR = 2 01-1E 00 (Read) DATA = n
OR
ADDR = 0 01-1E 00 (Read) DATA = n | Read self test data after NCMDSTRB.
Read self test data after NCMDSTRB. |
| 8. ADDR = 0 00 00 (Read) DATA = 1F 0 01-1E 01
OR
or ADDR = 0 00 00 (Read) DATA = RTAD 0 01-1E 01 | Read command from command memory.
Read command from command memory. |
| 9. ADDR = 1 00 08 (Write)
ADDR = 0 00 01 (Read) | Disable self test.
Read device status:
Bit 6 = Offline self test.
Bit 7 = Online self test |

CT2577 /79 RT/BC Device Memory Map Breakdown

The following description is for devices that have internal 3K memory.
 ALL '**User**' Locations are Read/Writable

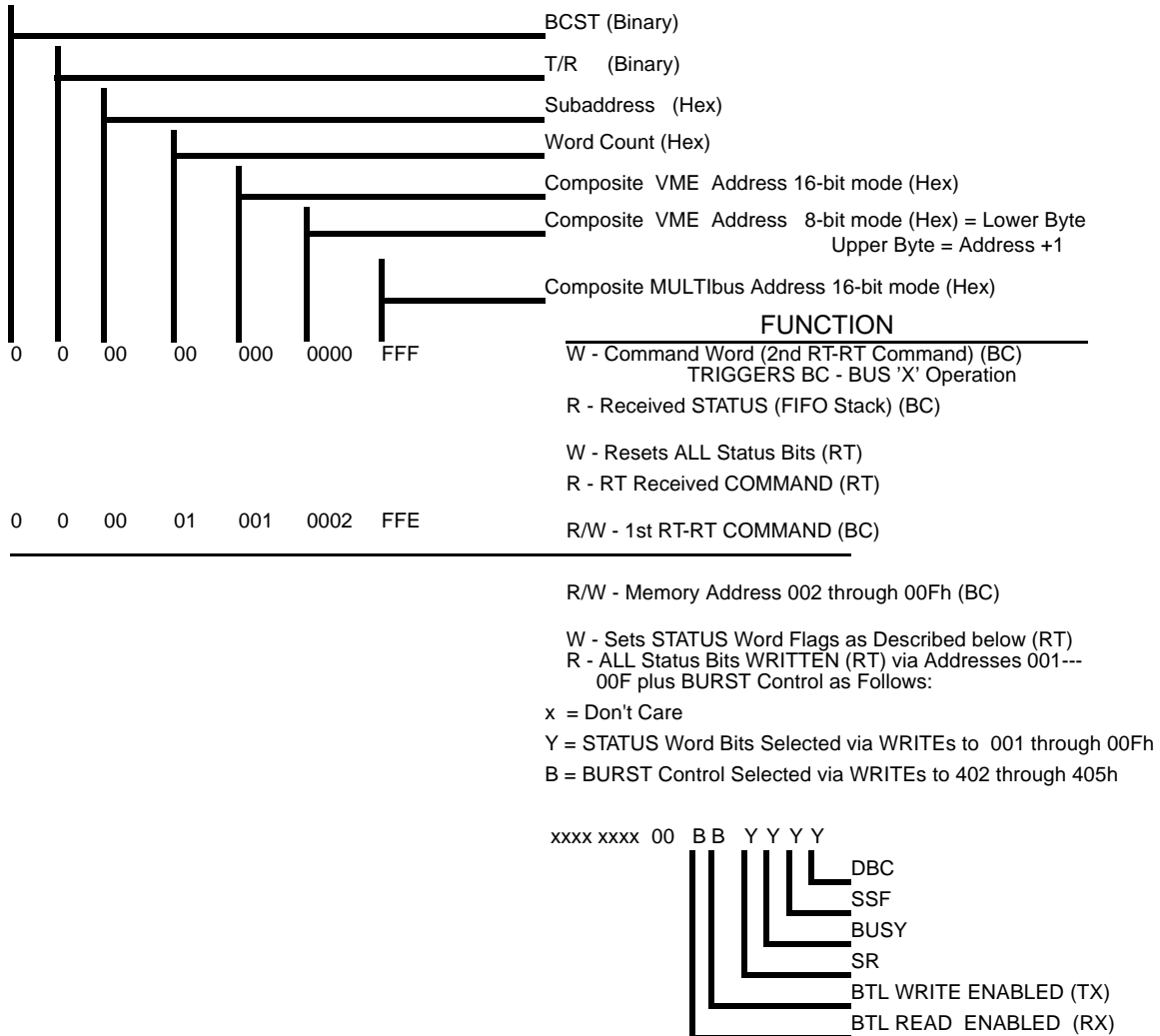

RT/BC Device Memory Map Code Breakdown Descriptions

RT STATUS WORD Control Sets

0 0 00 01	001	0002	FFFE	DBC
0 0 00 02	002	0004	FFFD	SSFLAG
0 0 00 03	003	0006	FFFC	SSFLAG + DBC
0 0 00 04	004	0008	FFFB	BUSY
0 0 00 05	005	000A	FFFA	BUSY + DBC
0 0 00 06	006	000C	FFF9	BUSY + SSFLAG
0 0 00 07	007	000E	FFF8	BUSY + SSFLAG + DBC
0 0 00 08	008	0010	FFF7	SERVREQ
0 0 00 09	009	0012	FFF6	SERVREQ + DBC
0 0 00 0A	00A	0014	FFF5	SERVREQ + SSFLAG
0 0 00 0B	00B	0016	FFF4	SERVREQ + SSFLAG + DBC
0 0 00 0C	00C	0018	FFF3	SERVREQ + BUSY
0 0 00 0D	00D	001A	FFF2	SERVREQ + BUSY + DBC
0 0 00 0E	00E	001C	FFF1	SERVREQ + BUSY + SSFLAG
0 0 00 0F	00F	001E	FFF0	SERVREQ + BUSY + SSFLAG + DBC

BC Control Area

0 0 00 10	010	0020	FFEF	BC - SELECT BUS 0
	(18	018	0040	FFE7BC - SELECT BUS 1)

RT/RX BC/TX Mode Area 00 - SA 00 (0) and BC Control

0 0 00 11	011	0022	FFEE	SYNC WORD	
0 0 00 12	012	0024	FFED	ERROR Register	
0 0 00 13	013	0026	FFEC	User	
0 0 00 14	014	0028	FFEB	SELECTED TX SHUTDOWN (0000/0001)	
0 0 00 15	015	002A	FFEA	OVERRIDE SELECTED TX SHUTDOWN (0000/0001)	
0 0 00 16	016	002C	FFE9	User	
0 0 00 17	017	002E	FFE8	User	
0 0 00 18	018	0030	FFE7	BC - SELECT BUS 1	
	(10	010	0020	FFEF	BC - SELECT BUS 0)
0 0 00 19	019	0032	FFE6	User	
THROUGH					
0 0 00 1F	01F	003E	FFE0	User	

30 RT Receive / BC Transmit Subaddresses - SA 01-1E (1-30)

0 0 01 00	020	0040	FFDF	SA1Last Word (Word 01 if WC =1)
0 0 01 04	024	0048	FFDB	Word 01 if WC = 5
0 0 01 1F	03F	007E	FFC0	Word 01 if WC = 32
0 0 02 00	040	0080	FFBF	SA2
0 0 02 1F	05F	00BE	FFA0	
0 0 03 00	060	00C0	FF9F	SA3

0 0 03 1F	07F	00FE	FF80	
0 0 04 00	080	0100	FF7F	SA4
0 0 04 1F	09F	013E	FF60	
0 0 05 00	0A0	0140	FF5F	SA5
0 0 05 1F	0BF	017E	FF40	
0 0 06 00	0C0	0180	FF3F	SA6
0 0 06 1F	0DF	01BE	FF20	
0 0 07 00	0E0	01C0	FF1F	SA7
0 0 07 1F	0FF	01FE	FF10	
0 0 08 00	100	0200	FEFF	SA8
0 0 08 1F	11F	023E	FEE0	
0 0 09 00	120	0240	FEDF	SA9
0 0 09 1F	13F	027E	FEC0	
0 0 0A 00	140	0280	FEBF	SA10
0 0 0A 1F	15F	02BE	FEA0	
0 0 0B 00	160	02C0	FE9F	SA11
0 0 0B 1F	17F	02FE	FE80	
0 0 0C 00	180	0300	FE7F	SA12
0 0 0C 1F	19F	033E	FE60	
0 0 0D 00	1A0	0340	FE5F	SA13
0 0 0D 1F	1BF	037E	FE40	
0 0 0E 00	1C0	0380	FE3F	SA14
0 0 0E 1F	1DF	03BE	FE20	
0 0 0F 00	1E0	03C0	FE1F	SA15
0 0 0F 1F	1FF	03FE	FE00	
0 0 10 00	200	0400	FDFE	SA16
0 0 10 1F	21F	043E	FDE0	
0 0 11 00	220	0440	FDDF	SA17
0 0 11 00	23F	047E	FDC0	
0 0 12 00	240	0480	FDBF	SA18
0 0 12 1F	25F	04BE	FDA0	
0 0 13 00	260	04C0	FD9F	SA19
0 0 13 1F	27F	04FE	FD80	
0 0 14 00	280	0500	FD7F	SA20
0 0 14 1F	29F	053E	FD60	
0 0 15 00	2A0	0540	FD5F	SA21
0 0 15 1F	2BF	057E	FD40	
0 0 16 00	2C0	0580	FD3F	SA22
0 0 16 1F	2DF	05BE	FD20	
0 0 17 00	2E0	05C0	FD1F	SA23
0 0 17 1F	2FF	05FE	FD00	
0 0 18 00	300	0600	FCFF	SA24
0 0 18 1F	31F	063E	FCE0	
0 0 19 00	320	0640	FCDF	SA25
0 0 19 1F	33F	067E	FCC0	
0 0 1A 00	340	0680	FCBF	SA26
0 0 1A 1F	35F	06BE	FCA0	
0 0 1B 00	360	06C0	FC9F	SA27
0 0 1B 1F	37F	06FE	FC80	

0 0 1C 00	380	0700	FC7F	SA28
0 0 1C 1F	39F	073E	FC60	
0 0 1D 00	3A0	0740	FC5F	SA29
0 0 1D 1F	3BF	077E	FC40	
0 0 1E 00	3C0	0780	FC3F	SA30
0 0 1E 1F	3DF	07BE	FC20	

RT/RX BC/TX Mode Area - SA 1F (31)

0 0 1F 00	3E0	07C0	FC1F	User
THROUGH				
0 0 1F 10	3F0	07E0	FC0F	User
0 0 1F 11	3F1	07E2	FC0E	SYNC WORD
0 0 1F 12	3F2	07E4	FC0D	User
0 0 1F 13	3F3	07E6	FC0C	User
0 0 1F 14	3F4	07E8	FC0B	SELECTED TX SHUTDOWN (0000/0001)
0 0 1F 15	3F5	07EA	FC0A	OVERRIDE SELECTED TX SHUTDOWN (0000/0001)
0 0 1F 16	3F6	07EC	FC09	User
THROUGH				
0 0 1F 1F	3FF	07FE	FC00	User

RT/BC Control Area

0 1 00 00	400	0800	FBFF	SELECT RT
0 1 00 01	401	0802	FBFE	SELECT BC

RT/BC Block Transfer Logic (BTL) Control and Self Test Control

0 1 00 02	402	0804	FBFD	RX BTL OFF / TX BTL OFF
0 1 00 03	403	0806	FBFC	RX BTL OFF / TX BTL ON
0 1 00 04	404	0808	FBFB	RX BTL ON / TX BTL OFF
0 1 00 05	405	080A	FBFA	RX BTL ON / TX BTL ON
0 1 00 06	406	080C	FBF9	OFF- LINE Self Test
0 1 00 06	407	080E	FBF8	ON-LINE Self Test
0 1 00 06	408	0810	FBF7	DISABLE Self Test
0 1 00 06	409	0812	FBF6	User
THROUGH				
0 1 00 0F	40F	081E	FBF0	User

RT/TX BC/RX Mode Area - SA 00 (0)

0 1 00 10	410	0820	FBEF	VECTOR WORD
0 1 00 11	411	0822	FBDF	User
0 1 00 12	412	0824	FBCF	LAST COMMAND
0 1 00 13	413	0826	FBBF	BIT WORD
0 1 00 14	414	0828	FBAF	User
THROUGH				
0 1 00 1F	41F	083E	FBE0	User

30 RT Transmit / BC Receive Subaddresses - SA 01-1E (1-30)

0 1 01 00	420	0840	FBDF	SA1 Last Word (Word 01 if WC =1)
0 1 01 04	424	0848	FBDB	SA1 Word 01 if WC = 5
0 1 01 1F	43F	087E	FBC0	SA1 Word 01 if WC = 32
0 1 02 00	440	0880	FBBF	SA2
0 1 02 1F	45F	08BE	FBA0	
0 1 03 00	460	08C0	FB9F	SA3
0 1 03 1F	47F	08FE	FB80	
0 1 04 00	480	0900	FB7F	SA4
0 1 04 1F	49F	093E	FB60	
0 1 05 00	4A0	0940	FB5F	SA5
0 1 05 1F	4BF	097E	FB40	
0 1 06 00	4C0	0980	FB3F	SA6
0 1 06 1F	4DF	09BE	FB20	
0 1 07 00	4E0	09C0	FB1F	SA7
0 1 07 1F	4FF	09FE	FB00	
0 1 08 00	500	0A00	FAFF	SA8
0 1 08 1F	51F	0A3E	FAE0	
0 1 09 00	520	0A40	FADF	SA9
0 1 09 1F	53F	0A7E	FAC0	
0 1 0A 00	540	0A80	FABF	SA10
0 1 0A 1F	55F	0ABE	FAA0	
0 1 0B 00	560	0AC0	FA9F	SA11
0 1 0B 1F	57F	0AFE	FA80	
0 1 0C 00	580	0B00	FA7F	SA12
0 1 0C 1F	59F	0B3E	FA60	
0 1 0D 00	5A0	0B40	FA5F	SA13
0 1 0D 1F	5BF	0B7E	FA40	
0 1 0E 00	5C0	0B80	FA3F	SA14
0 1 0E 1F	5DF	0BBE	FA20	
0 1 0F 00	5E0	0BC0	FA1F	SA15
0 1 0F 1F	5FF	0BFE	FA00	
0 1 10 00	600	0C00	F9FF	SA16
0 1 10 1F	61F	0C3E	F9E0	
0 1 11 00	620	0C40	F9DF	SA17
0 1 11 00	63F	0C7E	F9C0	
0 1 12 00	640	0C80	F9BF	SA18
0 1 12 1F	65F	0CBE	F9A0	
0 1 13 00	660	0CC0	F99F	SA19
0 1 13 1F	67F	0CFE	F980	
0 1 14 00	680	0D00	F97F	SA20
0 1 14 1F	69F	0D3E	F960	
0 1 15 00	6A0	0D40	F95F	SA21
0 1 15 1F	6BF	0D7E	F940	
0 1 16 00	6C0	0D80	F93F	SA22
0 1 16 1F	6DF	0DBE	F920	
0 1 17 00	6E0	0DC0	F91F	SA23

0 1 17 1F	6FF	0DFE	F900	
0 1 18 00	700	0E00	F8FF	SA24
0 1 18 1F	71F	0E3E	F8E0	
0 1 19 00	720	0E40	F8DF	SA25
0 1 19 1F	73F	0E7E	F8C0	
0 1 1A 00	740	0E80	F8BF	SA26
0 1 1A 1F	75F	0EBE	F8A0	
0 1 1B 00	760	0EC0	F89F	SA27
0 1 1B 1F	77F	0EFE	F880	
0 1 1C 00	780	0F00	F87F	SA28
0 1 1C 1F	79F	0F3E	F860	
0 1 1D 00	7A0	0F40	F85F	SA29
0 1 1D 1F	7BF	0F7E	F840	
0 1 1E 00	7C0	0F80	F83F	SA30
0 1 1E 1F	7DF	0FBE	F820	

RT/ TX BC/RX Mode Area - SA 1F (31)

0 1 1F 00	7E0	0FC0	F81F	
THROUGH				
0 1 1F 0F	7EF	0FDE	F810	
0 1 1F 10	7F0	0FE0	F80F	VECTOR WORD
0 1 1F 11	7F1	0FE2	F80E	User
0 1 1F 12	7F2	0FE4	F80D	LAST COMMAND
0 1 1F 13	7F3	0FE6	F80C	BIT WORD
0 1 1F 14	7F4	0FE8	F80B	User
THROUGH				
0 1 1F 1F	7FF	0FFE	F800	User

Broadcast RT/RX BC/TX Mode Area - SA 00 (0)

1 0 00 00	800	1000	F7FF	User
THROUGH				
1 0 00 10	810	1020	F7EF	User
1 0 00 11	811	1022	F7EE	SYNC WORD
1 0 00 12	812	1024	F7ED	User
1 0 00 13	813	1036	F7EC	User
1 0 00 14	814	1028	F7EB	SELECTED TX SHUTDOWN (0000/0001)
1 0 00 15	815	102A	F7EA	OVERRIDE SELECTED TX SHUTDOWN (0000/0001)
1 0 00 16	816	102C	F7E9	User
THROUGH				
1 0 00 1F	81F	103E	F7E0	User

30 Broadcast RT Receive / BC Transmit Subaddresses - SA 01-1E (1-30)

1 0 01 00	820	1040	F7DF	SA1 Last Word (Word 01 if WC =1)
1 0 01 04	824	1048	F7DB	SA1 Word 01 if WC = 5
1 0 01 1F	83F	107E	F7C0	SA1 Word 01 if WC = 32
1 0 02 00	840	1080	F7BF	SA2
1 0 02 1F	85F	10BE	F7A0	

1 0 03 00	860	10C0	F79F	SA3
1 0 03 1F	87F	10FE	F780	
1 0 04 00	880	1100	F77F	SA4
1 0 04 1F	89F	113E	F760	
1 0 05 00	8A0	1140	F75F	SA5
1 0 05 1F	8BF	117E	F740	
1 0 06 00	8C0	1180	F73F	SA6
1 0 06 1F	8DF	11BE	F720	
1 0 07 00	8E0	11C0	F71F	SA7
1 0 07 1F	8FF	11FE	F700	
1 0 08 00	900	1200	F6FF	SA8
1 0 08 1F	91F	123E	F6E0	
1 0 09 00	920	1240	F6DF	SA9
1 0 09 1F	93F	127E	F6C0	
1 0 0A 00	940	1280	F6BF	SA10
1 0 0A 1F	95F	12BE	F6A0	
1 0 0B 00	960	12C0	F69F	SA11
1 0 0B 1F	97F	12FE	F680	
1 0 0C 00	980	1300	F67F	SA12
1 0 0C 1F	99F	133E	F660	
1 0 0D 00	9A0	1340	F65F	SA13
1 0 0D 1F	9BF	137E	F640	
1 0 0E 00	9C0	1380	F63F	SA14
1 0 0E 1F	9DF	13BE	F620	
1 0 0F 00	9E0	13C0	F61F	SA15
1 0 0F 1F	9FF	133E	F600	
1 0 10 00	A00	1400	F5FF	SA16
1 0 10 1F	A1F	143E	F5E0	
1 0 11 00	A20	1440	F5DF	SA17
1 0 11 00	A3F	147E	F5C0	
1 0 12 00	A40	1480	F5BF	SA18
1 0 12 1F	A5F	14BE	F5A0	
1 0 13 00	A60	14C0	F59F	SA19
1 0 13 1F	A7F	14FE	F580	
1 0 14 00	A80	1500	F57F	SA20
1 0 14 1F	A9F	153E	F560	
1 0 15 00	AA0	1540	F55F	SA21
1 0 15 1F	ABF	157E	F540	
1 0 16 00	AC0	1580	F53F	SA22
1 0 16 1F	ADF	15BE	F520	
1 0 17 00	AE0	15C0	F51F	SA23
1 0 17 1F	AFF	15FE	F500	
1 0 18 00	B00	1600	F4FF	SA24
1 0 18 1F	B1F	163E	F4E0	
1 0 19 00	B20	1640	F4DF	SA25
1 0 19 1F	B3F	167E	F4C0	
1 0 1A 00	B40	1680	F4BF	SA26
1 0 1A 1F	B5F	16BE	F4A0	
1 0 1B 00	B60	16C0	F49F	SA27

1 0 1B 1F	B7F	16FE	F480	
1 0 1C 00	B80	1700	F47F	SA28
1 0 1C 1F	B9F	173E	F460	
1 0 1D 00	BA0	1740	F45F	SA29
1 0 1D 1F	BBF	177E	F440	
1 0 1E 00	BC0	1780	F43F	SA30
1 0 1E 1F	BDF	17BE	F420	

Broadcast RT/RX BC/TX Mode Area 1F - SA 1F (31)

1 0 1F 00	BE0	17C0	F41F	User
THROUGH				
1 0 1F 10	BF0	17E0	F40F	User
1 0 1F 11	BF1	17E2	F40E	SYNC WORD
1 0 1F 12	BF2	17E4	F40D	User
1 0 1F 13	BF3	17E6	F40C	User
1 0 1F 14	BF4	17E8	F40B	SELECTED TX SHUTDOWN (0000/0001)
1 0 1F 15	BF5	17EA	F40A	OVERRIDE SELECTED TX SHUTDOWN (0000/0001)
1 0 1F 16	BF6	17EC	F409	User
THROUGH				
1 0 1F 1F	BFF	17FE	F400	User

CT2577 / 79 Part Ordering Information

CT2577 - Mil-Std 1553 / 1760 Bus Controller/Remote Terminal

CT2577- XX- YY- ZZ

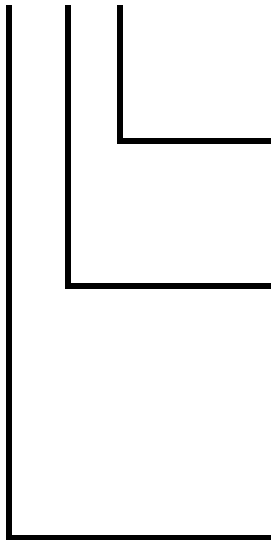

P 1 1 9 = 119 Pin PGA

F 8 4 = 84 Pin Quad Flatpack

Q M = Full Mil 883C Screened Part (-55⁰C to +125⁰C)

X T = Extended Temperature Range (-55⁰C to +125⁰C)

I N = Industrial Temperature Range (-40⁰C to +85⁰C)

C G = Commercial Grade (0⁰C to +70⁰C)

X X = Function Selection

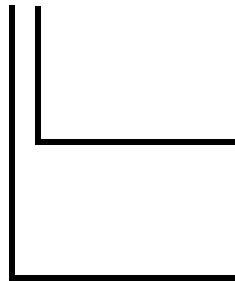

0 = Memory Enabled (T0-T15 Bus)

1 = Memory Enabled (T0-T10 Bus)

0 = No Stores Pinout

1 = Stores Pinout

CT2578 - Mil-Std 1553 / 1760 Bus Remote Terminal Only

CT2578- XX- YY- ZZ

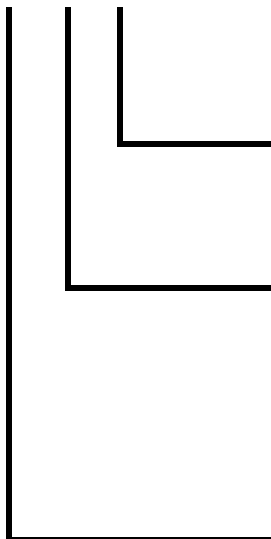

P 119 = 119 Pin PGA

F 84 = 84 Pin Quad Flatpack

QM = Full Mil 883C Screened Part (-55⁰C to +125⁰C)

XT = Extended Temperature Range (-55⁰C to +125⁰C)

IN = Industrial Temperature Range (-40⁰C to +85⁰C)

CG = Commercial Grade (0⁰C to +70⁰C)

XX = Function Selection

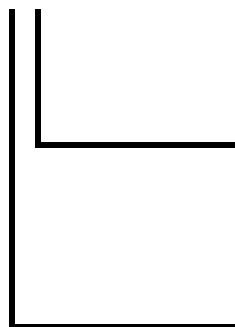

0 = Memory Enabled (T0-T15 Bus)

1 = Memory Enabled (T0-T10 Bus)

2 = No Memory Enabled (DMA)

0 = No Stores Pinout

1 = Stores Pinout

CT2579 - McAir Bus Remote Controller/Remote Terminal

CT2579- XX- YY- ZZ

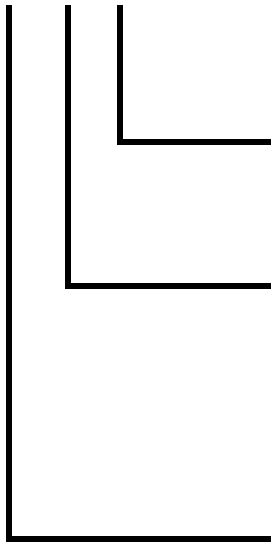

P 119 = 119 Pin PGA

F 84 = 84 Pin Quad Flatpack

QM = Full Mil 883C Screened Part (-55⁰C to +125⁰C)

XT = Extended Temperature Range (-55⁰C to +125⁰C)

I N = Industrial Temperature Range (-40⁰C to +85⁰C)

CG = Commercial Grade (0⁰C to +70⁰C)

XX = Function Selection

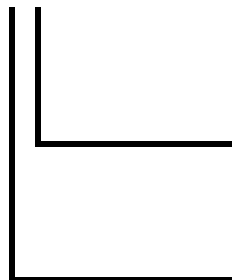

0 = Memory Enabled (T0-T15 Bus)

1 = Memory Enabled (T0-T10 Bus)

0 = No Stores Pinout

1 = Stores Pinout

CT2580 - McAir Bus Remote Terminal Only

CT2580- XX- YY- ZZ

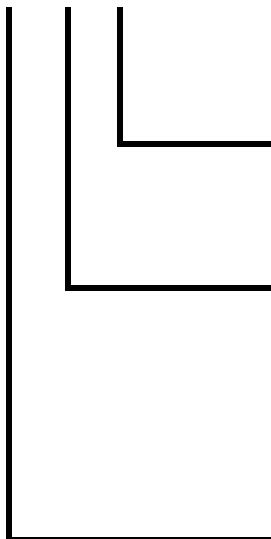

P 1 1 9 = 119 Pin PGA

F 8 4 = 84 Pin Quad Flatpack

Q M = Full Mil 883C Screened Part (-55⁰C to +125⁰C)

X T = Extended Temperature Range (-55⁰C to +125⁰C)

I N = Industrial Temperature Range (-40⁰C to +85⁰C)

C G = Commercial Grade (0⁰C to +70⁰C)

X X = Function Selection

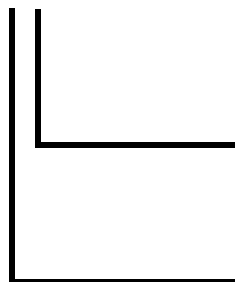

0 = Memory Enabled (T0-T15 Bus)

1 = Memory Enabled (T0-T10 Bus)

0 = No Stores Pinout

1 = Stores Pinout

CT2577 / 79 Pinouts

CT2577-01-xx-F84 Pinouts – 84 Pin Quad Flatpack

Pin #	Description	Pin #	Description
1	ADIN 11	43	NCMDSTRB
2	ADIN 10	44	NEMPTY
3	ADIN 09	45	DATA 00
4	BCNRT	46	DATA 01
5	NSYNC	47	NSSFLAG
6	ADIN 08	48	UB
7	Not Connected	49	NBIT16
8	Not Connected	50	Not Connected
9	ADIN 07	51	DATA 02
10	ADIN 06	52	Not Connected
11	MCDET	53	DATA 03
12	NVCR	54	DATA 04
13	BCST	55	DATA 05
14	NTF	56	WRAPEN
15	ADIN 05	57	DATA 06
16	ADIN 04	58	T 00
17	NME	59	DATA 07
18	ADDR E	60	DATA 08
19	NDBC	61	T 01
20	EOT	62	T 02
21	ADDR D	63	DATA 09
22	ADDR C	64	DATA 10
23	ADDR B	65	DATA 11
24	NWR	66	T 03
25	ADDR A	67	T 04
26	NRD	68	T 05
27	NACK	69	DATA 12
28	ADDR P	70	T 06
29	DATA (Bus 0)	71	DATA 13
30	NDATA (Bus 0)	72	DATA 14
31	NSTSTRB	73	T 07
32	NCARDEN	74	DATA (Bus 1)
33	ERROR	75	NDATA (Bus 1)
34	VDD1	76	NFULL
35	VSS1	77	DATA 15
36	C16MHZ	78	VDD2
37	LA	79	VSS2
38	ADIN 03	80	NILLCMD
39	ADIN 02	81	T 08
40	ADIN 01	82	T 09
41	NRES/NRCL	83	T 10
42	ADIN 00	84	VME(/MULTI)

CT2577-11-xx-F84 Pinouts – 84 Pin Quad Flatpack

Pin #	Description	Pin #	Description
1	ADIN 11	43	NCMDSTRB
2	ADIN 10	44	NEMPTY
3	ADIN 09	45	DATA 00
4	BCNRT	46	DATA 01
5	NSYNC	47	NSSFLAG
6	ADIN 08	48	UB
7	NVALCHK (1760)	49	NBIT16
8	STATUS (1760)	50	NHDR (1760)
9	ADIN 07	51	DATA 02
10	ADIN 06	52	STREL (1760)
11	NENCHK (1760)	53	DATA 03
12	NVCR	54	DATA 04
13	BCST	55	DATA 05
14	NTF	56	WRAPEN
15	ADIN 05	57	DATA 06
16	ADIN 04	58	T 00
17	NME	59	DATA 07
18	ADDR E	60	DATA 08
19	NDBC	61	T 01
20	EOT	62	T 02
21	ADDR D	63	DATA 09
22	ADDR C	64	DATA 10
23	ADDR B	65	DATA 11
24	NWR	66	T 03
25	ADDR A	67	T 04
26	NRD	68	T 05
27	NACK	69	DATA 12
28	ADDR P	70	T 06
29	DATA (Bus 0)	71	DATA 13
30	NDATA (Bus 0)	72	DATA 14
31	NSTSTRB	73	T 07
32	NCARDEN	74	DATA (Bus 1)
33	ERROR	75	NDATA (Bus 1)
34	VDD1	76	NFULL
35	VSS1	77	DATA 15
36	C16MHZ	78	VDD2
37	LA	79	VSS2
38	ADIN 03	80	NILLCMD
39	ADIN 02	81	T 08
40	ADIN 01	82	T 09
41	NRES/NRCL	83	T 10
42	ADIN 00	84	VME(/MULTI)

CT2579-01-xx-F84 Pinouts – 84 Pin Quad Flatpack

Pin #	Description	Pin #	Description
1	ADIN 11	43	NCMDSTRB
2	ADIN 10	44	NEMPTY
3	ADIN 09	45	DATA 00
4	BCNRT	46	DATA 01
5	NSYNC	47	NSSFLAG
6	ADIN 08	48	UB
7	Not Connected	49	NBIT16
8	Not Connected	50	Not Connected
9	ADIN 07	51	DATA 02
10	ADIN 06	52	Not Connected
11	MCDET	53	DATA 03
12	NVCR	54	DATA 04
13	BCST	55	DATA 05
14	NTF	56	WRAPEN
15	ADIN 05	57	DATA 06
16	ADIN 04	58	T 00
17	NME	59	DATA 07
18	ADDR E	60	DATA 08
19	NDBC	61	T 01
20	EOT	62	T 02
21	ADDR D	63	DATA 09
22	ADDR C	64	DATA 10
23	ADDR B	65	DATA 11
24	NWR	66	T 03
25	ADDR A	67	T 04
26	NRD	68	T 05
27	NACK	69	DATA 12
28	ADDR P	70	T 06
29	DATA (Bus 0)	71	DATA 13
30	NDATA (Bus 0)	72	DATA 14
31	NSTSTRB	73	T 07
32	NCARDEN	74	DATA (Bus 1)
33	ERROR	75	NDATA (Bus 1)
34	VDD1	76	NFULL
35	VSS1	77	DATA 15
36	C16MHZ	78	VDD2
37	LA	79	VSS2
38	ADIN 03	80	NILLCMD
39	ADIN 02	81	T 08
40	ADIN 01	82	T 09
41	NRES/NRCL	83	T 10
42	ADIN 00	84	VME(/MULTI)

CT2579-11-xx-F84 Pinouts – 84 Pin Quad Flatpack

Pin #	Description	Pin #	Description
1	ADIN 11	43	NCMDSTRB
2	ADIN 10	44	NEMPTY
3	ADIN 09	45	DATA 00
4	BCNRT	46	DATA 01
5	NSYNC	47	NSSFLAG
6	ADIN 08	48	UB
7	NVALCHK (1760)	49	NBIT16
8	STATUS (1760)	50	NHDR (1760)
9	ADIN 07	51	DATA 02
10	ADIN 06	52	STREL (1760)
11	NENCHK (1760)	53	DATA 03
12	NVCR	54	DATA 04
13	BCST	55	DATA 05
14	NTF	56	WRAPEN
15	ADIN	57	DATA 06
16	ADIN	58	T 00
17	NME	59	DATA 07
18	ADDR E	60	DATA 08
19	NDBC	61	T 01
20	EOT	62	T 02
21	ADDR D	63	DATA 09
22	ADDR C	64	DATA 10
23	ADDR B	65	DATA 11
24	NWR	66	T 03
25	ADDR A	67	T 04
26	NRD	68	T 05
27	NACK	69	DATA 12
28	ADDR P	70	T 06
29	DATA (Bus 0)	71	DATA 13
30	NDATA (Bus 0)	72	DATA 14
31	NSTSTRB	73	T 07
32	NCARDEN	74	DATA (Bus 1)
33	ERROR	75	NDATA (Bus 1)
34	VDD1	76	NFULL
35	VSS1	77	DATA 15
36	C16MHZ	78	VDD2
37	LA	79	VSS2
38	ADIN	80	NILLCMD
39	ADIN	81	T 08
40	ADIN	82	T 09
41	NRES/NRCL	83	T 10
42	ADIN 00	84	VME(/MULTI)

CT2577-10-xx-P119 Pinouts – 119 Pin Grid Array

Pin #	Description	Pin #	Description	Pin #	Description
A1	VME	D3	T 13	L1	ADIN 4
A2	T 11	D11	T 2	L2	NME
A3	T 9	D12	DATA 7	L3	EOT
A4	T 8	D13	DATA 6	L4	ADDR B
A5	N/C	E1	NSYNC	L5	NACK
A6	N/C	E2	BCNRT	L6	NDATA 0 (BUS)
A7	NENBTL	E3	T 15	L7	VDD
A8	DATA 15	E11	T 0	L8	NINHST
A9	DATA 1(BUS)	E12	WRAPEN	L9	ADIN 3
A10	T 7	E13	DATA 5	L10	ADIN 0
A11	T 6	F1	MCAIR	L11	NCMDSTRB
A12	DATA 12	F2	N/C	L12	NDBCA
A13	T 3	F3	ADIN 8	L13	NTXINH 1
B1	ADIN 11	F11	DATA 4	M1	SELEN 0
B2	T 12	F12	NSR	M2	NDBC
B3	N/C	F13	DATA 3	M3	ADDR C
B4	N/C	G1	NVALCHK	M4	NRD
B5	N/C	G2	ADIN 7	M5	N/C
B6	N/C	G3	STATUS	M6	NSTSTRB
B7	VSS	G11	DATA 2	M7	VSS
B8	NFULL	G12	STREL	M8	INHMC
B9	N/C	G13	NHDR	M9	LA
B10	DATA 13	H1	ADIN 6	M10	ADIN 2
B11	T 4	H2	NENCHK	M11	NRES
B12	DATA 10	H3	MCDDET	M12	N/C
B13	DATA 9	H11	NBUSY	M13	NTXINH 0
C1	T 14	H12	N/C	N1	ADDR D
C2	INITWD	H13	NBIT16	N2	NWR
C4	T 10	J1	WATCHDOG	N3	ADDR A
C5	N/C	J2	NVCR	N4	ADDR P
C6	NILLCMD	J3	NTF	N5	DATA 0(BUS)
C7	VDD	J11	DATA 0	N6	NCARDEN
C8	NDATA 1(BUS)	J12	NSSFLAG	N7	ERROR
C9	DATA 14	J13	UB	N8	N/C
C10	T 5	K1	BCST	N9	C16MHZ
C11	DATA 11	K2	ADIN 5	N10	NDATA
C12	T 1	K3	ADDR E	N11	ADIN 1
C13	DATA 8	K11	NNEWBUS	N12	N/C
D1	ADIN 9	K12	SELEN 1	N13	NEMPTY
D2	ADIN 10	K13	DATA 1		

CT2579-10-xx-P119 Pinouts – 119 Pin Grid Array

Pin #	Description	Pin #	Description	Pin #	Description
A1	VME	D3	T 13	L1	ADIN 4
A2	T 11	D11	T 2	L2	NME
A3	T 9	D12	DATA 7	L3	EOT
A4	T 8	D13	DATA 6	L4	ADDR B
A5	N/C	E1	NSYNC	L5	NACK
A6	N/C	E2	BCNRT	L6	NDA0 0 (BUS)
A7	NENBTL	E3	T 15	L7	VDD
A8	DATA 15	E11	T 0	L8	NINHST
A9	DATA 1(BUS)	E12	WRAPEN	L9	ADIN 3
A10	T 7	E13	DATA 5	L10	ADIN 0
A11	T 6	F1	MCAIR	L11	NCMDSTRB
A12	DATA 12	F2	N/C	L12	NDBCA
A13	T 3	F3	ADIN 8	L13	NTXINH 1
B1	ADIN 11	F11	DATA 4	M1	SELEN 0
B2	T 12	F12	NSR	M2	NDBC
B3	N/C	F13	DATA 3	M3	ADDR C
B4	N/C	G1	NVALCHK	M4	NRD
B5	N/C	G2	ADIN 7	M5	N/C
B6	N/C	G3	STATUS	M6	NSTSTRB
B7	VSS	G11	DATA 2	M7	VSS
B8	NFULL	G12	STREL	M8	INHMC
B9	N/C	G13	NHDR	M9	LA
B10	DATA 13	H1	ADIN 6	M10	ADIN 2
B11	T 4	H2	NENCHK	M11	NRES
B12	DATA 10	H3	MCDDET	M12	N/C
B13	DATA 9	H11	NBUSY	M13	NTXINH 0
C1	T 14	H12	N/C	N1	ADDR D
C2	INITWD	H13	NBIT16	N2	NWR
C4	T 10	J1	WATCHDOG	N3	ADDR A
C5	N/C	J2	NVCR	N4	ADDR P
C6	NILLCMD	J3	NTF	N5	DATA 0(BUS)
C7	VDD	J11	DATA 0	N6	NCARDEN
C8	NDA1 1(BUS)	J12	NSSFLAG	N7	ERROR
C9	DATA 14	J13	UB	N8	N/C
C10	T 5	K1	BCST	N9	C16MHZ
C11	DATA 11	K2	ADIN 5	N10	NDA
C12	T 1	K3	ADDR E	N11	ADIN 1
C13	DATA 8	K11	NNEWBUS	N12	N/C
D1	ADIN 9	K12	SELEN 1	N13	NEMPTY
D2	ADIN 10	K13	DATA 1		