

RAD Tolerant ACT-RS128K32 High Speed 4 Megabit SRAM Multichip Module

Preliminary

Features

- 4 Low Power CMOS 128K x 8 SRAMs in one MCM
- Overall configuration as 128K x 32
- Tolerant to 30KRad (Si)
- Latch-up Immunity to 112MeV/(mg/cm²)
- Input and Output TTL Compatible
- 35 & 45ns Access Times
- Full Military (-55°C to +125°C) Temperature Range
- For Class K devices per MIL-PRF-38534 - Consult Factory
- +5V Power Supply
- Choice of 4 Hermetically sealed Co-fired Packages:
 - 68-Lead, Low Profile CQFP (F1), 1.56"SQ x .140"max
 - 68-Lead, Dual-Cavity CQFP (F2), .88"SQ x .20"max (.18"max thickness available, contact factory for details) (*Drops into the 68 Lead JEDEC .99"SQ CQFJ footprint*)
 - 66-Lead, PGA-Type (P1), 1.385"SQ x .245"max
- Internal Decoupling Capacitors



General Description

The ACT-RS128K32 is a High Speed 4 megabit CMOS SRAM Multichip Module (MCM) designed for full temperature range, military, space, or high reliability mass memory and fast cache applications.

The MCM can be organized as a 128K x 32 bits, 256K x 16 bits or 512k x 8 bits device and is input and output TTL compatible. Writing is executed when the write enable (WE) and chip enable (CE) inputs are low. Reading is accomplished when WE is high and CE and output enable (OE) are both low. Access time grades of 35ns and 45ns maximum are standard.

The +5 Volt power supply version is standard.

The products are designed for operation over the temperature range of -55°C to +125°C and screened under the full military environment. DESC Standard Military Drawing (SMD) part numbers are pending.

The ACT-RS128K32 is manufactured in Aeroflex's 80,000ft² MIL-PRF-38534 certified facility in Plainview, N.Y.

Block Diagram – PGA Type Package(P1) & CQFP(F2)

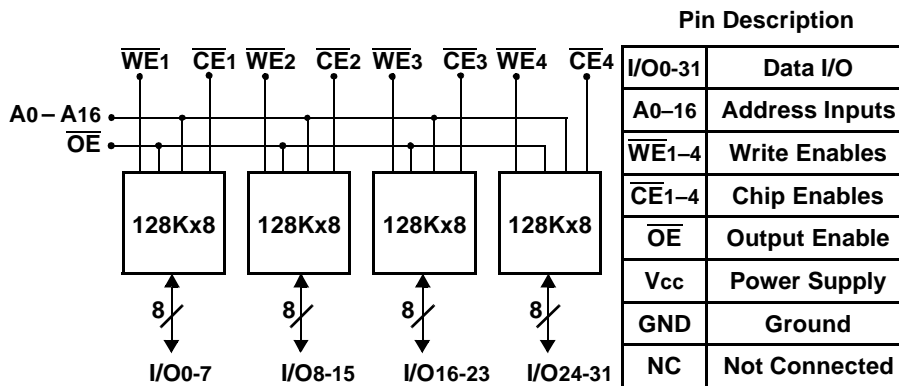

Block Diagram – CQFP(F1)

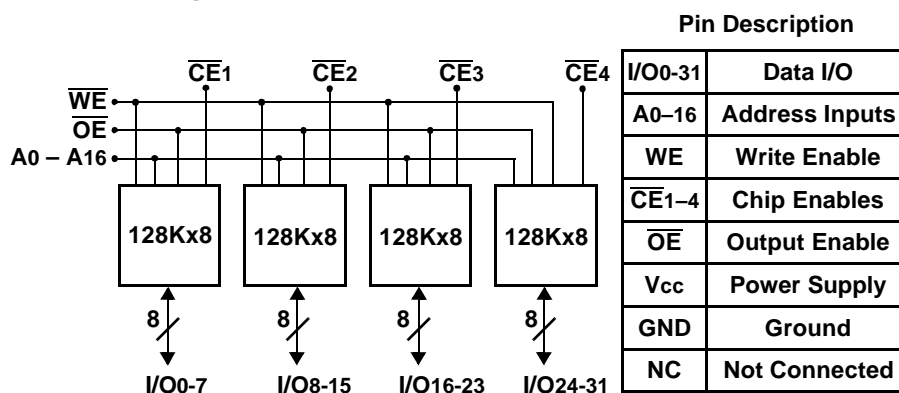

Absolute Maximum Ratings

Symbol	Rating	Range	Units
T_C	Case Operating Temperature	-55 to +125	°C
T_{STG}	Storage Temperature	-65 to +150	°C
P_D	Maximum Package Power Dissipation		
	F1 & P1 Packages	4.4	W
	F2 Package	3.3	W
θ_{J-C}	Hottest Die, Max Thermal Resistance - Junction to Case		
	F1 & P1 Packages	2.0	°C/W
	F2 Package	8.0	°C/W
V_G	Maximum Signal Voltage to Ground	-0.5 to +7	V
T_L	Maximum Lead Temperature (10 seconds)	300	°C

Normal Operating Conditions

Symbol	Parameter	Minimum	Maximum	Units
V_{CC}	Power Supply Voltage	+4.5	+5.5	V
V_{IH}	Input High Voltage	+2.2	$V_{CC} + 0.3$	V
V_{IL}	Input Low Voltage	-0.5	+0.8	V

Truth Table

Mode	CE	OE	WE	Data I/O	Power
Standby	H	X	X	High Z	Standby (deselect/power down)
Read	L	L	H	Data Out	Active
Read	L	H	H	High Z	Active (deselected)
Write	L	X	L	Data In	Active

Capacitance

(f = 1MHz, $T_C = 25^\circ\text{C}$)

Symbol	Parameter	Maximum	Units
C_{AD}	$A_0 - A_{16}$ Capacitance	50	pF
C_{OE}	\overline{OE} Capacitance	50	pF
C_{WE}	CQFP(F1) Package	50	pF
	PGA(P1) and CQFP(F2) Packages	20	pF
C_{CE}	Chip Enable Capacitance	20	pF
$C_{I/O}$	I/O ₀ – I/O ₃₁ Capacitance	20	pF

Capacitance is guaranteed by design but not tested.

DC Characteristics

(4.5Vdc ≤ V_{CC} ≤ 5.5Vdc, $V_{SS} = 0V$, $T_C = -55^\circ\text{C}$ to +125°C, Unless otherwise specified)

Parameter	Sym	Conditions	-035		-045		Units
			Min	Max	Min	Max	
Input Leakage Current	I_{LI}	$V_{CC} = \text{Max}$, $V_{IN} = 0$ or V_{CC}		10		10	μA
Output Leakage Current	I_{LO}	$\overline{CE} = V_{IH}$, $\overline{OE} = V_{IH}$, $V_{OUT} = 0$ or V_{CC}		10		10	μA
Operating Supply Current 32 Bit Mode	$I_{CC} \times 32$	$\overline{CE} = V_{IL}$, $\overline{OE} = V_{IH}$, f = 5 MHz, $V_{CC} = \text{Max}$, CMOS Compatible		500		600	mA

DC Characteristics (Continued)

($4.5V_{dc} \leq V_{CC} \leq 5.5V_{dc}$, $V_{SS} = 0V$, $T_C = -55^{\circ}C$ to $+125^{\circ}C$, Unless otherwise specified)

Parameter	Sym	Conditions	-035		-045		Units
			Min	Max	Min	Max	
Standby Current	I_{SB}	$\overline{CE} = V_{IH}$, $\overline{OE} = V_{IH}$, $f = 5 \text{ MHz}$, $V_{CC} = \text{Max}$, CMOS Compatible		30		30	mA
Output Low Voltage	V_{OL}	$I_{OL} = 8 \text{ mA}$, $V_{CC} = \text{Min}$		0.4		0.4	V
Output High Voltage	V_{OH}	$I_{OH} = -4.0 \text{ mA}$, $V_{CC} = \text{Min}$	2.4		2.4		V

AC Characteristics

($V_{CC} = 5.0V$, $V_{SS} = 0V$, $T_C = -55^{\circ}C$ to $+125^{\circ}C$)

Read Cycle

Parameter	Sym	-035		-045		Units
		Min	Max	Min	Max	
Read Cycle Time	t_{RC}	35		45		ns
Address Access Time	t_{AA}		35		45	ns
Chip Enable Access Time	t_{ACE}		35		45	ns
Chip Enable to Output in Low Z*	t_{CLZ}	3		3		ns
Output Enable to Output in Low Z*	t_{OLZ}	0		0		ns
Chip Deselect to Output in High Z*	t_{CHZ}		20		20	ns
Output Disable to Output in High Z*	t_{OHZ}		10		15	ns

* Parameters guaranteed by design but not tested

Write Cycle

Parameter	Sym	-035		-045		Units
		Min	Max	Min	Max	
Write Cycle Time	t_{WC}	35		45		ns
Chip Enable to End of Write	t_{CW}	25		35		ns
Address Valid to End of Write	t_{AW}	25		35		ns
Data Valid to End of Write	t_{DW}	18		20		ns
Write Pulse Width	t_{WP}	25		35		ns
Address Setup Time	t_{AS}	0		0		ns
Write to Output in High Z *	t_{WHZ}		10		15	ns
Data Hold from Write Time	t_{DH}	0		0		ns
Address Hold Time	t_{AH}	0		0		ns

* Parameters guaranteed by design but not tested

Data Retention Electrical Characteristics (Special Order Only)

($T_C = -55^{\circ}C$ to $+125^{\circ}C$)

Parameter	Sym	Test Conditions	All Speeds		Units
			Min	Max	
V_{CC} for Data Retention	V_{DR}	$\overline{CE} \geq V_{CC} - 0.2V$	2	5.5	V
Data Retention Current	I_{CCDR1}	$V_{CC} = 3V, 35 \text{ \& } 45ns$		4	mA

Timing Diagrams

Read Cycle Timing Diagrams

Read Cycle 1 ($\overline{CE} = \overline{OE} = V_{IL}, \overline{WE} = V_{IH}$)

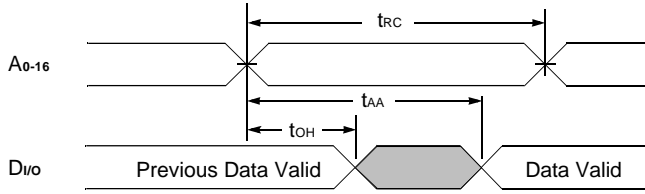

Read Cycle 2 ($\overline{WE} = V_{IH}$)

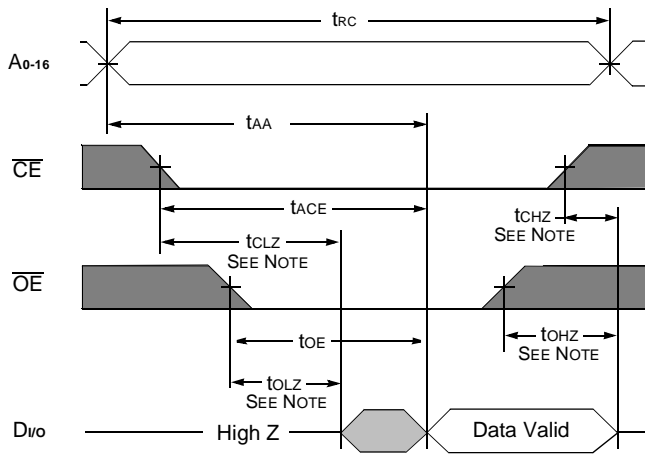

Note: Guaranteed by design, but not tested.

Write Cycle Timing Diagrams

Write Cycle 1 (\overline{WE} Controlled, $\overline{OE} = V_{IL}$)

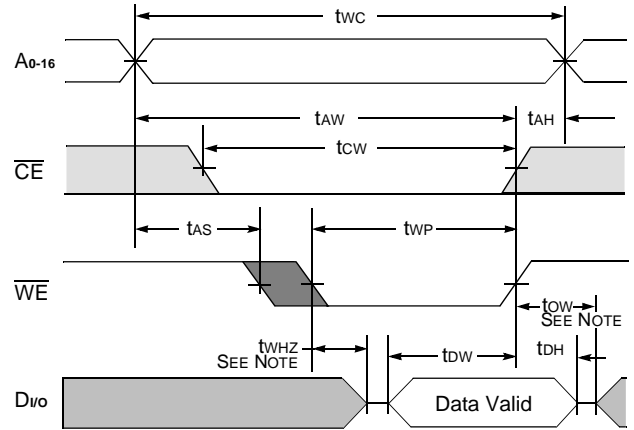

Write Cycle 2 (\overline{CE} Controlled, $\overline{OE} = V_{IH}$)

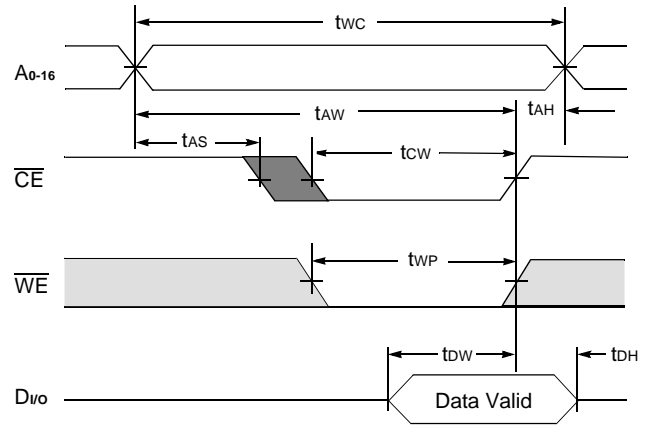

Note: Guaranteed by design, but not tested.

AC Test Circuit

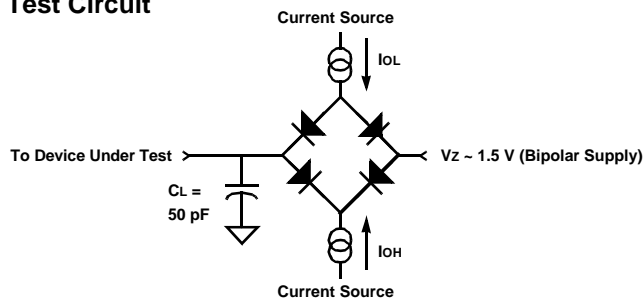

Notes:

- 1) V_Z is programmable from -2V to +7V. 2) I_{OL} and I_{OH} programmable from 0 to 16 mA. 3) Tester Impedance $Z_O = 75\Omega$. 4) V_Z is typically the midpoint of V_{OH} and V_{OL} . 5) I_{OL} and I_{OH} are adjusted to simulate a typical resistance load circuit. 6) ATE Tester includes jig capacitance.

Parameter	Typical	Units
Input Pulse Level	0 – 3.0	V
Input Rise and Fall	5	ns
Input and Output Timing Reference Level	1.5	V
Output Lead Capacitance	50	pF

Pin Numbers & Functions

66 Pins — PGA-Type							
Pin #	Function	Pin #	Function	Pin #	Function	Pin #	Function
1	I/O8	18	A12	35	I/O25	52	\overline{WE}_3
2	I/O9	19	V _{cc}	36	I/O26	53	\overline{CE}_3
3	I/O10	20	\overline{CE}_1	37	A6	54	GND
4	A13	21	NC	38	A7	55	I/O19
5	A14	22	I/O3	39	NC	56	I/O31
6	A15	23	I/O15	40	A8	57	I/O30
7	A16	24	I/O14	41	A9	58	I/O29
8	NC	25	I/O13	42	I/O16	59	I/O28
9	I/O0	26	I/O12	43	I/O17	60	A0
10	I/O1	27	\overline{OE}	44	I/O18	61	A1
11	I/O2	28	NC	45	V _{cc}	62	A2
12	\overline{WE}_2	29	\overline{WE}_1	46	\overline{CE}_4	63	I/O23
13	\overline{CE}_2	30	I/O7	47	\overline{WE}_4	64	I/O22
14	GND	31	I/O6	48	I/O27	65	I/O21
15	I/O11	32	I/O5	49	A3	66	I/O20
16	A10	33	I/O4	50	A4		
17	A11	34	I/O24	51	A5		

"P1" — 1.385" SQ PGA Type Package Standard

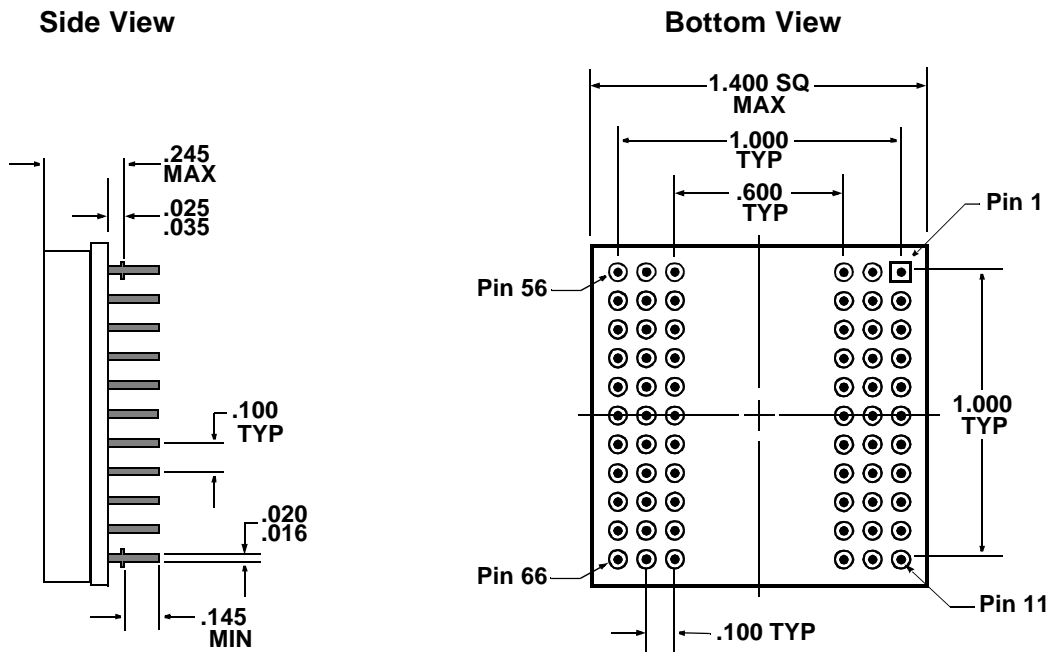

All dimensions in inches

Pin Numbers & Functions

68 Pins — CQFP							
Pin #	Function	Pin #	Function	Pin #	Function	Pin #	Function
1	GND	18	GND	35	\overline{OE}	52	GND
2	$\overline{CE1}$	19	I/O ₈	36	$\overline{CE4}$	53	I/O ₂₃
3	A ₅	20	I/O ₉	37	NC	54	I/O ₂₂
4	A ₄	21	I/O ₁₀	38	NC	55	I/O ₂₁
5	A ₃	22	I/O ₁₁	39	NC	56	I/O ₂₀
6	A ₂	23	I/O ₁₂	40	NC	57	I/O ₁₉
7	A ₁	24	I/O ₁₃	41	NC	58	I/O ₁₈
8	A ₀	25	I/O ₁₄	42	NC	59	I/O ₁₇
9	NC	26	I/O ₁₅	43	NC	60	I/O ₁₆
10	I/O ₀	27	V _{CC}	44	I/O ₃₁	61	V _{CC}
11	I/O ₁	28	A ₁₁	45	I/O ₃₀	62	A ₁₀
12	I/O ₂	29	A ₁₂	46	I/O ₂₉	63	A ₉
13	I/O ₃	30	A ₁₃	47	I/O ₂₈	64	A ₈
14	I/O ₄	31	A ₁₄	48	I/O ₂₇	65	A ₇
15	I/O ₅	32	A ₁₅	49	I/O ₂₆	66	A ₆
16	I/O ₆	33	A ₁₆	50	I/O ₂₅	67	\overline{WE}
17	I/O ₇	34	$\overline{CE2}$	51	I/O ₂₄	68	$\overline{CE3}$

Package Outline — CQFP "F1"

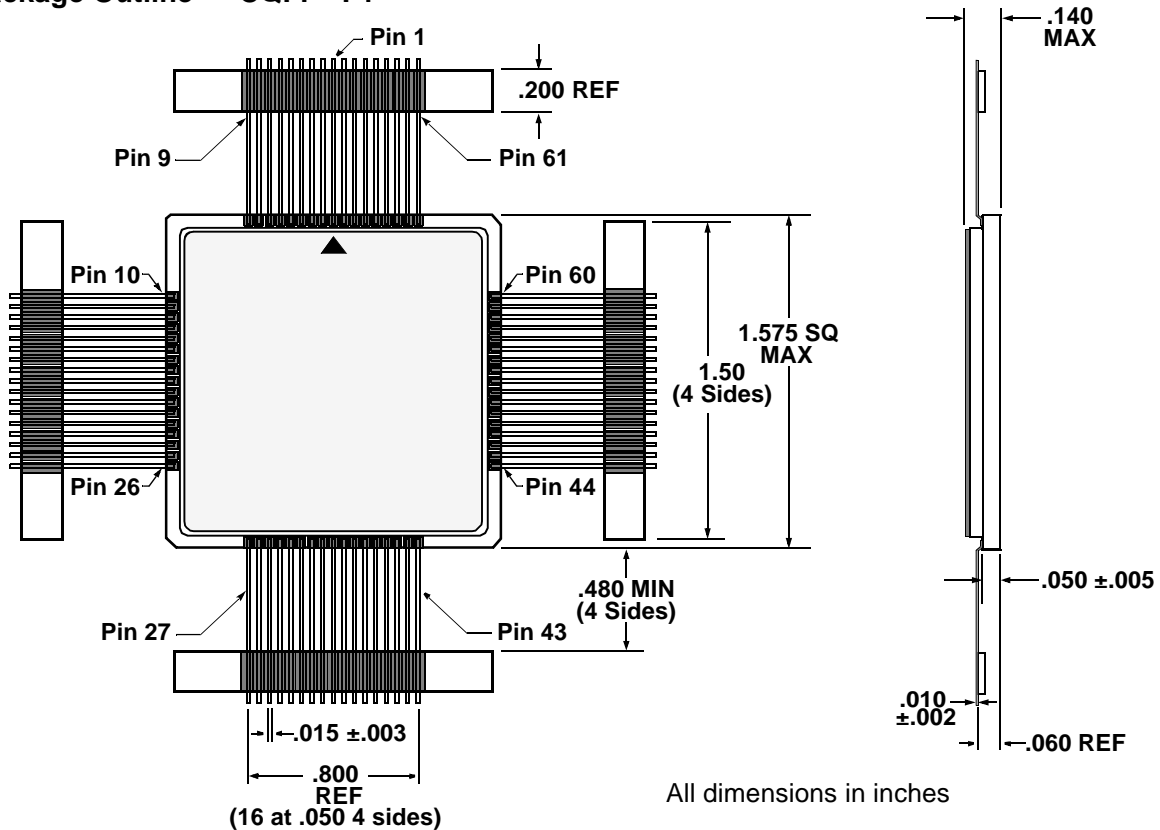

Pin Numbers & Functions

68 Pins — Dual-Cavity CQFP							
Pin #	Function	Pin #	Function	Pin #	Function	Pin #	Function
1	GND	18	GND	35	\overline{OE}	52	GND
2	$\overline{CE3}$	19	I/O ₈	36	$\overline{CE2}$	53	I/O ₂₃
3	A ₅	20	I/O ₉	37	NC	54	I/O ₂₂
4	A ₄	21	I/O ₁₀	38	$\overline{WE2}$	55	I/O ₂₁
5	A ₃	22	I/O ₁₁	39	$\overline{WE3}$	56	I/O ₂₀
6	A ₂	23	I/O ₁₂	40	$\overline{WE4}$	57	I/O ₁₉
7	A ₁	24	I/O ₁₃	41	NC	58	I/O ₁₈
8	A ₀	25	I/O ₁₄	42	NC	59	I/O ₁₇
9	NC	26	I/O ₁₅	43	NC	60	I/O ₁₆
10	I/O ₀	27	V _{CC}	44	I/O ₃₁	61	V _{CC}
11	I/O ₁	28	A ₁₁	45	I/O ₃₀	62	A ₁₀
12	I/O ₂	29	A ₁₂	46	I/O ₂₉	63	A ₉
13	I/O ₃	30	A ₁₃	47	I/O ₂₈	64	A ₈
14	I/O ₄	31	A ₁₄	48	I/O ₂₇	65	A ₇
15	I/O ₅	32	A ₁₅	49	I/O ₂₆	66	A ₆
16	I/O ₆	33	A ₁₆	50	I/O ₂₅	67	$\overline{WE1}$
17	I/O ₇	34	$\overline{CE1}$	51	I/O ₂₄	68	$\overline{CE4}$

Package Outline — Dual-Cavity CQFP "F2"

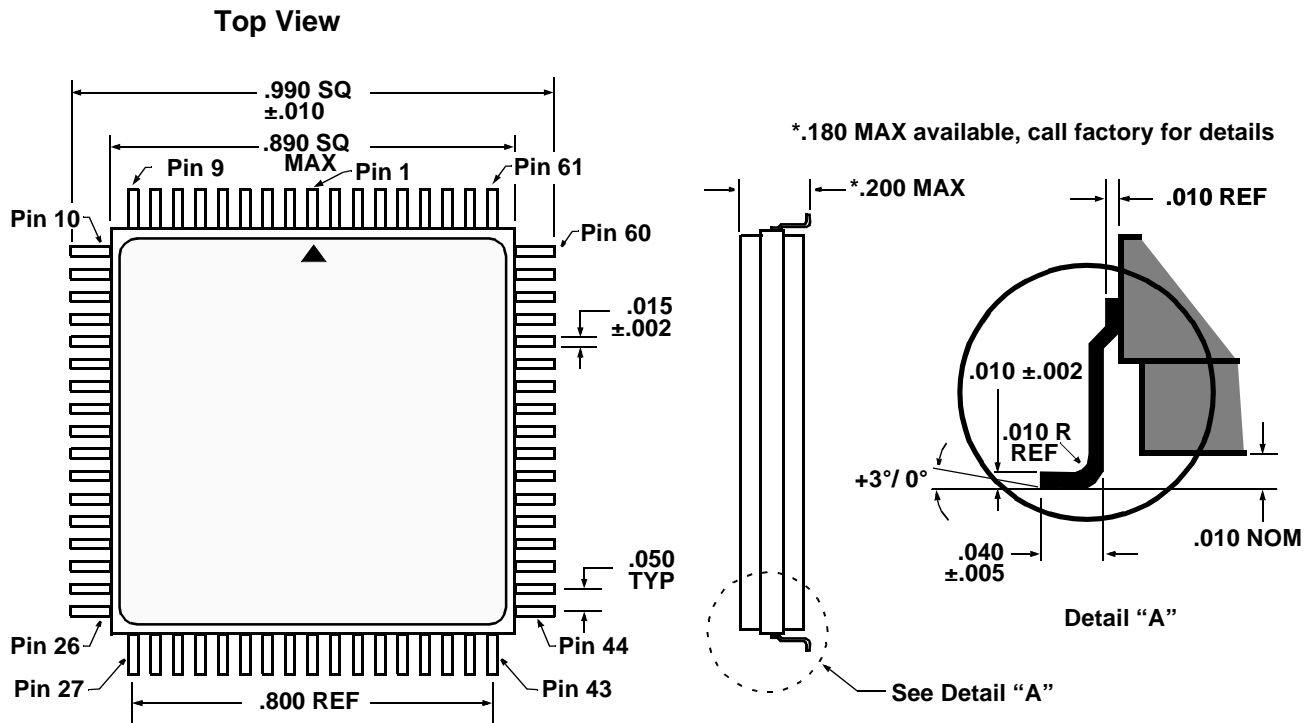

All dimensions in inches

Note: Metallic lids and walls – both sides



Ordering Information

Model Number	DESC Part Number	Speed	Package
ACT-RS128K32N-035F1Q	5962-TBD	35ns	1.56"sq CQFP
ACT-RS128K32N-035F2Q	5962-TBD		.88"sq CQFP
ACT-RS128K32N-035P1Q	5962-TBD		1.385"sq PGA-Type
ACT-RS128K32N-045F1Q	5962-TBD	45ns	1.56"sq CQFP
ACT-RS128K32N-045F2Q	5962-TBD		.88"sq CQFP
ACT-RS128K32N-045P1Q	5962-TBD		1.385"sq PGA-Type

Model Number Breakdown

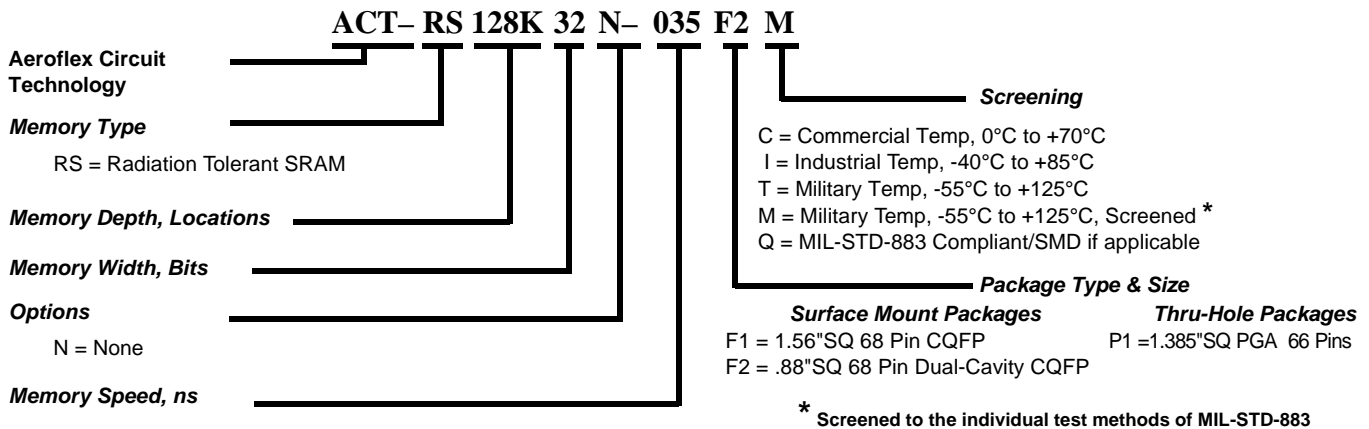

Specifications subject to change without notice

Aeroflex Circuit Technology
35 South Service Road
Plainview New York 11803
www.aeroflex.com/act1.htm

Telephone: (516) 694-6700
FAX: (516) 694-6715
Toll Free Inquiries: (800) 843-1553
E-Mail: sales-act@eroflex.com