

# ACT-SF128K32 High Speed 128Kx32 SRAM / 128Kx32 Flash Multichip Module



## FEATURES

- 4 – 128K x 8 SRAMs & 4 – 128K x 8 Flash Die in One MCM
- Access Times of 25ns (SRAM) and 60ns (Flash) or 35ns (SRAM) and 70ns or 90ns (Flash)
- Organized as 128K x 32 of SRAM and 128K x 32 of Flash Memory with Common Data Bus
- Low Power CMOS
- Input and Output TTL Compatible Design
- MIL-PRF-38534 Compliant MCMs Available
- Decoupling Capacitors and Multiple Grounds for Low Noise
- Commercial, Industrial and Military Temperature Ranges
- Industry Standard Pinouts
- TTL Compatible Inputs and Outputs
- Packaging – Hermetic Ceramic
  - 66-Lead, PGA-Type, 1.385"SQ x 0.245"max, Aeroflex code# P3,P7 without/with shoulders

## FLASH MEMORY FEATURES

- Sector Architecture (Each Die)
  - 8 Equal Sectors of 16K bytes each
  - Any combination of sectors can be erased with one command sequence.
- +5V Programming, +5V Supply
- Embedded Erase and Program Algorithms
- Hardware and Software Write Protection
- Page Program Operation and Internal Program Control Time.
- 10,000 Erase/Program Cycles



Block Diagram – PGA Type Package (P3 & P7)

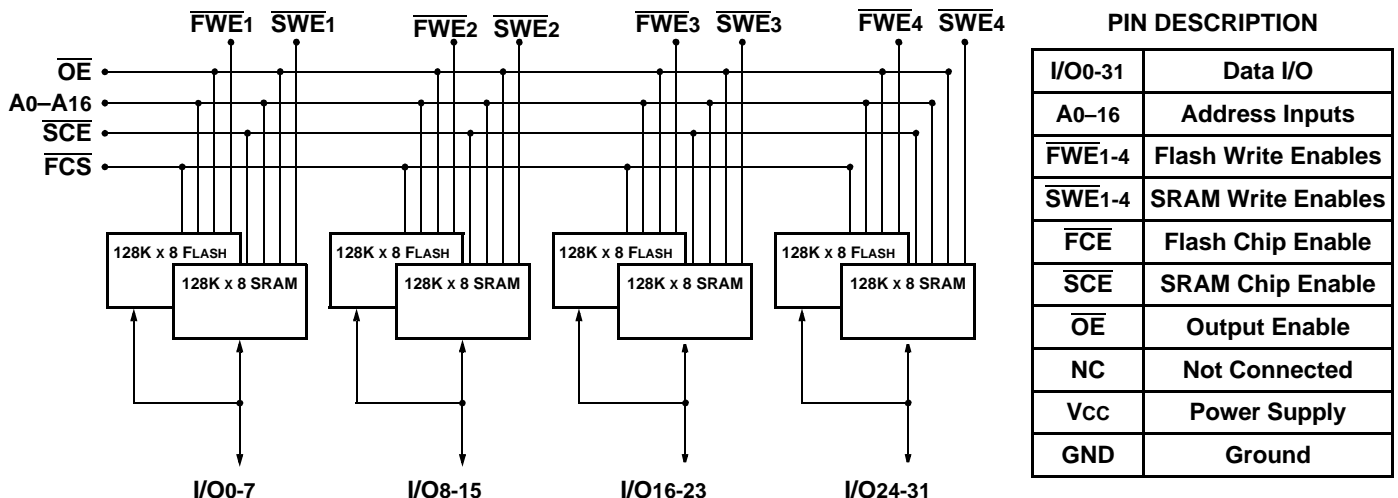

## Absolute Maximum Ratings

Symbol	Rating	Range	Units
$T_C$	Operating Temperature	-55 to +125	°C
$T_{STG}$	Storage Temperature	-65 to +150	°C
$V_G$	Maximum Signal Voltage to Ground	-0.5 to +7	V
$T_L$	Maximum Lead Temperature (10 seconds)	300	°C

Parameter	
Flash Data Retention	10 Years
Flash Endurance (Write/Erase Cycles)	10,000

## Normal Operating Conditions

Symbol	Parameter	Minimum	Maximum	Units
$V_{CC}$	Power Supply Voltage	+4.5	+5.5	V
$V_{IH}$	Input High Voltage	+2.2	$V_{CC} + 0.3$	V
$V_{IL}$	Input Low Voltage	-0.5	+0.8	V

## Capacitance

( $V_{IN} = 0V$ ,  $f = 1MHz$ ,  $T_C = 25^\circ C$ )

Symbol	Parameter	Maximum	Units
$C_{AD}$	$A_0 - A_{18}$ Capacitance	80	pF
$C_{OE}$	$\overline{OE}$ Capacitance	80	pF
$C_{WE1-4}$	F/S Write Enable Capacitance	30	pF
$C_{CE}$	F/S Chip Enable Capacitance	50	pF
$C_{I/O}$	I/O <sub>0</sub> – I/O <sub>31</sub> Capacitance	30	pF

This parameter is guaranteed by design but not tested

## DC Characteristics

( $V_{CC} = 5.0V$ ,  $V_{SS} = 0V$ ,  $T_C = -55^\circ C$  to  $+125^\circ C$ )

Parameter	Sym	Conditions	Min	Max	Units
Input Leakage Current	$I_{LI}$	$V_{CC} = \text{Max}$ , $V_{IN} = 0$ to $V_{CC}$		10	$\mu A$
Output Leakage Current	$I_{LO}$	$\overline{FCE} = \overline{SCE} = V_{IH}$ , $\overline{OE} = V_{IH}$ , $V_{OUT} = 0$ to $V_{CC}$		10	$\mu A$
SRAM Operating Supply Current x 32 Mode	$I_{CCx32}$	$\overline{SCE} = V_{IL}$ , $\overline{OE} = V_{IH}$ , $f = 5MHz$ , $V_{CC} = \text{Max}$ , $\overline{FCE} = V_{IH}$		550	mA
Standby Current	$I_{SB}$	$\overline{FCE} = \overline{SCE} = V_{IH}$ , $\overline{OE} = V_{IH}$ , $f = 5MHz$ , $V_{CC} = \text{Max}$		80	mA
SRAM Output Low Voltage	$V_{OL}$	$I_{OL} = 8 \text{ mA}$ , $V_{CC} = \text{Min}$ , $\overline{FCE} = V_{IH}$		0.4	V
SRAM Output High Voltage	$V_{OH}$	$I_{OH} = -4.0 \text{ mA}$ , $V_{CC} = \text{Min}$ , $\overline{FCE} = V_{IH}$	2.4		V
Flash Vcc Active Current for Read (1)	$I_{CC1}$	$\overline{FCE} = V_{IL}$ , $\overline{OE} = V_{IH}$ , $\overline{SCE} = V_{IH}$		220	mA
Flash Vcc Active Current for Program or Erase (2)	$I_{CC2}$	$\overline{FCE} = V_{IL}$ , $\overline{OE} = V_{IH}$ , $\overline{SCE} = V_{IH}$		280	mA
Flash Output Low Voltage	$V_{OL}$	$I_{OL} = 12 \text{ mA}$ , $V_{CC} = \text{Min}$ , $\overline{SCE} = V_{IH}$		0.45	V
Flash Output High Voltage	$V_{OH1}$	$I_{OH} = -2.5 \text{ mA}$ , $V_{CC} = \text{Min}$ , $\overline{SCE} = V_{IH}$	$0.85 \times V_{CC}$		V
Flash Low Vcc Lock Out Voltage	$V_{LKO}$		3.2	4.2	V

Notes: 1) The  $I_{CC}$  current listed includes both the DC operating current and the frequency dependent component (at 5MHz). The frequency component typically is less than 2mA/MHz, with  $\overline{OE}$  at  $V_{IH}$  2)  $I_{CC}$  active while Embedded Algorithm (program or erase) is in progress 3) DC test conditions:  $V_{IL} = 0.3V$ ,  $V_{IH} = V_{CC} - 0.3V$

## SRAM AC Characteristics

(V<sub>CC</sub> = 5.0V, V<sub>SS</sub> = 0V, T<sub>C</sub> = -55°C to +125°C)

### Read Cycle

Parameter	Symbol	-025		-035		Units
		Min	Max	Min	Max	
Read Cycle Time	t <sub>RC</sub>	25		35		ns
Address Access Time	t <sub>AA</sub>		25		35	ns
Chip Select Access Time	t <sub>ACE</sub>		25		35	ns
Output Hold from Address Change	t <sub>OH</sub>	0		0		ns
Output Enable to Output Valid	t <sub>OE</sub>		15		20	ns
Chip Select to Output in Low Z *	t <sub>CLZ</sub>	3		3		ns
Output Enable to Output in Low Z *	t <sub>OLZ</sub>	0		0		ns
Chip Deselect to Output in High Z *	t <sub>CHZ</sub>		12		20	ns
Output Disable to Output in High Z *	t <sub>OHZ</sub>		12		20	ns

\* Parameters guaranteed by design but not tested

### Write Cycle

Parameter	Symbol	-025		-035		Units
		Min	Max	Min	Max	
Write Cycle Time	t <sub>WC</sub>	25		35		ns
Chip Select to End of Write	t <sub>CW</sub>	20		25		ns
Address Valid to End of Write	t <sub>AW</sub>	20		25		ns
Data Valid to End of Write	t <sub>DW</sub>	15		20		ns
Write Pulse Width	t <sub>WP</sub>	20		25		ns
Address Setup Time	t <sub>AS</sub>	0		0		ns
Output Active from End of Write *	t <sub>OW</sub>	0		0		ns
Write to Output in High Z *	t <sub>WHZ</sub>		10		20	ns
Data Hold from Write Time	t <sub>DH</sub>	0		0		ns
Address Hold Time	t <sub>AH</sub>	0		0		ns

\* Parameters guaranteed by design but not tested

## SRAM Truth Table

Mode	SCE	OE	SWE	Data I/O	Power
Standby	H	X	X	High Z	Standby
Read	L	L	H	Data Out	Active
Output Disable	L	H	H	High Z	Active
Write	L	X	L	Data In	Active

# Timing Diagrams — SRAM

## Read Cycle Timing Diagrams

### Read Cycle 1 ( $\overline{SCE} = \overline{OE} = V_{IL}$ , $\overline{SWE} = V_{IH}$ )

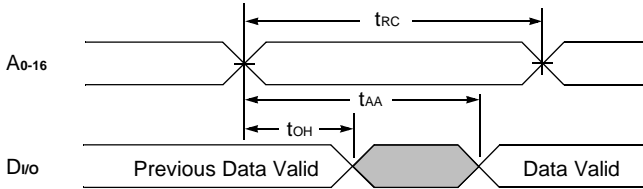

### Read Cycle 2 ( $\overline{SWE} = V_{IH}$ )

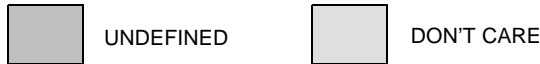
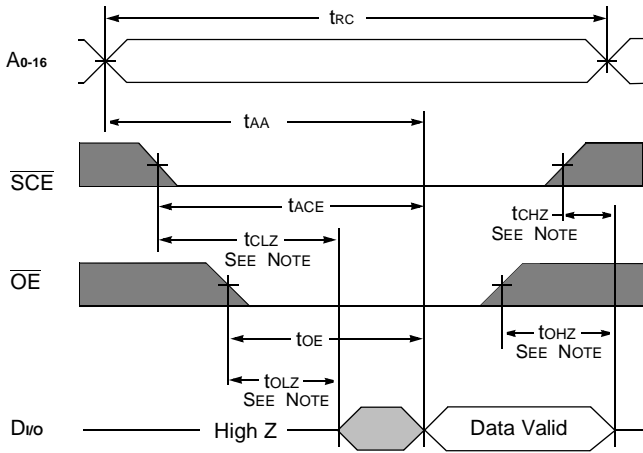

## Write Cycle Timing Diagrams

### Write Cycle ( $\overline{SWE}$ Controlled, $\overline{OE} = V_{IH}$ )

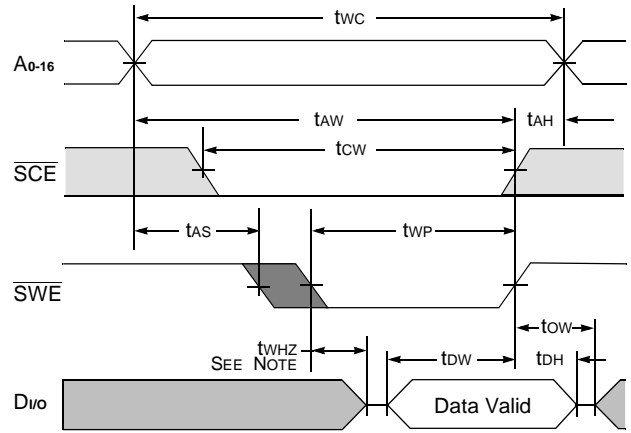

### Write Cycle ( $\overline{SCE}$ Controlled, $\overline{OE} = V_{IH}$ )

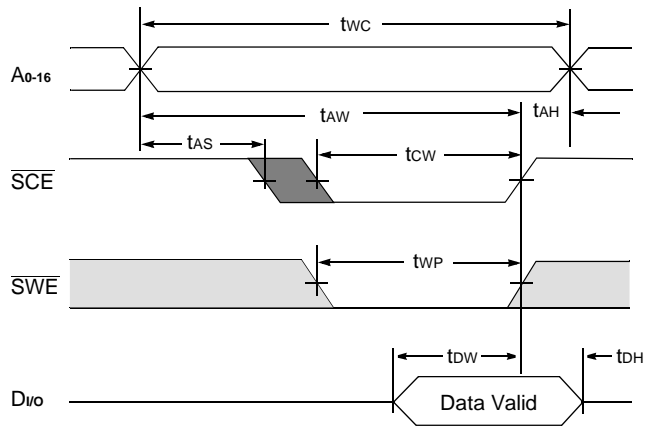

Note: Guaranteed by design, but not tested.

## AC Test Circuit

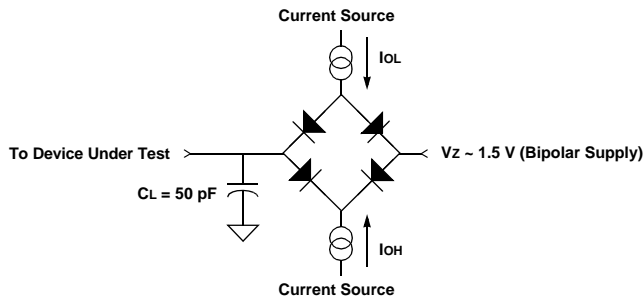

## AC Test Conditions

Parameter	Typical	Units
Input Pulse Level	0 – 3.0	V
Input Rise and Fall	5	ns
Input and Output Timing Reference Level	1.5	V

### Notes:

- 1)  $V_Z$  is programmable from -2V to +7V.
- 2)  $I_{OL}$  and  $I_{OH}$  programmable from 0 to 16 mA.
- 3) Tester Impedance  $Z_0 = 75\Omega$ .
- 4)  $V_Z$  is typically the midpoint of  $V_{OH}$  and  $V_{OL}$ .
- 5)  $I_{OL}$  and  $I_{OH}$  are adjusted to simulate a typical resistance load circuit.
- 6) ATE Tester includes jig capacitance.

## Flash AC Characteristics – Read Only Operations

(V<sub>cc</sub> = 5.0V, V<sub>ss</sub> = 0V, T<sub>c</sub> = -55°C to +125°C)

Parameter	Symbol		-60		-70		-90		Units
	JEDEC	Stand'd	Min	Max	Min	Max	Min	Max	
Read Cycle Time	t <sub>AVAV</sub>	t <sub>RC</sub>	60		70		90		ns
Address Access Time	t <sub>AVQV</sub>	t <sub>ACC</sub>		60		70		90	ns
Chip Enable Access Time	t <sub>ELQV</sub>	t <sub>CE</sub>		60		70		90	ns
Output Enable to Output Valid	t <sub>GLQV</sub>	t <sub>OE</sub>		30		35		40	ns
Chip Enable to Output High Z (1)	t <sub>EHQZ</sub>	t <sub>DF</sub>		20		20		25	ns
Output Enable High to Output High Z(1)	t <sub>GHQZ</sub>	t <sub>DF</sub>		20		20		25	ns
Output Hold from Address, CE or OE Change, Whichever is First	t <sub>AXQX</sub>	t <sub>OH</sub>	0		0		0		ns

Note 1. Guaranteed by design, but not tested

## Flash AC Characteristics – Write/Erase/Program Operations, FWE Controlled

(V<sub>cc</sub> = 5.0V, V<sub>ss</sub> = 0V, T<sub>c</sub> = -55°C to +125°C)

Parameter	Symbol		-60		-70		-90		Units
	JEDEC	Stand'd	Min	Max	Min	Max	Min	Max	
Write Cycle Time	t <sub>AVAC</sub>	t <sub>WC</sub>	60		70		90		ns
Chip Enable Setup Time	t <sub>ELWL</sub>	t <sub>CE</sub>	0		0		0		ns
Write Enable Pulse Width	t <sub>WLWH</sub>	t <sub>WP</sub>	30		35		45		ns
Address Setup Time	t <sub>AVWL</sub>	t <sub>AS</sub>	0		0		0		ns
Data Setup Time	t <sub>DVWH</sub>	t <sub>DS</sub>	30		30		45		ns
Data Hold Time	t <sub>WHDX</sub>	t <sub>DH</sub>	0		0		0		ns
Address Hold Time	t <sub>WLAX</sub>	t <sub>AH</sub>	45		45		45		ns
Chip Enable Hold Time	t <sub>WHEH</sub>	t <sub>CH</sub>	0		0		0		ns
Write Enable Pulse Width High	t <sub>WHWL</sub>	t <sub>WPH</sub>	20		20		20		ns
Duration of Byte Programming Operation	t <sub>WHWH1</sub>		14	TYP	14	TYP	14	TYP	μs
Sector Erase Time	t <sub>WHWH2</sub>			60		60		60	Sec
Chip Erase Time	t <sub>WHWH3</sub>			120		120		120	Sec
Read Recovery Time before Write	t <sub>GHWL</sub>		0		0		0		μs
V <sub>cc</sub> Setup Time		t <sub>VCE</sub>	50		50		50		μs
Output Enable Setup Time		t <sub>OES</sub>		12.5		12.5		12.5	Sec
Output Enable Hold Time <sup>1</sup>		t <sub>OEH</sub>	10		10		10		ns

Note: 1. For Toggle and Data Polling.

## Flash AC Characteristics – Write/Erase/Program Operations, FCE Controlled

(V<sub>cc</sub> = 5.0V, V<sub>ss</sub> = 0V, T<sub>c</sub> = -55°C to +125°C)

Parameter	Symbol		-60		-70		-90		Units
	JEDEC	Stand'd	Min	Max	Min	Max	Min	Max	
Write Cycle Time	t <sub>AVAC</sub>	t <sub>WC</sub>	60		70		90		ns
Write Enable Setup Time	t <sub>WLEL</sub>	t <sub>WS</sub>	0		0		0		ns
Chip Enable Pulse Width	t <sub>ELEH</sub>	t <sub>CP</sub>	35		35		50		ns
Address Setup Time	t <sub>AVEL</sub>	t <sub>AS</sub>	0		0		0		ns
Data Setup Time	t <sub>DVEH</sub>	t <sub>DS</sub>	30		30		50		ns
Data Hold Time	t <sub>EHDX</sub>	t <sub>DH</sub>	0		0		0		ns
Address Hold Time	t <sub>ELAX</sub>	t <sub>AH</sub>	45		45		50		ns
Write Enable Hold from Write Enable High	t <sub>EHWH</sub>	t <sub>WH</sub>	0		0		0		ns
Chip Enable Pulse Width High	t <sub>EHEL</sub>	t <sub>CPH</sub>	20		20		20		ns
Duration of Byte Programming	t <sub>WHWH1</sub>		14	TYP	14	TYP	14	TYP	μs
Sector Erase Time	t <sub>WHWH2</sub>			60		60		60	Sec
Chip Erase Time	t <sub>WHWH3</sub>			120		120		120	Sec
Read Recovery Time	t <sub>GHEL</sub>		0		0		0		ns
Chip Programming Time				12.5		12.5		12.5	Sec

# AC Waveforms for Flash Memory Read Operations

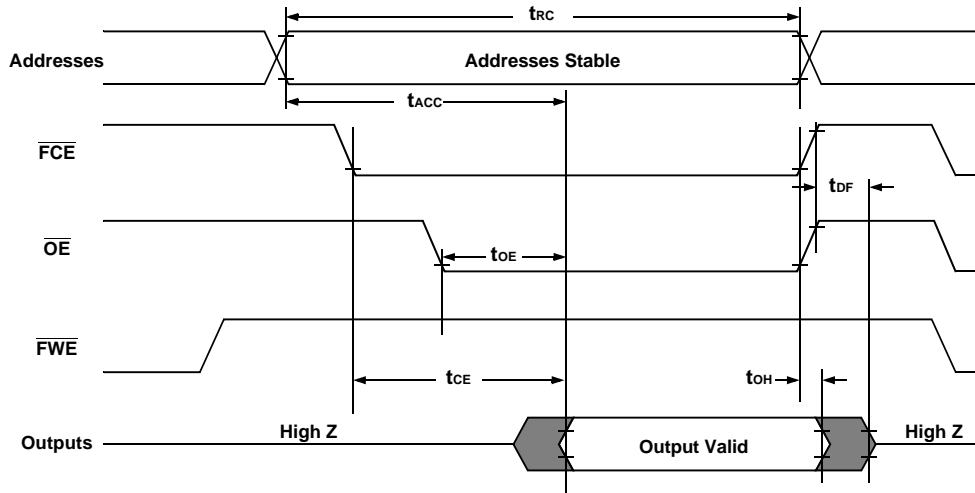

# Write/Erase/Program Operation for Flash Memory, $\overline{FWE}$ Controlled

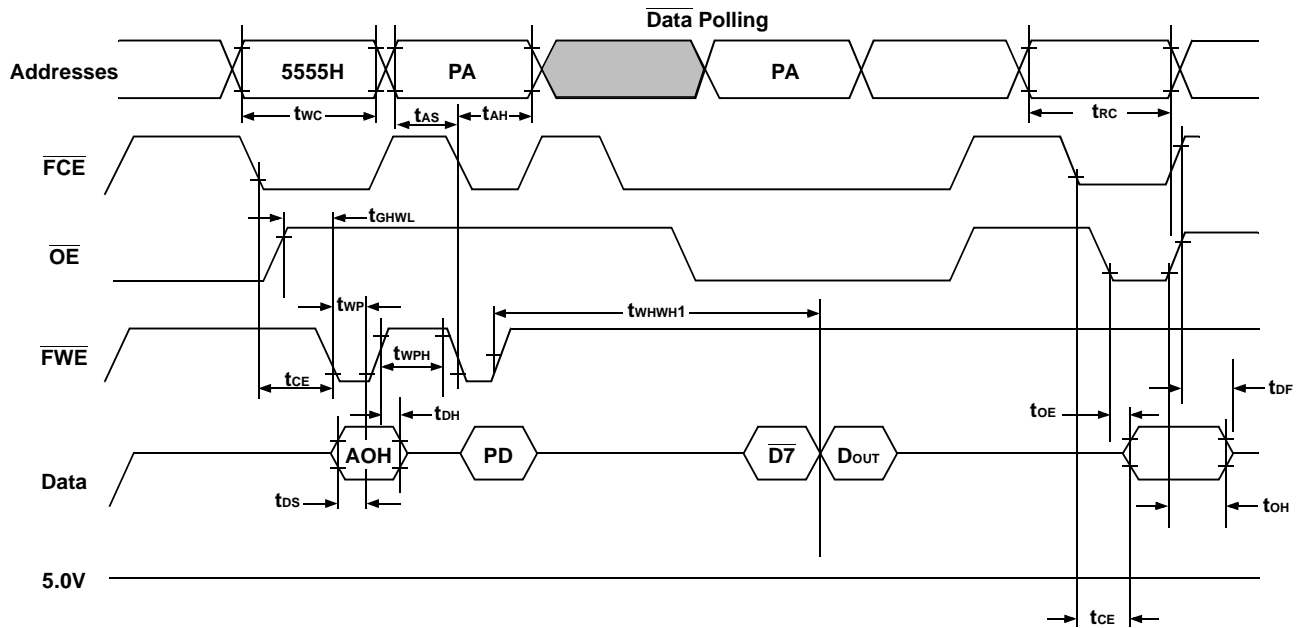

- Notes:**
1. PA is the address of the memory location to be programmed.
  2. PD is the data to be programmed at byte address.
  3. D7 is the Output of the complement of the data written to the device.
  4. DOUT is the output of the data written to the device.
  5. Figure indicates last two bus cycles of four bus cycle sequence.

## AC Waveforms Chip/Sector Erase Operations for Flash Memory

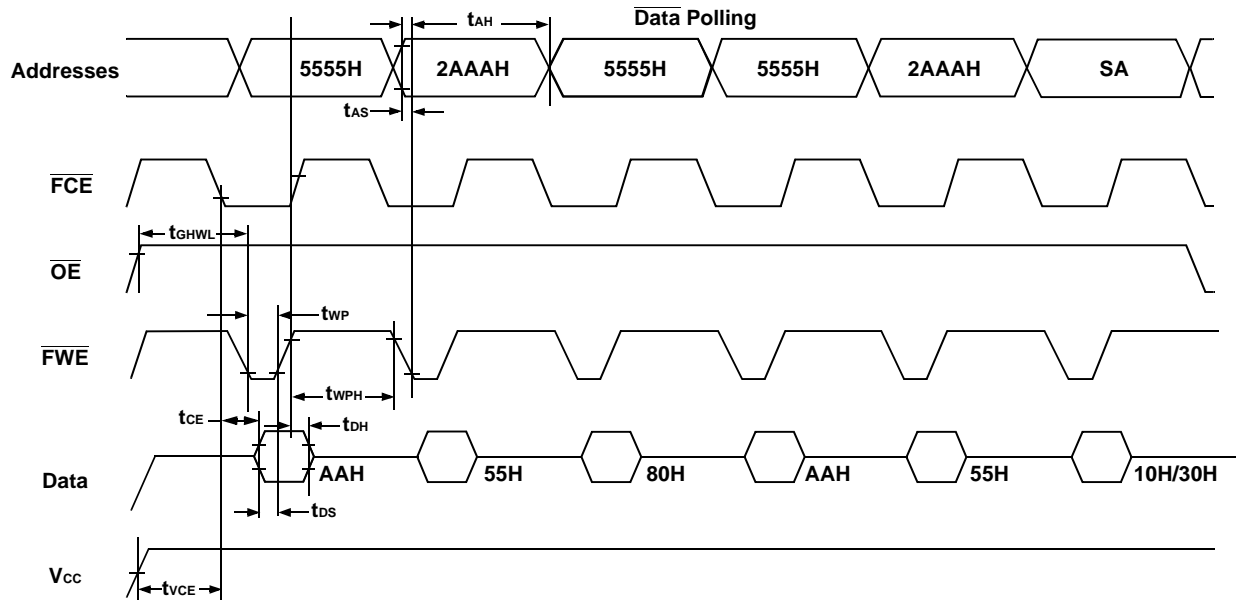

**Notes:**  
1. SA is the sector address for sector erase.

## AC Waveforms for Data Polling During Embedded Algorithm Operations for Flash Memory

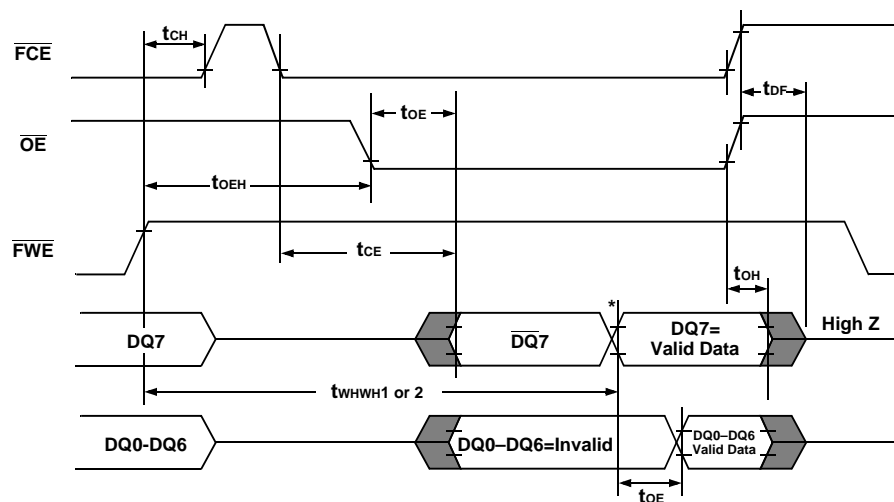

\* DQ7=Valid Data (The device has completed the Embedded operation).

# Write/Erase/Program Operation for Flash Memory, $\overline{FCE}$ Controlled

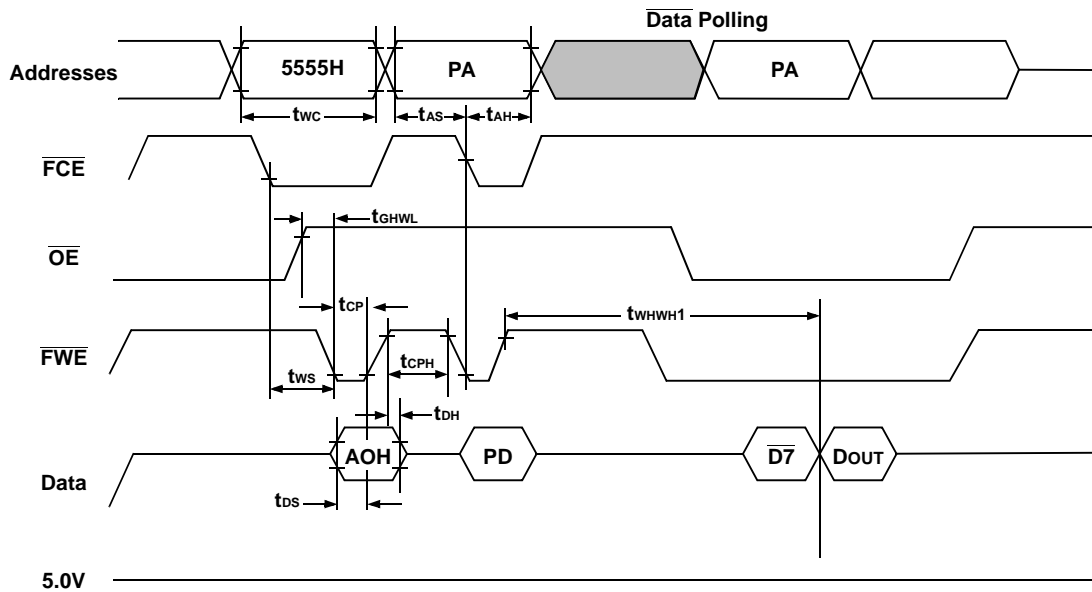

**Notes:**

1. PA is the address of the memory location to be programmed.
2. PD is the data to be programmed at byte address.
3.  $\overline{D7}$  is the Output of the complement of the data written to the device.
4. DOUT is the output of the data written to the device.
5. Figure indicates last two bus cycles of four bus cycle sequence.



## Pin Numbers & Functions

66 Pins — PGA-Type							
Pin #	Function	Pin #	Function	Pin #	Function	Pin #	Function
1	I/O8	18	A15	35	I/O25	52	$\overline{FWE}_3$
2	I/O9	19	V <sub>CC</sub>	36	I/O26	53	$\overline{SWE}_3$
3	I/O10	20	$\overline{FCE}$	37	A7	54	GND
4	A14	21	$\overline{SCE}$	38	A12	55	I/O19
5	A16	22	I/O3	39	$\overline{SWE}_1$	56	I/O31
6	A11	23	I/O15	40	A13	57	I/O30
7	A0	24	I/O14	41	A8	58	I/O29
8	NC	25	I/O13	42	I/O16	59	I/O28
9	I/O0	26	I/O12	43	I/O17	60	A1
10	I/O1	27	$\overline{OE}$	44	I/O18	61	A2
11	I/O2	28	NC	45	V <sub>CC</sub>	62	A3
12	$\overline{FWE}_2$	29	$\overline{FWE}_1$	46	$\overline{SWE}_4$	63	I/O23
13	$\overline{SCE}_2$	30	I/O7	47	$\overline{FWE}_4$	64	I/O22
14	GND	31	I/O6	48	I/O27	65	I/O21
15	I/O11	32	I/O5	49	A4	66	I/O20
16	A10	33	I/O4	50	A5		
17	A9	34	I/O24	51	A6		

"P3" — 1.08" SQ PGA Type Package Standard (without shoulders)

"P7" — 1.08" SQ PGA Type Package (with shoulders on Pins 1, 11, 56 & 66)

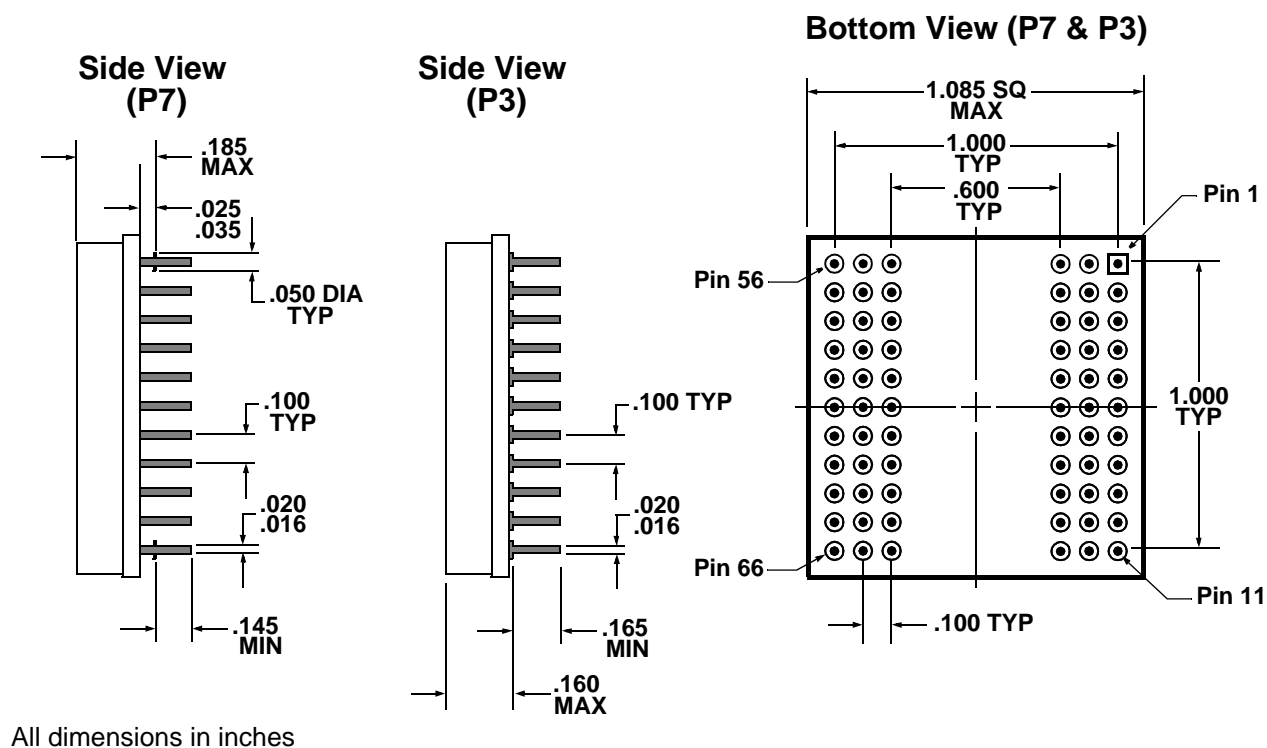



### Ordering Information

Model Number	DESC Part Number	Speed	Package
ACT-SF128K32N-26P1X	TBD	25(S) / 60(F) ns	1.08"sq PGA-Type
ACT-SF128K32N-37P1X	TBD	35(S) / 70(F) ns	1.08"sq PGA-Type
ACT-SF128K32N-39P1X	TBD	35(S) / 90(F) ns	1.08"sq PGA-Type

Note: (S) = Speed for SRAM, (F) = Speed for FLASH

### Part Number Breakdown

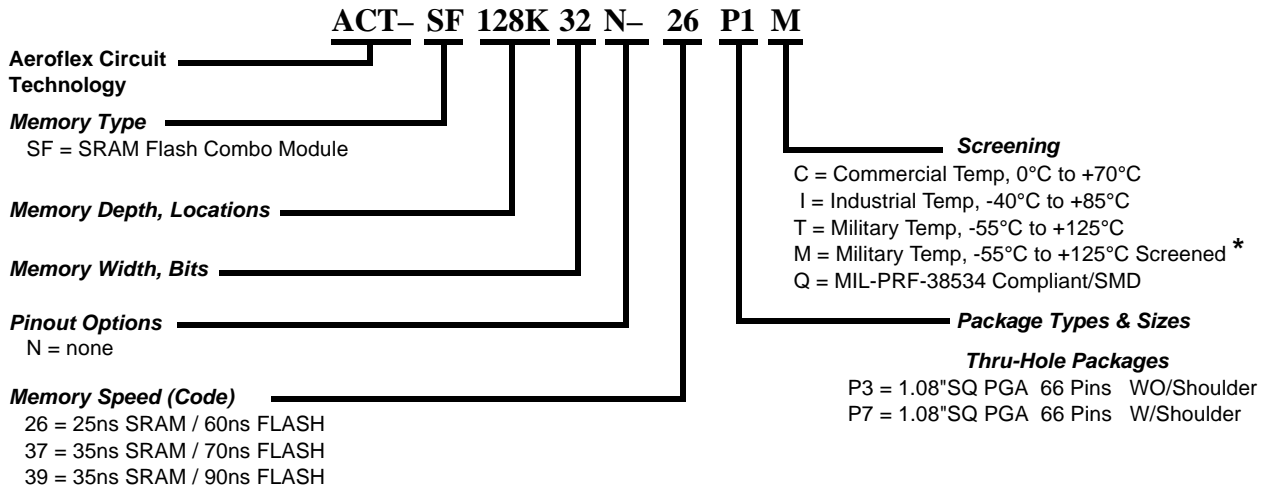

\* Screened to the individual test methods of MIL-STD-883

Specifications subject to change without notice.

<b>Aeroflex Circuit Technology</b> <b>35 South Service Road</b> <b>Plainview New York 11830</b>	<b>Telephone: (516) 694-6700</b> <b>FAX: (516) 694-6715</b> <b>Toll Free Inquiries: 1-(800) 843-1553</b>
---	--