

ACT-SF512K32 High Speed 512Kx32 SRAM / 512Kx32 Flash Multichip Module



FEATURES

- 4 – 512K x 8 SRAMs & 4 – 512K x 8 Flash Die in One MCM
- Access Times of 25ns, 35ns (SRAM) and 60ns, 70ns, 90ns (Flash)
- Organized as 512K x 32 of SRAM and 512K x 32 of Flash Memory with Common Data Bus
- Low Power CMOS
- Input and Output TTL Compatible Design
- MIL-PRF-38534 Compliant MCMs Available
- Decoupling Capacitors and Multiple Grounds for Low Noise
- Commercial, Industrial and Military Temperature Ranges
- Industry Standard Pinouts
- TTL Compatible Inputs and Outputs
- Packaging – Hermetic Ceramic
 - 66-Lead, PGA-Type, 1.385"SQ x 0.245" max, Aeroflex code# "P1,P5 with/without shoulders"
 - 68-Lead, Dual-Cavity CQFP(F2), 0.88"SQ x .20" max (.18 max thickness available, contact factory for details) (*Drops into the 68 Lead JEDEC .99"SQ CQFJ footprint*)

FLASH MEMORY FEATURES

- Sector Architecture (Each Die)
 - 8 Equal Sectors of 64K bytes each
 - Any combination of sectors can be erased with one command sequence
- +5V Programming, +5V Supply
- Embedded Erase and Program Algorithms
- Hardware and Software Write Protection
- Page Program Operation and Internal Program Control Time.
- 10,000 Erase/Program Cycles



Block Diagram – PGA Type Package(P1 & P5) & CQFP(F2)

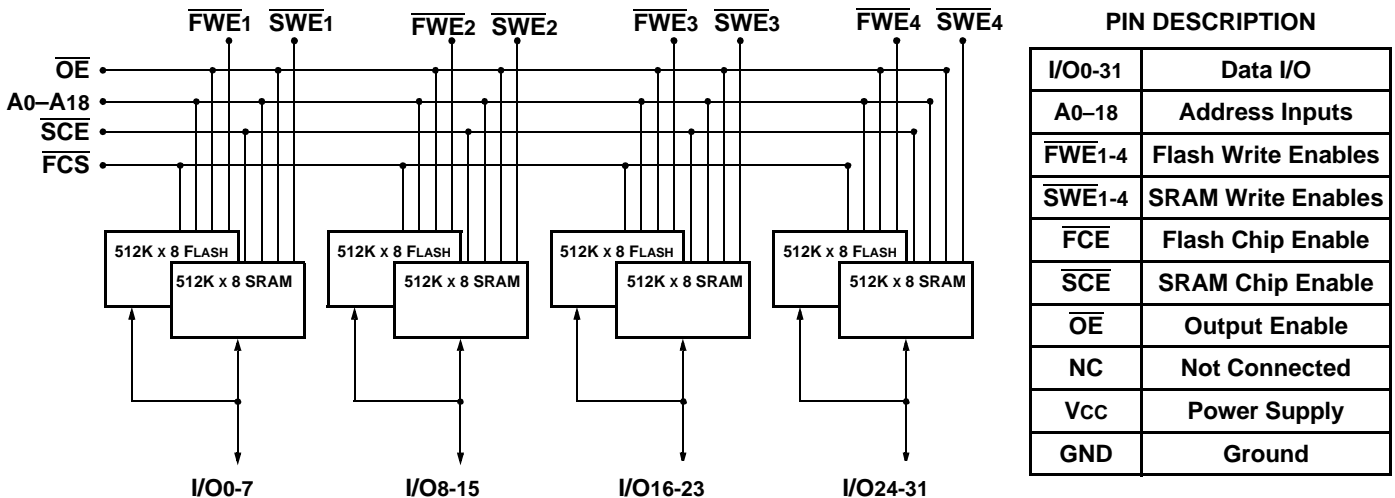

Absolute Maximum Ratings

Symbol	Rating	Range	Units
T_C	Operating Temperature	-55 to +125	°C
T_{STG}	Storage Temperature	-65 to +150	°C
V_G	Maximum Signal Voltage to Ground	-0.5 to +7	V
T_L	Maximum Lead Temperature (10 seconds)	300	°C

Parameter	
Flash Data Retention	10 Years
Flash Endurance (Write/Erase Cycles)	10,000

Normal Operating Conditions

Symbol	Parameter	Minimum	Maximum	Units
V_{CC}	Power Supply Voltage	+4.5	+5.5	V
V_{IH}	Input High Voltage	+2.2	$V_{CC} + 0.3$	V
V_{IL}	Input Low Voltage	-0.5	+0.8	V

Capacitance

($V_{IN} = 0V$, $f = 1MHz$, $T_C = 25^\circ C$)

Symbol	Parameter	Maximum	Units
C_{AD}	$A_0 - A_{18}$ Capacitance	80	pF
C_{OE}	\overline{OE} Capacitance	80	pF
C_{WE1-4}	F/S Write Enable Capacitance	30	pF
C_{CE}	F/S Chip Enable Capacitance	50	pF
$C_{I/O}$	I/O ₀ – I/O ₃₁ Capacitance	30	pF

This parameter is guaranteed by design but not tested

DC Characteristics

($V_{CC} = 5.0V$, $V_{SS} = 0V$, $T_C = -55^\circ C$ to $+125^\circ C$)

Parameter	Sym	Conditions	Min	Max	Units
Input Leakage Current	I_{LI}	$V_{CC} = Max$, $V_{IN} = 0$ to V_{CC}		10	μA
Output Leakage Current	I_{LO}	$\overline{FCE} = \overline{SCE} = V_{IH}$, $\overline{OE} = V_{IH}$, $V_{OUT} = 0$ to V_{CC}		10	μA
SRAM Operating Supply Current x 32 Mode	I_{CCx32}	$\overline{SCE} = V_{IL}$, $\overline{OE} = V_{IH}$, $f = 5MHz$, $V_{CC} = Max$, $\overline{FCE} = V_{IH}$		550	mA
Standby Current	I_{SB}	$\overline{FCE} = \overline{SCE} = V_{IH}$, $\overline{OE} = V_{IH}$, $f = 5MHz$, $V_{CC} = Max$		80	mA
SRAM Output Low Voltage	V_{OL}	$I_{OL} = 8 mA$, $V_{CC} = Min$, $\overline{FCE} = V_{IH}$		0.4	V
SRAM Output High Voltage	V_{OH}	$I_{OH} = -4.0 mA$, $V_{CC} = Min$, $\overline{FCE} = V_{IH}$	2.4		V
Flash Vcc Active Current for Read (1)	I_{CC1}	$\overline{FCE} = V_{IL}$, $\overline{OE} = V_{IH}$, $\overline{SCE} = V_{IH}$		260	mA
Flash Vcc Active Current for Program or Erase (2)	I_{CC2}	$\overline{FCE} = V_{IL}$, $\overline{OE} = V_{IH}$, $\overline{SCE} = V_{IH}$		300	mA
Flash Output Low Voltage	V_{OL}	$I_{OL} = 12 mA$, $V_{CC} = Min$, $\overline{SCE} = V_{IH}$		0.45	V
Flash Output High Voltage	V_{OH1}	$I_{OH} = -2.5 mA$, $V_{CC} = Min$, $\overline{SCE} = V_{IH}$	$0.85 \times V_{CC}$		V
Flash Low Vcc Lock Out Voltage	V_{LKO}		3.2	4.2	V

Notes: 1) The I_{CC} current listed includes both the DC operating current and the frequency dependent component (at 5MHz). The frequency component typically is less than 2mA/MHz, with \overline{OE} at V_{IH} 2) I_{CC} active while Embedded Algorithm (program or erase) is in progress 3) DC test conditions: $V_{IL} = 0.3V$, $V_{IH} = V_{CC} - 0.3V$

SRAM AC Characteristics

(V_{CC} = 5.0V, V_{SS} = 0V, T_c = -55°C to +125°C)

Read Cycle

Parameter	Symbol	-025		-035		Units
		Min	Max	Min	Max	
Read Cycle Time	t _{RC}	25		35		ns
Address Access Time	t _{AA}		25		35	ns
Chip Select Access Time	t _{ACE}		25		35	ns
Output Hold from Address Change	t _{OH}	0		0		ns
Output Enable to Output Valid	t _{OE}		12		25	ns
Chip Select to Output in Low Z *	t _{CLZ}	2		4		ns
Output Enable to Output in Low Z *	t _{OLZ}	0		0		ns
Chip Deselect to Output in High Z *	t _{CHZ}		12		15	ns
Output Disable to Output in High Z *	t _{OHZ}		12		15	ns

* Parameters guaranteed by design but not tested

Write Cycle

Parameter	Symbol	-025		-035		Units
		Min	Max	Min	Max	
Write Cycle Time	t _{WC}	25		35		ns
Chip Select to End of Write	t _{CW}	17		25		ns
Address Valid to End of Write	t _{AW}	17		25		ns
Data Valid to End of Write	t _{DW}	13		20		ns
Write Pulse Width	t _{WP}	17		25		ns
Address Setup Time	t _{AS}	2		2		ns
Output Active from End of Write *	t _{OW}	4		4		ns
Write to Output in High Z *	t _{WHZ}		13		15	ns
Data Hold from Write Time	t _{DH}	0		0		ns
Address Hold Time	t _{AH}	0		0		ns

* Parameters guaranteed by design but not tested

Truth Table

Mode	\overline{SCE}	\overline{OE}	\overline{SWE}	Data I/O	Power
Standby	H	X	X	High Z	Standby
Read	L	L	H	Data Out	Active
Output Disable	L	H	H	High Z	Active
Write	L	X	L	Data In	Active

Timing Diagrams — SRAM

Read Cycle Timing Diagrams

Read Cycle 1 ($\overline{SCE} = \overline{OE} = V_{IL}$, $\overline{SWE} = V_{IH}$)

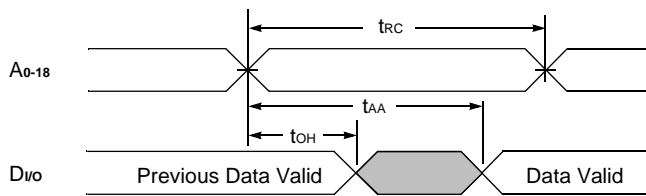

Read Cycle 2 ($\overline{SWE} = V_{IH}$)

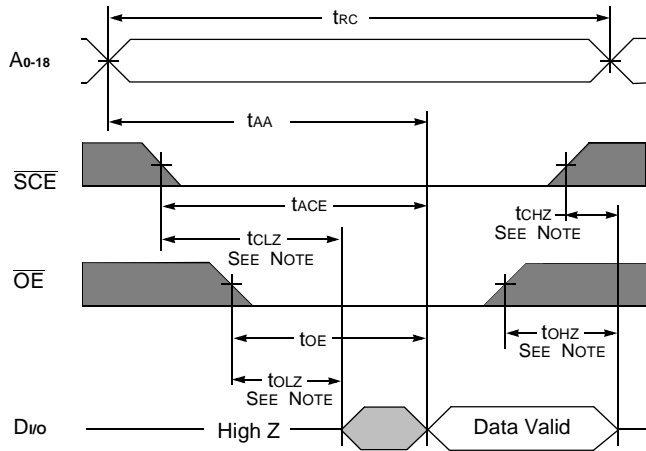

Write Cycle Timing Diagrams

Write Cycle (\overline{SWE} Controlled, $\overline{OE} = V_{IH}$)

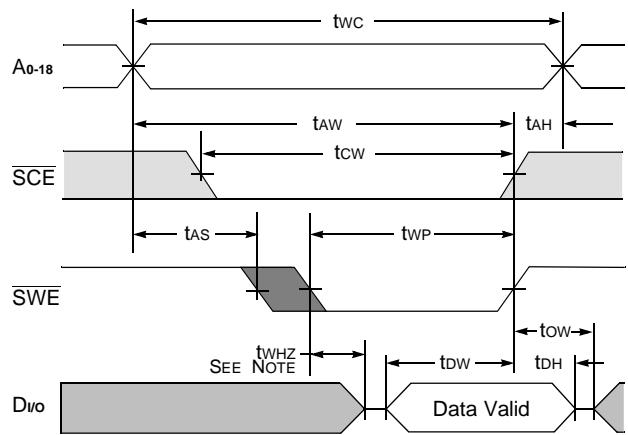

Write Cycle (\overline{SCE} Controlled, $\overline{OE} = V_{IH}$)

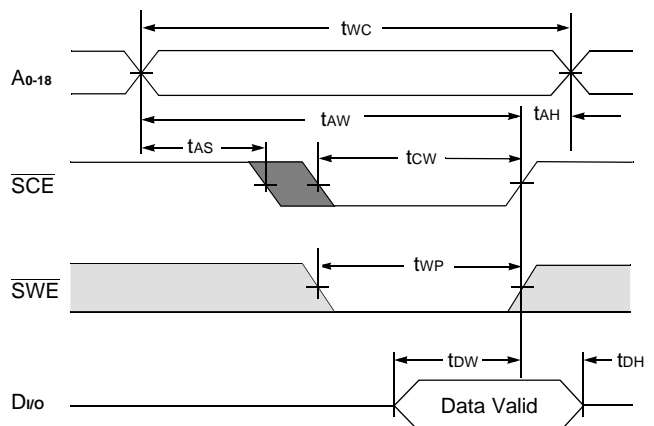

Note: Guaranteed by design, but not tested.

AC Test Circuit

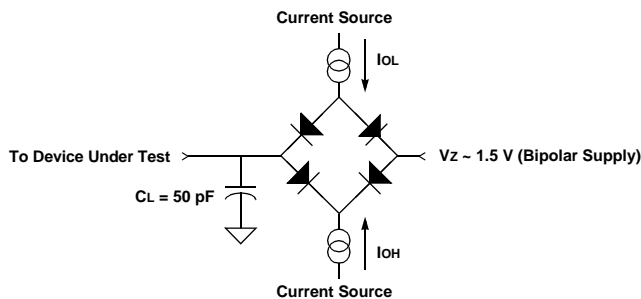

AC Test Conditions

Parameter	Typical	Units
Input Pulse Level	0 – 3.0	V
Input Rise and Fall	5	ns
Input and Output Timing Reference Level	1.5	V

Notes:

- 1) V_Z is programmable from -2V to +7V. 2) I_{OL} and I_{OH} programmable from 0 to 16 mA. 3) Tester Impedance $Z_O = 75\Omega$. 4) V_Z is typically the midpoint of V_{OH} and V_{OL} . 5) I_{OL} and I_{OH} are adjusted to simulate a typical resistance load circuit. 6) ATE Tester includes jig capacitance.

Flash AC Characteristics – Read Only Operations

(V_{cc} = 5.0V, V_{ss} = 0V, T_c = -55°C to +125°C)

Parameter	Symbol		-60		-70		-90		Units
	JEDEC	Stand'd	Min	Max	Min	Max	Min	Max	
Read Cycle Time	t _{AVAV}	t _{RC}	60		70		90		ns
Address Access Time	t _{AVQV}	t _{ACC}		60		70		90	ns
Chip Enable Access Time	t _{ELQV}	t _{CE}		60		70		90	ns
Output Enable to Output Valid	t _{GLQV}	t _{OE}		30		35		35	ns
Chip Enable to Output High Z (1)	t _{EHQZ}	t _{DF}		20		20		20	ns
Output Enable High to Output High Z(1)	t _{GHQZ}	t _{DF}		20		20		20	ns
Output Hold from Address, \overline{CE} or \overline{OE} Change, Whichever is First	t _{AXQX}	t _{OH}	0		0		0		ns

Note 1. Guaranteed by design, but not tested

Flash AC Characteristics – Write / Erase / Program Operations, \overline{FWE} Controlled

(V_{cc} = 5.0V, V_{ss} = 0V, T_c = -55°C to +125°C)

Parameter	Symbol		-60		-70		-90		Units
	JEDEC	Stand'd	Min	Max	Min	Max	Min	Max	
Write Cycle Time	t _{AVAC}	t _{WC}	60		70		90		ns
Chip Enable Setup Time	t _{ELWL}	t _{CE}	0		0		0		ns
Write Enable Pulse Width	t _{WLWH}	t _{WP}	40		45		45		ns
Address Setup Time	t _{AVWL}	t _{AS}	0		0		0		ns
Data Setup Time	t _{DVWH}	t _{DS}	40		45		45		ns
Data Hold Time	t _{WHDX}	t _{DH}	0		0		0		ns
Address Hold Time	t _{WLAX}	t _{AH}	45		45		45		ns
Write Enable Pulse Width High	t _{WHWL}	t _{WPH}	20		20		20		ns
Duration of Byte Programming Operation	t _{WHWH1}		14	TYP	14	TYP	14	TYP	μs
Sector Erase Time	t _{WHWH2}			30		30		30	Sec
Read Recovery Time before Write	t _{GHWL}		0		0		0		μs
V _{cc} Setup Time		t _{VCE}		50		50		50	μs
Chip Programming Time				50		50		50	Sec
Chip Enable Hold Time		t _{OE¹}		10		10		10	ns
Chip Erase Time	t _{WHWH3}			120		120		120	Sec

1. Toggle and Data Polling only.

Flash AC Characteristics – Write / Erase / Program Operations, \overline{FCE} Controlled

(V_{cc} = 5.0V, V_{ss} = 0V, T_c = -55°C to +125°C)

Parameter	Symbol		-60		-70		-90		Units
	JEDEC	Stand'd	Min	Max	Min	Max	Min	Max	
Write Cycle Time	t _{AVAC}	t _{WC}	60		70		90		ns
Write Enable Setup Time	t _{WLEL}	t _{WS}	0		0		0		ns
Chip Enable Pulse Width	t _{LELH}	t _{CP}	40		45		45		ns
Address Setup Time	t _{AVEL}	t _{AS}	0		0		0		ns
Data Setup Time	t _{DVEH}	t _{DS}	40		45		45		ns
Data Hold Time	t _{EHDX}	t _{DH}	0		0		0		ns
Address Hold Time	t _{ELAX}	t _{AH}	45		45		45		ns
Chip Enable Pulse Width High	t _{EHEL}	t _{CPH}	20		20		20		ns
Duration of Byte Programming	t _{WHWH1}		14	TYP	14	TYP	14	TYP	μs
Sector Erase Time	t _{WHWH2}			30		30		30	Sec
Read Recovery Time	t _{GHEL}		0		0		0		ns
Chip Programming Time				50		50		50	Sec
Chip Erase Time	t _{WHWH3}			120		120		120	Sec

AC Waveforms for Flash Memory Read Operations

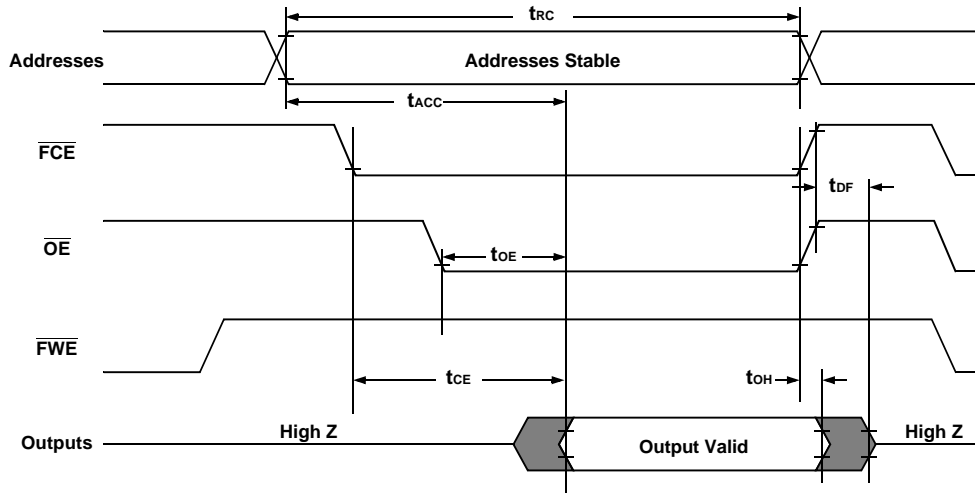

Write/Erase/Program Operation for Flash Memory, \overline{FWE} Controlled

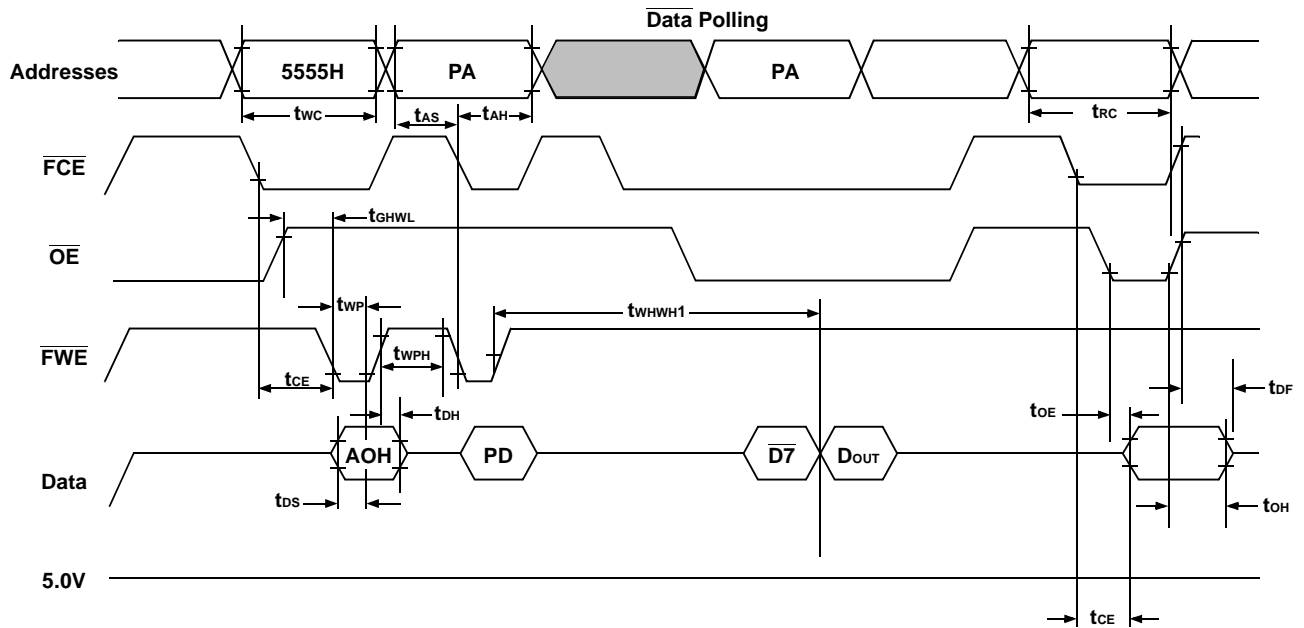

- Notes:**
1. PA is the address of the memory location to be programmed.
 2. PD is the data to be programmed at byte address.
 3. D7 is the Output of the complement of the data written to the device.
 4. Dout is the output of the data written to the device.
 5. Figure indicates last two bus cycles of four bus cycle sequence.

AC Waveforms Chip/Sector Erase Operations for Flash Memory

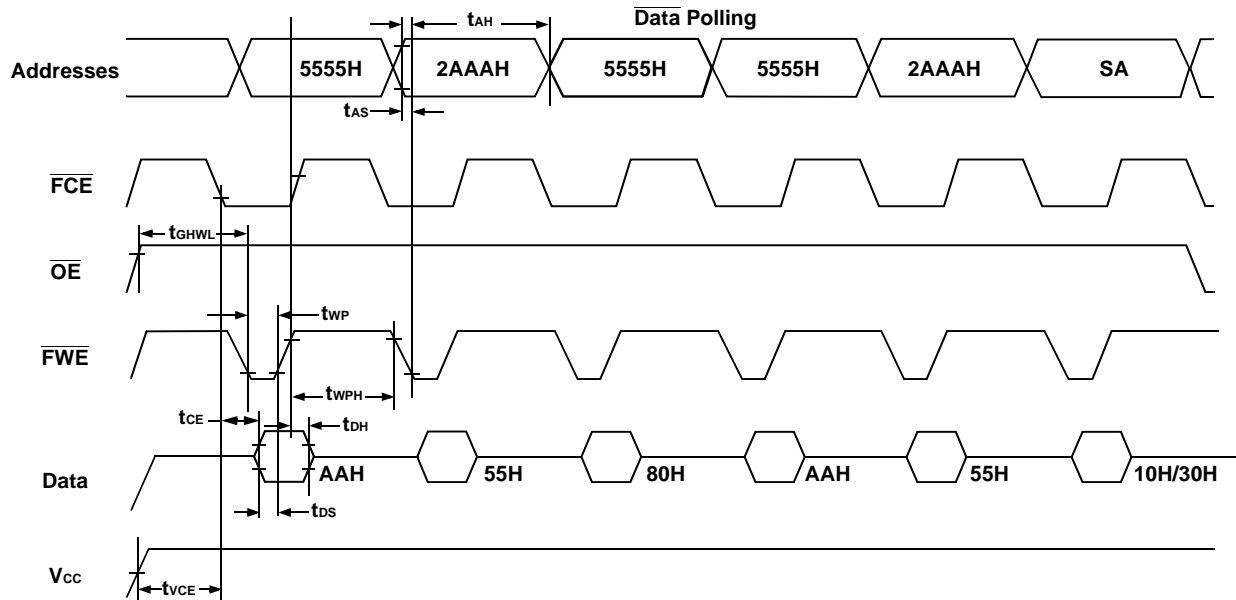

- Notes:**
 1. SA is the sector address for sector erase.

AC Waveforms for Data Polling During Embedded Algorithm Operations for Flash Memory

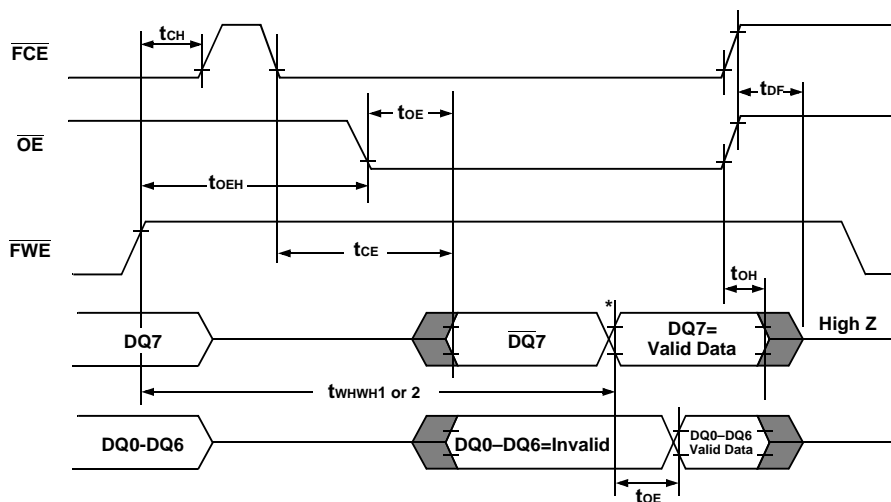

* DQ7=Valid Data (The device has completed the Embedded operation).

Write/Erase/Program Operation for Flash Memory, \overline{FCE} Controlled

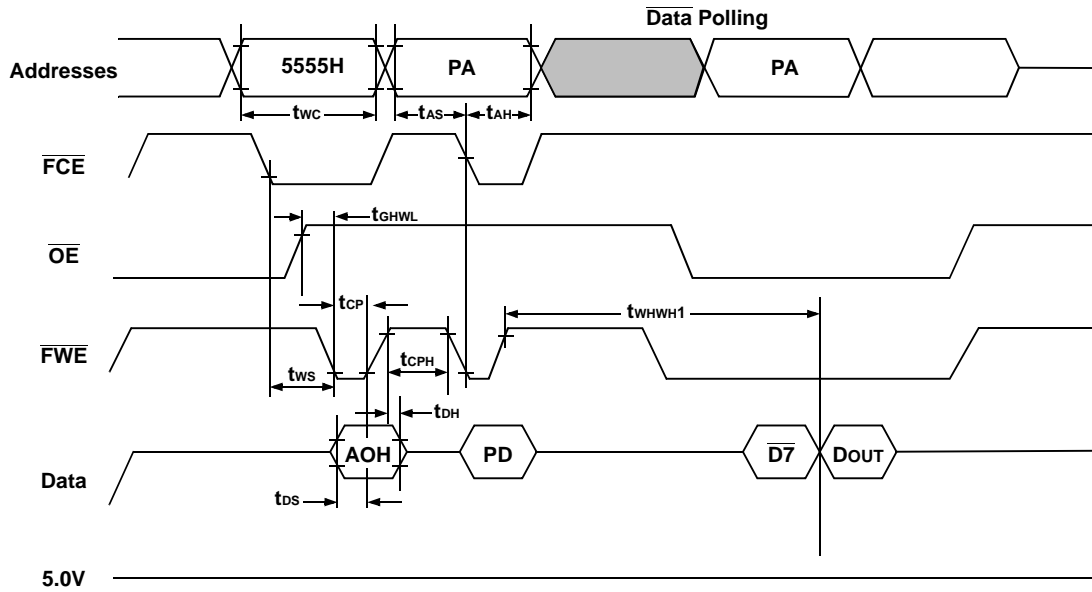

Notes:

1. PA is the address of the memory location to be programmed.
2. PD is the data to be programmed at byte address.
3. $\overline{D7}$ is the Output of the complement of the data written to the device.
4. DOUT is the output of the data written to the device.
5. Figure indicates last two bus cycles of four bus cycle sequence.

Pin Numbers & Functions

66 Pins — PGA-Type							
Pin #	Function	Pin #	Function	Pin #	Function	Pin #	Function
1	I/O ₈	18	A ₁₅	35	I/O ₂₅	52	$\overline{\text{FWE}}_3$
2	I/O ₉	19	V _{cc}	36	I/O ₂₆	53	$\overline{\text{SWE}}_3$
3	I/O ₁₀	20	$\overline{\text{FCE}}$	37	A ₇	54	GND
4	A ₁₄	21	$\overline{\text{SCE}}$	38	A ₁₂	55	I/O ₁₉
5	A ₁₆	22	I/O ₃	39	$\overline{\text{SWE}}_1$	56	I/O ₃₁
6	A ₁₁	23	I/O ₁₅	40	A ₁₃	57	I/O ₃₀
7	A ₀	24	I/O ₁₄	41	A ₈	58	I/O ₂₉
8	A ₁₈	25	I/O ₁₃	42	I/O ₁₆	59	I/O ₂₈
9	I/O ₀	26	I/O ₁₂	43	I/O ₁₇	60	A ₁
10	I/O ₁	27	$\overline{\text{OE}}$	44	I/O ₁₈	61	A ₂
11	I/O ₂	28	A ₁₇	45	V _{cc}	62	A ₃
12	$\overline{\text{FWE}}_2$	29	$\overline{\text{FWE}}_1$	46	$\overline{\text{SWE}}_4$	63	I/O ₂₃
13	$\overline{\text{SWE}}_2$	30	I/O ₇	47	$\overline{\text{FWE}}_4$	64	I/O ₂₂
14	GND	31	I/O ₆	48	I/O ₂₇	65	I/O ₂₁
15	I/O ₁₁	32	I/O ₅	49	A ₄	66	I/O ₂₀
16	A ₁₀	33	I/O ₄	50	A ₅		
17	A ₉	34	I/O ₂₄	51	A ₆		

"P1" — 1.385" SQ PGA Type Package Standard (with shoulders on Pins 1, 11, 56 & 66)

"P5" — 1.385" SQ PGA Type Special Order Package (without shoulders)

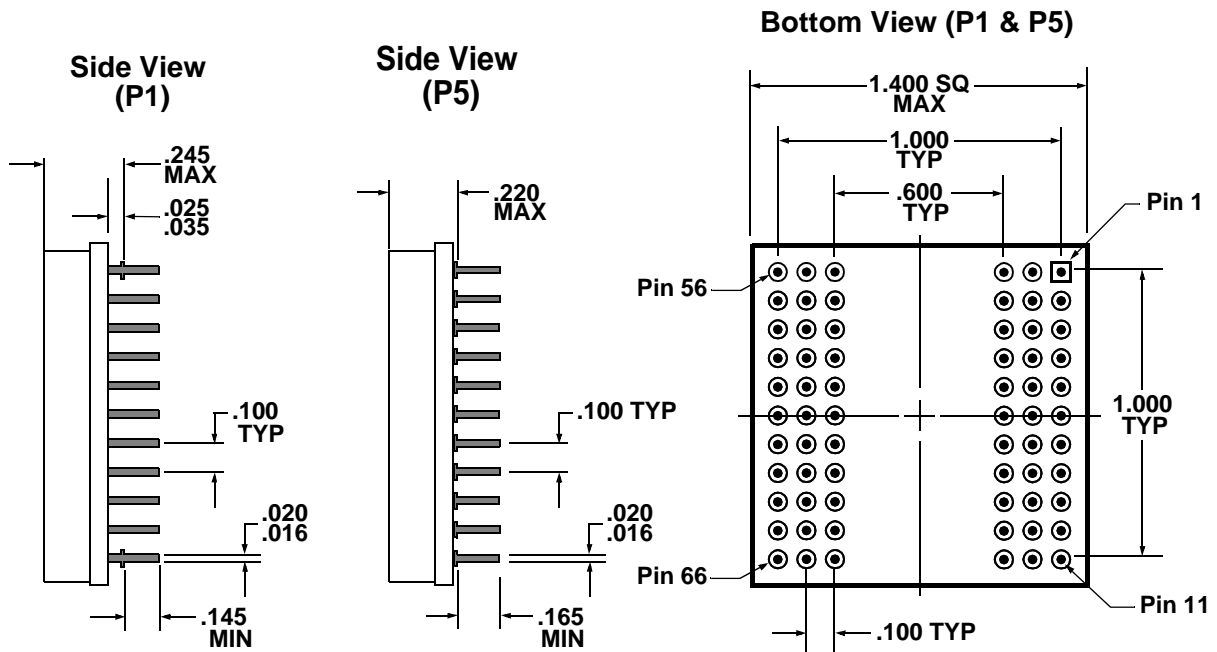

All dimensions in inches

Pin Numbers & Functions

68 Pins — Dual-Cavity CQFP							
Pin #	Function	Pin #	Function	Pin #	Function	Pin #	Function
1	GND	18	GND	35	\overline{OE}	52	GND
2	\overline{SWE}_3	19	I/O ₈	36	\overline{SWE}_2	53	FI/O ₂₃
3	A ₅	20	I/O ₉	37	A ₁₇	54	FI/O ₂₂
4	A ₄	21	I/O ₁₀	38	\overline{FWE}_2	55	FI/O ₂₁
5	A ₃	22	I/O ₁₁	39	\overline{FWE}_3	56	FI/O ₂₀
6	A ₂	23	I/O ₁₂	40	\overline{FWE}_4	57	FI/O ₁₉
7	A ₁	24	I/O ₁₃	41	A ₁₈	58	FI/O ₁₈
8	A ₀	25	I/O ₁₄	42	\overline{SCE}	59	FI/O ₁₇
9	NC	26	I/O ₁₅	43	\overline{SWE}_1	60	FI/O ₁₆
10	I/O ₀	27	V _{CC}	44	FI/O ₃₁	61	V _{CC}
11	I/O ₁	28	A ₁₁	45	FI/O ₃₀	62	A ₁₀
12	I/O ₂	29	A ₁₂	46	FI/O ₂₉	63	A ₉
13	I/O ₃	30	A ₁₃	47	FI/O ₂₈	64	A ₈
14	I/O ₄	31	A ₁₄	48	FI/O ₂₇	65	A ₇
15	I/O ₅	32	A ₁₅	49	FI/O ₂₆	66	A ₆
16	I/O ₆	33	A ₁₆	50	FI/O ₂₅	67	\overline{FWE}_1
17	I/O ₇	34	\overline{FCE}	51	FI/O ₂₄	68	\overline{SWE}_4

Package Outline — Dual-Cavity CQFP "F2"

Top View

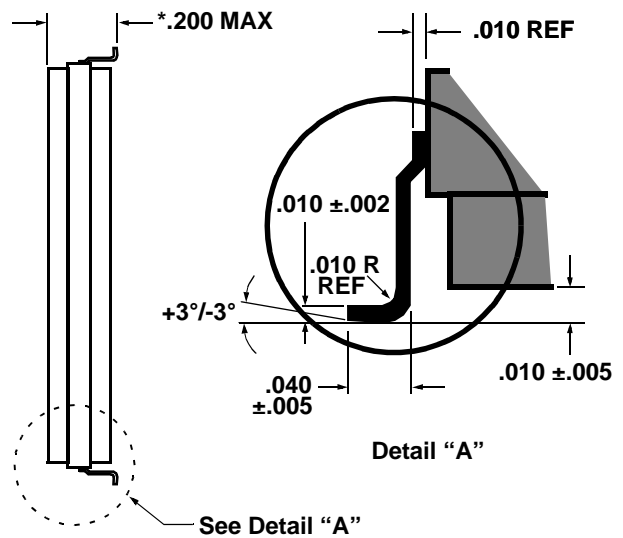
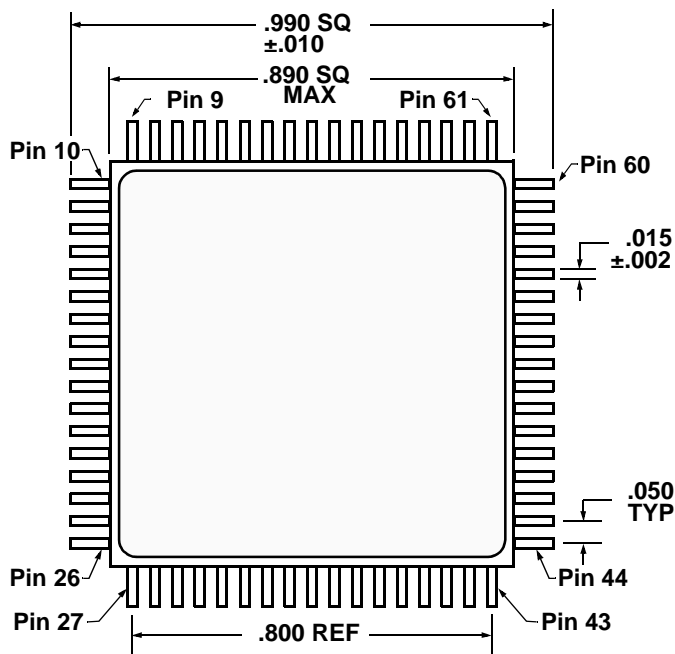

*.180 MAX available, call factory for details

All dimensions in inches



Ordering Information

Model Number	DESC Part Number	Speed	Package
ACT-SF512K32N-26P1X	TBD	25(S) / 60(F) ns	1.385"sq PGA-Type
ACT-SF512K32N-37P1X	TBD	35(S) / 70(F) ns	1.385"sq PGA-Type
ACT-SF512K32N-39P1X	TBD	35(S) / 90(F) ns	1.385"sq PGA-Type
ACT-SF512K32N-26F2X	TBD	25(S) / 60(F) ns	.88"sq CQFP
ACT-SF512K32N-37F2X	TBD	35(S) / 70(F) ns	.88"sq CQFP
ACT-SF512K32N-39F2X	TBD	35(S) / 90(F) ns	.88"sq CQFP

Note: (S) = Speed for SRAM, (F) = Speed for FLASH

Part Number Breakdown

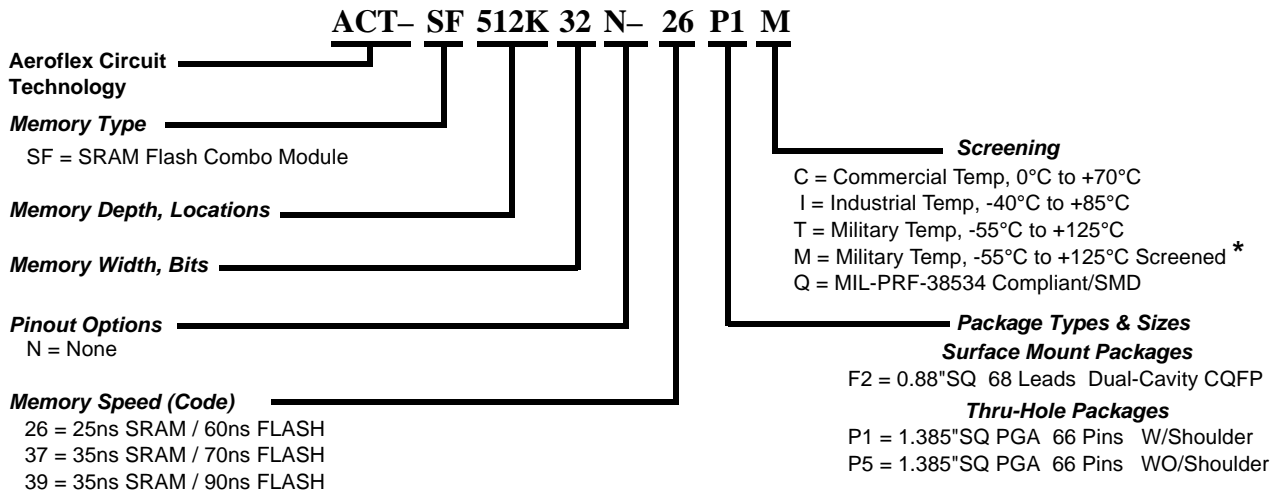

* Screened to the individual test methods of MIL-STD-883

Aeroflex Circuit Technology 35 South Service Road Plainview New York 11830	Telephone: (516) 694-6700 FAX: (516) 694-6715 Toll Free Inquiries: 1-(800) 843-1553
---	--