

# ACT4423 DUAL TRANSCEIVER FOR MIL-STD-1553/1760



## Features

- +5 / +12 Volt Power Supply Operation
- Eliminates Negative Power Supply
- Low Power Dissipation
- Small Size & Light Weight
- Dual Transceivers Saves Space & Cost
- Outstanding MIL-STD-1553 performance
- Radiation Hard Dielectric Isolation Monolithic Construction for Severe Environments
- Superior High Frequency Line Transient and Input Ripple Rejection
- Input and Output TTL Compatible Design
- Processed and Screened to MIL-STD-883 Specs
- MIL-PRF-38534 Compliant Devices Available
- DESC SMD (Standard Military Drawing) Pending

## General Description

The Aeroflex Circuit Technology ACT4423 is a next generation monolithic transceiver design which provides full compliance to MIL-STD-1553A/B and 1760 requirements in a small package with low power consumption.

The ACT4423 series performs the front-end analog function of inputting and outputting data through a transformer to the MIL-STD-1553 data bus.

Design of this transceiver reflects particular attention to active filter performance. This results in low bit and word error rate with superior waveform purity and minimal zero crossover distortion. Efficient transmitter electrical and thermal design provides low internal power dissipation and heat rise at high as well as low duty cycles.

Each channel of the dual transceiver is completely separate from the other and fully independent. This includes power leads as well as signal lines. Hence, each channel may be connected to a different data bus with no interaction.

### Transmitter:

The Transmitter section accepts bi-phase TTL data at the input and when coupled to the data bus with a 1:1 ratio transformer, isolated on the data bus side with two 52.5 Ohm fault isolation resistors, and loaded by two 70 Ohm terminations, the data bus signal is

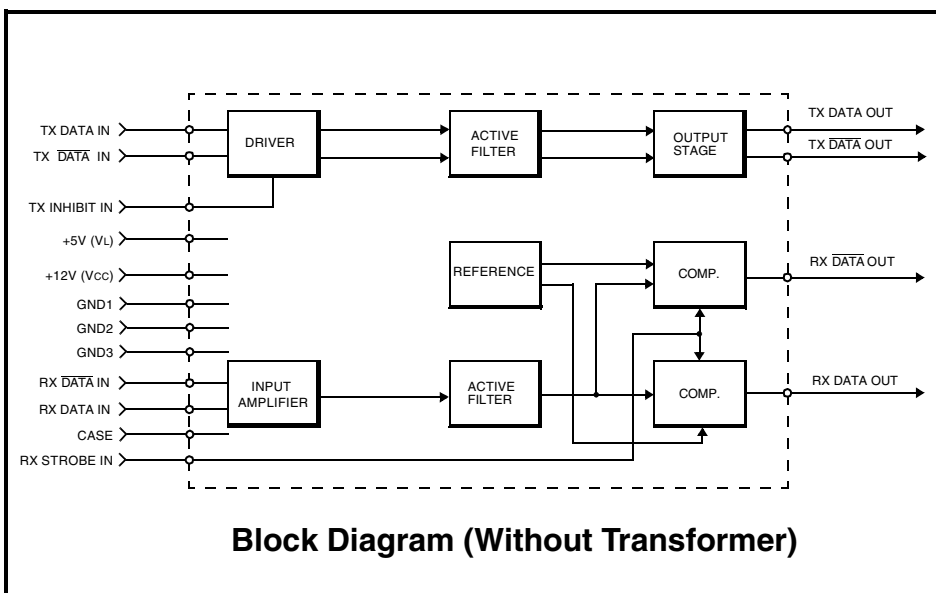

typically 7.5 Volts P-P at point A (See Figure 5). When both DATA and  $\overline{\text{DATA}}$  inputs are held low or high, the transmitter output becomes a high impedance and is "removed" from the line. In addition, an overriding "INHIBIT" input provides for the removal of the transmitter output from the line. A logic "1" signal applied to the "INHIBIT" takes priority over the condition of the data inputs and disables the transmitter (See Transmitter Logic Waveform, Figure 1).

The Transmitter may be safely operated for an indefinite period with the bus (point A) short circuited at 100% duty cycle.

**Receiver:**

The Receiver section accepts bi-phase differential data at the input and produces two TTL signals at the output. The outputs are DATA and  $\overline{\text{DATA}}$ , and represent positive and negative excursions of the input beyond a pre-determined threshold (See Receiver Logic Waveform, Figure 2).

The pre-set internal thresholds will detect data bus signals, point A Figure 5, exceeding 1.20 Volts P-P and reject signals less than 0.6 Volts P-P when used with a transformer (See Figure 5 for transformer data and typical connection).

A low level at the RX Strobe input inhibits the DATA and  $\overline{\text{DATA}}$  outputs. If unused, a 2K pull-up to +5 Volts is recommended.

**Figure 1 — Transmitter Logic Waveforms Idealized**

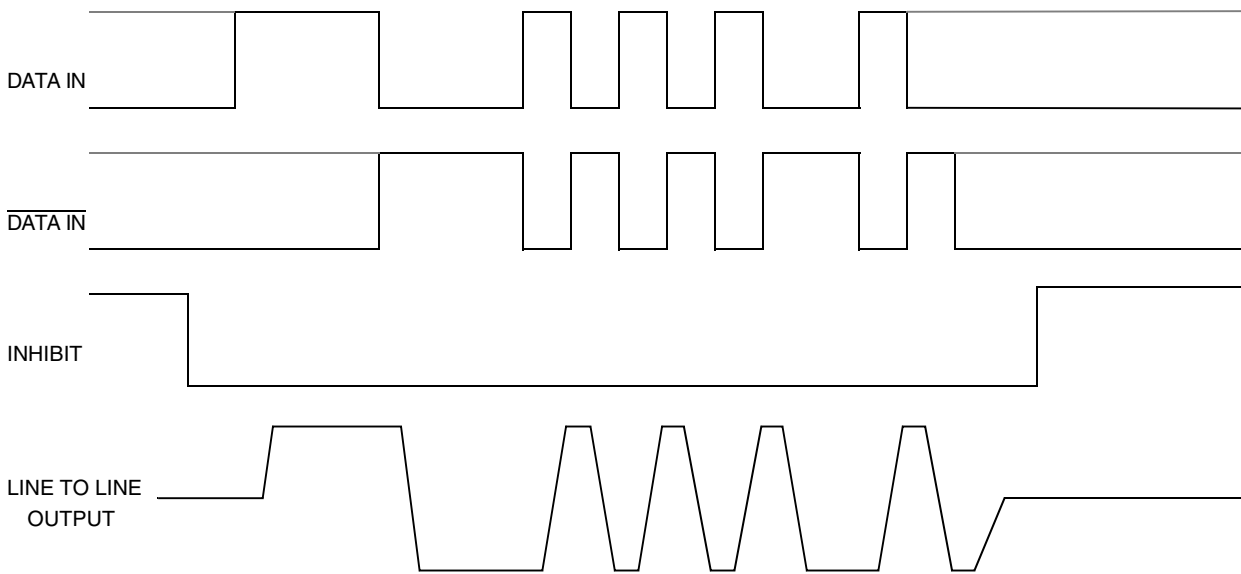

**Note:** DATA and  $\overline{\text{DATA}}$  inputs must be complementary waveforms or 50% duty cycle average, with no delays between them, and must be in the same state during off times (both high or low).

**Figure 2 — Receiver Logic Waveforms Idealized (ACT4423)**

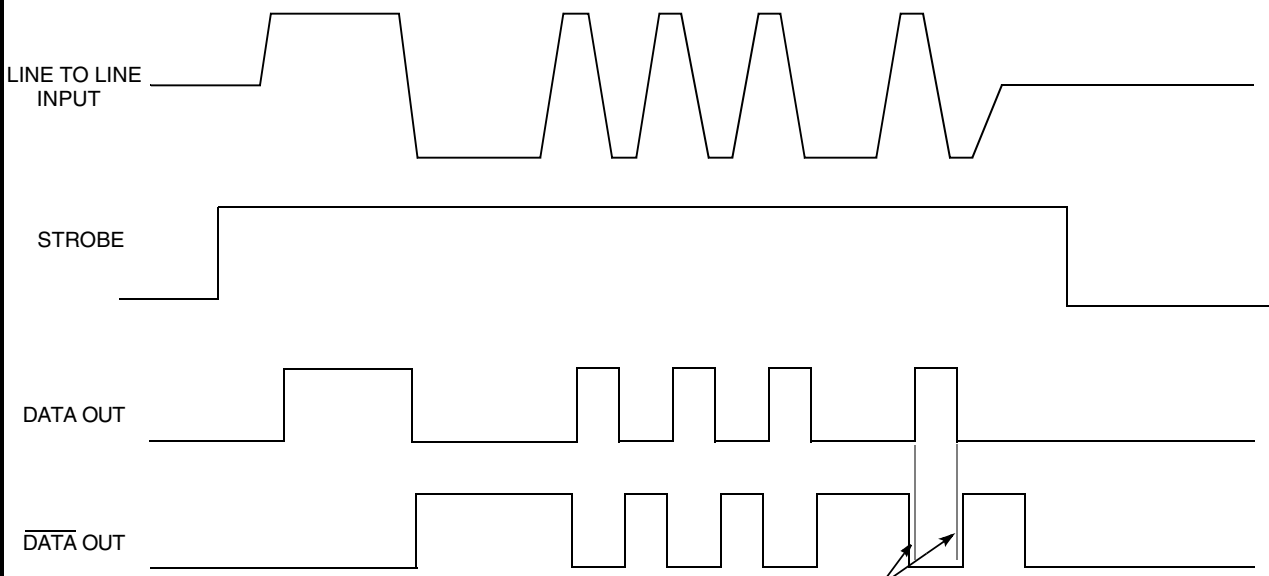

Note overlap

## Absolute Maximum Ratings

Operating case temperature	-55°C to +125°C
Storage case temperature	-65°C to +150°C
Power supply voltage V <sub>CC</sub> V <sub>L</sub>	-0.3 V to +18 V -0.3 V to +7.0 V
Logic input voltage	-0.3 V to +5.5 V
Receiver differential input	±40 VP-P
Receiver input voltage (common mode)	±10 V
Driver peak output current	300 mA
Total package power dissipation over the full operating case temperature rise	2.5 Watts (Note: Normal operation conditions require one transceiver on and the other off)
Maximum junction to case temperature	10°C
Thermal resistance – junction to case	4°C/W

## Electrical Characteristics — Driver Section

### Input Characteristics, TX DATA IN or TX DATA IN (Notes 2 & 3 apply)

Parameter	Condition	Symbol	Min	Typ	Max	Unit
"0" Input Current	V <sub>IN</sub> = 0.4 V	I <sub>ILD</sub>		-0.1	-0.2	mA
"1" Input Current	V <sub>IN</sub> = 2.7 V	I <sub>IHD</sub>		1	40	μA
"0" Input Voltage		V <sub>IHD</sub>			0.7	V
"1" Input Voltage		V <sub>IHD</sub>	2.0			V

### Inhibit Characteristics

"0" Input Current	V <sub>IN</sub> = 0.4 V	I <sub>ILI</sub>		-0.1	-0.2	mA
"1" Input Current	V <sub>IN</sub> =2.7V	I <sub>IHI</sub>		1.0	40	μA
"0" Input Voltage		V <sub>ILI</sub>			0.7	V
"1" Input Voltage		V <sub>IHI</sub>	2.0			V
Delay from TX inhibit, (0→1) to inhibited output	From mid pt inhibit to ±1.2V pt B, See Figure 5	t <sub>DXOFF</sub>		175	225	nS
Delay from TX inhibit, (1→0) to active output		t <sub>DXON</sub>		90	150	nS
Differential output noise, inhibit mode		V <sub>NOI</sub>		2	10	mV <sub>P-P</sub>
Differential output impedance (inhibited) Note 1 See Figure 5	Point B	Z <sub>OI</sub>	2K			Ω
	Point C	Z <sub>OI</sub>	1K			Ω

### Output Characteristics

Differential output level, See Figure 5 See Figure 5	Point A	V <sub>O</sub>	6	7.5	9	V <sub>P-P</sub>
Rise and fall times(10% to 90% at pt A output) See Figure 5	Point A	t <sub>r</sub>	100	160	300	nS
Output offset, Figure 3, 2.5μS after midpoint crossing of the parity bit of the last word of a 660μS message See Figure 5	Point A	V <sub>OS</sub>			± 90	mV peak
Delay from 50% point of TX DATA or TX DATA input to zero crossing of differential signal. See Fig 5	Point A	t <sub>DXT</sub>		100	200	nS

## Electrical Characteristics — Receiver Section

Parameter	Condition	Symbol	Min	Typ	Max	Unit
Differential Receiver Input Voltage Range (See Figure 5, Point B)	TXFMR 1:1	$V_{IDR}$			40	$V_{P-P}$
Common Mode Rejection Ratio (Note 3)		CMRR	45			dB
"1" State – Rx Data or Rx $\overline{\text{Data}}$ Output	$I_{OH} = -0.4 \text{ mA}$	$V_{OH}$	2.5	3.7		V
"0" State – Rx Data or Rx $\overline{\text{Data}}$ Output	$I_{OI} = 4 \text{ mA}$	$V_{OL}$		0.35	0.5	V
Delay (average) from Differential Input Zero Crossings to RX DATA and RX $\overline{\text{DATA}}$ Output 50% points		$t_{DXT}$		270	400	nS
Input Threshold Voltage (referred to the bus)	100KHz–1MHz	$V_{TH}$	0.60	0.75	1.20	$V_{P-P}$

### Strobe Characteristics (Logic "0" Inhibits Output)

"0" Input Current	$V_S=0.4V$	$I_{IL}$		-0.1	-0.2	mA
"1" Input Current	$V_S=2.7V$	$I_{IH}$		1	+40	$\mu A$
"0" Input Voltage		$V_{IL}$			0.7	V
"1" Input Voltage		$V_{IH}$	2.0			V
Strobe Delay (Turn-on or Turn-off)		$t_{SD}$		50	100	nS

### Power Data

#### Power Supply Currents – Per Channel – See Figure 4

Transmitter Standby		$I_{CC}$ $I_L$		0 18	30 30	mA
25% duty cycle		$I_{CC}$ $I_L$		75 18	80 30	
50% duty cycle		$I_{CC}$ $I_L$		120 18	130 30	
100% duty cycle		$I_{CC}$ $I_L$		210 18	230 30	

#### Power Supply Voltages

+12V Operating Power Supply Voltage Range		$V_{CC}$	+14.25	+15.00	+15.75	V
+5V Operating Power Supply Voltage Range)		$V_L$	+4.75	+5.00	+5.25	V

Note 1. Power on or off, measured from 75KHz to 1MHz at point A and transformer self impedance of 3K $\Omega$  minimum at 1MHz.

Note 2: Power Supplies: +12 Volts  $\pm 0.75 \text{ V}$  & +5 Volts  $\pm 0.25 \text{ V}$ , bypassed by 10  $\mu\text{F}$  (Tantalum recommended) Capacitor minimum. All measurements & specifications apply over the temperature range of -55°C to +125°C (case temperature) unless otherwise specified.

Note 3: When measured as shown per Figure 5 with  $\pm 10 \text{ Volt peak}$ , line to ground, DC to 2MHz

Note 4: Typical power is measured with  $V_{BUS}$  at point A = 7.5  $V_{P-P}$

**Figure 3 – Transmitter (TX) Output Offset**

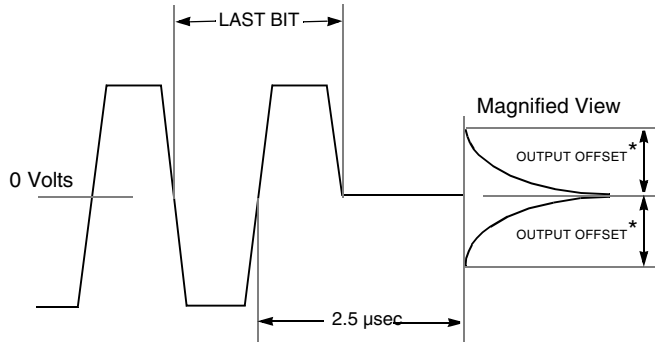

\*Offset measured at point A in Figure 5

**Figure 4 – Hybrid Power Dissipation vs. Duty Cycle  
(Total hybrid with one channel transmitting and the other not powered – 100% Duty Cycle)**

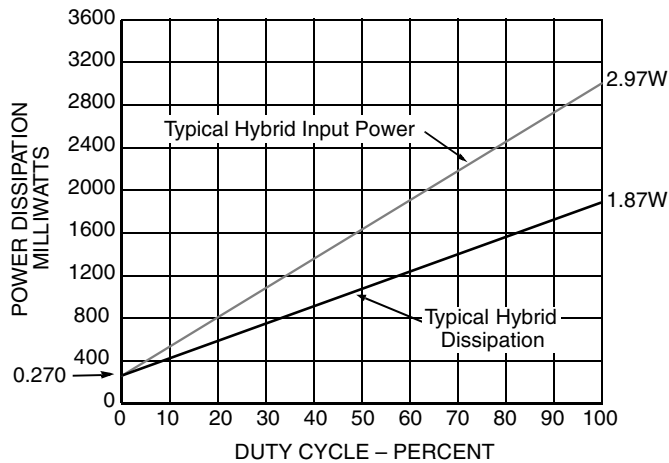

Note:  $V_{CC} = +12V$ ,  $V_L = +5V$ , Transformer ratio 1:1,  $V_{BUS}$  (point A) at 7.5V<sub>P-P</sub>.

**Figure 5 – Typical 1553 Bus Connections**

**Transformer Coupled Stub**

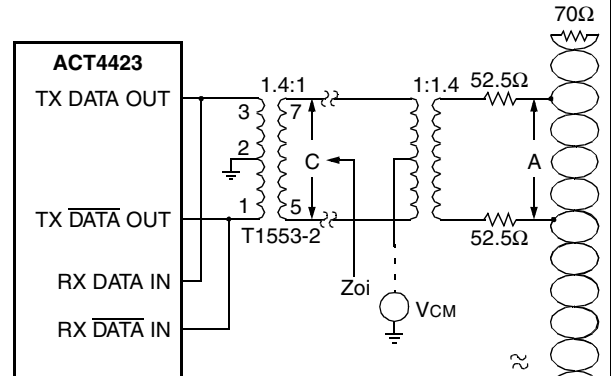

**Direct Coupled Stub**

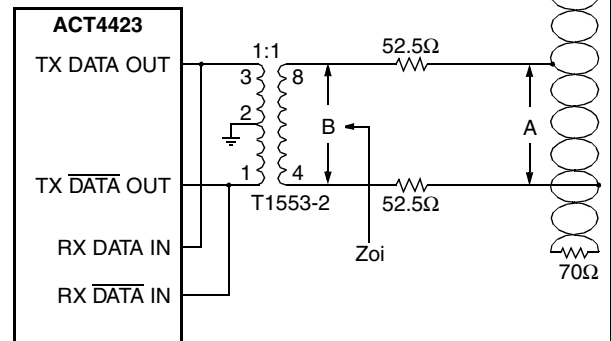

Transformer Model use Technitrol Part# 1553-1 or equivalent

**Configurations and Ordering Information**

ACT Model # / Ordering Part #	Case Style	DESC Number	Rx Standby
ACT4423-D	DIP	Pending	Normally Low
ACT4423-DI	DIP	Pending	Normally High
ACT4423-DF	FP	Pending	Normally Low
ACT4423-DFI	FP	Pending	Normally High

Specifications subject to change without notice.

**Figure 6 – Lead Numbers & Functions**

<b>ACT4423</b>		
<b>Pin #</b>	<b>Function</b>	<b>Channel</b>
1	TX DATA OUT	A
2	TX $\overline{\text{DATA}}$ OUT	A
3	GROUND 1	A
4	NC	
5	RX DATA OUT	A
6	STROBE	A
7	GROUND 2	A
8	RX $\overline{\text{DATA}}$ OUT	A
9	CASE	
10	TX DATA OUT	B
11	TX $\overline{\text{DATA}}$ OUT	B
12	GROUND 1	B
13	NC	
14	RX DATA OUT	B
15	STROBE	B
16	GROUND 2	B
17	RX $\overline{\text{DATA}}$ OUT	B
18	NC	
19	Vcc	B
20	RX DATA IN	B
21	RX $\overline{\text{DATA}}$ IN	B
22	GROUND 3	B
23	NC	
24	+5 V (VL)	B
25	INHIBIT	B
26	TX DATA IN	B
27	TX $\overline{\text{DATA}}$ IN	B
28	Vcc	A
29	RX DATA IN	A
30	RX $\overline{\text{DATA}}$ IN	A
31	GROUND 3	A
32	NC	A
33	+5 V (VL)	A
34	INHIBIT	A
35	TX DATA IN	A
36	TX $\overline{\text{DATA}}$ IN	A

### Model ACT4423 Dual In Line

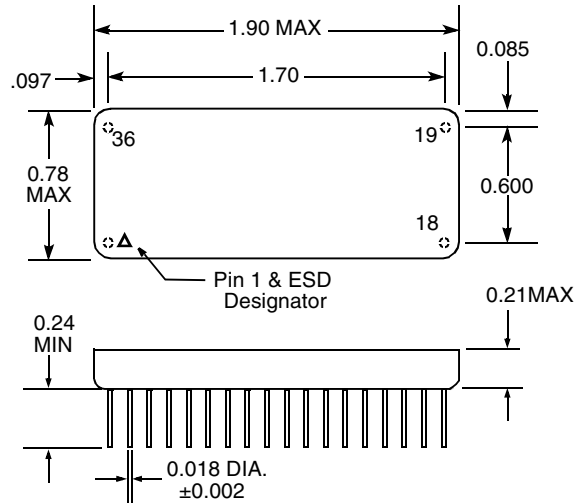

### Model ACT4423 Flat Package

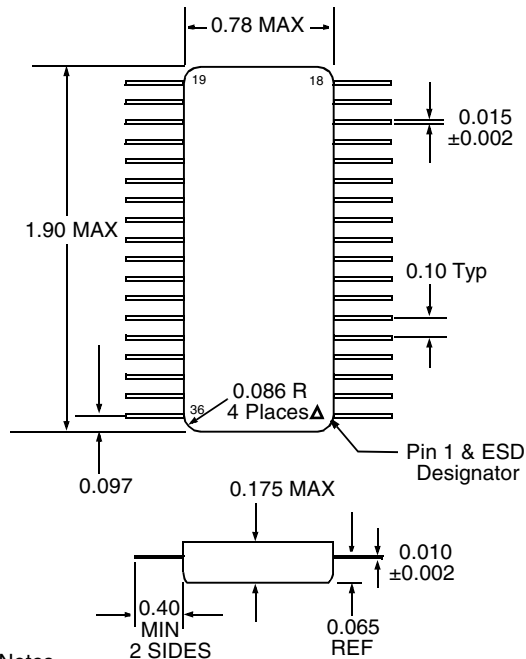

#### Notes

1. Dimensions shown are in inches
2. Pins are equally spaced at 0.100±0.002 tolerance, non-cumulative, each row

**Aeroflex Circuit Technology**  
 35 South Service Road  
 Plainview New York 11830  
 www.aeroflex.com

**Telephone: (516) 694-6700**  
**FAX: (516) 694-6715**  
**Toll Free Inquiries: (800) THE-1553**  
**E-Mail: sales-act@aeroflex.com**