



General Purpose Temperature Probe

AC2626

FEATURES

Linear Current Output: $1\mu\text{A}/\text{K}$
Wide Range: -55°C to $+150^{\circ}\text{C}$
Laser Trimmed Sensor (AD590) to $\pm 1.0^{\circ}\text{C}$ Calibration Accuracy (AC2626L)
Excellent Linearity: $\pm 0.4^{\circ}\text{C}$ Over Full Range (AC2626L)
6 Inch or 4 Inch Standard, Stainless Steel Sheath
3/16 Inch in Outside Diameter
3 Feet Teflon Coated Lead Wire
Wide Power Supply Range $+4\text{V}$ to $+30\text{V}$
Low Cost
Fast Response: 2 Seconds (In Stirred Water)
Sensor Isolated From Sheath



PRODUCT DESCRIPTION

The AC2626 is a stainless steel tubular probe measuring 3/16 inch (4.76mm) in outside diameter and is available in 6 inch (152.4mm) or 4-inch (101.6mm) lengths. The probe is available in linearity grades of 0.3°C , 0.4°C , 0.8°C or 1.5°C .

The probe is designed for both liquid and gaseous immersion applications as well as temperature measurements in refrigeration or any general temperature monitoring application.

For taking measurements in pipes or other closed vessels, the AC2629 compression fitting is available. The AC2629 may be applied anywhere along the probe and is supplied in two materials. The low cost AC2629B is constructed of brass and the higher priced AC2629SS is made of stainless steel.

PRODUCT HIGHLIGHTS

The AC2626 is based on the AD590 temperature transducer, a two terminal integrated circuit which produces an output current linearly proportional to absolute temperature.

Costly linearization circuitry, precision voltage amplifiers, resistance measuring circuitry and cold junction compensation are not needed in applying the AC2626.

Due to the high impedance current output of the AD590, the AC2626 is particularly useful in remote sensing applications, because of its insensitivity to voltage drops over lines. The output characteristics also make the AC2626 easy to multiplex.

In addition to temperature measurement, applications include temperature compensation, biasing proportional to absolute temperature, flow rate measurement, level detection of fluids and anemometry.

DIRECT INTERFACE PRODUCTS

For display and/or control applications, two companion products are available. The AD2038, 6 channel digital thermometer,

and the AD2040, low cost temperature indicator, were designed to be used in conjunction with the AC2626.

1. The AD2038 is a low cost, ac line powered 6 channel digital scanning thermometer designed to interface to printers, computers, serial data transmitters, etc., for display, control, logging or transmission of multi-point temperature data. Channel selection is made via three methods: manual, using the switch provided on the front; auto/scan, where the AD2038 cycling on an internal clock can continually scan the six input channels or external selection, where control inputs provided on the rear connector enable channel selection via external BCD coding.
2. The AD2040 is a low cost, 3 digit temperature indicator. An internal precision voltage reference, resistor network and span and zero adjusts allow the AD2040 to read out directly in $^{\circ}\text{C}$, $^{\circ}\text{F}$, K or R. User selectable readout as well as all other connections, i.e., $+5\text{V}$ dc power and AC2626 interface are all made via the terminal block on the rear.

APPLICATION HINTS

1. Under all operating conditions, a minimum 4V dc must be present across the AC2626.
2. Use of twisted pair wiring is recommended, particularly for remote applications or in high noise environments. Shielded wire is desirable in severe noise environments.
3. For the lowest cost, the J and K grades are recommended. Where probe interchangeability is desired, grade L is recommended.

AC2626 — SPECIFICATIONS (typical @ +25°C and +5V unless otherwise specified)

MODEL	AC2626J	AC2626K	AC2626L	AC2626M
ABSOLUTE MAXIMUM RATINGS¹				
Forward Voltage (V _F)	+44V	•	•	•
Reverse Voltage (V _R)	-20V	•	•	•
Breakdown Voltage (Case to Leads)	±200V	•	•	•
Rated Performance Temp. Range	-55°C to +150°C	•	•	•
Storage Temperature Range	-60°C to +160°C	•	•	•
POWER SUPPLY				
Operating Voltage Range	+4V to +30V	•	•	•
OUTPUT				
Nominal Current Output @ +25°C (298.2°K)	298.2μA	•	•	•
Nominal Temperature Coefficient	1μA/°C	•	•	•
Calibration Error @ +25°C	±5.0°C max	±2.5°C max	±1.0°C max	±0.5°C max
Absolute Error (over rated performance temperature range)				
Without External Calibration Adjustment	±10.0°C max	+5.5°C max	+3.0°C max	±1.7°C max
With +25°C Calibration Error Set to Zero	±3.0°C max	±2.0°C max	±1.6°C max	±1.0°C max
Nonlinearity	±1.5°C max	±0.8°C max	±0.4°C max	±0.3°C max
Repeatability ²	0.1°C	•	•	•
Long Term Drift ³	0.1°C max/month	•	•	•
Time Constant ⁴ (in stirred water)	2 sec.	•	•	•
Current Noise	40pA/√Hz	•	•	•
Power Supply Rejection				
+4V ≤ V _S ≤ +5V	0.5μA/V	•	•	•
+5V ≤ V _S ≤ +15V	0.2μA/V	•	•	•
+15V ≤ V _S ≤ +30V	0.1μA/V	•	•	•
Electrical Turn-On Time	20μs	•	•	•
+ Lead Color	yellow	orange	blue	green

MECHANICAL OUTLINE

Dimensions shown in inches and (mm).

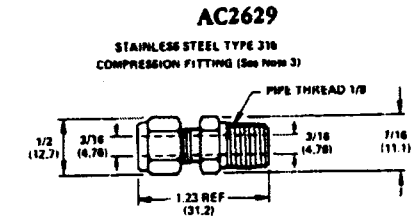
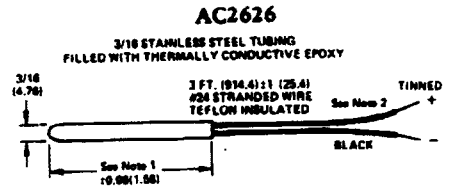

NOTE 1 Probes are available in 4-inch or 6-inch lengths.
 NOTE 2 + lead wire in color coded: J, yellow; K, orange; L, blue.
 NOTE 3 When assembling compression fitting (AC2629) to probe, tighten the 1/2" nut 3/4" of a turn from finger tight.

ORDERING GUIDE

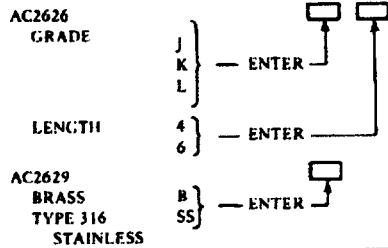

NOTES

- ¹ Maximum safe recommended pressure: 7500psi (5.17 X 10⁸ Kpa).
- ² Maximum deviation between +25°C readings after temperature cycling between -55°C and +150°C; guaranteed, not tested.
- ³ Conditions: constant +5V, constant +125°C; guaranteed, not tested.
- ⁴ The time constant is defined as the time required to reach 63.2% of an instantaneous temperature change.
- *Specifications same as AC2626J.
- *Specifications subject to change without notice.

CALIBRATION

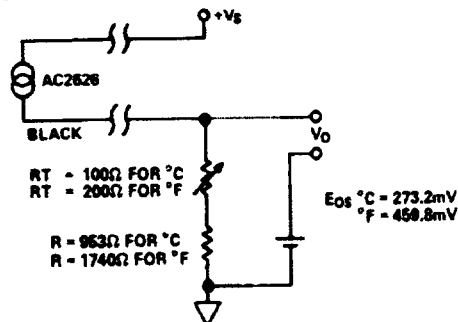

For most applications, a single point calibration is sufficient. With the probe at a known temperature, adjust R_T so that V_O corresponds to the known temperature.

If more detailed information is desired, see the AD580 data sheet and application note.