

FEATURES

- Laser Trimmed to High Accuracy:**
10.000 Volts ± 5 mV (L and U)
- Trimmed Temperature Coefficient:**
5 ppm/ $^{\circ}$ C max, 0° C to $+70^{\circ}$ C (L)
10 ppm/ $^{\circ}$ C max, -55° C to $+125^{\circ}$ C (U)
- Excellent Long-Term Stability:**
25 ppm/1000 hrs. (Noncumulative)
- Negative 10 Volt Reference Capability**
- Low Quiescent Current: 1.0 mA max**
- 10 mA Current Output Capability**
- 3-Terminal TO-5 Package**
- MIL-STD-883 Compliant Versions Available**

FUNCTIONAL BLOCK DIAGRAM

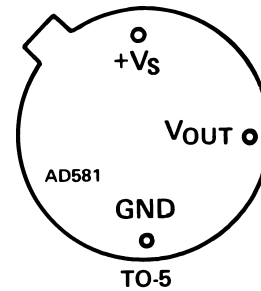

BOTTOM VIEW

PRODUCT DESCRIPTION

The AD581 is a three-terminal, temperature compensated, monolithic bandgap voltage reference which provides a precise 10.00 volt output from an unregulated input level from 12 to 30 volts. Laser Wafer Trimming (LWT) is used to trim both the initial error at $+25^{\circ}$ C as well as the temperature coefficient, which results in high precision performance previously available only in expensive hybrids or oven-regulated modules. The 5 mV initial error tolerance and 5 ppm/ $^{\circ}$ C guaranteed temperature coefficient of the AD581L represent the best performance combination available in a monolithic voltage reference.

The bandgap circuit design used in the AD581 offers several advantages over classical Zener breakdown diode techniques. Most important, no external components are required to achieve full accuracy and stability of significance to low power systems. In addition, total supply current to the device, including the output buffer amplifier (which can supply up to 10 mA) is typically 750 μ A. The long-term stability of the bandgap design is equivalent or superior to selected Zener reference diodes.

The AD581 is recommended for use as a reference for 8-, 10- or 12-bit D/A converters which require an external precision reference. The device is also ideal for all types of A/D converters up to 14-bit accuracy, either successive approximation or integrating designs, and in general can offer better performance than that provided by standard self-contained references.

The AD581J, K, and L are specified for operation from 0° C to $+70^{\circ}$ C; the AD581S, T, and U are specified for the -55° C to $+125^{\circ}$ C range. All grades are packaged in a hermetically sealed three-terminal TO-5 metal can.

*Covered by Patent Nos. 3,887,863; RE 30,586.

PRODUCT HIGHLIGHTS

1. Laser trimming of both initial accuracy and temperature coefficient results in very low errors over temperature without the use of external components. The AD581L has a maximum deviation from 10.000 volts of ± 7.25 mV from 0° C to $+70^{\circ}$ C, while the AD581U guarantees ± 15 mV maximum total error without external trims from -55° C to $+125^{\circ}$ C.
2. Since the laser trimming is done on the wafer prior to separation into individual chips, the AD581 will be extremely valuable to hybrid designers for its ease of use, lack of required external trims, and inherent high performance.
3. The AD581 can also be operated in a two-terminal "Zener" mode to provide a precision negative 10 volt reference with just one external resistor to the unregulated supply. The performance in this mode is nearly equal to that of the standard three-terminal configuration.
4. Advanced circuit design using the bandgap concept allows the AD581 to give full performance with an unregulated input voltage down to 13 volts. With an external resistor, the device will operate with a supply as low as 11.4 volts.
5. The AD581 is available in versions compliant with MIL-STD-883. Refer to the Analog Devices Military Products Databook or current AD581/883B data sheet for detailed specifications.

REV. B

Information furnished by Analog Devices is believed to be accurate and reliable. However, no responsibility is assumed by Analog Devices for its use, nor for any infringements of patents or other rights of third parties which may result from its use. No license is granted by implication or otherwise under any patent or patent rights of Analog Devices.

AD581—SPECIFICATIONS (@ $V_{IN} = +15\text{ V}$ and $+25^\circ\text{C}$)

| Model | AD581J | | | AD581K | | | AD581L | | | Units | |
|---|-------------------|-----|-----------------------|-------------------|-----|-----------------------|-------------------|-----|-----------------------|-----------------------------|--------------------------------------|
| | Min | Typ | Max | Min | Typ | Max | Min | Typ | Max | | |
| OUTPUT VOLTAGE TOLERANCE (Error from Nominal 10,000 V Output) | | | ±30 | | | ±10 | | | ±5 | mV | |
| OUTPUT VOLTAGE CHANGE Maximum Deviation from $+25^\circ\text{C}$ Value, T_{MIN} to T_{MAX} (Temperature Coefficient) | | | ±13.5 30 | | | ±6.75 15 | | | ±2.25 5 | mV ppm/ $^\circ\text{C}$ | |
| LINE REGULATION $15\text{ V} \leq V_{IN} \leq 30\text{ V}$ | | | 3.0 (0.002) | | | 3.0 (0.002) | | | 3.0 (0.002) | mV %/V | |
| $13\text{ V} \leq V_{IN} \leq 15\text{ V}$ | | | 1.0 (0.005) | | | 1.0 (0.005) | | | 1.0 (0.005) | mV %/V | |
| LOAD REGULATION $0 \leq I_{OUT} \leq 5\text{ mA}$ | | | 200 | 500 | | 200 | 500 | | 200 | 500 | $\mu\text{V}/\text{mA}$ |
| QUIESCENT CURRENT | | | 0.75 | 1.0 | | 0.75 | 1.0 | | 0.75 | 1.0 | mA |
| TURN-ON SETTLING TIME TO 0.1% ¹ | | | 200 | | | 200 | | | 200 | | μs |
| NOISE (0.1 Hz to 10 Hz) | | | 40 | | | 40 | | | 40 | | μV (p-p) |
| LONG-TERM STABILITY | | | 25 | | | 25 | | | 25 | | ppm/1000 hrs. |
| SHORT-CIRCUIT CURRENT | | | 30 | | | 30 | | | 30 | | mA |
| OUTPUT CURRENT Source @ $+25^\circ\text{C}$ Source T_{MIN} to T_{MAX} Sink T_{MIN} to T_{MAX} Sink -55°C to $+85^\circ\text{C}$ | 10 5 5 – | | | 10 5 5 – | | | 10 5 5 – | | | | mA mA μA mA |
| TEMPERATURE RANGE Specified Operating | 0 –65 | | +70 +150 | 0 –65 | | +70 +150 | 0 –65 | | +70 +150 | | $^\circ\text{C}$ $^\circ\text{C}$ |
| PACKAGE OPTION ² TO-5 (H-03B) | | | AD581JH | | | AD581KH | | | AD581LH | | |

| Model | AD581S | | | AD581T | | | AD581U | | | Units | |
|---|---------------------|-----|-----------------------|---------------------|-----|-----------------------|---------------------|-----|-----------------------|-----------------------------|--------------------------------------|
| | Min | Typ | Max | Min | Typ | Max | Min | Typ | Max | | |
| OUTPUT VOLTAGE TOLERANCE (Error from Nominal 10,000 V Output) | | | ±30 | | | ±10 | | | ±5 | mV | |
| OUTPUT VOLTAGE CHANGE Maximum Deviation from $+25^\circ\text{C}$ Value, T_{MIN} to T_{MAX} (Temperature Coefficient) | | | ±30 30 | | | ±15 15 | | | ±10 10 | mV ppm/ $^\circ\text{C}$ | |
| LINE REGULATION $15\text{ V} \leq V_{IN} \leq 30\text{ V}$ | | | 3.0 (0.002) | | | 3.0 (0.002) | | | 3.0 (0.002) | mV %/V | |
| $13\text{ V} \leq V_{IN} \leq 15\text{ V}$ | | | 1.0 (0.005) | | | 1.0 (0.005) | | | 1.0 (0.005) | mV %/V | |
| LOAD REGULATION $0 \leq I_{OUT} \leq 5\text{ mA}$ | | | 200 | 500 | | 200 | 500 | | 200 | 500 | $\mu\text{V}/\text{mA}$ |
| QUIESCENT CURRENT | | | 0.75 | 1.0 | | 0.75 | 1.0 | | 0.75 | 1.0 | mA |
| TURN-ON SETTLING TIME TO 0.1% ¹ | | | 200 | | | 200 | | | 200 | | μs |
| NOISE (0.1 Hz to 10 Hz) | | | 40 | | | 40 | | | 40 | | μV (p-p) |
| LONG-TERM STABILITY | | | 25 | | | 25 | | | 25 | | ppm/1000 hrs. |
| SHORT-CIRCUIT CURRENT | | | 30 | | | 30 | | | 30 | | mA |
| OUTPUT CURRENT Source @ $+25^\circ\text{C}$ Source T_{MIN} to T_{MAX} Sink T_{MIN} to T_{MAX} Sink -55°C to $+85^\circ\text{C}$ | 10 5 200 5 | | | 10 5 200 5 | | | 10 5 200 5 | | | | mA mA μA mA |
| TEMPERATURE RANGE Specified Operating | –55 –65 | | +125 +150 | –55 –65 | | +125 +150 | –55 –65 | | +125 +150 | | $^\circ\text{C}$ $^\circ\text{C}$ |
| PACKAGE OPTION ² TO-5 (H-03B) | | | AD581SH | | | AD581TH | | | AD581UH | | |

NOTES

¹See Figure 7.

²H = Hermetic Metal Can.

Specifications subject to change without notice.

Specifications shown in **boldface** are tested on all production units at final electrical test. Results from those tests are used to calculate outgoing quality levels. All min and max specifications are guaranteed, although only those shown in **boldface** are tested on all production units.

ABSOLUTE MAXIMUM RATINGS

| | |
|--------------------------------------|-----------------|
| Input Voltage | 40 V |
| Power Dissipation @ +25°C | 600 mW |
| Operating Junction Temperature Range | -55°C to +150°C |
| Lead Temperature (Soldering 10 sec) | +300°C |
| Thermal Resistance | |
| Junction-to-Ambient | 150°C/W |

APPLYING THE AD581

The AD581 is easy to use in virtually all precision reference applications. The three terminals are simply primary supply, ground, and output, with the case grounded. No external components are required even for high precision applications; the degree of desired absolute accuracy is achieved simply by selecting the required device grade. The AD581 requires less than 1 mA quiescent current from an operating supply range of 12 to 30 volts.

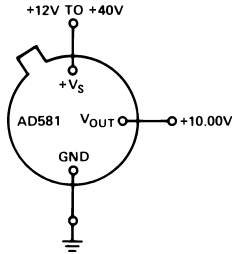

Figure 1. AD581 Pin Configuration (Bottom View)

An external fine trim may be desired to set the output level to exactly 10.000 volts within less than a millivolt (calibrated to a main system reference). System calibration may also require a reference slightly different from 10.00 volts. In either case, the optional trim circuit shown in Figure 2 can offset the output by up to ±30 millivolts (with the 22 Ω resistor), if needed, with minimal effect on other device characteristics.

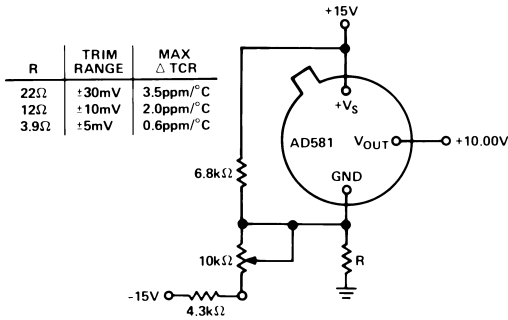

Figure 2. Optional Fine Trim Configuration

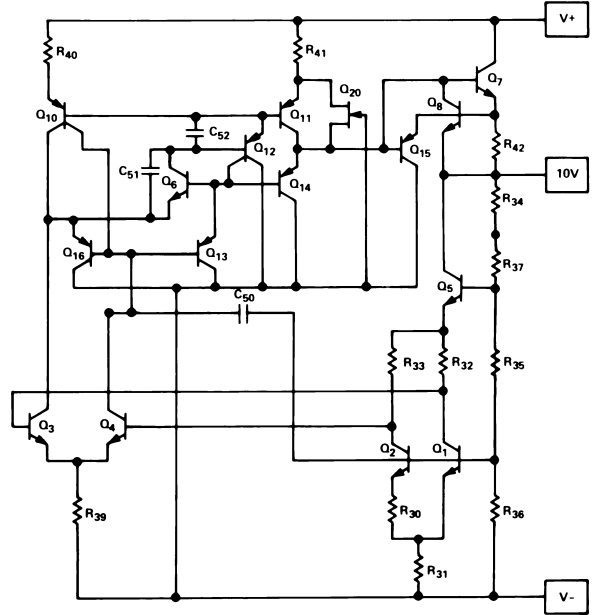

Figure 3. Simplified Schematic

VOLTAGE VARIATION VS. TEMPERATURE

Some confusion exists in the area of defining and specifying reference voltage error over temperature. Historically, references have been characterized using a maximum deviation per degree Centigrade; i.e., 10 ppm/°C. However, because of nonlinearities in temperature characteristics, which originated in standard Zener references (such as “S” type characteristics) most manufacturers have begun to use a maximum limit error band approach to specify devices. This technique involves measurement of the output at 3, 5 or more different temperatures to guarantee that the output voltage will fall within the given error band. The temperature characteristic of the AD581 consistently follows the S-curve shown in Figure 4. Three-point measurement of each device guarantees the error band over the specified temperature range.

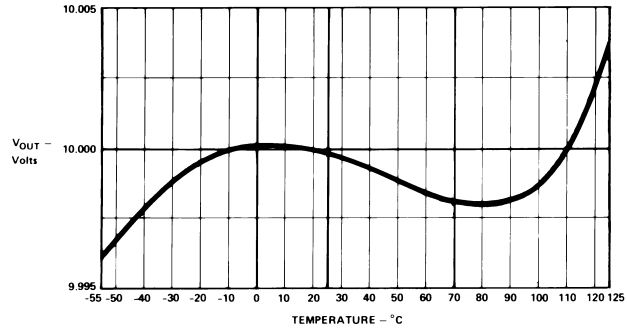

Figure 4. Typical Temperature Characteristic

The error band which is guaranteed with the AD581 is the maximum deviation from the initial value at +25°C; this error band is of more use to a designer than one which simply guarantees the maximum total change over the entire range (i.e., in the latter definition, all of the changes could occur in the positive direction). Thus, with a given grade of the AD581, the designer can easily determine the maximum total error from initial tolerance plus temperature variation (e.g., for the AD581T,

AD581

the initial tolerance is ± 10 mV, the temperature error band is ± 15 mV, thus the unit is guaranteed to be 10.000 volts ± 25 mV from -55°C to $+125^{\circ}\text{C}$).

OUTPUT CURRENT CHARACTERISTICS

The AD581 has the capability to either source or sink current and provide good load regulation in either direction, although it has better characteristics in the source mode (positive current into the load). The circuit is protected for shorts to either positive supply or ground. The output voltage vs. output current characteristics of the device are shown in Figure 5. Source current is displayed as negative current in the figure; sink current is positive. Note that the short circuit current (i.e., zero volts output) is about 28 mA; when shorted to +15 volts, the sink current goes to about 20 mA.

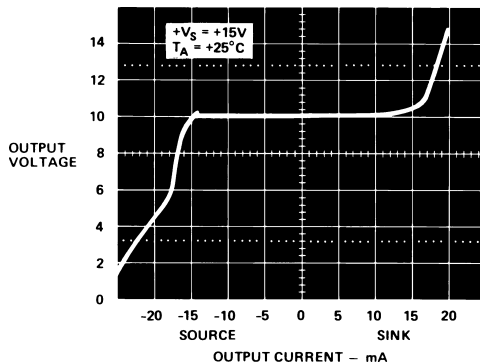

Figure 5. AD581 Output Voltage vs. Sink and Source Current

DYNAMIC PERFORMANCE

Many low power instrument manufacturers are becoming increasingly concerned with the turn-on characteristics of the components being used in their systems. Fast turn-on components often enable the end user to keep power off when not needed, and yet respond quickly when the power is turned on for operation. Figure 6 displays the turn-on characteristic of the AD581. This characteristic is generated from cold-start operation and represents the true turn-on waveform after an extended period with the supplies off. The figure shows both the coarse and fine transient characteristics of the device; the total settling time to within ± 10 millivolt is about 180 μs , and there is no long thermal tail appearing after the point.

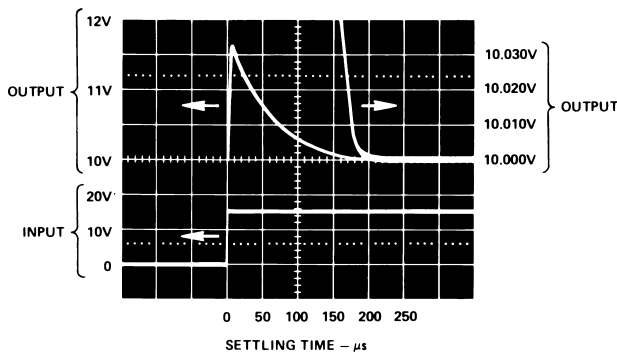

Figure 6. Output Settling Characteristic

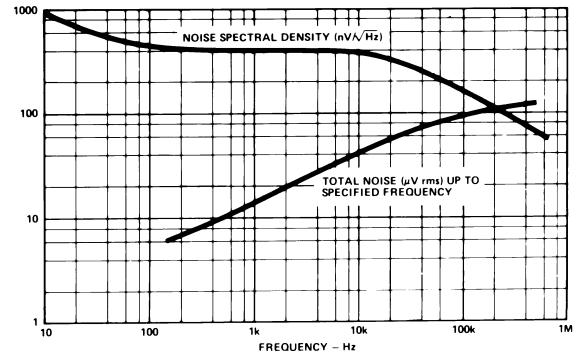

Figure 7. Spectral Noise Density and Total rms Noise vs. Frequency

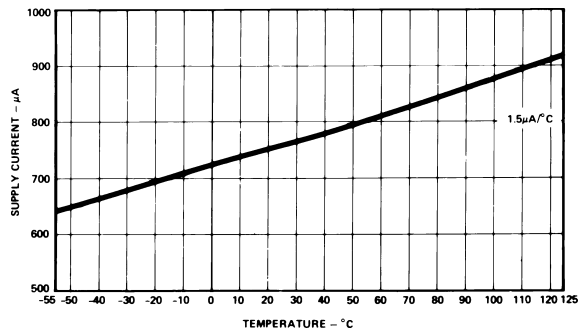

Figure 8. Quiescent Current vs. Temperature

PRECISION HIGH CURRENT SUPPLY

The AD581 can be easily connected with power pnp or power Darlington pnp devices to provide much greater output current capability. The circuit shown in Figure 9 delivers a precision 10 volt output with up to 4 amperes supplied to the load. The 0.1 μF capacitor is required only if the load has a significant capacitive component. If the load is purely resistive, improved high frequency supply rejection results from removing the capacitor.

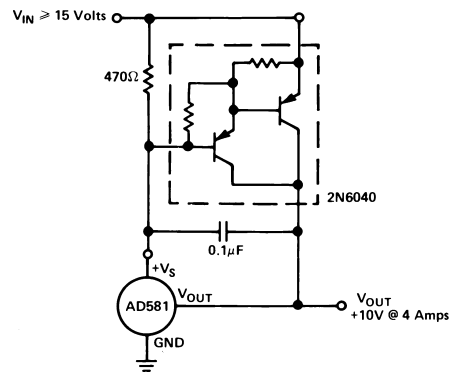

Figure 9. High Current Precision Supply

CONNECTION FOR REDUCED PRIMARY SUPPLY

While line regulation is specified down to 13 volts, the typical AD581 will work as specified down to 12 volts or below. The current sink capability allows even lower supply voltage capability such as operation from $12\text{ V} \pm 5\%$ as shown in Figure 10. The $560\ \Omega$ resistor reduces the current supplied by the AD581 to a manageable level at full 5 mA load. Note that the other bandgap references, without current sink capability, may be damaged by use in this circuit configuration.

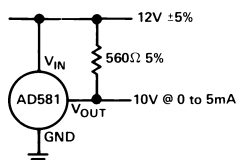

Figure 10. 12-Volt Supply Connection

THE AD581 AS A CURRENT LIMITER

The AD581 represents an alternative to current limiter diodes which require factory selection to achieve a desired current. This approach often results in temperature coefficients of $1\%/^{\circ}\text{C}$. The AD581 approach is not limited to a defined set current limit; it can be programmed from 0.75 mA to 5 mA with the insertion of a single external resistor. Of course, the minimum voltage required to drive the connection is 13 volts. The AD580, which is a 2.5 volt reference, can be used in this type of circuit with compliance voltage down to 4.5 volts.

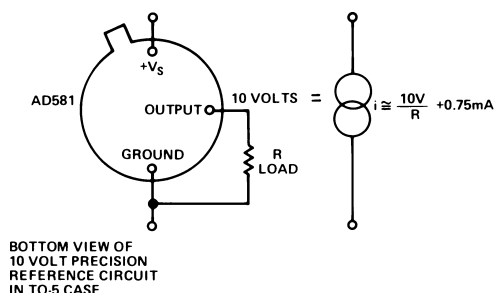

Figure 11. A Two-Component Precision Current Limiter

NEGATIVE 10-VOLT REFERENCE

The AD581 can also be used in a two-terminal “Zener” mode to provide a precision -10.00 volt reference. As shown in Figure 12, the V_{IN} and V_{OUT} terminals are connected together to the high supply (in this case, ground). The ground pin is connected through a resistor to the negative supply. The output is now taken from the ground pin instead of V_{OUT} . With 1 mA flowing through the AD581 in this mode, a typical unit will show a 2 mV increase in output level over that produced in the three-terminal mode. Note also that the effective output impedance in this connection increases from $0.2\ \Omega$ typical to 2 ohms. It is essential to arrange the output load and the supply resistor, R_{S} , so that the net current through the AD581 is always between 1 mA and 5 mA. For operation to $+125^{\circ}\text{C}$, the net current should be between 2 mA and 5 mA. The temperature characteristics and long-term stability of the device will be essentially the same as that of a unit used in the standard three-terminal mode.

The AD581 can also be used in a two-terminal mode to develop a positive reference. V_{IN} and V_{OUT} are tied together and to the positive supply through an appropriate supply resistor. The performance characteristics will be similar to those of the negative two-terminal connection. The only advantage of this connection over the standard three-terminal connection is that a lower primary supply can be used, as low as 10.5 volts. This type of operation will require considerable attention to load and primary supply regulation to be sure the AD581 always remains within its regulating range of 1 mA to 5 mA (2 mA to 5 mA for operation beyond $+85^{\circ}\text{C}$).

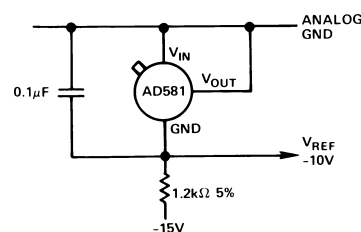

Figure 12. Two Terminal Negative 10-Volt Reference

10 VOLT REFERENCE WITH MULTIPLYING CMOS D/A OR A/D CONVERTERS

The AD581 is ideal for application with the entire AD7533 series of 10- and 12-bit multiplying CMOS D/A converters, especially for low power applications. It is equally suitable for the AD7574 8-bit A/D converter. In the standard hook-up, as shown in Figure 14, the $+10$ volt reference is inverted by the amplifier/DAC configuration to produce a 0 volt to -10 volt range. If an AD308 amplifier is used, total quiescent supply current will typically be 2 mA. If a 0 volt to $+10$ volt full-scale range is desired, the AD581 can be connected to the CMOS DAC in its -10 volt “Zener” mode, as shown in Figure 12 (the -10 V_{REF} output is connected directly to the $V_{\text{REF IN}}$ of the CMOS DAC). The AD581 will normally be used in the -10 volt mode with the AD7574 to give a 0 volt to $+10$ volt ADC range. This is shown in Figure 14. Bipolar output applications and other operating details can be found in the data sheets for the CMOS products.

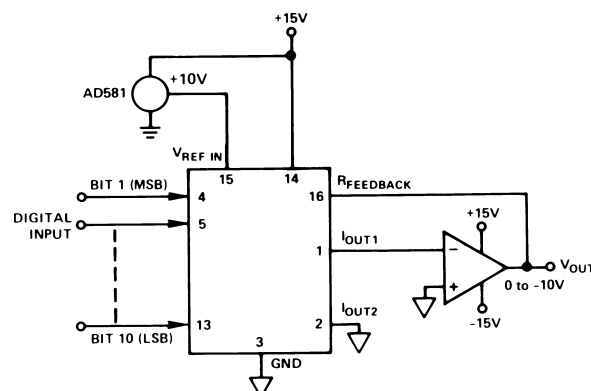
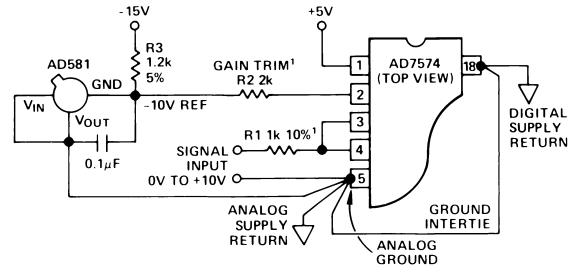

Figure 13. Low Power 10-Bit CMOS DAC Application

AD581

THE PRECISION 12-BIT D/A CONVERTER REFERENCE
 AD562, like most D/A converters, is designed to operate with a +10 volt reference element. In the AD562, this 10 volt reference voltage is converted into a reference current of approximately 0.5 mA via the internal 19.95 kΩ resistor (in series with the external 100 Ω trimmer). The gain temperature coefficient of the AD562 is primarily governed by the temperature tracking of the 19.95 kΩ resistor and the 5k/10k span resistors; gain TC is guaranteed to 3 ppm/°C. Thus, using the AD581L (at 5 ppm/°C) as the 10 volt reference guarantees a maximum full-scale temperature coefficient of 8 ppm/°C over commercial range. The 10 volt reference also supplies the normal 1 mA bipolar offset current through the 9.95k bipolar offset resistor. The bipolar offset TC thus depends only on TC matching of the bipolar offset resistor to the input reference resistor and is guaranteed to 3 ppm/°C.



NOTE 1: R1 AND R2 CAN BE OMITTED IF GAIN TRIM IS NOT REQUIRED

Figure 14. AD581 as Negative 10-Volt Reference for CMOS ADC

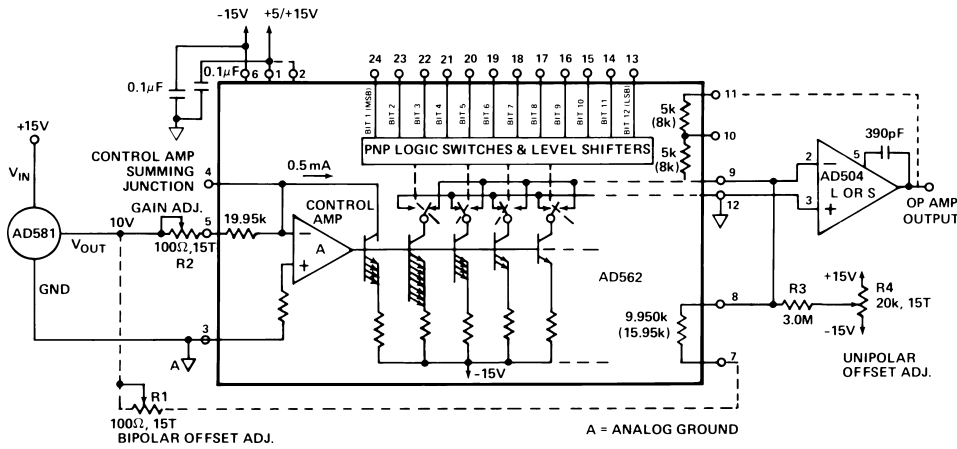

Figure 15. Precision 12-Bit D/A Converter

OUTLINE DIMENSIONS

Dimensions shown in inches and (mm).

