

FEATURES

COMPUTES

- True RMS Value
- Average Rectified Value
- Absolute Value

PROVIDES

- 200 mV Full-Scale Input Range
(Larger Inputs with Input Attenuator)
- High Input Impedance of $10^{12} \Omega$
- Low Input Bias Current: 25 pA max
- High Accuracy: $\pm 0.3 \text{ mV} \pm 0.3\%$ of Reading
- RMS Conversion with Signal Crest Factors Up to 5
- Wide Power Supply Range: +2.8 V, -3.2 V to $\pm 16.5 \text{ V}$
- Low Power: 200 μA max Supply Current
- Buffered Voltage Output
- No External Trims Needed for Specified Accuracy
- AD737—An Unbuffered Voltage Output Version with
Chip Power Down Is Also Available

PRODUCT DESCRIPTION

The AD736 is a low power, precision, monolithic true rms-to-dc converter. It is laser trimmed to provide a maximum error of $\pm 0.3 \text{ mV} \pm 0.3\%$ of reading with sine-wave inputs. Furthermore, it maintains high accuracy while measuring a wide range of input waveforms, including variable duty cycle pulses and triac (phase) controlled sine waves. The low cost and small physical size of this converter make it suitable for upgrading the performance of non-rms "precision rectifiers" in many applications. Compared to these circuits, the AD736 offers higher accuracy at equal or lower cost.

The AD736 can compute the rms value of both ac and dc input voltages. It can also be operated ac coupled by adding one external capacitor. In this mode, the AD736 can resolve input signal levels of 100 μV rms or less, despite variations in temperature or supply voltage. High accuracy is also maintained for input waveforms with crest factors of 1 to 3. In addition, crest factors as high as 5 can be measured (while introducing only 2.5% additional error) at the 200 mV full-scale input level.

The AD736 has its own output buffer amplifier, thereby providing a great deal of design flexibility. Requiring only 200 μA of power supply current, the AD736 is optimized for use in portable multimeters and other battery powered applications.

The AD736 allows the choice of two signal input terminals: a high impedance ($10^{12} \Omega$) FET input which will directly interface with high Z input attenuators and a low impedance (8 k Ω) input

FUNCTIONAL BLOCK DIAGRAM

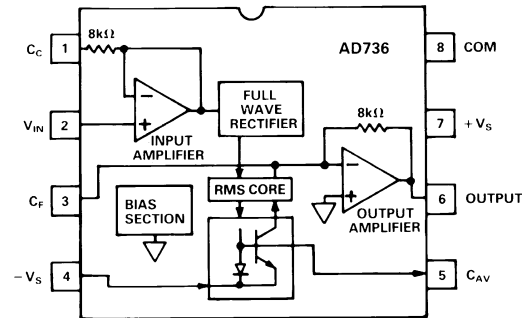

which allows the measurement of 300 mV input levels, while operating from the minimum power supply voltage of +2.8 V, -3.2 V. The two inputs may be used either singly or differentially.

The AD736 achieves a 1% of reading error bandwidth exceeding 10 kHz for input amplitudes from 20 mV rms to 200 mV rms while consuming only 1 mW.

The AD736 is available in four performance grades. The AD736J and AD736K grades are rated over the commercial temperature range of 0°C to +70°C. The AD736A and AD736B grades are rated over the industrial temperature range of -40°C to +85°C.

The AD736 is available in three low-cost, 8-pin packages: plastic mini-DIP, plastic SO and hermetic cerdip.

PRODUCT HIGHLIGHTS

1. The AD736 is capable of computing the average rectified value, absolute value or true rms value of various input signals.
2. Only one external component, an averaging capacitor, is required for the AD736 to perform true rms measurement.
3. The low power consumption of 1 mW makes the AD736 suitable for many battery powered applications.
4. A high input impedance of $10^{12} \Omega$ eliminates the need for an external buffer when interfacing with input attenuators.
5. A low impedance input is available for those applications requiring up to 300 mV rms input signal operating from low power supply voltages.

REV. C

Information furnished by Analog Devices is believed to be accurate and reliable. However, no responsibility is assumed by Analog Devices for its use, nor for any infringements of patents or other rights of third parties which may result from its use. No license is granted by implication or otherwise under any patent or patent rights of Analog Devices.

AD736—SPECIFICATIONS (@ +25°C ±5 V supplies, ac coupled with 1 kHz sine-wave input applied unless otherwise noted.)

Model	Conditions	AD736J/A			AD736K/B			Units
		Min	Typ	Max	Min	Typ	Max	
TRANSFER FUNCTION		$V_{OUT} = \sqrt{Avg.(V_{IN}^2)}$			$V_{OUT} = \sqrt{Avg.(V_{IN}^2)}$			
CONVERSION ACCURACY	1 kHz Sine Wave ac Coupled Using C_C							
Total Error, Internal Trim ¹ All Grades	0–200 mV rms 200 mV–1 V rms		0.3/0.3 –1.2	0.5/0.5 ±2.0		0.2/0.2 –1.2	0.3/0.3 ±2.0	±mV/±% of Reading % of Reading
T_{MIN} – T_{MAX} A&B Grades J&K Grades vs. Supply Voltage	@ 200 mV rms @ 200 mV rms			0.7/0.7		0.007	0.5/0.5	±mV/±% of Reading ±% of Reading/°C
@ 200 mV rms Input	$V_S = \pm 5$ V to ± 16.5 V	0	+0.06	+0.1	0	+0.06	+0.1	%/V
@ 200 mV rms Input	$V_S = \pm 5$ V to ± 3 V	0	–0.18	–0.3	0	–0.18	–0.3	%/V
dc Reversal Error, dc Coupled	@ 600 mV dc		1.3	2.5		1.3	2.5	% of Reading
Nonlinearity ² , 0 mV–200 mV	@ 100 mV rms	0	+0.25	+0.35	0	+0.25	+0.35	% of Reading
Total Error, External Trim	0–200 mV rms		0.1/0.5			0.1/0.3		±mV/±% of Reading
ERROR vs. CREST FACTOR ³								
Crest Factor 1 to 3	$C_{AV}, C_F = 100$ μ F		0.7			0.7		% Additional Error
Crest Factor = 5	$C_{AV}, C_F = 100$ μ F		2.5			2.5		% Additional Error
INPUT CHARACTERISTICS								
High Impedance Input (Pin 2)								
Signal Range								
Continuous rms Level	$V_S = +2.8$ V, -3.2 V			200			200	mV rms
Continuous rms Level	$V_S = \pm 5$ V to ± 16.5 V			1			1	V rms
Peak Transient Input	$V_S = +2.8$ V, -3.2 V	±0.9			±0.9			V
Peak Transient Input	$V_S = \pm 5$ V		±2.7			±2.7		V
Peak Transient Input	$V_S = \pm 16.5$ V	±4.0			±4.0			V
Input Resistance			10^{12}			10^{12}		Ω
Input Bias Current	$V_S = \pm 3$ V to ± 16.5 V		1	25		1	25	pA
Low Impedance Input (Pin 1)								
Signal Range								
Continuous rms Level	$V_S = +2.8$ V, -3.2 V			300			300	mV rms
Continuous rms Level	$V_S = \pm 5$ V to ± 16.5 V			1			1	V rms
Peak Transient Input	$V_S = +2.8$ V, -3.2 V		±1.7			±1.7		V
Peak Transient Input	$V_S = \pm 5$ V		±3.8			±3.8		V
Peak Transient Input	$V_S = \pm 16.5$ V		±11			±11		V
Input Resistance		6.4	8	9.6	6.4	8	9.6	k Ω
Maximum Continuous Nondestructive Input Input Offset Voltage ⁴	All Supply Voltages ac Coupled			±12			±12	V p-p
J&K Grades				±3			±3	mV
A&B Grades				±3			±3	mV
vs. Temperature			8	30		8	30	μ V/°C
vs. Supply	$V_S = \pm 5$ V to ± 16.5 V		50	150		50	150	μ V/V
vs. Supply	$V_S = \pm 5$ V to ± 3 V		80			80		μ V/V
OUTPUT CHARACTERISTICS								
Output Offset Voltage								
J&K Grades			±0.1	±0.5		±0.1	±0.3	mV
A&B Grades				±0.5			±0.3	mV
vs. Temperature			1	20		1	20	μ V/°C
vs. Supply	$V_S = \pm 5$ V to ± 16.5 V		50	130		50	130	μ V/V
	$V_S = \pm 5$ V to ± 3 V		50			50		μ V/V
Output Voltage Swing								
2 k Ω Load	$V_S = +2.8$ V, -3.2 V	0 to +1.6	+1.7		0 to +1.6	+1.7		V
2 k Ω Load	$V_S = \pm 5$ V	0 to +3.6	+3.8		0 to +3.6	+3.8		V
2 k Ω Load	$V_S = \pm 16.5$ V	0 to +4	+5		0 to +4	+5		V
No Load	$V_S = \pm 16.5$ V	0 to +4	+12		0 to +4	+12		V
Output Current		2			2			mA
Short-Circuit Current	@ dc		3			3		mA
Output Resistance	@ dc		0.2			0.2		Ω
FREQUENCY RESPONSE								
High Impedance Input (Pin 2)								
Sine-Wave Input								
For 1% Additional Error								
$V_{IN} = 1$ mV rms			1			1		kHz
$V_{IN} = 10$ mV rms			6			6		kHz
$V_{IN} = 100$ mV rms			37			37		kHz
$V_{IN} = 200$ mV rms			33			33		kHz

AD736

Model	Conditions	AD736J/A			AD736K/B			Units		
		Min	Typ	Max	Min	Typ	Max			
±3 dB Bandwidth V _{IN} = 1 mV rms V _{IN} = 10 mV rms V _{IN} = 100 mV rms V _{IN} = 200 mV rms	Sine-Wave Input		5			5		kHz		
			55			55		kHz		
			170			170		kHz		
			190			190		kHz		
FREQUENCY RESPONSE Low Impedance Input (Pin 1) For 1% Additional Error V _{IN} = 1 mV rms V _{IN} = 10 mV rms V _{IN} = 100 mV rms V _{IN} = 200 mV rms ±3 dB Bandwidth V _{IN} = 1 mV rms V _{IN} = 10 mV rms V _{IN} = 100 mV rms V _{IN} = 200 mV rms	Sine-Wave Input		1			1		kHz		
			6			6		kHz		
			90			90		kHz		
			90			90		kHz		
	Sine-Wave Input		5			5		kHz		
			55			55		kHz		
			350			350		kHz		
			460			460		kHz		
	POWER SUPPLY Operating Voltage Range Quiescent Current 200 mV rms, No Load	Zero Signal Sine-Wave Input		+2.8, -3.2	±5	±16.5	+2.8, -3.2	±5	±16.5	Volts
				160	200		160	200		μA
			230	270		230	270		μA	
TEMPERATURE RANGE Operating, Rated Performance Commercial (0°C to +70°C) Industrial (-40°C to +85°C)			AD736J AD736A			AD736K AD736B				

NOTES

¹Accuracy is specified with the AD736 connected as shown in Figure 16 with capacitor C_C.

²Nonlinearity is defined as the maximum deviation (in percent error) from a straight line connecting the readings at 0 and 200 mV rms. Output offset voltage is adjusted to zero.

³Error vs. Crest Factor is specified as additional error for a 200 mV rms signal. C.F. = V_{PEAK}/V rms.

⁴DC offset does not limit ac resolution.

Specifications are subject to change without notice.

Specifications shown in **boldface** are tested on all production units at final electrical test.

Results from those tests are used to calculate outgoing quality levels.

ABSOLUTE MAXIMUM RATINGS¹

Supply Voltage	±16.5 V
Internal Power Dissipation ²	200 mW
Input Voltage	±V _S
Output Short-Circuit Duration	Indefinite
Differential Input Voltage	+V _S and -V _S
Storage Temperature Range (Q)	-65°C to +150°C
Storage Temperature Range (N, R)	-65°C to +125°C
Operating Temperature Range	
AD736J/K	0°C to +70°C
AD736A/B	-40°C to +85°C

Lead Temperature Range (Soldering 60 sec) +300°C

ESD Rating 500 V

NOTES

¹Stresses above those listed under "Absolute Maximum Ratings" may cause permanent damage to the device. This is a stress rating only and functional operation of the device at these or any other conditions above those indicated in the operational section of this specification is not implied. Exposure to absolute maximum rating conditions for extended periods may affect device reliability.

²8-Pin Plastic Package: θ_{JA} = 165°C/W

8-Pin Cerdip Package: θ_{JA} = 110°C/W

8-Pin Small Outline Package: θ_{JA} = 155°C/W

ORDERING GUIDE

Model	Temperature Range	Package Description	Package Option
AD736JN	0°C to +70°C	Plastic Mini-DIP	N-8
AD736KN	0°C to +70°C	Plastic Mini-DIP	N-8
AD736JR	0°C to +70°C	Plastic SOIC	SO-8
AD736KR	0°C to +70°C	Plastic SOIC	SO-8
AD736AQ	-40°C to +85°C	Cerdip	Q-8
AD736BQ	-40°C to +85°C	Cerdip	Q-8
AD736JR-REEL	0°C to +70°C	Plastic SOIC	SO-8
AD736JR-REEL-7	0°C to +70°C	Plastic SOIC	SO-8
AD736KR-REEL	0°C to +70°C	Plastic SOIC	SO-8
AD736KR-REEL-7	0°C to +70°C	Plastic SOIC	SO-8

PIN CONFIGURATION

8-Pin Mini-DIP (N-8), 8-Pin SOIC (R-8),
8-Pin Cerdip (Q-8)

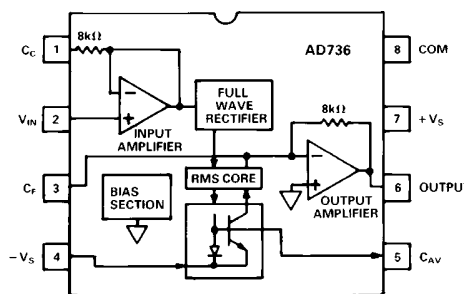

AD736—Typical Characteristics

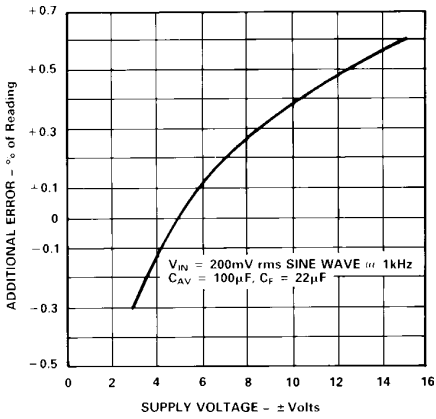

Figure 1. Additional Error vs. Supply Voltage

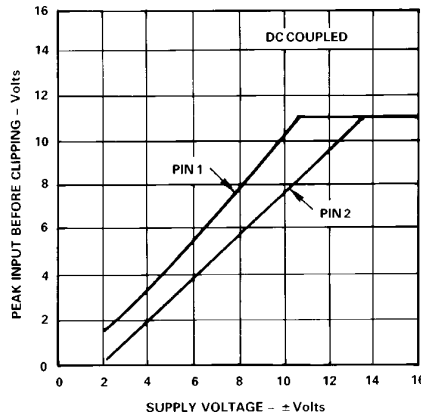

Figure 2. Maximum Input Level vs. Supply Voltage

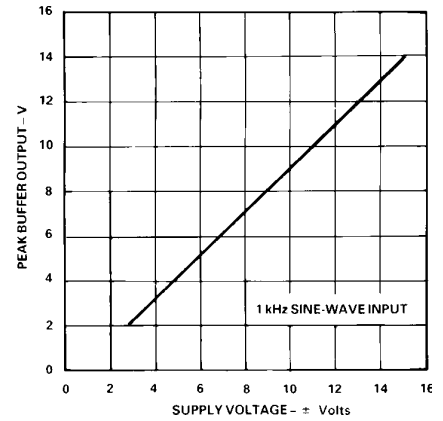

Figure 3. Peak Buffer Output vs. Supply Voltage

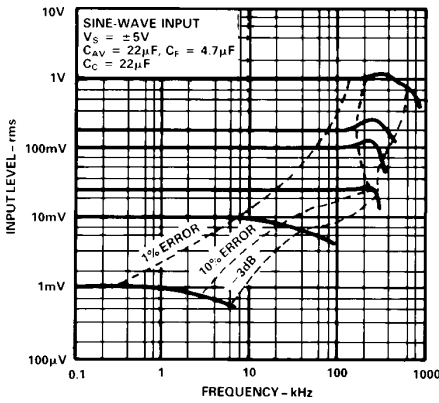

Figure 4. Frequency Response Driving Pin 1

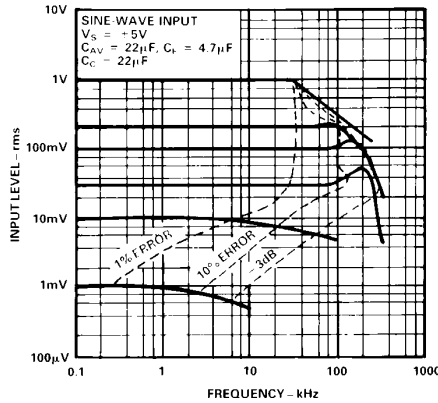

Figure 5. Frequency Response Driving Pin 2

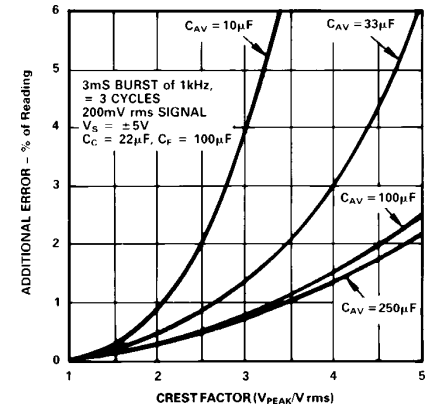

Figure 6. Additional Error vs. Crest Factor vs. C_{AV}

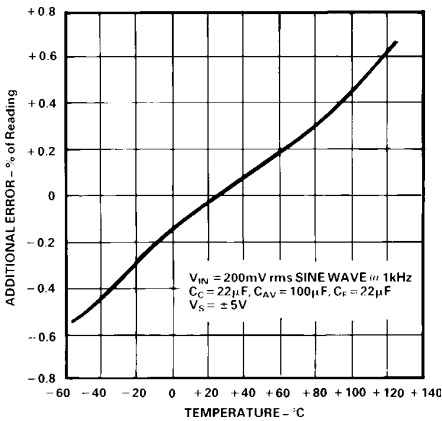

Figure 7. Additional Error vs. Temperature

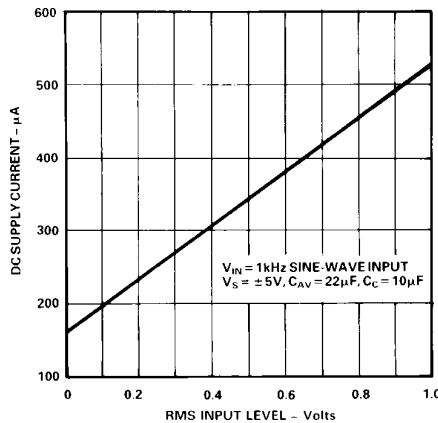

Figure 8. DC Supply Current vs. RMS Input Level

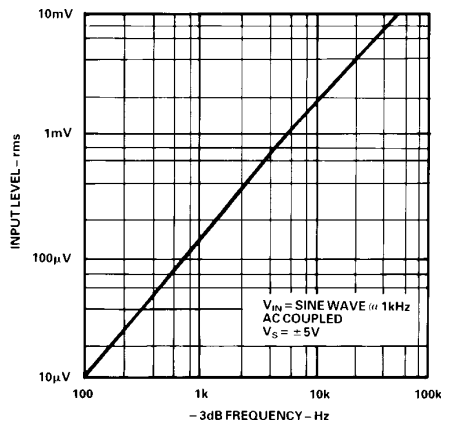

Figure 9. -3 dB Frequency vs. RMS Input Level (Pin 2)

Typical Characteristics—AD736

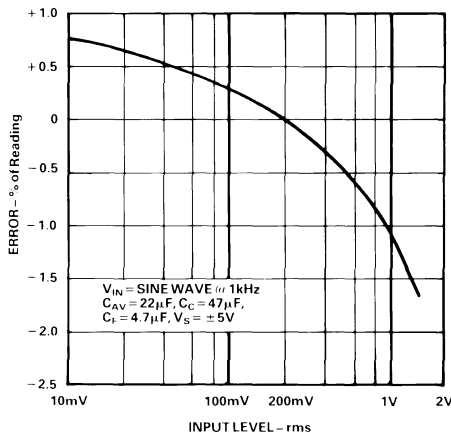

Figure 10. Error vs. RMS Input Voltage (Pin 2), Output Buffer Offset Is Adjusted To Zero

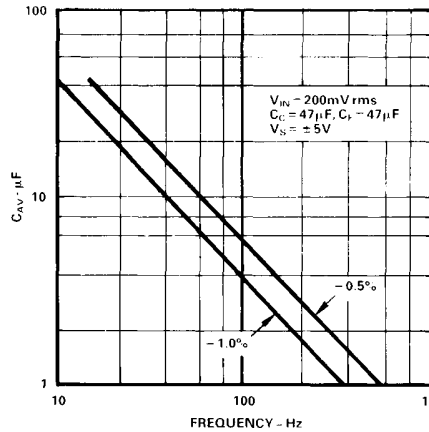

Figure 11. C_{AV} vs. Frequency for Specified Averaging Error

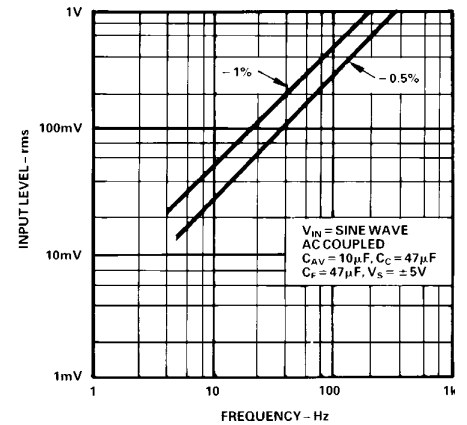

Figure 12. RMS Input Level vs. Frequency for Specified Averaging Error

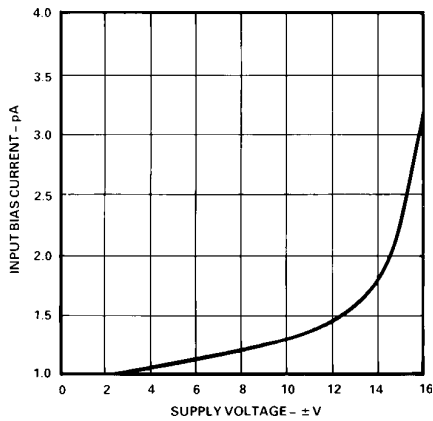

Figure 13. Pin 2 Input Bias Current vs. Supply Voltage

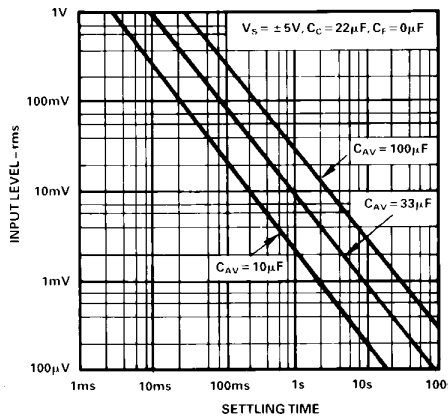

Figure 14. Settling Time vs. RMS Input Level for Various Values of C_{AV}

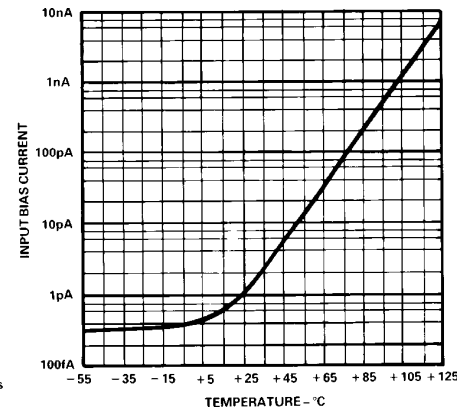

Figure 15. Pin 2 Input Bias Current vs. Temperature

CALCULATING SETTTLING TIME USING FIGURE 14

The graph of Figure 14 may be used to closely approximate the time required for the AD736 to settle when its input level is reduced in amplitude. The *net time* required for the rms converter to settle will be the *difference* between two times extracted from the graph – the initial time minus the final settling time. As an example, consider the following conditions: a 33 μF averaging capacitor, an initial rms input level of 100 mV and a final (reduced) input level of 1 mV. From Figure 14, the initial settling time (where the 100 mV line intersects the 33 μF line) is around 80 ms.

The settling time corresponding to the new or final input level of 1 mV is approximately 8 seconds. Therefore, the net time for the circuit to settle to its new value will be 8 seconds minus 80 ms which is 7.92 seconds. Note that, because of the smooth decay characteristic inherent with a capacitor/diode combination, this is the total settling time to the final value (i.e., *not* the settling time to 1%, 0.1%, etc., of final value). Also, this graph provides the worst case settling time, since the AD736 will settle very quickly with increasing input levels.

AD736

TYPES OF AC MEASUREMENT

The AD736 is capable of measuring ac signals by operating as either an average responding or a true rms-to-dc converter. As its name implies, an average responding converter computes the average absolute value of an ac (or ac and dc) voltage or current by full wave rectifying and low-pass filtering the input signal; this will approximate the average. The resulting output, a dc “average” level, is then scaled by adding (or reducing) gain; this scale factor converts the dc average reading to an rms equivalent value for the waveform being measured. For example, the average absolute value of a sine-wave voltage is 0.636 that of V_{PEAK} ; the corresponding rms value is 0.707 times V_{PEAK} . Therefore, for sine-wave voltages, the required scale factor is 1.11 (0.707 divided by 0.636).

In contrast to measuring the “average” value, true rms measurement is a “universal language” among waveforms, allowing the magnitudes of all types of voltage (or current) waveforms to be compared to one another and to dc. RMS is a direct measure of the power or heating value of an ac voltage compared to that of dc: an ac signal of 1 volt rms will produce the same amount of heat in a resistor as a 1 volt dc signal.

Mathematically, the rms value of a voltage is defined (using a simplified equation) as:

$$V_{rms} = \sqrt{Avg.(V^2)}$$

This involves squaring the signal, taking the average, and then obtaining the square root. True rms converters are “smart rectifiers”: they provide an accurate rms reading regardless of the type of waveform being measured. However, average responding converters can exhibit very high errors when their input signals deviate from their precalibrated waveform; the magnitude of the error will depend upon the type of waveform being measured. As an example, if an average responding converter is calibrated to measure the rms value of sine-wave voltages, and then is used to measure either symmetrical square waves or dc voltages, the converter will have a computational error 11% (of reading) higher than the true rms value (see Table I).

AD736 THEORY OF OPERATION

As shown by Figure 16, the AD736 has five functional subsec-

tions: input amplifier, full-wave rectifier, rms core, output amplifier and bias sections. The FET input amplifier allows both a high impedance, buffered input (Pin 2) or a low impedance, wide-dynamic-range input (Pin 1). The high impedance input, with its low input bias current, is well suited for use with high impedance input attenuators.

The output of the input amplifier drives a full wave precision rectifier, which in turn, drives the rms core. It is in the core that the essential rms operations of squaring, averaging and square rooting are performed, using an external averaging capacitor, C_{AV} . Without C_{AV} , the rectified input signal travels through the core unprocessed, as is done with the average responding connection (Figure 17).

A final subsection, an output amplifier, buffers the output from the core and also allows optional low-pass filtering to be performed via external capacitor, C_F , connected across the feedback path of the amplifier. In the average responding connection, this is where all of the averaging is carried out. In the rms circuit, this additional filtering stage helps reduce any output ripple which was not removed by the averaging capacitor, C_{AV} .

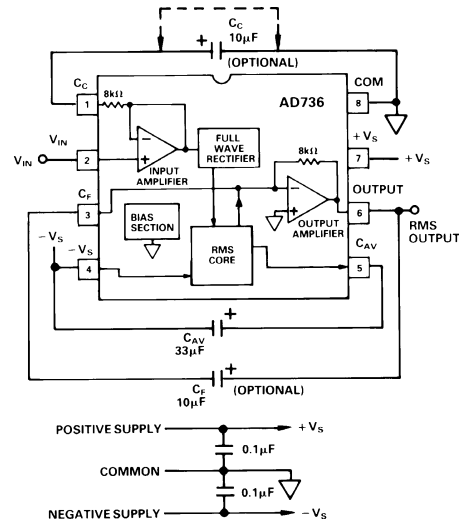

Figure 16. AD736 True RMS Circuit

Table I. Error Introduced by an Average Responding Circuit When Measuring Common Waveforms

Waveform Type 1 Volt Peak Amplitude	Crest Factor (V_{PEAK}/V_{rms})	True rms Value	Average Responding Circuit Calibrated to Read rms Value of Sine Waves Will Read	% of Reading Error* Using Average Responding Circuit
Undistorted Sine Wave	1.414	0.707 V	0.707 V	0%
Symmetrical Square Wave	1.00	1.00 V	1.11 V	+11.0%
Undistorted Triangle Wave	1.73	0.577 V	0.555 V	-3.8%
Gaussian Noise (98% of Peaks <1 V)	3	0.333 V	0.295 V	-11.4%
Rectangular Pulse Train	2 10	0.5 V 0.1 V	0.278 V 0.011 V	-44% -89%
SCR Waveforms 50% Duty Cycle 25% Duty Cycle	2 4.7	0.495 V 0.212 V	0.354 V 0.150 V	-28% -30%

$$*\% \text{ of Reading Error} = \frac{\text{Average Responding Value} - \text{True rms Value}}{\text{True rms Value}} \times 100\%$$

RMS MEASUREMENT - CHOOSING THE OPTIMUM VALUE FOR C_{AV}

Since the external averaging capacitor, C_{AV}, "holds" the rectified input signal during rms computation, its value directly affects the accuracy of the rms measurement, especially at low frequencies. Furthermore, because the averaging capacitor appears across a diode in the rms core, the averaging time constant will increase exponentially as the input signal is reduced. This means that as the input level decreases, errors due to nonideal averaging will *reduce* while the time it takes for the circuit to settle to the new rms level will *increase*. Therefore, lower input levels allow the circuit to perform better (due to increased averaging) but increase the waiting time between measurements. Obviously, when selecting C_{AV}, a trade-off between computational accuracy and settling time is required.

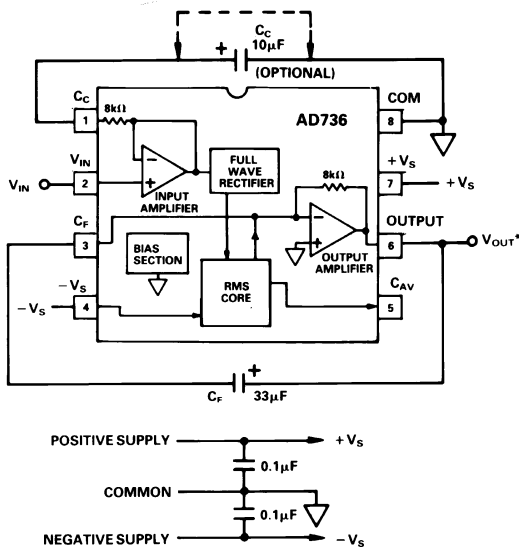

Figure 17. AD736 Average Responding Circuit

RAPID SETTLING TIMES VIA THE AVERAGE RESPONDING CONNECTION (FIGURE 17)

Because the average responding connection does not use the C_{AV} averaging capacitor, its settling time does not vary with input signal level; it is determined solely by the RC time constant of C_F and the internal 8 kΩ resistor in the output amplifier's feedback path.

DC ERROR, OUTPUT RIPPLE, AND AVERAGING ERROR

Figure 18 shows the typical output waveform of the AD736 with a sine-wave input applied. As with all real-world devices, the ideal output of V_{OUT} = V_{IN} is never exactly achieved; instead, the output contains both a dc and an ac error component.

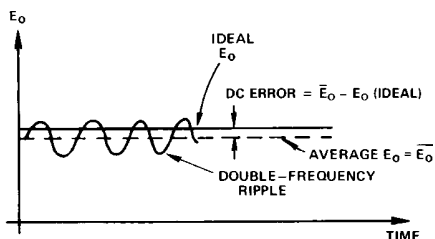

Figure 18. Output Waveform for Sine-Wave Input Voltage

As shown, the dc error is the difference between the average of the output signal (when all the ripple in the output has been removed by external filtering) and the ideal dc output. The dc error component is therefore set solely by the value of averaging capacitor used-no amount of post filtering (i.e., using a very large C_F) will allow the output voltage to equal its ideal value. The ac error component, an output ripple, may be easily removed by using a large enough post filtering capacitor, C_F.

In most cases, the combined magnitudes of both the dc and ac error components need to be considered when selecting appropriate values for capacitors C_{AV} and C_F. This combined error, representing the maximum uncertainty of the measurement is termed the "averaging error" and is equal to the peak value of the output ripple plus the dc error.

As the input frequency increases, both error components decrease rapidly: if the input frequency doubles, the dc error and ripple reduce to 1/4 and 1/2 their original values, respectively, and rapidly become insignificant.

AC MEASUREMENT ACCURACY AND CREST FACTOR

The crest factor of the input waveform is often overlooked when determining the accuracy of an ac measurement. Crest factor is defined as the ratio of the peak signal amplitude to the rms amplitude (C.F. = V_{PEAK}/V_{rms}). Many common waveforms, such as sine and triangle waves, have relatively low crest factors (≤2). Other waveforms, such as low duty cycle pulse trains and SCR waveforms, have high crest factors. These types of waveforms require a long averaging time constant (to average out the long time periods between pulses). Figure 6 shows the additional error vs. crest factor of the AD736 for various values of C_{AV}.

SELECTING PRACTICAL VALUES FOR INPUT COUPLING (C_C), AVERAGING (C_{AV}) AND FILTERING (C_F) CAPACITORS

Table II provides practical values of C_{AV} and C_F for several common applications.

Table II. AD737 Capacitor Selection Chart

Application	rms Input Level	Low Frequency Cutoff (-3dB)	Max Crest Factor	C _{AV}	C _F	Settling Time* to 1%	
General Purpose rms Computation	0-1 V	20 Hz	5	150 µF	10 µF	360 ms	
		200 Hz	5	15 µF	1 µF	36 ms	
	0-200 mV	20 Hz	5	33 µF	10 µF	360 ms	
		200 Hz	5	3.3 µF	1 µF	36 ms	
General Purpose Average Responding	0-1 V	20 Hz		None	33 µF	1.2 sec	
		200 Hz		None	3.3 µF	120 ms	
	0-200 mV	20 Hz		None	33 µF	1.2 sec	
		200 Hz		None	3.3 µF	120 ms	
SCR Waveform Measurement	0-200 mV	50 Hz	5	100 µF	33 µF	1.2 sec	
		60 Hz	5	82 µF	27 µF	1.0 sec	
	0-100 mV	50 Hz	5	50 µF	33 µF	1.2 sec	
		60 Hz	5	47 µF	27 µF	1.0 sec	
Audio Applications	0-200 mV	300 Hz	3	1.5 µF	0.5 µF	18 ms	
		0-100 mV	20 Hz	10	100 µF	68 µF	2.4 sec

*Settling time is specified over the stated rms input level with the input signal increasing from zero. Settling times will be greater for decreasing amplitude input signals.

AD736

The input coupling capacitor, C_C , in conjunction with the 8 kΩ internal input scaling resistor, determine the -3 dB low frequency rolloff. This frequency, F_L , is equal to:

$$F_L = \frac{1}{2\pi(8,000)(\text{The Value of } C_C \text{ in Farads})}$$

Note that at F_L , the amplitude error will be approximately -30% (-3 dB) of reading. To reduce this error to 0.5% of reading, choose a value of C_C that sets F_L at one tenth the lowest frequency to be measured.

In addition, if the input voltage has more than 100 mV of dc offset, than the ac coupling network shown in Figure 21 should be used in addition to capacitor C_C .

Applications Circuits

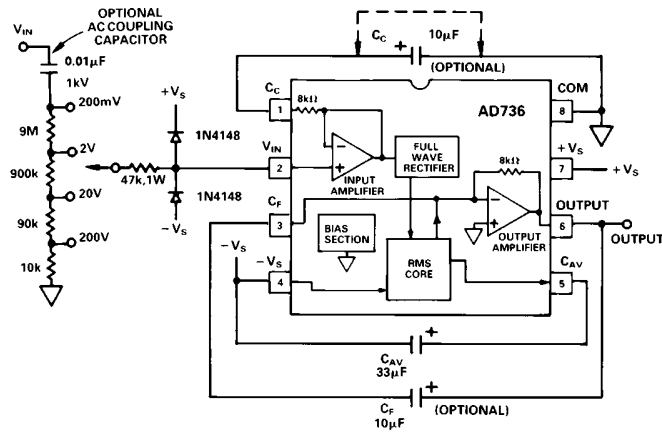

Figure 19. AD736 with a High Impedance Input Attenuator

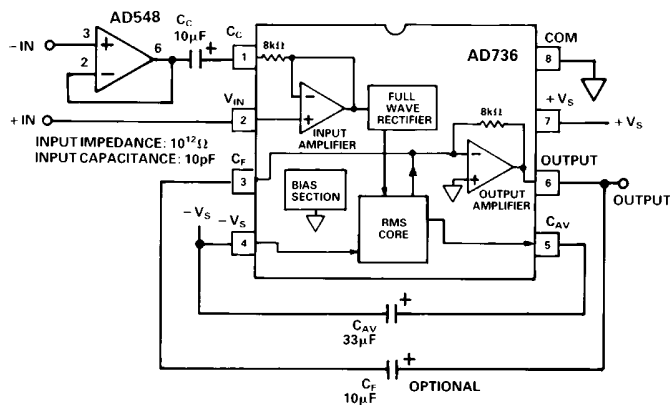

Figure 20. Differential Input Connection

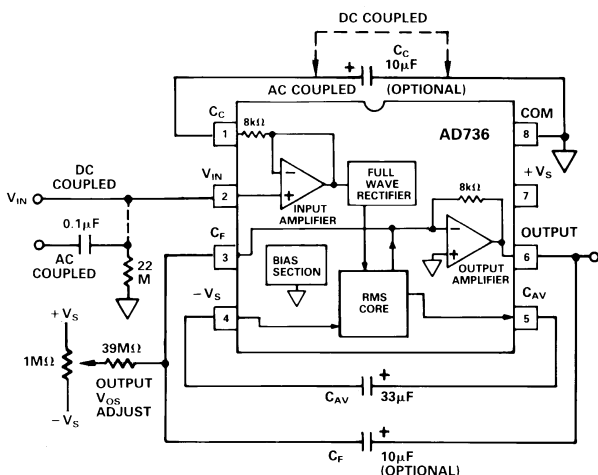

Figure 21. External Output V_{OS} Adjustment

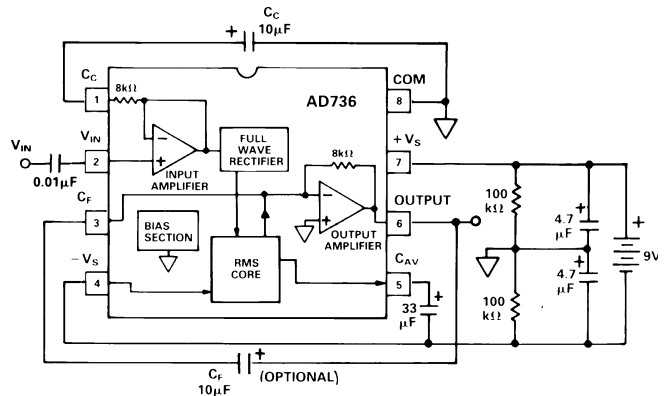

Figure 22. Battery Powered Option

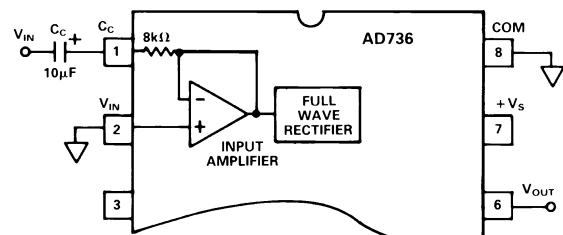

Figure 23. Low Z, AC Coupled Input Connection

OUTLINE DIMENSIONS

Dimensions shown in inches and (mm).

