

#### FEATURES

- Outstanding Gain Linearity
- Ultrahigh Gain 5000 V/mV Min
- Low  $V_{OS}$  Over Temperature 60  $\mu$ V Max
- Excellent  $TCV_{OS}$  0.3  $\mu$ V/ $^{\circ}$ C Max
- High PSRR 3  $\mu$ V/V Max
- Low Power Consumption 60 mW Max
- Fits OP07, 725, 108A/308A, 741 Sockets
- Available in Die Form

#### PIN CONNECTIONS

Epoxy Mini-Dip (P-Suffix)  
8-Pin Hermetic DIP

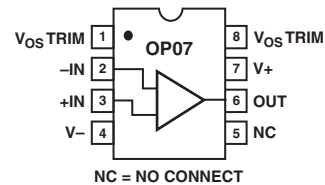

#### TO-99 (J-Suffix)

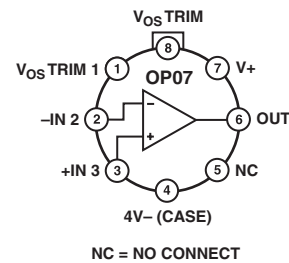

#### GENERAL DESCRIPTION

The OP77 significantly advances the state-of-the-art in precision op amps. The OP77's outstanding gain of 10,000,000 or more is maintained over the full 10 V output range. This exceptional gain-linearity eliminates incorrectable system nonlinearities common in previous monolithic op amps, and provides superior performance in high closed-loop gain applications. Low initial  $V_{OS}$  drift and rapid stabilization time, combined with only 50 mW power consumption, are significant improvements over previous designs. These characteristics, plus the exceptional  $TCV_{OS}$  of 0.3  $\mu$ V/ $^{\circ}$ C maximum and the low  $V_{OS}$  of 25  $\mu$ V maximum, eliminates the need for  $V_{OS}$  adjustment and increases system accuracy over temperature.

PSRR of 3  $\mu$ V/V (110 dB) and CMRR of 1.0  $\mu$ V/V maximum virtually eliminate errors caused by power supply drifts and common-mode signals. This combination of outstanding characteristics makes the OP77 ideally suited for high-resolution instrumentation and other tight error budget systems.

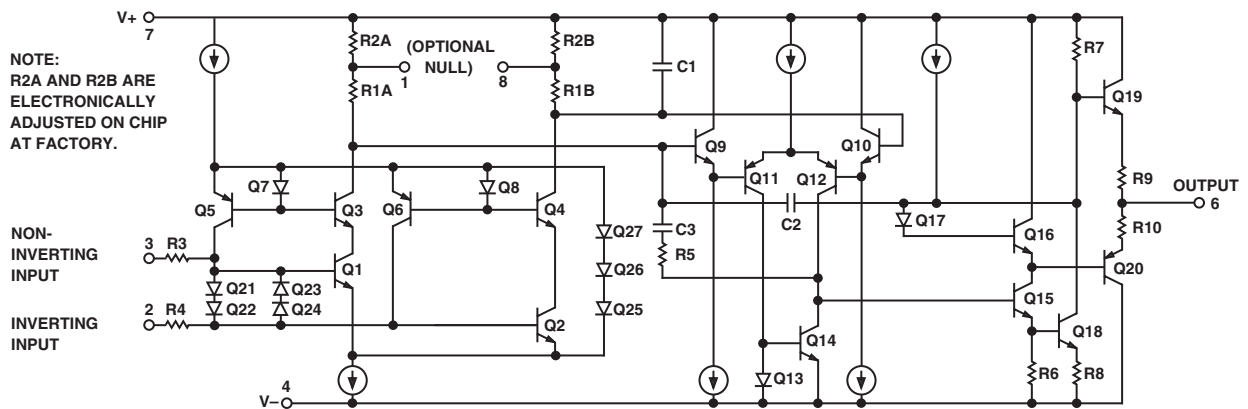

#### REV. B

Information furnished by Analog Devices is believed to be accurate and reliable. However, no responsibility is assumed by Analog Devices for its use, nor for any infringements of patents or other rights of third parties that may result from its use. No license is granted by implication or otherwise under any patent or patent rights of Analog Devices.

# OP77—SPECIFICATIONS

## ELECTRICAL SPECIFICATIONS (@ $V_S = \pm 15\text{ V}$ , $T_A = 25^\circ\text{C}$ , unless otherwise noted.)

Parameter	Symbol	Conditions	OP77A			Unit
			Min	Typ	Max	
INPUT OFFSET VOLTAGE	$V_{OS}$			10	25	$\mu\text{V}$
LONG-TERM INPUT OFFSET						
VOLTAGE STABILITY <sup>1</sup>	$DV_{OS}/\text{Time}$			0.2		$\mu\text{V}/\text{Mo}$
INPUT OFFSET CURRENT	$I_{OS}$			0.3		nA
INPUT BIAS CURRENT	$I_B$		-0.2	1.2	2.0	nA
INPUT NOISE VOLTAGE <sup>2</sup>	$e_{np-p}$	0.1 Hz to 10 Hz		0.35	0.6	$\mu\text{V p-p}$
INPUT NOISE VOLTAGE DENSITY <sup>2</sup>	$e_n$	$f_O = 10\text{ Hz}$ $f_O = 100\text{ Hz}$ $f_O = 1000\text{ Hz}$		10.3 10.0 9.6	18.0 13.0 11.0	V
INPUT NOISE CURRENT <sup>2</sup>	$i_{np-p}$	0.1 Hz to 10 Hz		14	30	pA p-p
INPUT NOISE CURRENT DENSITY <sup>2</sup>	$i_n$	$f_O = 10\text{ Hz}$ $f_O = 100\text{ Hz}$ $f_O = 1000\text{ Hz}$		0.32 0.14 0.12	0.80 0.23 0.17	pA/ $\sqrt{\text{Hz}}$
INPUT RESISTANCE Differential Mode <sup>3</sup> Common Mode	$R_{IN}$ $R_{INCM}$		26	45 200		MV GV
INPUT VOLTAGE RANGE	IVR		$\pm 13$	$\pm 14$		V
COMMON-MODE REJECTION RATIO	CMRR	$V_{CM} = \pm 13\text{ V}$		0.1	1.0	$\mu\text{V}/\text{V}$
POWER SUPPLY REJECTION RATIO	PSRR	$V_S = \pm 3\text{ V to } \pm 18\text{ V}$		0.7	3	$\mu\text{V}/\text{V}$
LARGE-SIGNAL VOLTAGE GAIN	$A_{VO}$	$R_L \geq 2\text{ k}\Omega \geq V_O = \pm 10\text{V}$	5000	12000		V/mV
OUTPUT VOLTAGE SWING	$V_O$	$R_L \geq 10\text{ k}\Omega$ $R_L \geq 2\text{ k}\Omega$ $R_L \geq 1\text{ k}\Omega$	$\pm 13.5$ $\pm 12.5$ $\pm 12.0$	$\pm 14.0$ $\pm 13.0$ $\pm 12.5$		V
SLEW RATE <sup>2</sup>	SR	$R_L \geq 2\text{ k}\Omega$	0.1	0.3		V/ $\mu\text{s}$
CLOSED-LOOP BANDWIDTH <sup>2</sup>	BW	$A_{VCL} = +1$	0.4	0.6		MHz
OPEN-LOOP OUTPUT RESISTANCE	$R_O$			60		$\Omega$
POWER CONSUMPTION	$P_d$	$V_S = \pm 15\text{ V, No Load}$ $V_S = \pm 3\text{ V, No Load}$		50 3.5	60 4.5	mW
OFFSET ADJUSTMENT RANGE		$R_P = 20\text{ k}\Omega$		$\pm 3$		mV

### NOTES

<sup>1</sup>Long-Term Input Offset Voltage Stability refers to the averaged trend line of  $V_{OS}$  vs. Time over extended periods after the first 30 days of operation. Excluding the initial hour of operation, changes in  $V_{OS}$  during the first 30 operating days are typically 2.5  $\mu\text{V}$ .

<sup>2</sup>Sample tested.

<sup>3</sup>Guaranteed by design.

# SPECIFICATIONS

## ELECTRICAL SPECIFICATIONS (@ $V_S = \pm 15\text{ V}$ , $-55^\circ\text{C} \leq T_A \leq 125^\circ\text{C}$ , unless otherwise noted.)

Parameter	Symbol	Conditions	Min	OP77A		Unit
				Typ	Max	
INPUT OFFSET VOLTAGE	$V_{OS}$			25	60	$\mu\text{V}$
AVERAGE INPUT OFFSET VOLTAGE DRIFT <sup>1</sup>	$TCV_{OS}$			0.1	0.3	$\mu\text{V}/^\circ\text{C}$
INPUT OFFSET CURRENT	$I_{OS}$			0.5	2.2	nA
AVERAGE INPUT OFFSET CURRENT DRIFT <sup>2</sup>	$TCI_{OS}$			1.5	25	$\text{pA}/^\circ\text{C}$
INPUT BIAS CURRENT	$I_B$		-0.2	2.4	4	nA
AVERAGE INPUT BIAS CURRENT DRIFT <sup>2</sup>	$TCI_B$			8	25	$\text{pA}/^\circ\text{C}$
INPUT VOLTAGE RANGE	IVR		$\pm 13$	$\pm 13.5$	0.6	V
COMMON-MODE REJECTION RATIO	CMRR	$V_{CM} = \pm 13\text{ V}$		0.1	1.0	$\mu\text{V}/\text{V}$
POWER SUPPLY REJECTION RATIO	PSRR	$V_S = \pm 3\text{ V to } \pm 18\text{ V}$		1	3	$\mu\text{V}/\text{V}$
LARGE-SIGNAL VOLTAGE GAIN	$A_{VO}$	$R_L \geq 2\text{ k}\Omega \geq V_O = \pm 10\text{ V}$	2000	6000		V/mV
OUTPUT VOLTAGE SWING	$V_O$	$R_L \geq 10\text{ k}\Omega$	$\pm 12$	$\pm 13.0$		V
POWER CONSUMPTION	$P_d$	$V_S = \pm 15\text{ V}$ , No Load		60	75	mW

## NOTES

<sup>1</sup>OP77A:  $TCV_{CS}$  is 100% tested.<sup>2</sup>Guaranteed by design.

# OP77—SPECIFICATIONS

## ELECTRICAL CHARACTERISTICS (@ $V_S = \pm 15\text{ V}$ , $T_A = 125^\circ\text{C}$ , unless otherwise noted.)

Parameter	Symbol	Conditions	OP77E			OP77F			Unit
			Min	Typ	Max	Min	Typ	Max	
INPUT OFFSET VOLTAGE	VOS		10	25		20	60	$\mu\text{V}$	
LONG-TERM STABILITY <sup>1</sup>	$V_{OS}/\text{Time}$		0.3			0.4		$\mu\text{V}/\text{Mo}$	
INPUT OFFSET CURRENT	$I_{OS}$		0.3	1.5		0.3	2.8	nA	
INPUT BIAS CURRENT	$I_B$		-0.2	1.2	2.0	-0.2	1.2	2.8	nA
INPUT NOISE VOLTAGE <sup>2</sup>	$\epsilon_{np-p}$	0.1 Hz to 10 Hz	0.35	0.6		0.38	0.65	$\mu\text{V}_{p-p}$	
INPUT NOISE VOLTAGE DENSITY	$\epsilon_n$	$f_O = 10\text{ Hz}$ $f_O = 100\text{ Hz}^2$ $f_O = 1000\text{ Hz}$	10.3 10.0 9.6	18.0 13.0 11.0		10.5 10.2 9.8	20.0 13.5 11.5	nV/X/i	
INPUT NOISE CURRENT <sup>2</sup>	$i_{np-p}$	0.1 Hz to 10 Hz	14	30		15	35	$\text{pA}_{p-p}$	
INPUT NOISE CURRENT DENSITY	$i_n$	$f_O = 10\text{ Hz}$ $f_O = 100\text{ Hz}^2$ $f_O = 1000\text{ Hz}$	0.32 0.14 0.12	0.80 0.23 0.17		0.35 0.15 0.13	0.90 0.27 0.18	$\text{pA}\sqrt{\text{Hz}}$	
INPUT RESISTANCE Differential Mode <sup>3</sup> Common Mode	$R_{IN}$ $R_{INCM}$		26	45 200		18.5	45 200	M $\Omega$ G $\Omega$	
INPUT RESISTANCE Common Mode	$R_{INCM}$		200			200		G $\Omega$	
INPUT VOLTAGE RANGE	IVR		$\pm 13$	$\pm 14$		$\pm 13$	$\pm 14$	V	
COMMON-MODE REJECTION RATIO	CMRR	$V_{CM} = \pm 13\text{ V}$	0.1	1.0		0.1	1.6	$\mu\text{V}/\text{V}$	
POWER SUPPLY REJECTION RATIO	PSRR	$V_S = 3\text{ V to }18\text{ V}$	0.7	3.0		0.7	3.0	$\mu\text{V}/\text{V}$	
LARGE-SIGNAL VOLTAGE GAIN	$A_{VO}$	$R_L \geq 2\text{ k}\Omega$	5000	12000		2000	6000	V/mV	
OUTPUT VOLTAGE SWING	$V_O$	$R_L \geq 10\text{ k}\Omega$ $R_L \geq 2\text{ k}\Omega$ $R_L \geq 1\text{ k}\Omega$	$\pm 13.5$ $\pm 12.5$ $\pm 12.0$	$\pm 14.0$ $\pm 13.0$ $\pm 12.5$		$\pm 13.5$ $\pm 12.5$ $\pm 12.0$	$\pm 14.0$ $\pm 13.0$ $\pm 12.5$	V	
SLEW RATE <sup>2</sup>	SR	$R_L \geq 2\text{ k}\Omega$	0.1	0.3		0.1	0.3	V/ $\mu\text{s}$	
CLOSED-LOOP BANDWIDTH <sup>2</sup>	BW	$A_{VCL} 1$	0.4	0.6		0.4	0.6	MHz	
OPEN-LOOP OUTPUT RESISTANCE	$R_O$		60			60		$\Omega$	
POWER CONSUMPTION	$P_d$	$V_S = \pm 15\text{ V}$ , No Load $V_S = \pm 3\text{ V}$ , No Load	50 3.5	60 4.5		50 3.5	60 4.5	mW	
OFFSET ADJUSTMENT RANGE		$R_p = 20\text{ kn}$		$\pm 3$			$\pm 3$	mV	

### NOTES

<sup>1</sup>Long-Term Input Offset Voltage Stability refers to the averaged trend line of  $V_{OS}$  vs. Time over extended periods after the first 30 days of operation. Excluding the initial hour of operation, changes in  $V_{OS}$  during the first 30 operating days are typically  $2.5\ \mu\text{V}$ .

<sup>2</sup>Sample tested.

<sup>3</sup>Guaranteed by design.

# SPECIFICATIONS

## ELECTRICAL CHARACTERISTICS (@ $V_S = \pm 15\text{ V}$ , $-25^\circ\text{C} \leq T_A \leq +85^\circ\text{C}$ for OP77E/FJ and OP77E/FZ, unless otherwise noted.)

Parameter	Symbol	Conditions	OP77E			OP77F			Unit
			Min	Typ	Max	Min	Typ	Max	
INPUT OFFSET VOLTAGE	V	J, Z Packages	10	45		20	100		$\mu\text{V}$
			10	55		20	100		
AVERAGE INPUT OFFSET VOLTAGE DRIFT <sup>1</sup>	$\text{TCV}_{\text{OS}}$	J, Z Packages	0.1	0.3		0.2	0.6		$\mu\text{V}/^\circ\text{C}$
			0.3	0.6		0.4	1.0		
INPUT OFFSET CURRENT	$\text{I}_{\text{OS}}$		0.5	2.2		0.5	4.5		nA
AVERAGE INPUT OFFSET CURRENT DRIFT <sup>2</sup>	$\text{TCI}_{\text{OS}}$		1.5	4.0		1.5	85		$\text{pA}/^\circ\text{C}$
INPUT BIAS CURRENT	$\text{I}_{\text{B}}$	E, F	-0.2	2.4	4.0	-0.2	2.4	6.0	nA
AVERAGE INPUT BIAS CURRENT DRIFT <sup>2</sup>	$\text{TCI}_{\text{B}}$		8	40		15	60		$\text{pA}/^\circ\text{C}$
INPUT VOLTAGE RANGE	IVR		$\pm 13.0$	$\pm 13.5$		$\pm 13.0$	$\pm 13.5$		V
COMMON-MODE REJECTION RATIO	CMRR	$V_{\text{CM}} = \pm 13\text{ V}$	0.1	1.0		0.1	3.0		pV/V
POWER SUPPLY REJECTION RATIO	PSRR	$V_S = \pm 3\text{ V to } \pm 18\text{ V}$	1.0	3.0		1.0	5.0		$\mu\text{V}/\text{V}$
LARGE-SIGNAL VOLTAGE GAIN	$A_{\text{VO}}$	$R_L \geq 2\text{ k}\Omega$ $V_O = \pm 10\text{ V}$	2000	6000		1000	4000		V/mV
OUTPUT VOLTAGE SWING	$V_O$	$R_L \geq 2\text{ k}\Omega$	$\pm 12$	$\pm 13.0$		$\pm 12$	$\pm 13.0$		V
POWER CONSUMPTION	$P_d$	$V_S = \pm 15\text{ V}$ , No Load	60	75		60	75		mW

NOTES

<sup>1</sup>OP77E:  $\text{TCV}_{\text{OS}}$  is 100% tested on J and Z packages.

<sup>2</sup>Guaranteed by end-point limits.

# OP77—SPECIFICATIONS

## WAFER TEST LIMITS (@ $V_s = \pm 15\text{ V}$ , $T_A = 25^\circ\text{C}$ , for OP77N devices, unless otherwise noted.)

Parameter	Symbol	Conditions	OP77N Limit	Unit
INPUT OFFSET VOLTAGE	$V_{OS}$		40	$\mu\text{V}$ Max
INPUT OFFSET CURRENT	$I_{OS}$		2.0	nA Max
INPUT BIAS CURRENT	$I_B$		$\pm 2$	nA Max
INPUT RESISTANCE Differential Mode	$R_{IN}$		26	M $\Omega$ Min
INPUT VOLTAGE RANGE	IVR		$\pm 13$	V Min
COMMON-MODE REJECTION RATIO	CMRR	$V_{CM} = \pm 13\text{ V}$	1	$\mu\text{V}/\text{V}$ Max
POWER SUPPLY REJECTION RATIO	PSRR	$V_S = \pm 3\text{ V}$ to $\pm 18\text{ V}$	3	$\mu\text{V}/\text{VMax}$
OUTPUT VOLTAGE SWING	$V_O$	$R_L = 10\text{ k}\Omega$ $R_L = 2\text{ k}\Omega$ $R_L = 1\text{ k}\Omega$	$\pm 13.5$ $\pm 12.5$ $\pm 12.0$	V Min
LARGE-SIGNAL VOLTAGE GAIN	$A_{VO}$	$R_L = 2\text{ k}\Omega$ $V_O = \pm 10\text{ V}$	2000	V/mV Min
DIFFERENTIAL INPUT VOLTAGE			$\pm 30$	V Max
POWER CONSUMPTION	$P_d$	$V_{OUT} = 0\text{ V}$	60	mW Max

### NOTES

<sup>1</sup>Guaranteed by design.

<sup>2</sup>Electrical tests are performed at wafer probe to the limits shown. Due to variations in assembly methods and normal yield loss, yield after packaging is not guaranteed for standard product dice. Consult factory to negotiate specifications based on dice lot qualification through sample lot assembly and testing.

## TYPICAL ELECTRICAL CHARACTERISTICS (@ $V_s = \pm 15\text{ V}$ , $T_A = 25^\circ\text{C}$ , unless otherwise noted.)

Parameter	Symbol	Conditions	OP77N Limit	Unit
AVERAGE INPUT OFFSET VOLTAGE DRIFT	$TCV_{OS}$	$R_S = 50\ \Omega$	0.1	$\mu\text{V}/\text{OC}$
NULLED INPUT OFFSET VOLTAGE DRIFT	$TCV_{OSn}$	$R_S = 50\ \Omega$ , $R_P = 20\text{ k}\Omega$	0.1	$\mu\text{V}/^\circ\text{C}$
AVERAGE INPUT OFFSET CURRENT DRIFT	$TCI_{OS}$		0.5	pA/ $^\circ\text{C}$
SLEW RATE	SR	$R_L \geq 2\text{ k}\Omega$	0.3	V/ $\mu\text{s}$
BANDWIDTH	BW	$A_{VCL} + 1$	0.6	MHz

## ABSOLUTE MAXIMUM RATINGS<sup>1</sup>

Supply Voltage . . . . .	±22 V
Differential Input Voltage . . . . .	±30 V
Input Voltage <sup>2</sup> . . . . .	±22 V
Output Short-Circuit Duration . . . . .	Indefinite
Storage Temperature Range	
J and Z Packages . . . . .	−65°C to +150°C
Operating Temperature Range	
OP77A . . . . .	−55°C to +125°C
OP77E, OPP77F (J, Z) . . . . .	−25°C to +85°C
Junction Temperature (T <sub>j</sub> ) . . . . .	−65°C to +150°C
Lead Temperature (Soldering, 60 sec.) . . . . .	300°C

### NOTES

<sup>1</sup>Absolute Maximum Ratings apply to both DICE and packaged parts, unless otherwise noted.

<sup>2</sup>For supply voltages less than ±22 V, the absolute maximum input voltage is equal to the supply voltage.

Package Type	θ <sub>JA</sub> <sup>*</sup>	θ <sub>JC</sub>	Unit
TO-99 (J)	150	18	°C/W
8-Lead Hermetic DIP (Z)	148	16	°C/W

### NOTE

<sup>\*</sup>θ<sub>JA</sub> is specified for worst-case mounting conditions, i.e., θ<sub>JA</sub> is specified for device in socket for TO, Cerdip, P-DIP, and PLCC packages; θ<sub>JA</sub> is specified for device soldered to printed circuit board for SO package.

## BONDING DIAGRAM

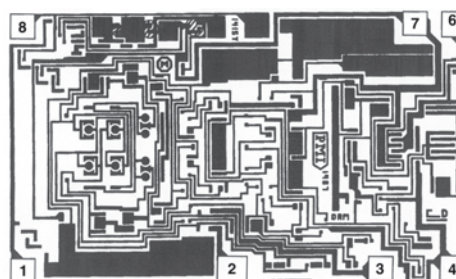

1. BALANCE
2. INVERTING INPUT
3. NONINVERTING INPUT
4. V-
5. V+
6. OUTPUT
7. V+
8. BALANCE

DIE SIZE 0.093 × 0.057 inch, 5301 sq. mm  
(2.36 × 1.45 mm, 3.42 sq. mm)

## ORDERING GUIDE

TO-99	Package Options	Operating Temperature Range
	CERDIP* 8-Lead	
OP77EJ	OP77AZ	MIL
OP77FJ	OP77EZ	IND
	OP77FZ	IND

\*Not for new designs; obsolete April 2002.

For Military processed devices, please refer to the Standard Microcircuit Drawing (SMD) available at [www.dsc.dla.mil/programs/milspec/default.asp](http://www.dsc.dla.mil/programs/milspec/default.asp)

SMD Part Number	ADI Equivalent
5962-87738012A	OP77BRCMDA
5962-8773802GA	OP77AJMDA
5962-8773802PA	OP77AZMDA

## CAUTION

ESD (electrostatic discharge) sensitive device. Electrostatic charges as high as 4000 V readily accumulate on the human body and test equipment and can discharge without detection. Although the OP77 features proprietary ESD protection circuitry, permanent damage may occur on devices subjected to high-energy electrostatic discharges. Therefore, proper ESD precautions are recommended to avoid performance degradation or loss of functionality.



# OP77-Typical Performance Characteristics

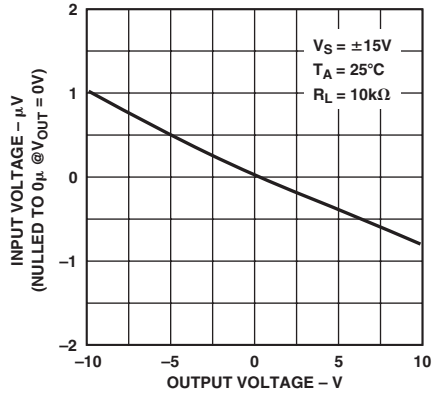

TPC 1. Gain Linearity (Input Voltage vs. Output Voltage)

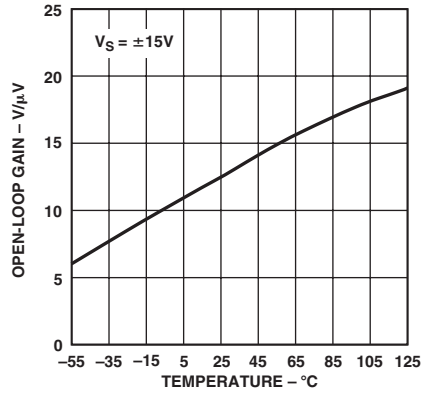

TPC 2. Open-Loop Gain vs. Temperature

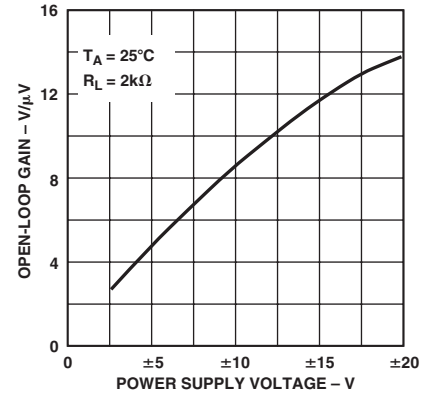

TPC 3. Open-Loop Gain vs. Power Supply Voltage

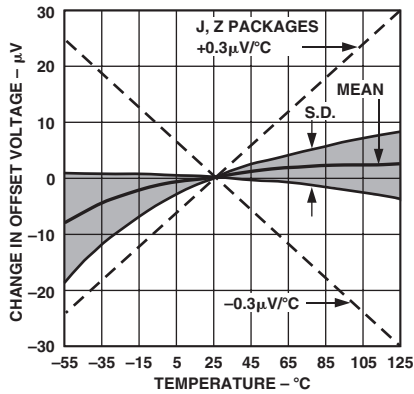

TPC 4. Untrimmed Offset Voltage vs. Temperature

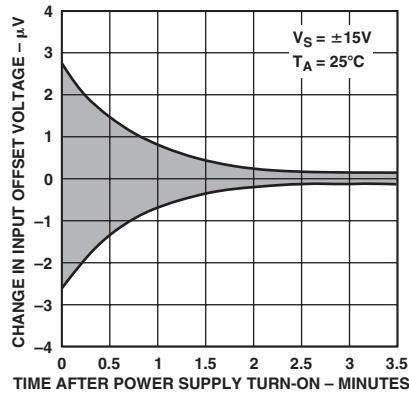

TPC 5. Warm-Up Drift

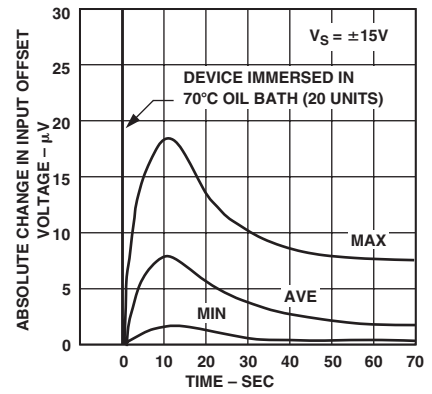

TPC 6. Offset Voltage Change Due to Thermal Shock

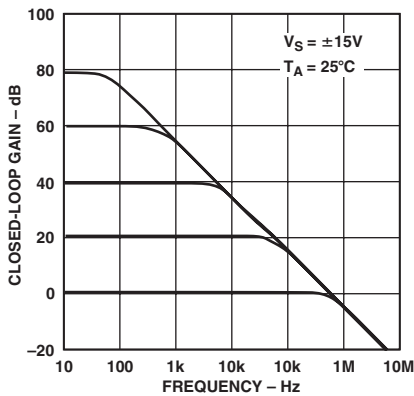

TPC 7. Closed-Loop Response for Various Gain Configurations

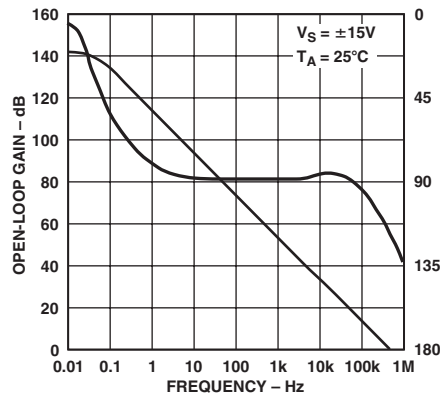

TPC 8. Open-Loop Gain/Phase Response

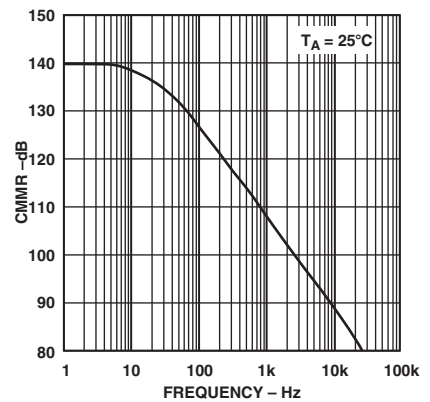

TPC 9. CMRR vs. Frequency



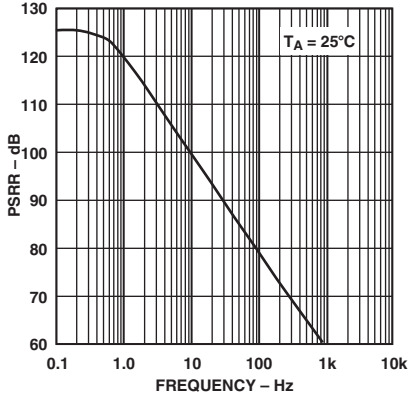

TPC 10. PSRR vs. Frequency

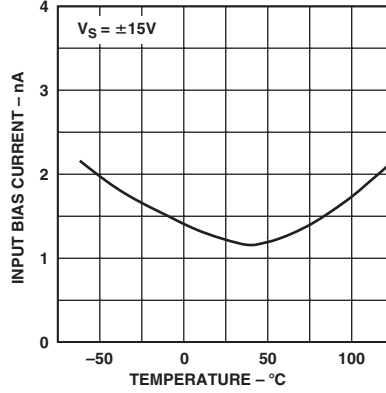

TPC 11. Input Bias Current vs. Temperature

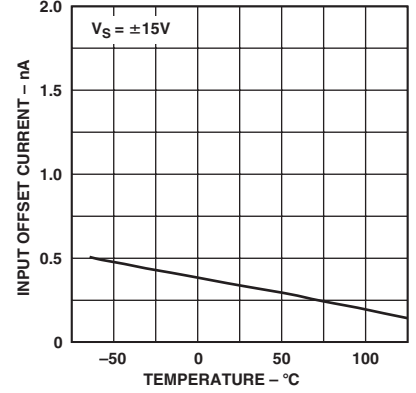

TPC 12. Input Offset Current vs. Temperature

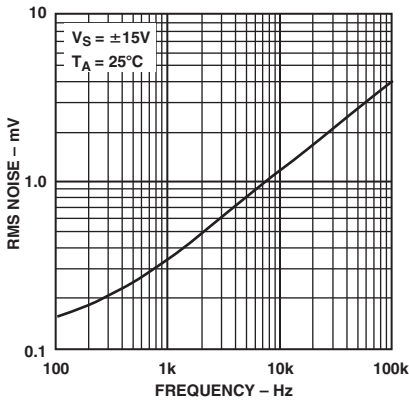

TPC 13. Input Wideband Noise vs. Bandwidth (0.1 Hz to Frequency Indicated)

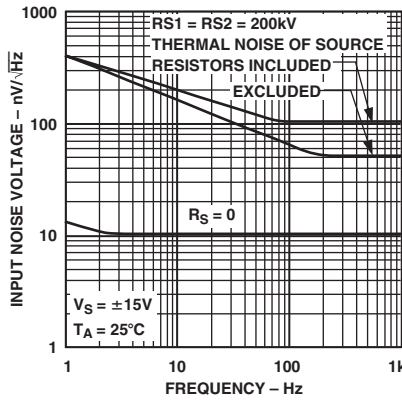

TPC 14. Total Input Noise Voltage vs. Frequency

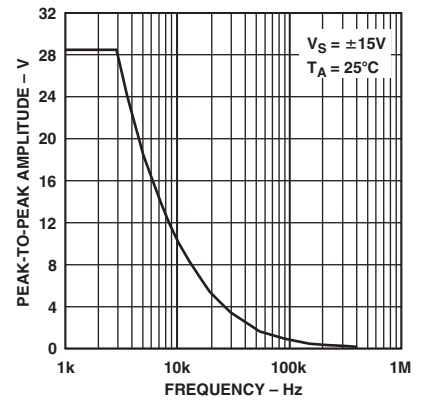

TPC 15. Maximum Output Swing vs. Frequency

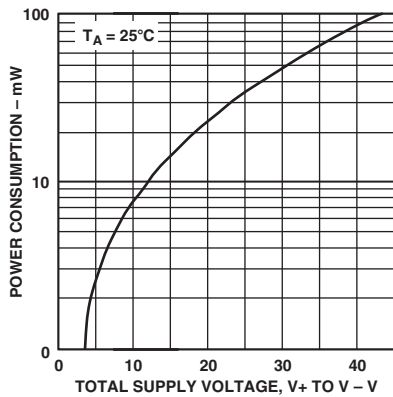

TPC 16. Power Consumption vs. Power Supply

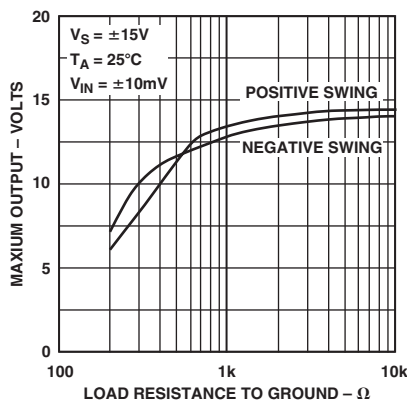

TPC 17. Maximum Output Voltage vs. Load Resistance

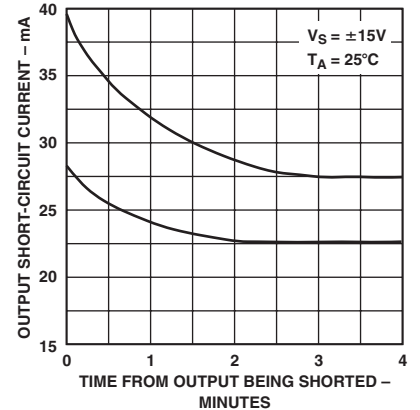

TPC 18. Output Short-Circuit Current vs. Time

# OP77

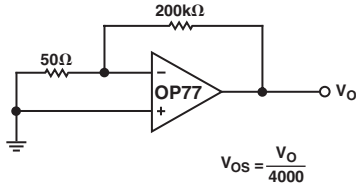

Figure 1. Typical Offset Voltage Test Circuit

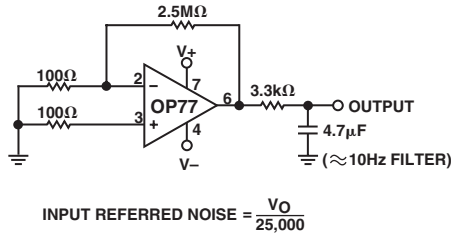

Figure 2. Optional Offset Nulling Circuit

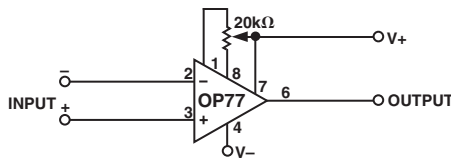

Figure 3. Typical Low-Frequency Noise Test Circuit

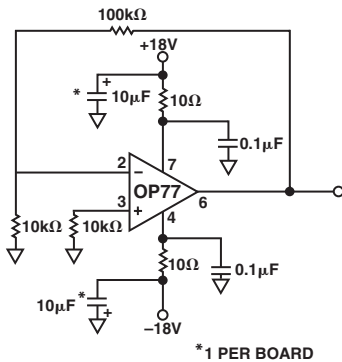
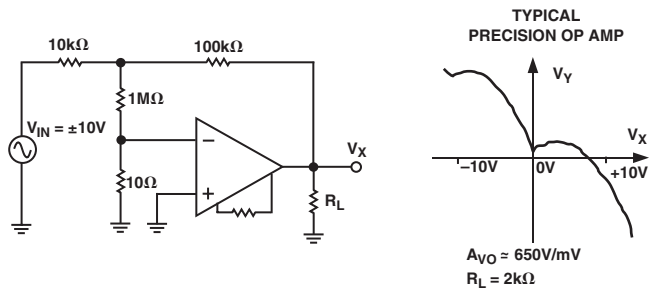

Figure 4. Burn-In Circuit



**NOTES**

1. GAIN NOT CONSTANT. CAUSES NONLINEAR ERRORS.
2. A<sub>VO</sub> SPEC IS ONLY PART OF THE SOLUTION.
3. CHECK THE OP AMP PERFORMANCE, ESPECIALLY AT TEMPERATURES.

Figure 5. Open-Loop Gain Linearity

Actual open-loop voltage gain can vary greatly at various output voltages. All automated testers use endpoint testing and therefore only show the average gain. This causes errors in high closed-loop gain circuits. Since this is so difficult for manufacturers to test, users should make their own evaluation. This simple test circuit makes it easy. An ideal op amp would show a horizontal scope trace.

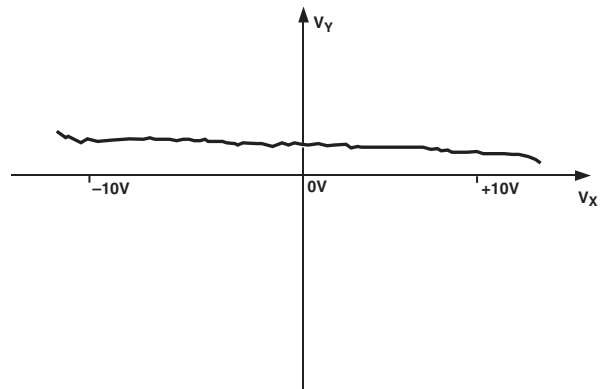

Figure 6. Output Gain Linearity Trace

This is the output gain linearity trace for the new OP77. The output trace is virtually horizontal at all points, assuring extremely high gain accuracy. The average open-loop gain is truly impressive—approximately 10,000,000.

APPLICATIONS INFORMATION

Bilateral Current Source

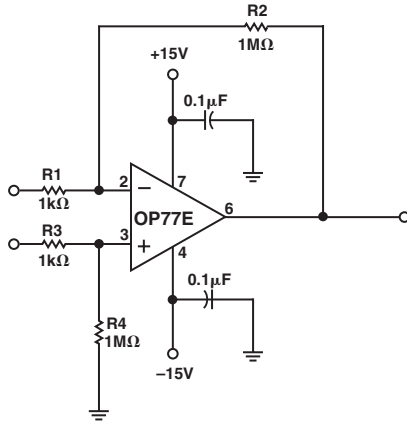

Figure 7. Precision High-Gain Differential Amplifier

The high gain, gain linearity, CMRR, and low TCVs of the OP77 make it possible to obtain performance not previously available in single-stage very high-gain amplifier applications.

For best CMR,  $\frac{R1}{R2}$  must equal  $\frac{R3}{R4}$ . In this example,

with a 10 mV differential signal, the maximum errors are as listed in Table I.

Table I. Maximum Errors

TYPE	AMOUNT
COMMON-MODE VOLTAGE	0.01%/V
GAIN LINEARITY, WORST CASE	0.02%
TCVOS	0.003%/°C
TCIOS	0.008%/°C

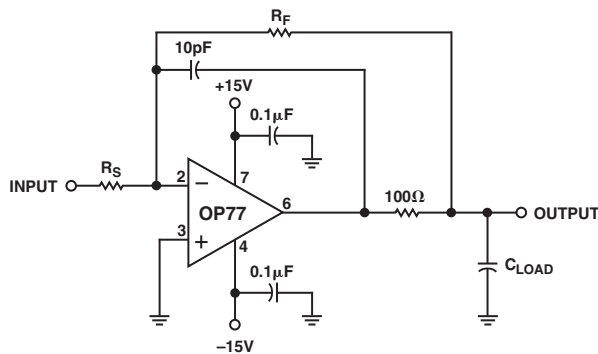

Figure 8. Isolating Large Capacitive Loads

This circuit reduces maximum slew-rate but allows driving capacitive loads of any size without instability. Because the boom resistor is inside the feedback loop, its effect on output impedance is reduced to insignificance by the high open-loop gain of the OP77.

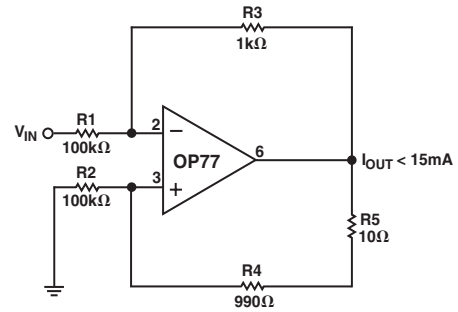

Figure 9. Basic Current Source

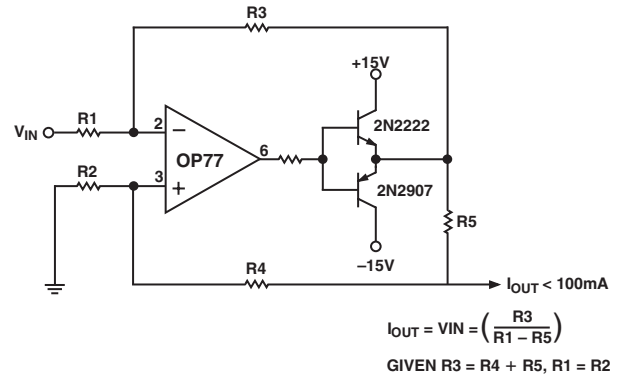

Figure 10. 100 mA Current Source

These current sources will supply both positive and negative current into a grounded load.

Note that  $Z_O = \frac{R5 \left( \frac{R4}{R2} + 1 \right)}{R5 + R4} \frac{R3}{R1}$

and that for  $Z_O$  to be infinite,

# OP77

$$\frac{R5 + R4}{R2} \text{ must} = \frac{R3}{R1}$$

## Precision Current Sinks

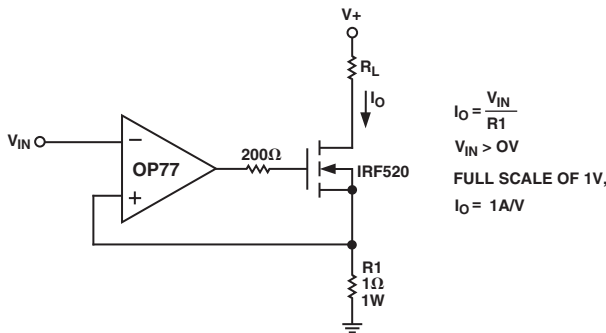

Figure 11. Positive Current Sink

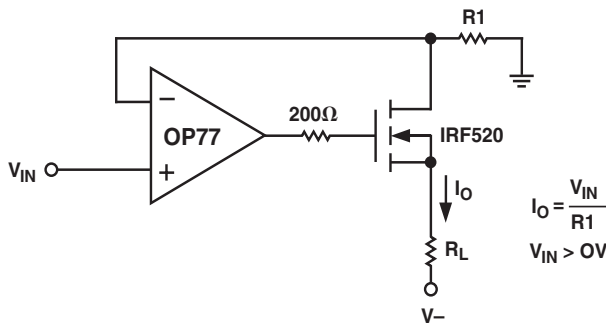

Figure 12. Positive Current Source

These simple high-current sinks require the load to float between the power supply and the sink.

In these circuits, OP77's high gain, high CMRR, and low  $TCV_{OS}$  ensure high accuracy.

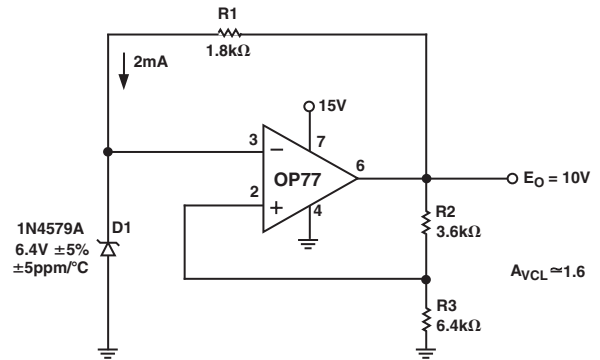

Figure 13. High Stability Voltage Reference

This simple bootstrapped voltage reference provides a precise 10 V virtually independent of changes in power supply voltage, ambient temperature and output loading. Correct Zener operating current of exactly 2 mA is maintained by R1, a selected 5 ppm/°C resistor, connected to the regulated output. Accuracy is primarily determined by three factors: the 5 ppm/°C temperature coefficient of D1, 1 ppm/°C ratio tracking of R2 and R3, and operational amplifier  $V_{OS}$  errors.

$V_{OS}$  errors, amplified by 1.6 ( $A_{VCL}$ ), appear at the output and can be significant with most monolithic amplifiers. For example, an ordinary amplifier with  $TCV_{OS}$  of 5  $\mu V/^\circ C$  contributes 0.8 ppm/°C of output error while the OP77, with  $TCV_{OS}$  of 0.3  $\mu V/^\circ C$ , contributes but 0.05 ppm/°C of output error, thus effectively eliminating  $TCV_{OS}$  as an error consideration.

The high gain and low  $TCV_{OS}$  assure accurate operation with inputs from microvolts to volts. In this circuit, the signal always

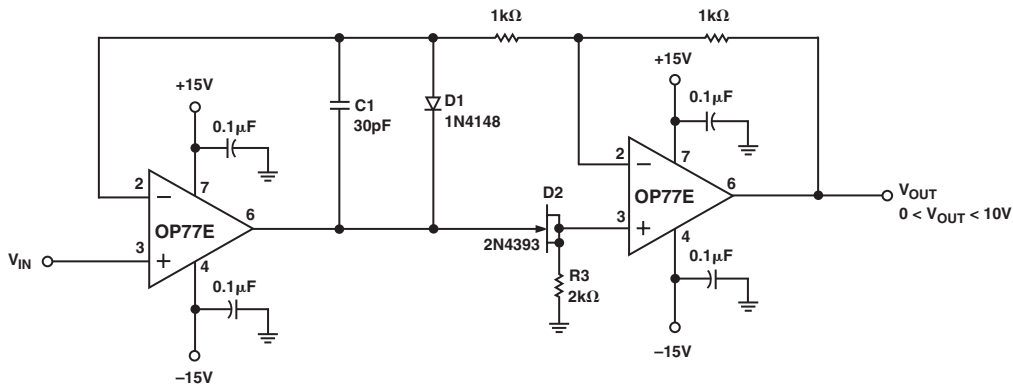

Figure 14. Precision Absolute Value Amplifier

The high gain and low  $TCV_{OS}$  assure accurate operation with inputs from microvolts to volts. In this circuit, the signal always

appears as a common-mode signal to the op amps. The OP77E CMRR of 1  $\mu V/V$  assures errors of less than 2 ppm.

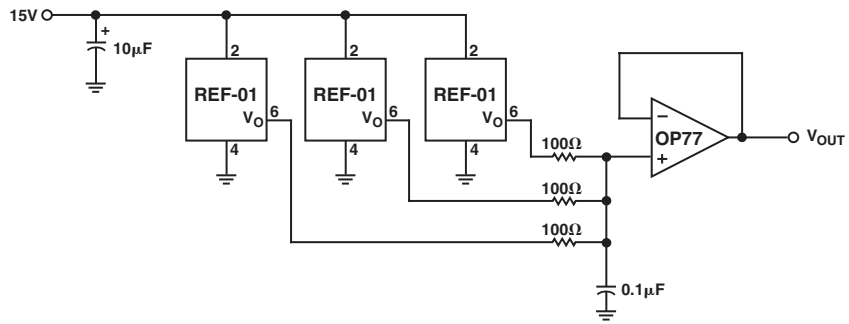

Figure 15. Low Noise Precision Reference

This circuit relies upon OP77's low  $TCV_{OS}$  and noise combined with very high CMRR to provide precision buffering of the averaged REF01 voltage outputs.

$C_H$  must be of polystyrene, Teflon\*, or polyethylene to minimize dielectric absorption and leakage. The droop rate is determined by the size of  $C_H$  and the bias current of the AD820.

\*Teflon is a registered trademark of the Dupont Company

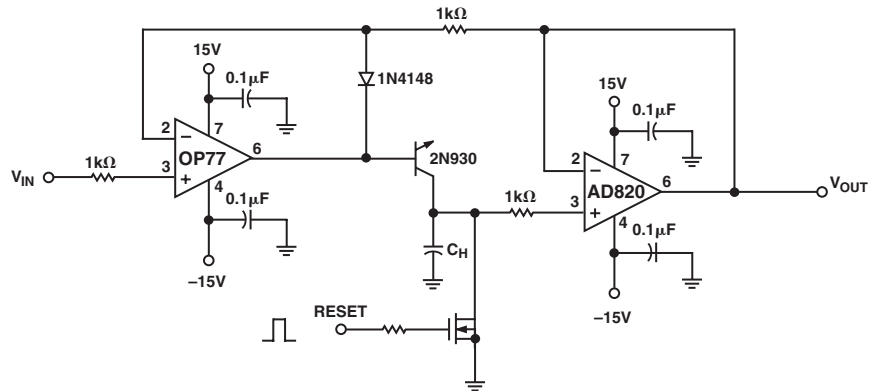

Figure 16. Precision Positive Peak Detector

# OP77

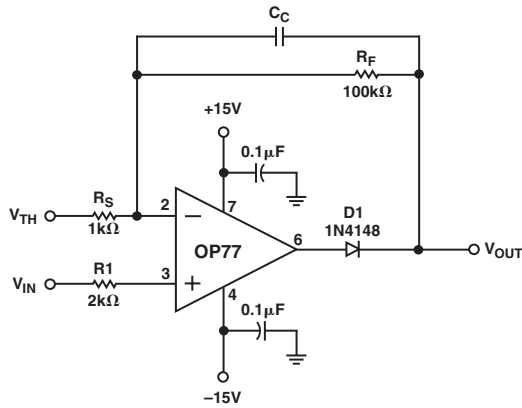

Figure 17. Precision Threshold Detector/Amplifier

When  $V_{IN} < V_{TH}$ , amplifier output swings negative, reverse biasing diode D1.  $V_{OUT} = V_{TH}$  if  $R_L = \infty$  when  $V_{IN} > V_{TH}$ , the loop closes,

$$V_{OUT} = V_{TH} + (V_{IN} - V_{TH}) \left( 1 + \frac{R_F}{R_S} \right)$$

$C_C$  is selected to smooth the response of the loop.

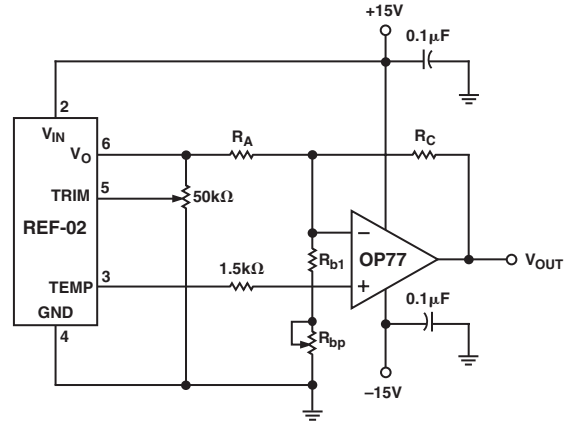

Figure 18. Precision Temperature Sensor

Table II. Resistor Values

TCV <sub>OUT</sub> SLOPE (S)	10 mV/°C	100 mV/°C	10 mV/°F
TEMPERATURE RANGE	-55°C to +125°C	-55°C to +125°C	-67°F to +257°C
OUTPUT VOLTAGE RANGE	-0.55 V to +1.25 V	-5.5 V to +12.5V	-0.67 V to +2.57V
ZERO-SCALE	0 V @ 0°C	0 V @ 0°C	0 V @ 0°F
R <sub>a</sub> (±1% Resistor)	9.09 kΩ	15 kΩ	7.5 kΩ
R <sub>b1</sub> (±1% Resistor)	1.5 kΩ	1.82 kΩ	1.21 kΩ
R <sub>bp</sub> (Potentiometer)	200 Ω	500 Ω	200 Ω
R <sub>c</sub> (±1% Resistor)	5.11 kΩ	84.5 kΩ	8.25 kΩ

OUTLINE DIMENSIONS

Dimensions shown in inches and (mm).

8-Lead Plastic DIP

(N-8)

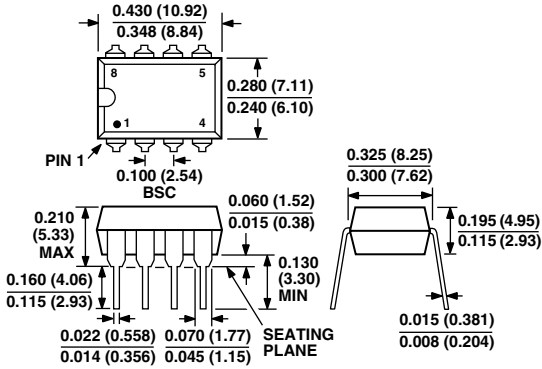

8-Lead Hermetic

(Q-8)

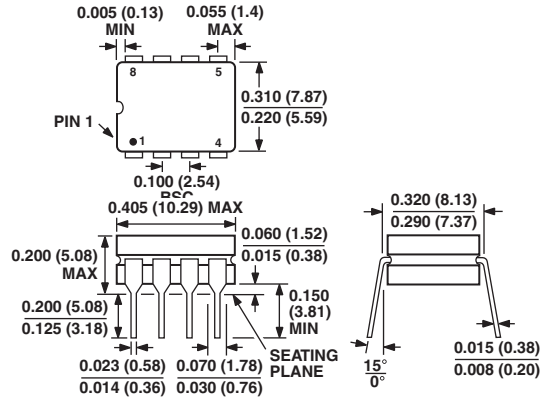

8-Lead PLCC

(P-20A)

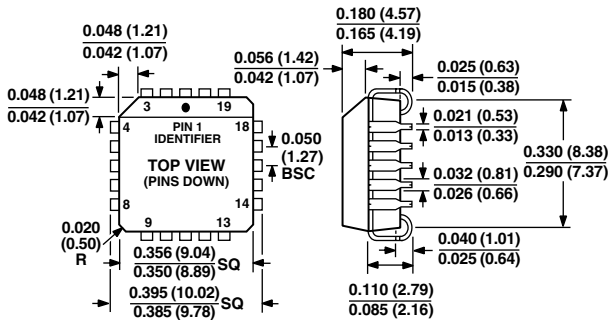

8-Lead Header Package

(H-8)

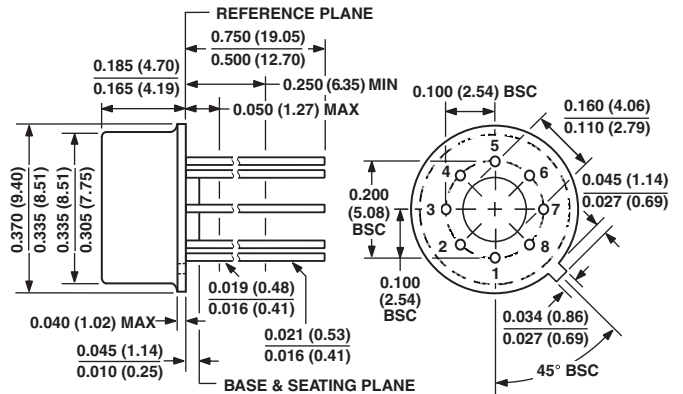

Revision History

Location	Page
Data Sheet changed from REV. A to REV. B.	
Remove 8-Lead SO PIN CONNECTION DIAGRAM	1
Changes to ABSOLUTE MAXIMUM RATINGS	2
Remove OP77B column from SPECIFICATIONS	2
Remove OP77B column from ELECTRICAL CHARACTERISTICS	3-5
Remove OP77G column from WAFER TEST LIMITS	6
Remove OP77G column from TYPICAL ELECTRICAL CHARACTERISTICS	6

