



# Low Noise Micropower 2.048 V, 2.5 V, and 4.096 V Precision Voltage References

## ADR290/ADR291/ADR292

### FEATURES

#### Supply Range

2.35 V to 15 V, ADR290

2.8 V to 15 V, ADR291

4.4 V to 15 V, ADR292

#### Supply Current 12 $\mu$ A Max

Low-Noise 6  $\mu$ V, 8  $\mu$ V, 12  $\mu$ V p-p (0.1 Hz–10 Hz)

#### High Output Current 5 mA

Temperature Range  $-40^{\circ}\text{C}$  to  $+125^{\circ}\text{C}$

Pin Compatible with REF02/REF19x

### APPLICATIONS

Portable Instrumentation

Precision Reference for 3 V and 5 V Systems

A/D and D/A Converter Reference

Solar-Powered Applications

Loop-Current-Powered Instruments

### PIN CONFIGURATIONS

#### 8-Lead Narrow Body SO (SO Suffix)

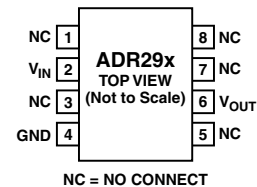

#### 8-Lead TSSOP (RU Suffix)

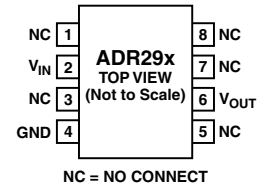

### GENERAL DESCRIPTION

The ADR290, ADR291 and ADR292 are low noise, micro-power precision voltage references that use an XFET<sup>®</sup> reference circuit. The new XFET architecture offers significant performance improvements over traditional bandgap and Buried Zener-based references. Improvements include: one quarter the voltage noise output of bandgap references operating at the same current, very low and ultralinear temperature drift, low thermal hysteresis and excellent long-term stability.

The ADR29x family are series voltage references providing stable and accurate output voltages from supplies as low as 2.35 V for the ADR290. Output voltage options are 2.048 V, 2.5 V, and 4.096 V for the ADR290, ADR291, and ADR292 respectively. Quiescent

current is only 12  $\mu$ A, making these devices ideal for battery-powered instrumentation. Three electrical grades are available offering initial output accuracies of  $\pm 2$  mV,  $\pm 3$  mV and  $\pm 6$  mV max for the ADR290 and ADR291, and  $\pm 3$  mV,  $\pm 4$  mV and  $\pm 6$  mV max for the ADR292. Temperature coefficients for the three grades are 8 ppm/ $^{\circ}\text{C}$ , 15 ppm/ $^{\circ}\text{C}$ , and 25 ppm/ $^{\circ}\text{C}$  max, respectively. Line regulation and load regulation are typically 30 ppm/V and 30 ppm/mA, maintaining the reference's overall high performance. For a device with 5.0 V output, refer to the ADR293 data sheet.

The ADR290, ADR291, and ADR292 references are specified over the extended industrial temperature range of  $-40^{\circ}\text{C}$  to  $+125^{\circ}\text{C}$ . Devices are available in the 8-lead SOIC and 8-lead TSSOP packages.

### ADR29x Product

Part Number	Output Voltage (V)	Initial Accuracy (%)	Temperature Coefficient (ppm/ $^{\circ}\text{C}$ ) Max
ADR290	2.048	0.10, 0.15, 0.29	8, 15, 25
ADR291	2.500	0.08, 0.12, 0.24	8, 15, 25
ADR292	4.096	0.07, 0.10, 0.15	8, 15, 25
ADR293	5.000	(See ADR293 Data Sheet)	

XFET is a registered trademark of Analog Devices, Inc.

### REV. B

Information furnished by Analog Devices is believed to be accurate and reliable. However, no responsibility is assumed by Analog Devices for its use, nor for any infringements of patents or other rights of third parties which may result from its use. No license is granted by implication or otherwise under any patent or patent rights of Analog Devices.

One Technology Way, P.O. Box 9106, Norwood, MA 02062-9106, U.S.A.  
Tel: 781/329-4700 World Wide Web Site: <http://www.analog.com>  
Fax: 781/326-8703 © Analog Devices, Inc., 2001

# ADR290/ADR291/ADR292

## ADR290—SPECIFICATIONS

### ELECTRICAL SPECIFICATIONS ( $V_S = 2.7\text{ V}$ , $T_A = +25^\circ\text{C}$ unless otherwise noted)

Parameter	Symbol	Conditions	Min	Typ	Max	Unit
E GRADE Output Voltage Initial Accuracy	$V_O$ $V_{OERR}$	$I_{OUT} = 0\text{ mA}$	2.046 -2 -0.10	2.048	2.050 +2 +0.10	V mV %
F GRADE Output Voltage Initial Accuracy	$V_O$ $V_{OERR}$	$I_{OUT} = 0\text{ mA}$	2.045 -3 -0.15	2.048	2.051 +3 +0.15	V mV %
G GRADE Output Voltage Initial Accuracy	$V_O$ $V_{OERR}$	$I_{OUT} = 0\text{ mA}$	2.042 -6 -0.29	2.048	2.054 +6 +0.29	V mV %
LINE REGULATION “E/F” Grades “G” Grade	$\Delta V_O/\Delta V_{IN}$	2.7 V to 15 V, $I_{OUT} = 0\text{ mA}$		30 40	100 125	ppm/V ppm/V
LOAD REGULATION “E/F” Grades “G” Grade	$\Delta V_O/\Delta I_{LOAD}$	$V_S = 5.0\text{ V}$ , 0 mA to 5 mA		30 40	100 125	ppm/mA ppm/mA
LONG-TERM STABILITY	$\Delta V_O$	After 1000 hrs of Operation @ $125^\circ\text{C}$		50		ppm
NOISE VOLTAGE	$e_N$	0.1 Hz to 10 Hz		6		$\mu\text{V p-p}$
WIDEBAND NOISE DENSITY	$e_N$	@ 1 kHz		420		$\text{nV}/\sqrt{\text{Hz}}$

### ELECTRICAL SPECIFICATIONS ( $V_S = 2.7\text{ V}$ , $T_A = -25^\circ\text{C} \leq T_A \leq +85^\circ\text{C}$ unless otherwise noted)

Parameter	Symbol	Conditions	Min	Typ	Max	Unit
TEMPERATURE COEFFICIENT “E” Grade “F” Grade “G” Grade	$TCV_O$	$I_{OUT} = 0\text{ mA}$		3 6 10	8 15 25	ppm/ $^\circ\text{C}$ ppm/ $^\circ\text{C}$ ppm/ $^\circ\text{C}$
LINE REGULATION “E/F” Grades “G” Grade	$\Delta V_O/\Delta V_{IN}$	2.7 V to 15 V, $I_{OUT} = 0\text{ mA}$		35 50	125 150	ppm/V ppm/V
LOAD REGULATION “E/F” Grades “G” Grade	$\Delta V_O/\Delta I_{LOAD}$	$V_S = 5.0\text{ V}$ , 0 mA to 5 mA		20 30	125 150	ppm/mA ppm/mA

### ELECTRICAL SPECIFICATIONS ( $V_S = 2.7\text{ V}$ , $T_A = -40^\circ\text{C} \leq T_A \leq +125^\circ\text{C}$ unless otherwise noted)

Parameter	Symbol	Conditions	Min	Typ	Max	Unit
TEMPERATURE COEFFICIENT “E” Grade “F” Grade “G” Grade	$TCV_O$	$I_{OUT} = 0\text{ mA}$		3 5 10	10 20 30	ppm/ $^\circ\text{C}$ ppm/ $^\circ\text{C}$ ppm/ $^\circ\text{C}$
LINE REGULATION “E/F” Grades “G” Grade	$\Delta V_O/\Delta V_{IN}$	2.7 V to 15 V, $I_{OUT} = 0\text{ mA}$		40 70	200 250	ppm/V ppm/V
LOAD REGULATION “E/F” Grades “G” Grade	$\Delta V_O/\Delta I_{LOAD}$	$V_S = 5.0\text{ V}$ , 0 mA to 5 mA		20 30	200 300	ppm/mA ppm/mA
SUPPLY CURRENT	$I_S$	$T_A = +25^\circ\text{C}$ $-40^\circ\text{C} \leq T_A \leq +125^\circ\text{C}$		8 12	12 15	$\mu\text{A}$ $\mu\text{A}$
THERMAL HYSTERESIS	$V_{O-HYS}$	SO-8, TSSOP-8		50		ppm

Specifications subject to change without notice.

# ADR291—SPECIFICATIONS

ADR290/ADR291/ADR292

## ELECTRICAL SPECIFICATIONS ( $V_S = 3.0\text{ V}$ , $T_A = +25^\circ\text{C}$ unless otherwise noted)

Parameter	Symbol	Conditions	Min	Typ	Max	Unit
E GRADE Output Voltage Initial Accuracy	$V_O$ $V_{OERR}$	$I_{OUT} = 0\text{ mA}$	2.498 -2 -0.08	2.500	2.502 +2 +0.08	V mV %
F GRADE Output Voltage Initial Accuracy	$V_O$ $V_{OERR}$	$I_{OUT} = 0\text{ mA}$	2.497 -3 -0.12	2.500	2.503 +3 +0.12	V mV %
G GRADE Output Voltage Initial Accuracy	$V_O$ $V_{OERR}$	$I_{OUT} = 0\text{ mA}$	2.494 -6 -0.24	2.500	2.506 +6 +0.24	V mV %
LINE REGULATION “E/F” Grades “G” Grade	$\Delta V_O/\Delta V_{IN}$	3.0 V to 15 V, $I_{OUT} = 0\text{ mA}$		30 40	100 125	ppm/V ppm/V
LOAD REGULATION “E/F” Grades “G” Grade	$\Delta V_O/\Delta I_{LOAD}$	$V_S = 5.0\text{ V}$ , 0 mA to 5 mA		30 40	100 125	ppm/mA ppm/mA
LONG-TERM STABILITY	$\Delta V_O$	After 1000 hrs of Operation @ $125^\circ\text{C}$		50		ppm
NOISE VOLTAGE	$e_N$	0.1 Hz to 10 Hz		8		$\mu\text{V p-p}$
WIDEBAND NOISE DENSITY	$e_N$	@ 1 kHz		480		$\text{nV}/\sqrt{\text{Hz}}$

## ELECTRICAL SPECIFICATIONS ( $V_S = 3.0\text{ V}$ , $T_A = -25^\circ\text{C} \leq T_A \leq +85^\circ\text{C}$ unless otherwise noted)

Parameter	Symbol	Conditions	Min	Typ	Max	Unit
TEMPERATURE COEFFICIENT “E” Grade “F” Grade “G” Grade	$TCV_O$	$I_{OUT} = 0\text{ mA}$		3 5 10	8 15 25	ppm/ $^\circ\text{C}$ ppm/ $^\circ\text{C}$ ppm/ $^\circ\text{C}$
LINE REGULATION “E/F” Grades “G” Grade	$\Delta V_O/\Delta V_{IN}$	3.0 V to 15 V, $I_{OUT} = 0\text{ mA}$		35 50	125 150	ppm/V ppm/V
LOAD REGULATION “E/F” Grades “G” Grade	$\Delta V_O/\Delta I_{LOAD}$	$V_S = 5.0\text{ V}$ , 0 mA to 5 mA		20 30	125 150	ppm/mA ppm/mA

## ELECTRICAL SPECIFICATIONS ( $V_S = 3.0\text{ V}$ , $T_A = -40^\circ\text{C} \leq T_A \leq +125^\circ\text{C}$ unless otherwise noted)

Parameter	Symbol	Conditions	Min	Typ	Max	Unit
TEMPERATURE COEFFICIENT “E” Grade “F” Grade “G” Grade	$TCV_O$	$I_{OUT} = 0\text{ mA}$		3 5 10	10 20 30	ppm/ $^\circ\text{C}$ ppm/ $^\circ\text{C}$ ppm/ $^\circ\text{C}$
LINE REGULATION “E/F” Grades “G” Grade	$\Delta V_O/\Delta V_{IN}$	3.0 V to 15 V, $I_{OUT} = 0\text{ mA}$		40 70	200 250	ppm/V ppm/V
LOAD REGULATION “E/F” Grades “G” Grade	$\Delta V_O/\Delta I_{LOAD}$	$V_S = 5.0\text{ V}$ , 0 mA to 5 mA		20 30	200 300	ppm/mA ppm/mA
SUPPLY CURRENT	$I_S$	$T_A = +25^\circ\text{C}$ $-40^\circ\text{C} \leq T_A \leq +125^\circ\text{C}$		9 12	12 15	$\mu\text{A}$ $\mu\text{A}$
THERMAL HYSTERESIS	$V_{O-HYS}$	SO-8, TSSOP-8		50		ppm

Specifications subject to change without notice.

# ADR290/ADR291/ADR292 ADR292—SPECIFICATIONS

## ELECTRICAL SPECIFICATIONS ( $V_S = 5\text{ V}$ , $T_A = +25^\circ\text{C}$ unless otherwise noted)

Parameter	Symbol	Conditions	Min	Typ	Max	Unit
E GRADE Output Voltage Initial Accuracy	$V_O$ $V_{OERR}$	$I_{OUT} = 0\text{ mA}$	4.093 -3 -0.07	4.096	4.099 +3 +0.07	V mV %
F GRADE Output Voltage Initial Accuracy	$V_O$ $V_{OERR}$	$I_{OUT} = 0\text{ mA}$	4.092 -4 -0.10	4.096	4.1 +4 +0.10	V mV %
G GRADE Output Voltage Initial Accuracy	$V_O$ $V_{OERR}$	$I_{OUT} = 0\text{ mA}$	4.090 -6 -0.15	4.096	4.102 +6 +0.15	V mV %
LINE REGULATION “E/F” Grades “G” Grade	$\Delta V_O/\Delta V_{IN}$	4.5 V to 15 V, $I_{OUT} = 0\text{ mA}$		30 40	100 125	ppm/V ppm/V
LOAD REGULATION “E/F” Grades “G” Grade	$\Delta V_O/\Delta I_{LOAD}$	$V_S = 5.0\text{ V}$ , 0 mA to 5 mA		30 40	100 125	ppm/mA ppm/mA
LONG-TERM STABILITY	$\Delta V_O$	After 1000 hrs of Operation @ $125^\circ\text{C}$		50		ppm
NOISE VOLTAGE	$\epsilon_N$	0.1 Hz to 10 Hz		12		$\mu\text{V p-p}$
WIDEBAND NOISE DENSITY	$\epsilon_N$	@ 1 kHz		640		$\text{nV}/\sqrt{\text{Hz}}$

## ELECTRICAL SPECIFICATIONS ( $V_S = 5\text{ V}$ , $T_A = -25^\circ\text{C} \leq T_A \leq +85^\circ\text{C}$ unless otherwise noted)

Parameter	Symbol	Conditions	Min	Typ	Max	Unit
TEMPERATURE COEFFICIENT “E” Grade “F” Grade “G” Grade	$TCV_O$	$I_{OUT} = 0\text{ mA}$		3 5 10	8 15 25	ppm/ $^\circ\text{C}$ ppm/ $^\circ\text{C}$ ppm/ $^\circ\text{C}$
LINE REGULATION “E/F” Grades “G” Grade	$\Delta V_O/\Delta V_{IN}$	4.5 V to 15 V, $I_{OUT} = 0\text{ mA}$		35 50	125 150	ppm/V ppm/V
LOAD REGULATION “E/F” Grades “G” Grade	$\Delta V_O/\Delta I_{LOAD}$	$V_S = 5.0\text{ V}$ , 0 mA to 5 mA		20 30	125 150	ppm/mA ppm/mA

## ELECTRICAL SPECIFICATIONS ( $V_S = 5\text{ V}$ , $T_A = -40^\circ\text{C} \leq T_A \leq +125^\circ\text{C}$ unless otherwise noted)

Parameter	Symbol	Conditions	Min	Typ	Max	Unit
TEMPERATURE COEFFICIENT “E” Grade “F” Grade “G” Grade	$TCV_O$	$I_{OUT} = 0\text{ mA}$		3 5 10	10 20 30	ppm/ $^\circ\text{C}$ ppm/ $^\circ\text{C}$ ppm/ $^\circ\text{C}$
LINE REGULATION “E/F” Grades “G” Grade	$\Delta V_O/\Delta V_{IN}$	4.5 V to 15 V, $I_{OUT} = 0\text{ mA}$		40 70	200 250	ppm/V ppm/V
LOAD REGULATION “E/F” Grades “G” Grade	$\Delta V_O/\Delta I_{LOAD}$	$V_S = 5.0\text{ V}$ , 0 mA to 5 mA		20 30	200 300	ppm/mA ppm/mA
SUPPLY CURRENT	$I_S$	$T_A = +25^\circ\text{C}$ $-40^\circ\text{C} \leq T_A \leq +125^\circ\text{C}$		10 12	15 18	$\mu\text{A}$ $\mu\text{A}$
THERMAL HYSTERESIS	$V_{O-HYS}$	SO-8, TSSOP-8		50		ppm

Specifications subject to change without notice.

# ADR290/ADR291/ADR292

## ABSOLUTE MAXIMUM RATINGS

Supply Voltage	18 V
Output Short-Circuit Duration to GND	Indefinite
Storage Temperature Range	
SO, RU Package	−65°C to +150°C
Operating Temperature Range	
ADR290/ADR291/ADR292	−40°C to +125°C
Junction Temperature Range	
SO, RU Package	−65°C to +125°C
Lead Temperature (Soldering, 60 sec)	300°C

Package Type	$\theta_{JA}^*$	$\theta_{JC}$	Unit
8-Lead SOIC (SO)	158	43	°C/W
8-Lead TSSOP (RU)	240	43	°C/W

\* $\theta_{JA}$  is specified for worst-case conditions, i.e.,  $\theta_{JA}$  is specified for device in socket testing. In practice,  $\theta_{JA}$  is specified for a device soldered in the circuit board.

## NOTES

- Stresses above those listed under Absolute Maximum Ratings may cause permanent damage to the device. This is a stress rating only; functional operation at or above this specification is not implied. Exposure to the above maximum rating conditions for extended periods may affect device reliability.
- Remove power before inserting or removing units from their sockets.

## CAUTION

ESD (electrostatic discharge) sensitive device. Electrostatic charges as high as 4000 V readily accumulate on the human body and test equipment and can discharge without detection. Although the ADR290/ADR291/ADR292 features proprietary ESD protection circuitry, permanent damage may occur on devices subjected to high-energy electrostatic discharges. Therefore, proper ESD precautions are recommended to avoid performance degradation or loss of functionality.



## ORDERING GUIDE

Model	Output Voltage	Initial Accuracy (%)	Temperature Coefficient Max (ppm/°C)	Package Description	Package Option	Number of Parts per Package
<b>ADR290</b>						
ER, ER-REEL7, ER-REEL	2.048	0.10	8	SOIC	SO-8	98, 1000, 2500
FR, FR-REEL7, FR-REEL	2.048	0.15	15	SOIC	SO-8	98, 1000, 2500
GR, GR-REEL7, GR-REEL	2.048	0.29	25	SOIC	SO-8	98, 1000, 2500
GRU-REEL7, GRU-REEL	2.048	0.29	25	TSSOP	RU-8	1000, 2500
<b>ADR291</b>						
ER, ER-REEL7, ER-REEL	2.50	0.08	8	SOIC	SO-8	98, 1000, 2500
FR, FR-REEL7, FR-REEL	2.50	0.12	15	SOIC	SO-8	98, 1000, 2500
GR, GR-REEL7, GR-REEL	2.50	0.24	25	SOIC	SO-8	98, 1000, 2500
GRU-REEL7, GRU-REEL	2.50	0.24	25	TSSOP	RU-8	1000, 2500
<b>ADR292</b>						
ER, ER-REEL7, ER-REEL	4.096	0.07	8	SOIC	SO-8	98, 1000, 2500
FR, FR-REEL7, FR-REEL	4.096	0.10	15	SOIC	SO-8	98, 1000, 2500
GR, GR-REEL7, GR-REEL	4.096	0.15	25	SOIC	SO-8	98, 1000, 2500
GRU-REEL7, GRU-REEL	4.096	0.15	25	TSSOP	RU-8	1000, 2500

See ADR293 data sheet for ordering guide.

## OTHER XFET PRODUCTS

Part Number	Nominal Output Voltage (V)	Package Type
ADR420	2.048	8-Lead_μSOIC/SOIC
ADR421	2.50	8-Lead_μSOIC/SOIC

# ADR290/ADR291/ADR292

## PARAMETER DEFINITION

### Line Regulation

The change in output voltage due to a specified change in input voltage. It includes the effects of self-heating. Line regulation is expressed in either percent-per-volt, parts-per-million-per-volt, or microvolts-per-volt change in input voltage.

### Load Regulation

The change in output voltage due to a specified change in load current. It includes the effects of self-heating. Load regulation is expressed in either microvolts-per-milliampere, parts-per-million-per-milliampere, or ohms of dc output resistance.

### Long-Term Stability

Typical shift of output voltage at 25°C on a sample of parts subjected to high-temperature operating life test of 1000 hours at 125°C.

$$\Delta V_O = V_O(t_0) - V_O(t_1)$$
$$\Delta V_O [ppm] = \frac{V_O(t_0) - V_O(t_1)}{V_O(t_0)} \times 10^6$$

Where

$$V_O(t_0) = V_O \text{ at } 25^\circ\text{C at time } 0$$

$$V_O(t_1) = V_O \text{ at } 25^\circ\text{C after 1000 hours operation at } 125^\circ\text{C}$$

### Temperature Coefficient

The change of output voltage over the operating temperature change and normalized by the output voltage at 25°C, expressed in ppm/°C. The equation follows:

$$TCV_O [ppm/^\circ\text{C}] = \frac{V_O(T_2) - V_O(T_1)}{V_O(25^\circ\text{C}) \times (T_2 - T_1)} \times 10^6$$

Where

$$V_O(25^\circ\text{C}) = V_O \text{ at } 25^\circ\text{C}$$

$$V_O(T_1) = V_O \text{ at Temperature } 1$$

$$V_O(T_2) = V_O \text{ at Temperature } 2$$

NC = No Connect

(There are in fact internal connections at NC pins which are reserved for manufacturing purposes. Users should not connect anything at NC pins.)

### Thermal Hysteresis

Thermal hysteresis is defined as the change of output voltage after the device is cycled through temperature from +25°C to -40°C to +85°C and back to +25°C. This is a typical value from a sample of parts put through such a cycle.

$$V_{O-HYS} = V_O(25^\circ\text{C}) - V_{O\_TC}$$
$$V_{O-HYS} [ppm] = \frac{V_O(25^\circ\text{C}) - V_{O\_TC}}{V_O(25^\circ\text{C})} \times 10^6$$

Where

$$V_O(25^\circ\text{C}) = V_O \text{ at } 25^\circ\text{C}$$

$$V_{O\_TC} = V_O \text{ at } 25^\circ\text{C after temperature cycle at } +25^\circ\text{C to } -40^\circ\text{C to } +85^\circ\text{C and back to } +25^\circ\text{C}$$

# Typical Performance Characteristic—ADR290/ADR291/ADR292

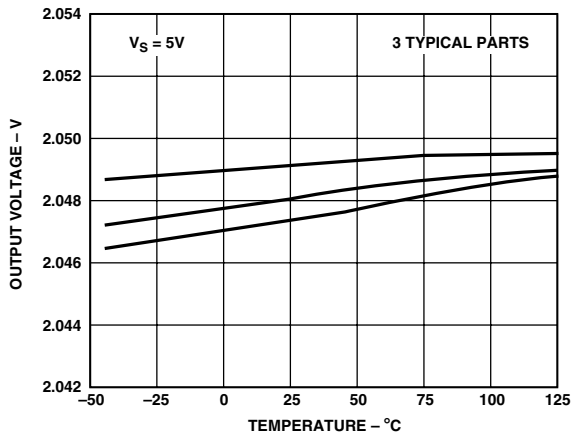

TPC 1. ADR290  $V_{OUT}$  vs. Temperature

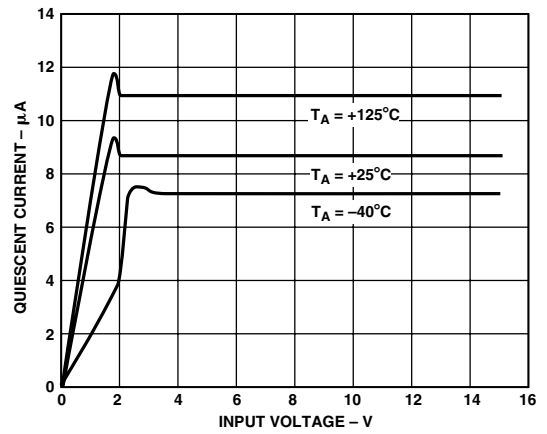

TPC 4. ADR290 Quiescent Current vs. Input Voltage

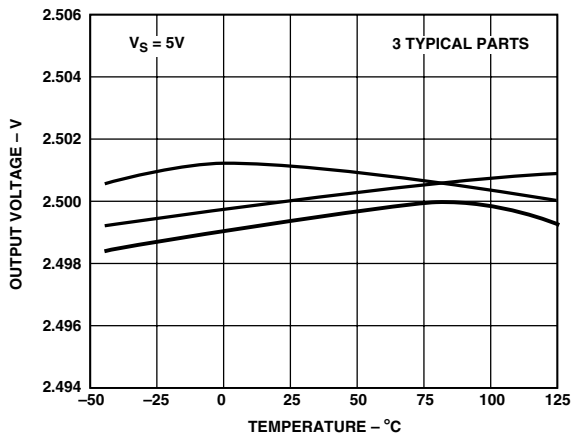

TPC 2. ADR291  $V_{OUT}$  vs. Temperature

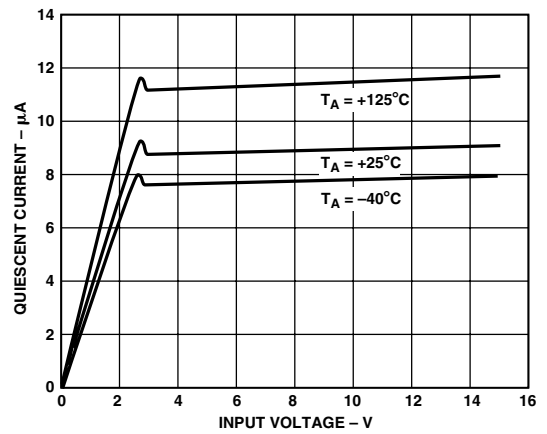

TPC 5. ADR291 Quiescent Current vs. Input Voltage

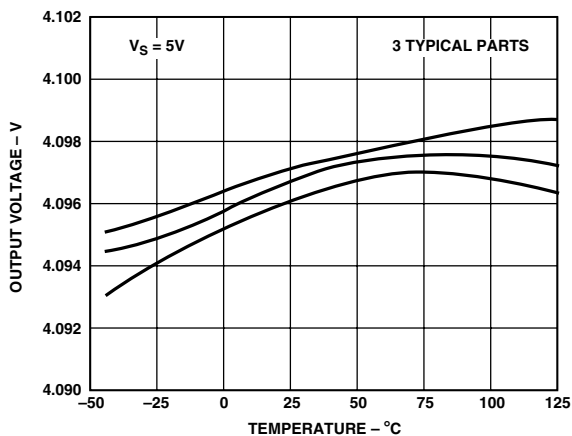

TPC 3. ADR292  $V_{OUT}$  vs. Temperature

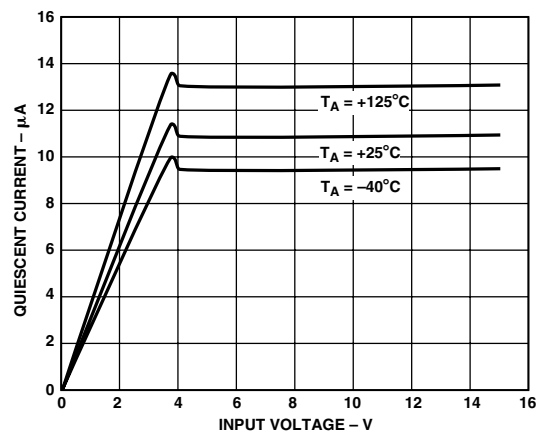

TPC 6. ADR292 Quiescent Current vs. Input Voltage

# ADR290/ADR291/ADR292

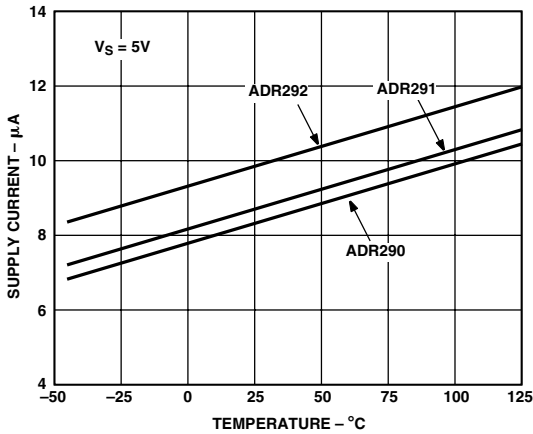

TPC 7. ADR290/ADR291/ADR292 Supply Current vs. Temperature

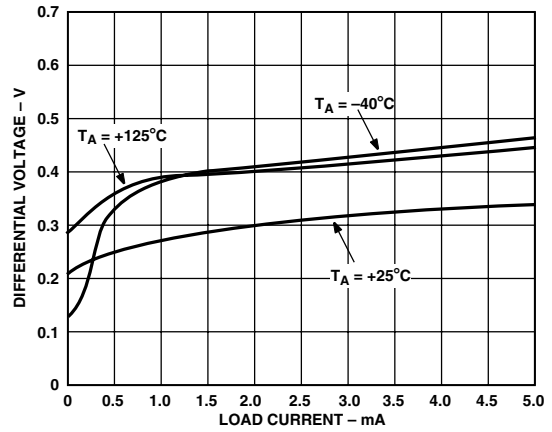

TPC 10. ADR290 Minimum Input-Output Voltage Differential vs. Load Current

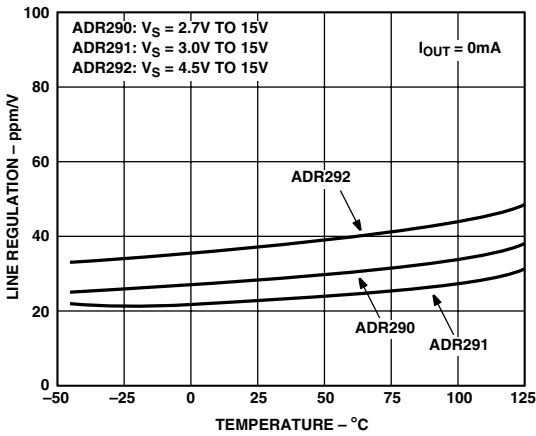

TPC 8. ADR290/ADR291/ADR292 Line Regulation vs. Temperature

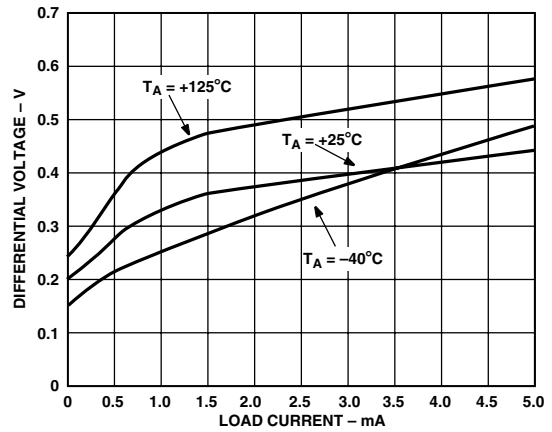

TPC 11. ADR291 Minimum Input-Output Voltage Differential vs. Load Current

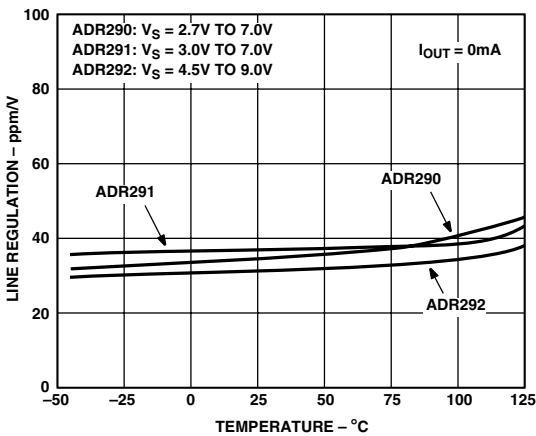

TPC 9. ADR290/ADR291/ADR292 Line Regulation vs. Temperature

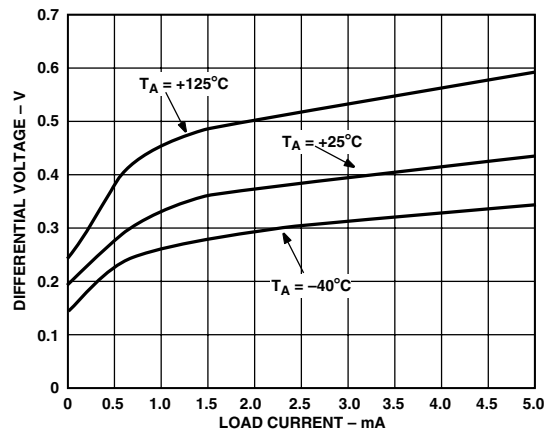

TPC 12. ADR292 Minimum Input-Output Voltage Differential vs. Load Current



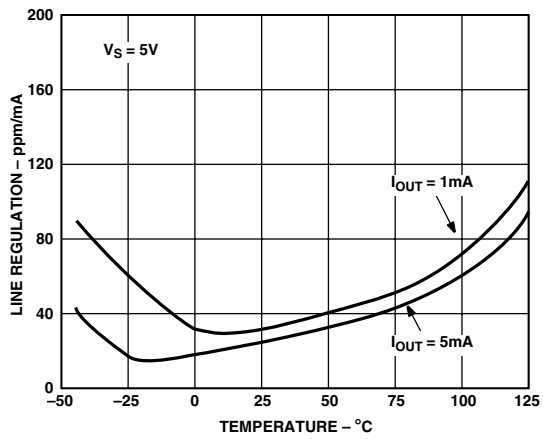

TPC 13. ADR290 Line Regulation vs. Temperature

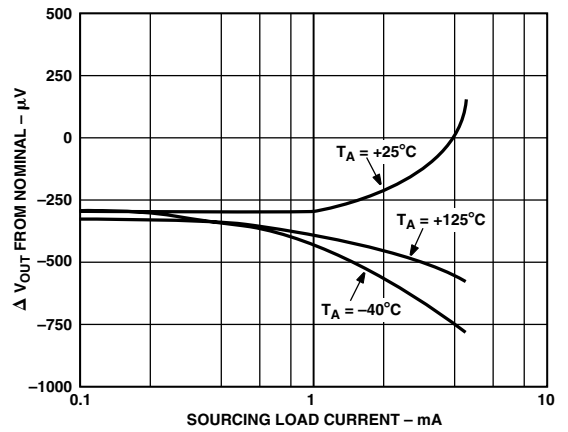

TPC 16. ADR290  $\Delta V_{OUT}$  from Nominal vs. Load Current

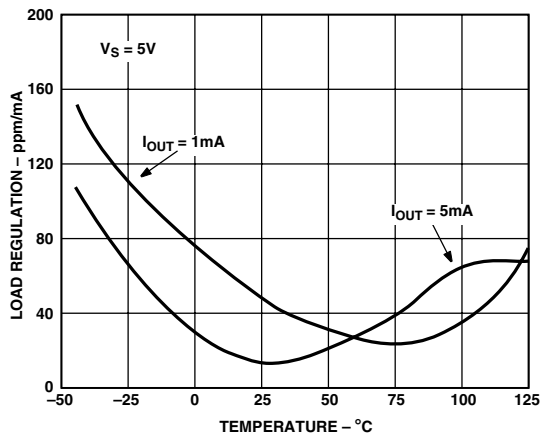

TPC 14. ADR291 Load Regulation vs. Temperature

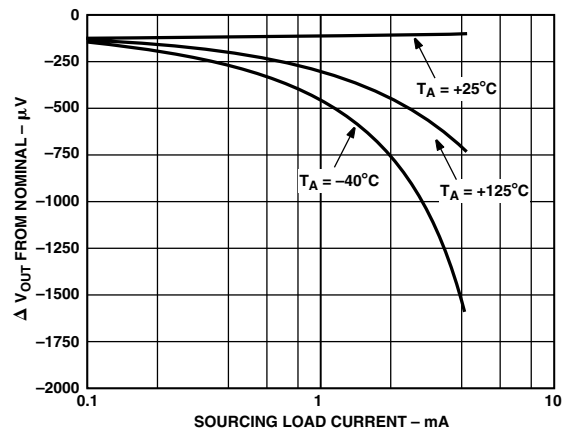

TPC 17. ADR291  $\Delta V_{OUT}$  from Nominal vs. Load Current

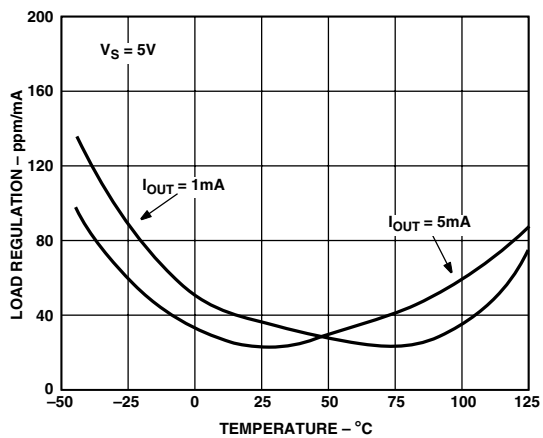

TPC 15. ADR292 Load Regulation vs. Temperature

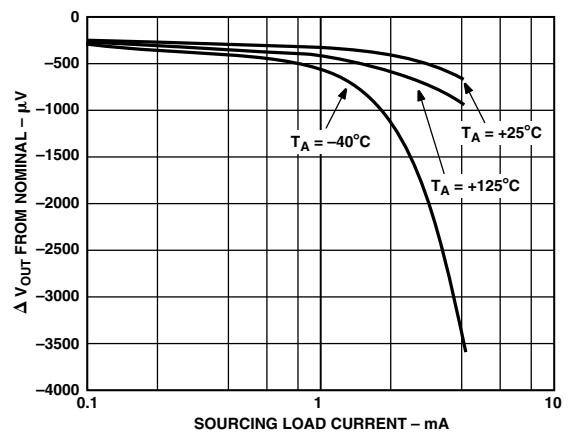

TPC 18. ADR292  $\Delta V_{OUT}$  from Nominal vs. Load Current

# ADR290/ADR291/ADR292

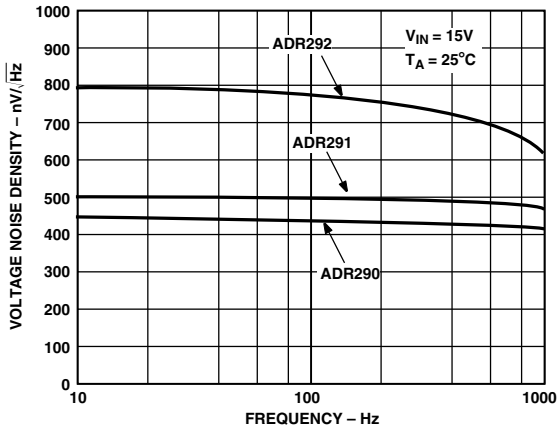

TPC 19. Voltage Noise Density vs. Frequency

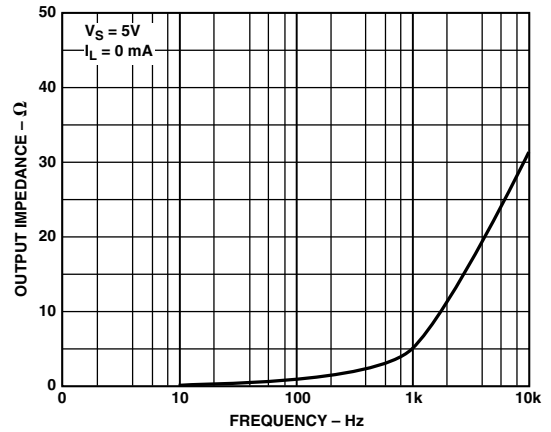

TPC 22. ADR290 Output Impedance vs. Frequency

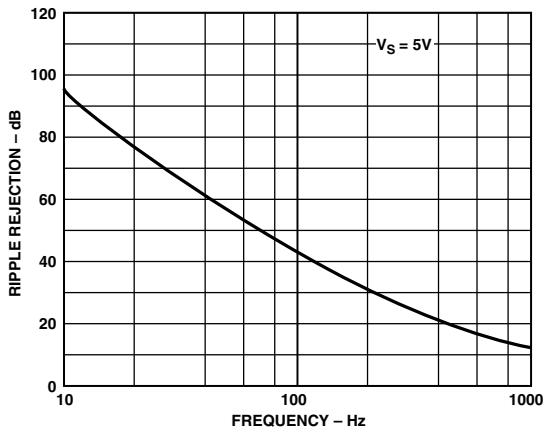

TPC 20. ADR290/ADR291/ADR292 Ripple Rejection vs. Frequency

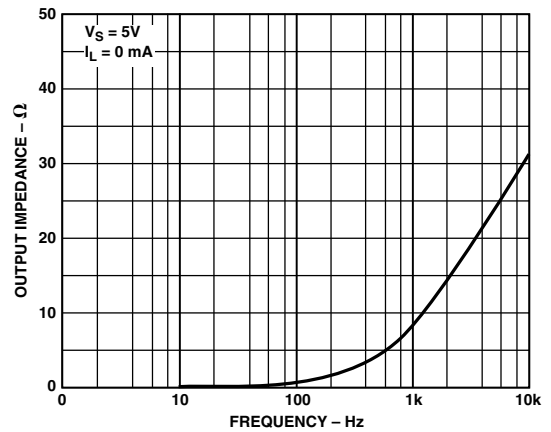

TPC 23. ADR291 Output Impedance vs. Frequency

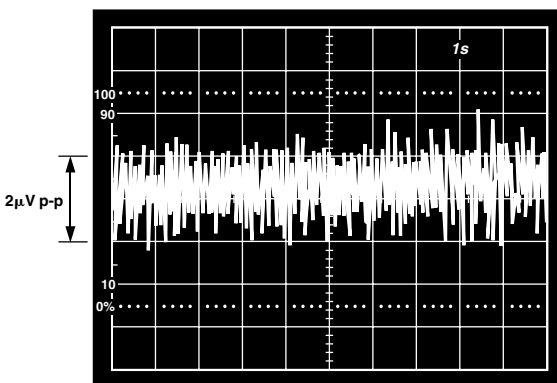

TPC 21. ADR290 0.1 Hz to 10 Hz Noise

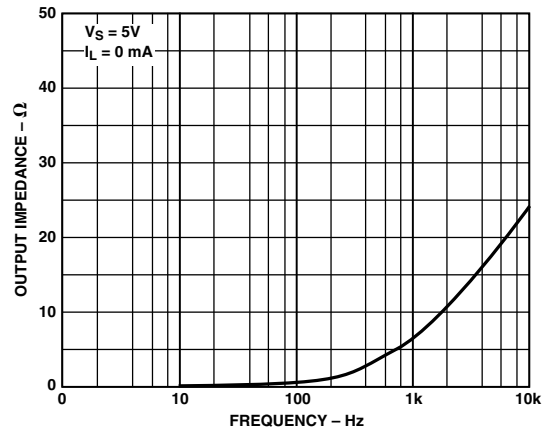

TPC 24. ADR292 Output Impedance vs. Frequency

ADR290/ADR291/ADR292

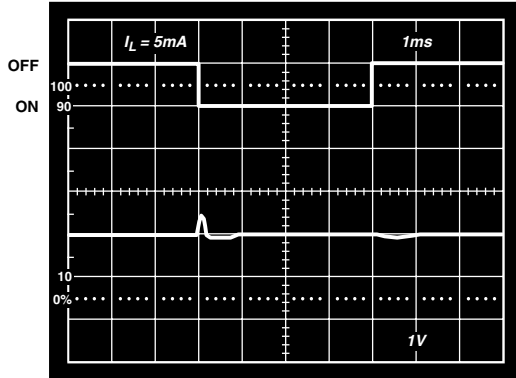

TPC 25. ADR291 Load Transient

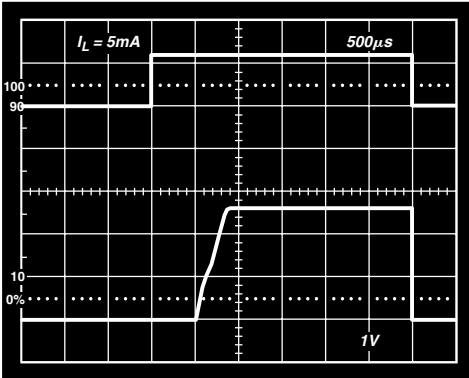

TPC 28. ADR291 Turn-On Time

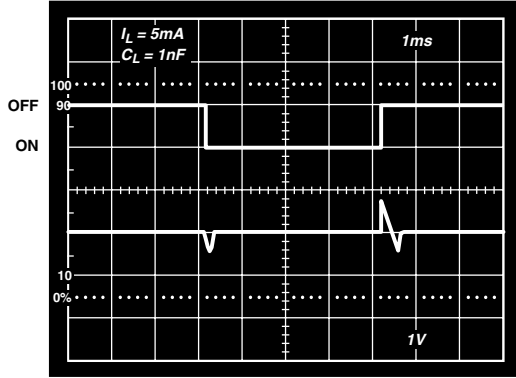

TPC 26. ADR291 Load Transient

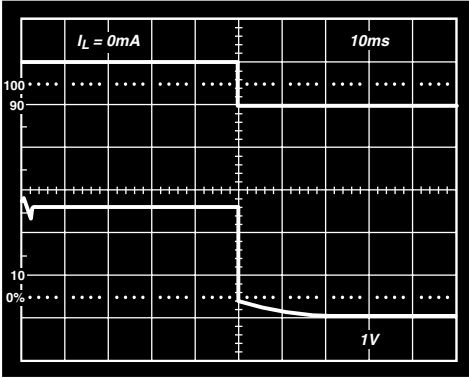

TPC 29. ADR291 Turn-Off Time

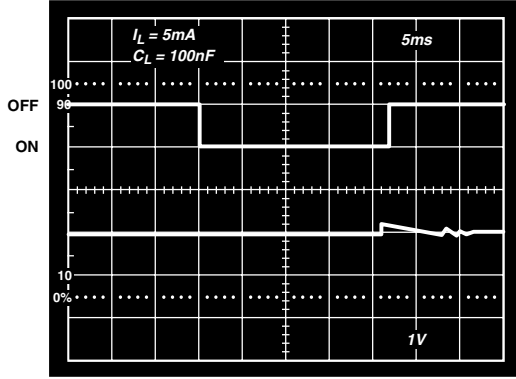

TPC 27. ADR291 Load Transient

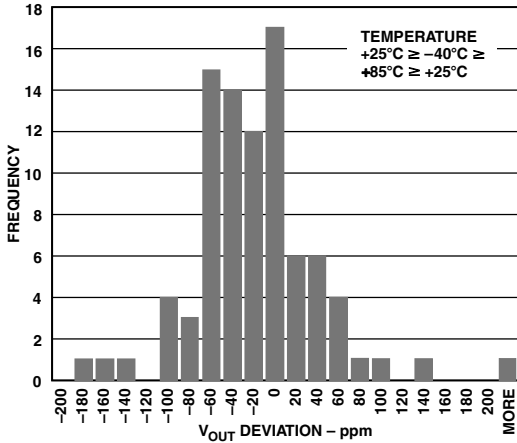

TPC 30. Typical Hysteresis for the ADR291 Product

# ADR290/ADR291/ADR292

## THEORY OF OPERATION

The ADR29x series of references uses a new reference generation technique known as XFET (eXtra implanted junction FET). This technique yields a reference with low noise, low supply current and very low thermal hysteresis.

The core of the XFET reference consists of two junction field-effect transistors, one of which has an extra channel implant to raise its pinch-off voltage. By running the two JFETs at the same drain current, the difference in pinch-off voltage can be amplified and used to form a highly stable voltage reference.

The intrinsic reference voltage is around 0.5 V with a negative temperature coefficient of about -120 ppm/K. This slope is essentially locked to the dielectric constant of silicon and can be closely compensated by adding a correction term generated in the same fashion as the proportional-to-temperature (PTAT) term used to compensate bandgap references. The big advantage over a bandgap reference is that the intrinsic temperature coefficient is some thirty times lower (therefore less correction is needed) and this results in much lower noise since most of the noise of a bandgap reference comes from the temperature compensation circuitry.

The simplified schematic below shows the basic topology of the ADR29x series. The temperature correction term is provided by a current source with value designed to be proportional to absolute temperature. The general equation is:

$$V_{OUT} = \Delta V_P \left( \frac{R1 + R2 + R3}{R1} \right) + (I_{PTAT})(R3)$$

where  $\Delta V_P$  is the difference in pinch-off voltage between the two FETs, and  $I_{PTAT}$  is the positive temperature coefficient correction current. The various versions of the ADR29x family are created by on-chip adjustment of R1 and R3 to achieve 2.048 V, 2.500 V or 4.096 V at the reference output.

The process used for the XFET reference also features vertical NPN and PNP transistors, the latter of which are used as output devices to provide a very low drop-out voltage.

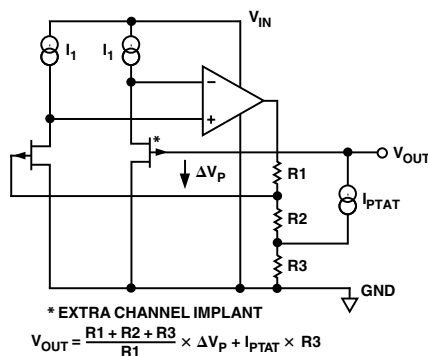

Figure 1. ADR290/ADR291/ADR292 Simplified Schematic

## Device Power Dissipation Considerations

The ADR29x family of references is guaranteed to deliver load currents to 5 mA with an input voltage that ranges from 2.7 V to 15 V (minimum supply voltage depends on output voltage option). When these devices are used in applications with large input voltages, care should be exercised to avoid exceeding the published specifications for maximum power dissipation or junction temperature that could result in premature device failure. The following formula should be used to calculate a device's maximum junction temperature or dissipation:

$$P_D = \frac{T_J - T_A}{\theta_{JA}}$$

In this equation,  $T_J$  and  $T_A$  are the junction and ambient temperatures, respectively,  $P_D$  is the device power dissipation, and  $\theta_{JA}$  is the device package thermal resistance.

## Basic Voltage Reference Connections

References, in general, require a bypass capacitor connected from the  $V_{OUT}$  pin to the GND pin. The circuit in Figure 2 illustrates the basic configuration for the ADR29x family of references. Note that the decoupling capacitors are not required for circuit stability.

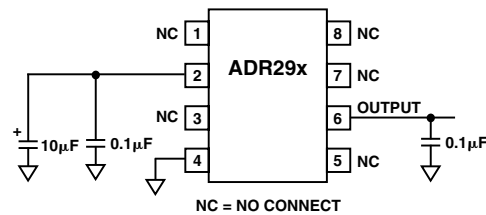

Figure 2. Basic Voltage Reference Configuration

## Noise Performance

The noise generated by the ADR29x family of references is typically less than 12  $\mu$ V p-p over the 0.1 Hz to 10 Hz band. TPC 21 shows the 0.1 Hz to 10 Hz noise of the ADR290 which is only 6  $\mu$ V p-p. The noise measurement is made with a bandpass filter made of a 2-pole high-pass filter with a corner frequency at 0.1 Hz and a 2-pole low-pass filter with a corner frequency at 10 Hz.

## Turn-On Time

Upon application of power (cold start), the time required for the output voltage to reach its final value within a specified error band is defined as the turn-on settling time. Two components normally associated with this are the time for the active circuits to settle, and the time for the thermal gradients on the chip to stabilize. TPC 28 shows the turn-on settling time for the ADR291.

## APPLICATIONS SECTION

### A Negative Precision Reference without Precision Resistors

In many current-output CMOS DAC applications, where the output signal voltage must be of the same polarity as the reference voltage, it is often required to reconfigure a current-switching DAC into a voltage-switching DAC through the use of a 1.25 V reference, an op amp and a pair of resistors. Using a current-switching DAC directly requires the need for an additional operational amplifier at the output to reinvert the signal. A negative voltage reference is then desirable from the point that an additional operational amplifier is not required for either reinversion (current-switching mode) or amplification (voltage-switching mode) of the DAC output voltage. In general, any positive voltage reference can be converted into a negative voltage reference through the use of an operational amplifier and a pair of matched resistors in an inverting configuration. The disadvantage to that approach is that the largest single source of error in the circuit is the relative matching of the resistors used.

The circuit illustrated in Figure 3 avoids the need for tightly matched resistors with the use of an active integrator circuit. In this circuit, the output of the voltage reference provides the input drive for the integrator. The integrator, to maintain circuit equilibrium adjusts its output to establish the proper relationship between the reference's  $V_{OUT}$  and GND. Thus, any negative output voltage desired can be chosen by simply substituting for the appropriate reference IC. One caveat with this approach should be mentioned: although rail-to-rail output amplifiers work best in the application, these operational amplifiers require a finite amount (mV) of headroom when required to provide any load current. The choice for the circuit's negative supply should take this issue into account.

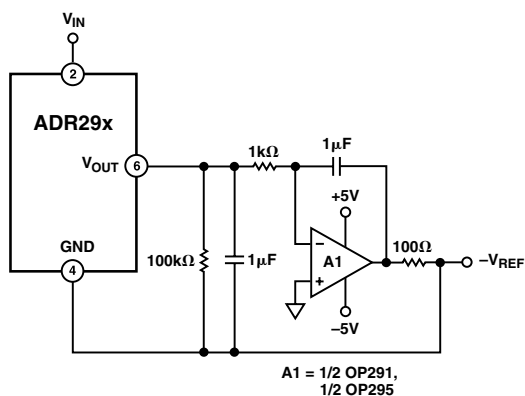

Figure 3. A Negative Precision Voltage Reference Uses No Precision Resistors

### A Precision Current Source

Many times in low power applications, the need arises for a precision current source that can operate on low supply voltages. As shown in Figure 4, any one of the devices in the ADR29x family of references can be configured as a precision current source. The circuit configuration illustrated is a floating current source with a grounded load. The reference's output voltage is bootstrapped across  $R_{SET}$ , which sets the output current into the load. With this configuration, circuit precision is maintained for load currents in the range from the reference's supply current, typically 12  $\mu$ A to approximately 5 mA.

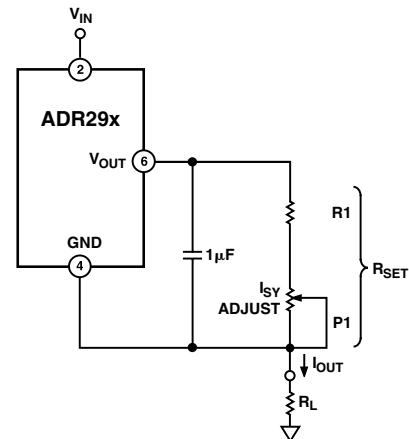

Figure 4. A Precision Current Source

### High Voltage Floating Current Source

The circuit of Figure 5 can be used to generate a floating current source with minimal self heating. This particular configuration can operate on high supply voltages determined by the breakdown voltage of the N-channel JFET.

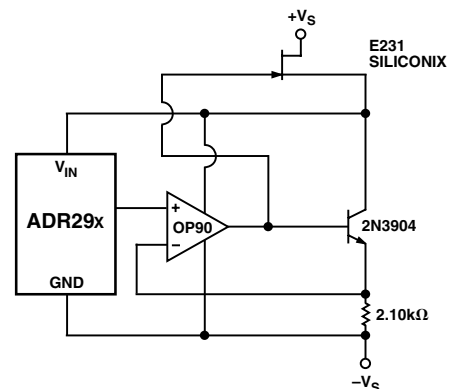

Figure 5. High Voltage Floating Current Source

### Kelvin Connections

In many portable instrumentation applications, where PC board cost and area go hand-in-hand, circuit interconnects are very often of dimensionally minimum width. These narrow lines can cause large voltage drops if the voltage reference is required to provide load currents to various functions. In fact, a circuit's interconnects can exhibit a typical line resistance of 0.45  $m\Omega$ /square (1 oz. Cu, for example). Force and sense connections also referred to as Kelvin connections, offer a convenient method of eliminating the effects of voltage drops in circuit wires. Load currents flowing through wiring resistance produce an error ( $V_{ERROR} = R \times I_L$ ) at the load. However, the Kelvin connection of Figure 6, overcomes the problem by including the wiring resistance within the forcing loop of the op amp. Since the op amp senses the load voltage, op amp loop control forces the output to compensate for the wiring error and to produce the correct voltage at the load.

# ADR290/ADR291/ADR292

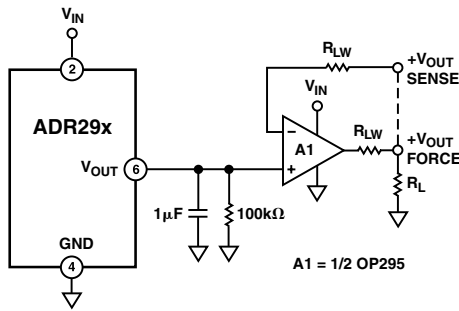

Figure 6. Advantage of Kelvin Connection

## Low Power, Low Voltage Reference For Data Converters

The ADR29x family has a number of features that makes it ideally suited for use with A/D and D/A converters. The low supply voltage required makes it possible to use the ADR290 and ADR291 with today's converters that run on 3 V supplies without having to add a higher supply voltage for the reference. The low quiescent current (12 μA max) and low noise, tight temperature coefficient, combined with the high accuracy of the ADR29x makes it ideal for low power applications such as hand-held, battery operated equipment.

One such ADC for which the ADR291 is well suited is the AD7701. Figure 7 shows the ADR291 used as the reference for this converter. The AD7701 is a 16-bit A/D converter with on-chip digital filtering intended for the measurement of wide dynamic range, low frequency signals such as those representing chemical, physical or biological processes. It contains a charge balancing (sigma-delta) ADC, calibration microcontroller with on-chip static RAM, a clock oscillator and a serial communications port.

This entire circuit runs on ±5 V supplies. The power dissipation of the AD7701 is typically 25 mW and, when combined with the power dissipation of the ADR291 (60 μW), the entire circuit still consumes about 25 mW.

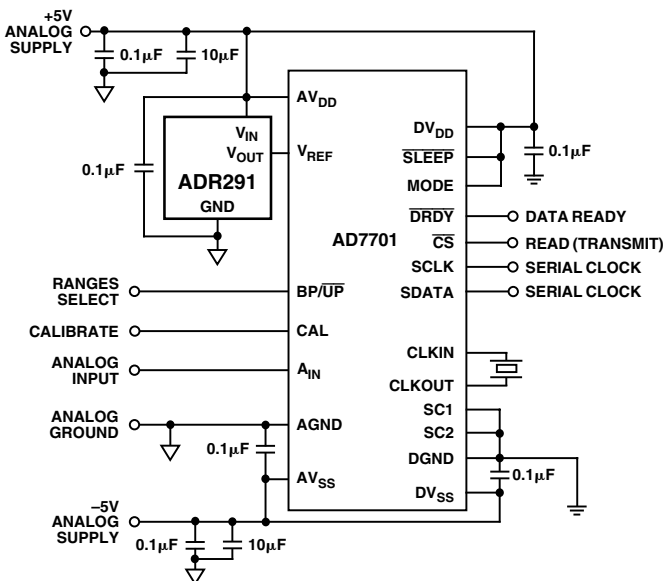

Figure 7. Low Power, Low Voltage Supply Reference for the AD7701

## Voltage Regulator For Portable Equipment

The ADR29x family of references is ideal for providing a stable, low cost and low power reference voltage in portable equipment power supplies. Figure 8 shows how the ADR290/ADR291/ADR292 can be used in a voltage regulator that not only has low output noise (as compared to switch mode design) and low power, but also a very fast recovery after current surges. Some precautions should be taken in the selection of the output capacitors. Too high an ESR (Effective Series Resistance) could endanger the stability of the circuit. A solid tantalum capacitor, 16 V or higher, and an aluminum electrolytic capacitor, 10 V or higher, are recommended for C1 and C2, respectively. Also, the path from the ground side of C1 and C2 to the ground side of R1 should be kept as short as possible.

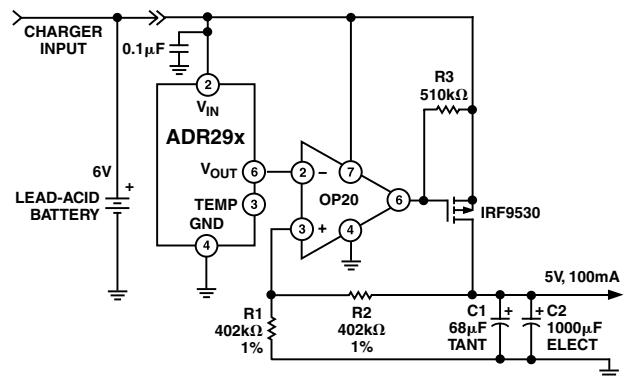

Figure 8. Voltage Regulator for Portable Equipment

# ADR290/ADR291/ADR292

## OUTLINE DIMENSIONS

Dimensions shown in inches and (mm).

### 8-Lead Narrow Body SO (SO Suffix)

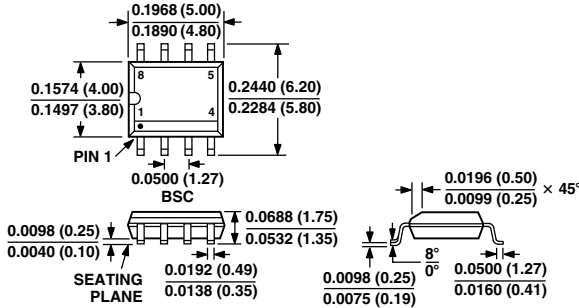

### 8-Lead TSSOP (RU Suffix)

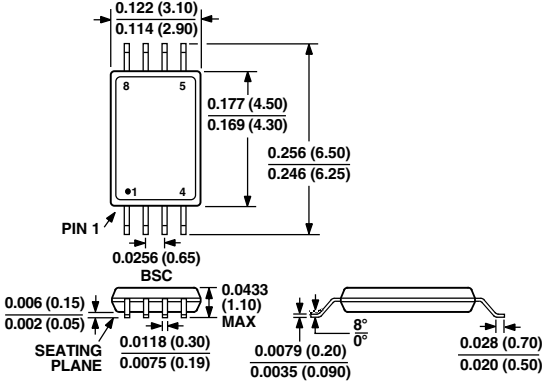

C00163-0-3/01 (B)

PRINTED IN U.S.A.