

ADM809/ADM810

FEATURES

- Superior Upgrade for MAX809/MAX810
- Specified Over Temperature
- Low Power Consumption (17 μ A)
- Precision Voltage Monitor: +3 V, +3.3 V, +5 V Options
- Reset Assertion Down to 1 V V_{CC}
- 140 ms min Power-On Reset
 - Logic Low $\overline{\text{RESET}}$ Output (ADM809)
 - Logic High RESET Output (ADM810)

APPLICATIONS

- Microprocessor Systems
- Computers
- Controllers
- Intelligent Instruments
- Automotive Systems

GENERAL DESCRIPTION

The ADM809/ADM810 supervisory circuits monitor the power supply voltage in microprocessor systems. They provide a reset output during power-up, power-down and brownout conditions. On power-up, an internal timer holds reset asserted for 240 ms. This holds the microprocessor in a reset state until conditions have stabilized. The RESET output remains operational with V_{CC} as low as 1 V. The ADM809 provides an active low reset signal ($\overline{\text{RESET}}$) while the ADM810 provides an active high signal (RESET) output.

Six reset threshold voltage options are available suitable for monitoring a variety of supply voltages. Refer to Table I.

The reset comparator features built-in glitch immunity, making it immune to fast transients on V_{CC} .

The ADM809/ADM810 consumes only 17 μ A, making it suitable for low power portable equipment. It is packaged in a 3-pin SOT-23 package.

FUNCTIONAL BLOCK DIAGRAM

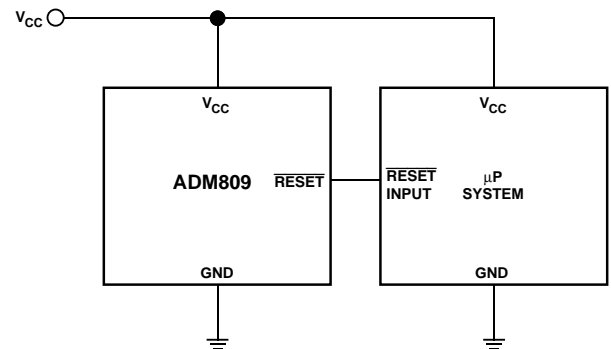
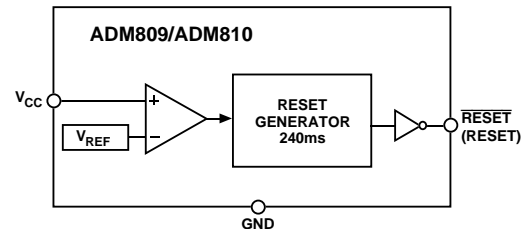

Figure 1. Typical Operating Circuit

REV. 0

Information furnished by Analog Devices is believed to be accurate and reliable. However, no responsibility is assumed by Analog Devices for its use, nor for any infringements of patents or other rights of third parties which may result from its use. No license is granted by implication or otherwise under any patent or patent rights of Analog Devices.

ADM809/ADM810—SPECIFICATIONS (V_{CC} = Full Operating Range, T_A = T_{MIN} to T_{MAX}, V_{CC} typ = 5 V for L/M/), 3.3 V for T/S, 3 V for R Models unless otherwise noted.)

Parameter	Min	Typ	Max	Units	Test Conditions/Comments
V _{CC} Operating Voltage Range	1.0		5.5	V	T _A = 0°C to +70°C
Supply Current	1.2		5.5	V	T _A = -40°C to +105°C
		24	60	μA	V _{CC} < 5.5 V, ADM8_L/M, T _A = -40°C to +85°C
		17	50	μA	V _{CC} < 3.6 V, ADM8_R/S/T, T _A = -40°C to +85°C
			100	μA	V _{CC} < 5.5 V, ADM8_L/M, T _A = +85°C to +105°C
			100	μA	V _{CC} < 3.6 V, ADM8_R/S/T, T _A = +85°C to +105°C
RESET THRESHOLD					
Reset Voltage Threshold					
ADM8_L	4.56	4.63	4.70	V	T _A = +25°C
ADM8_L	4.5		4.75	V	T _A = -40°C to +85°C
ADM8_L	4.40		4.86	V	T _A = +85°C to +105°C
ADM8_M	4.31	4.38	4.45	V	T _A = +25°C
ADM8_M	4.25		4.5	V	T _A = -40°C to +85°C
ADM8_M	4.16		4.56	V	T _A = +85°C to +105°C
ADM8_J	3.93	4.00	4.06	V	T _A = +25°C
ADM8_J	3.89		4.10	V	T _A = -40°C to +85°C
ADM8_J	3.80		4.20	V	T _A = +85°C to +105°C
ADM8_T	3.04	3.08	3.11	V	T _A = +25°C
ADM8_T	3.00		3.15	V	T _A = -40°C to +85°C
ADM8_T	2.92		3.23	V	T _A = +85°C to +105°C
ADM8_S	2.89	2.93	2.96	V	T _A = +25°C
ADM8_S	2.85		3.00	V	T _A = -40°C to +85°C
ADM8_S	2.78		3.08	V	T _A = +85°C to +105°C
ADM8_R	2.59	2.63	2.66	V	T _A = +25°C
ADM8_R	2.55		2.70	V	T _A = -40°C to +85°C
ADM8_R	2.50		2.76	V	T _A = +85°C to +105°C
Reset Threshold Temperature Coefficient		30		ppm/°C	
V _{CC} to Reset Delay		20		μs	V _{CC} = V _{TH} to (V _{TH} - 100 mV)
Reset Active Timeout Period	140	240	560	ms	T _A = -40°C to +85°C
	100		840	ms	T _A = +85°C to +105°C
$\overline{\text{RESET}}$ Output Voltage Low (ADM809)			0.3	V	V _{CC} = V _{TH} min, I _{SINK} = 1.2 mA, ADM809R/S/T
			0.4	V	V _{CC} = V _{TH} min, I _{SINK} = 3.2 mA, ADM809L/M
			0.3	V	V _{CC} > 1.0 V, I _{SINK} = 50 μA
$\overline{\text{RESET}}$ Output Voltage High (ADM809)	0.8 V _{CC}			V	V _{CC} > V _{TH} max, I _{SOURCE} = 500 μA, ADM809R/S/T
	V _{CC} -1.5			V	V _{CC} > V _{TH} max, I _{SOURCE} = 800 μA, ADM809L/M
RESET Output Voltage Low (ADM810)			0.3	V	V _{CC} = V _{TH} min, I _{SINK} = 1.2 mA, ADM810R/S/T
			0.4	V	V _{CC} = V _{TH} min, I _{SINK} = 3.2 mA, ADM810L/M
RESET Output Voltage High (ADM810)	0.8 V _{CC}			V	1.8 V < V _{CC} < V _{TH} min, I _{SOURCE} = 150 μA

ABSOLUTE MAXIMUM RATINGS*

(T_A = +25°C unless otherwise noted)

V _{CC}	-0.3 V to +6 V
RESET, $\overline{\text{RESET}}$	-0.3 V to V _{CC} + 0.5 V
Input Current	
V _{CC}	20 mA
Output Current	
RESET, $\overline{\text{RESET}}$	20 mA
Rate of Rise, V _{CC}	100 V/μs

Power Dissipation, RT-3 SOT-23 320 mW
Derate by 4 mW/°C above +70°C

θ _{JA} Thermal Impedance	333°C/W
Lead Temperature (Soldering, 10 sec)	+300°C
Vapor Phase (60 sec)	+215°C
Infrared (15 sec)	+220°C
Storage Temperature Range	-65°C to +150°C

*Stresses above those listed under Absolute Maximum Ratings may cause permanent damage to the device. This is a stress rating only; functional operation of the device at these or any other conditions above those listed in the operational sections of this specification is not implied. Exposure to absolute maximum ratings for extended periods of time may affect device reliability.

CAUTION

ESD (electrostatic discharge) sensitive device. Electrostatic charges as high as 4000 V readily accumulate on the human body and test equipment and can discharge without detection. Although the ADM809/ADM810 features proprietary ESD protection circuitry, permanent damage may occur on devices subjected to high energy electrostatic discharges. Therefore, proper ESD precautions are recommended to avoid performance degradation or loss of functionality.



ADM809/ADM810

PIN FUNCTION DESCRIPTION

Pin	Mnemonic	Function
1	GND	0 V. Ground reference for all signals.
2	$\overline{\text{RESET}}$ (ADM809)	Active Low Logic Output. $\overline{\text{RESET}}$ remains low while V_{CC} is below the reset threshold, and remains low for 240 ms (typ) after V_{CC} rises above the reset threshold
2	RESET (ADM810)	Active High Logic Output. RESET remains high while V_{CC} is below the reset threshold, and remains high for 240 ms (typ) after V_{CC} rises above the reset threshold.
3	V_{CC}	Supply voltage being monitored.

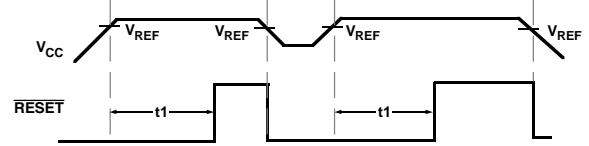

t_1 = RESET TIME = 240ms TYP.
 V_{REF} = RESET VOLTAGE THRESHOLD

Figure 2. Power Fail Reset Timing

Table I. Reset Threshold Options

Model	RESET Threshold
ADM809LART	4.63 V
ADM809MART	4.38 V
ADM809JART	4.00 V
ADM809TART	3.08 V
ADM809SART	2.93 V
ADM809RART	2.63 V
ADM810LART	4.63 V
ADM810MART	4.38 V
ADM810JART	4.00 V
ADM810TART	3.08 V
ADM810SART	2.93 V
ADM810RART	2.63 V

PIN CONFIGURATION

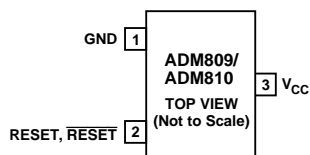

ORDERING GUIDE

Model*	Reset Threshold	Temperature Range	Brand Information	Quantity
ADM809LART-REEL	4.63 V	-40°C to +105°C	9LXX	10K
ADM809LART-REEL-7	4.63 V	-40°C to +105°C	9LXX	3K
ADM809MART-REEL	4.38 V	-40°C to +105°C	9MXX	10K
ADM809MART-REEL-7	4.38 V	-40°C to +105°C	9MXX	3K
ADM809JART-REEL	4.00 V	-40°C to +105°C	9JXX	10K
ADM809JART-REEL-7	4.00 V	-40°C to +105°C	9JXX	3K
ADM809TART-REEL	3.08 V	-40°C to +105°C	9TXX	10K
ADM809TART-REEL-7	3.08 V	-40°C to +105°C	9TXX	3K
ADM809SART-REEL	2.93 V	-40°C to +105°C	9SXX	10K
ADM809SART-REEL-7	2.93 V	-40°C to +105°C	9SXX	3K
ADM809RART-REEL	2.63 V	-40°C to +105°C	9RXX	10K
ADM809RART-REEL-7	2.63 V	-40°C to +105°C	9RXX	3K
ADM810LART-REEL	4.63 V	-40°C to +105°C	ALXX	10K
ADM810LART-REEL-7	4.63 V	-40°C to +105°C	ALXX	3K
ADM810MART-REEL	4.38 V	-40°C to +105°C	AMXX	10K
ADM810MART-REEL-7	4.38 V	-40°C to +105°C	AMXX	3K
ADM810JART-REEL	4.00 V	-40°C to +105°C	AJXX	10K
ADM810JART-REEL-7	4.00 V	-40°C to +105°C	AJXX	3K
ADM810TART-REEL	3.08 V	-40°C to +105°C	ATXX	10K
ADM810TART-REEL-7	3.08 V	-40°C to +105°C	ATXX	3K
ADM810SART-REEL	2.93 V	-40°C to +105°C	ASXX	10K
ADM810SART-REEL-7	2.93 V	-40°C to +105°C	ASXX	3K
ADM810RART-REEL	2.63 V	-40°C to +105°C	ARXX	10K
ADM810RART-REEL-7	2.63 V	-40°C to +105°C	ARXX	3K

*Only available in Reels.

ADM809/ADM810—Typical Performance Characteristics

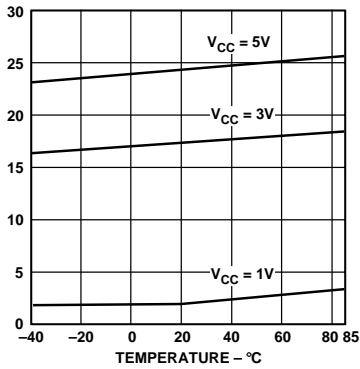

Figure 3. Supply Current vs. Temperature (ADM8_L/M/R/S/T) (No Load)

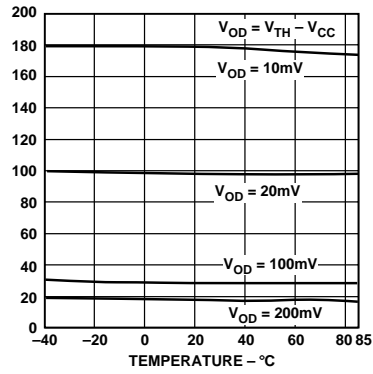

Figure 4. Power-Down RESET Delay vs. Temperature ADM8_L/M

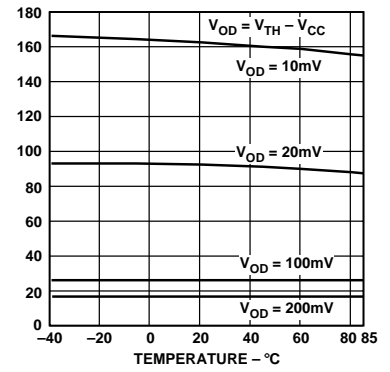

Figure 5. Power-Down RESET Delay vs. Temperature ADM8_T/S/R

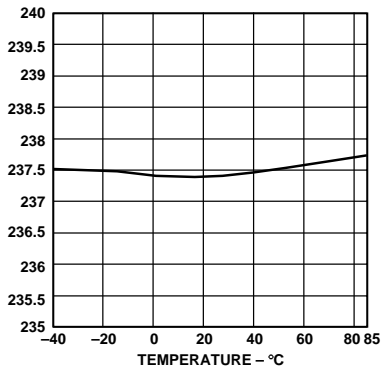

Figure 6. Power-Down RESET Delay vs. Temperature ADM8_R

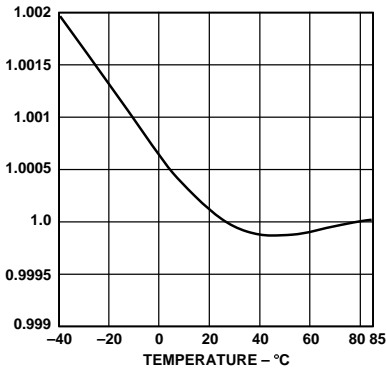

Figure 7. Normalized RESET Voltage Threshold vs. Temperature

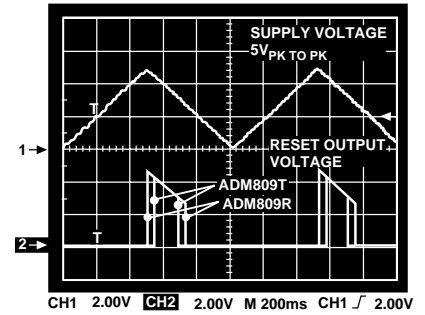

Figure 8. RESET Output Voltage vs. Supply Voltage

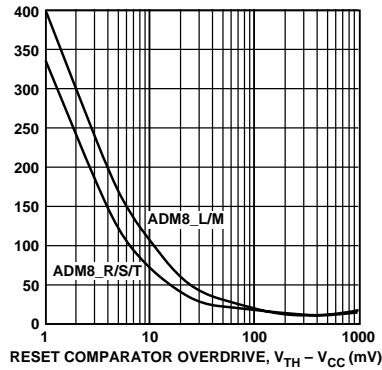

Figure 9. Maximum Transient Duration Without Causing a RESET Pulse vs. RESET Comparator Overdrive

INTERFACING TO OTHER DEVICES OUTPUT

The ADM809/ADM810 Series is designed to integrate with as many devices as possible and therefore has a standard output dependant on V_{CC} . This enables the part to be used in both 3 V and 5 V or any nominal voltage within the minimum and maximum specifications for V_{CC} . Because of this design approach, interfacing this device to other devices is simplified.

ENSURING A VALID RESET OUTPUT DOWN TO $V_{CC} = 0 V$

When V_{CC} falls below 0.8 V, ADM809's RESET no longer sinks current. A high impedance CMOS logic input connected to RESET may, therefore, drift to undetermined logic levels. To eliminate this problem a 100 k Ω resistor should be connected from RESET to ground.

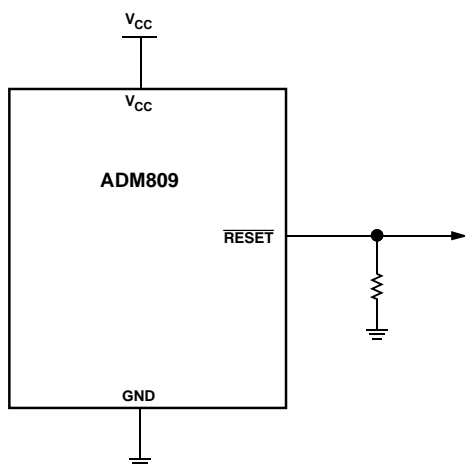

Figure 10. Ensuring a Valid RESET Output Down to $V_{CC} = 0 V$

THE BENEFITS OF A VERY ACCURATE RESET THRESHOLD

In other microprocessor supervisory circuits, tolerances in supply voltages lead to an overall increase in RESET tolerance levels due to the deterioration of the microprocessor RESET circuit's power supply. The possibility of a malfunction during a power failure is greatly reduced because the ADM809 and ADM810 series can operate effectively even when there are large degradations of the supply voltages. Another advantage of the ADM809 and ADM810 series is its very accurate internal voltage reference circuit. These benefits combine to produce an exceptionally reliable Voltage Monitor Circuit.

INTERFACING TO MICROPROCESSORS WITH MULTIPLE INTERRUPTS

In a number of cases it is necessary to interface many interrupts from different devices (i.e., thermal, attitude and velocity sensors). The ADM809 and ADM810 can easily be integrated into existing interrupt-handling circuits (Figure 11) or used as a stand-alone device.

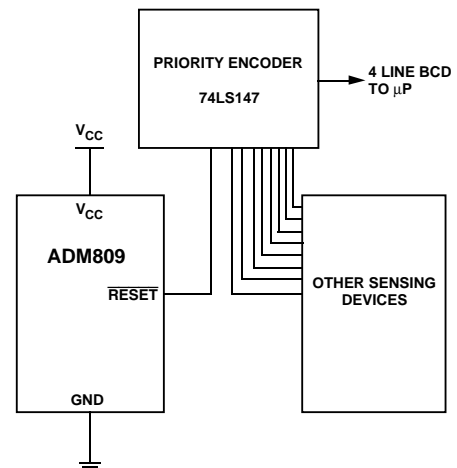

Figure 11. Interfacing to μP s with Multiple Interrupts

ADM809/ADM810

OUTLINE DIMENSIONS

Dimensions shown in inches and (mm).

Surface Mount Package RT-3

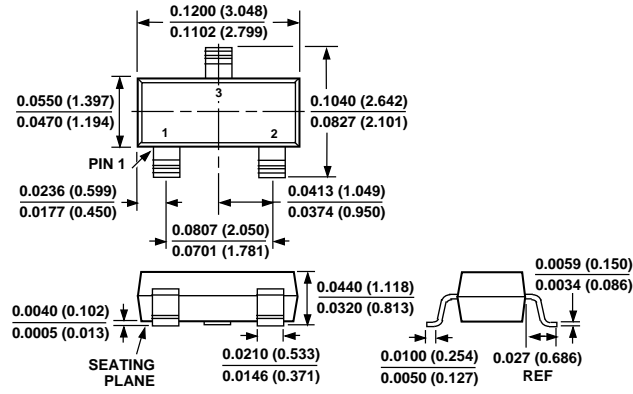

C3047-12-4/97

PRINTED IN U.S.A.