



Evaluation Board AD766X/AD767X

Preliminary Technical Data

EVAL-AD766XCB/AD767XCB

FEATURES

Versatile Analog Signal Conditioning Circuitry
On-Board Reference, Crystal Oscillator and Buffers
16-Bit Parallel Buffered Outputs
Ideal For DSP and Data Acquisition Card Interfaces
Analog and Digital Prototyping Area
EVAL-CONTROL BOARD Compatibility
PC Software for Control and Data Analysis

GENERAL DESCRIPTION

The EVAL-AD766XCB/AD767XCB is an evaluation board for the AD766X/AD767X 16-bit A/D converter family. The AD766X/AD767X family (see ordering guide for product list) is a high speed, successive approximation based architecture with very high performance, low power family of 16-Bit ADCs which operate from a single +5V supply with a 100kSPS to 1MSPS throughput rate range, and a flexible parallel or serial interface. The AD766X/AD767X evaluation board is designed to demonstrate the ADC's performance and to provide an easy to understand interface for a variety of system applications. A full description of the AD766X/AD767X is available in the Analog Devices AD766X/AD767X data sheets and should be consulted when utilizing this evaluation board.

The EVAL-AD766XCB/AD767XCB is ideal for use with either the Analog Devices EVAL-CONTROL BOARD, or as a stand-alone evaluation board. The design offers the flexibility of applying external control signals and is capable of generating 16-bit conversion results on a parallel buffered outputs.

On-board components include an AD780, a +2.5V ultrahigh precision bandgap reference, a signal conditioning circuit with two op-amps and digital logic. The board interfaces with a 96-way connector for the EVAL-CONTROL BOARD, a 20-pin IDC connector for serial output interface, and a 40-pin IDC connector for parallel output data. SMB connectors are provided for the low noise analog signal source, an external master clock and an external start/convert input.

ORDERING GUIDE

Evaluation board Model	Product
EVAL-AD7650CB	AD7650AST
EVAL-AD7660CB	AD7660AST
EVAL-AD7662CB	AD7662YST
EVAL-AD7663CB	AD7663AST
EVAL-AD7664CB	AD7664AST
EVAL-AD7665CB	AD7665AST
EVAL-AD7668CB	AD7668YST
EVAL-AD7671CB	AD7671AST
EVAL-AD7675CB	AD7675AST
EVAL-AD7676CB	AD7676AST
EVAL-AD7677CB	AD7677AST
EVAL-CONTROL BRD2	Controller Board

FUNCTIONAL BLOCK DIAGRAM

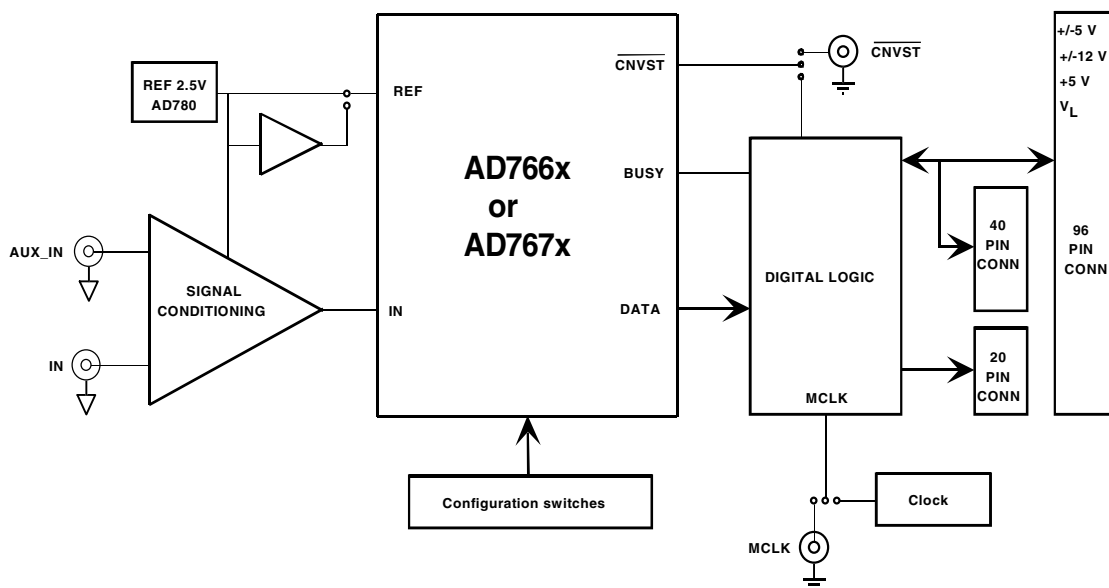

REV. PrK

Information furnished by Analog Devices is believed to be accurate and reliable. However, no responsibility is assumed by Analog Devices for its use, nor for any infringements of patents or other rights of third parties which may result from its use. No license is granted by implication or otherwise under any patent or patent rights of Analog Devices.

One Technology Way, P.O. Box 9106, Norwood, MA 02062-9106, U.S.A.
 Tel: 781/329-4700 www.analog.com
 Fax: 781/326-8703 © Analog Devices, Inc., 2001

EVAL-AD766XCB/AD767XCB

OPERATING THE EVAL-AD766XCB/AD767XCB

The EVAL-AD766XCB/AD767XCB is a four-layer board carefully laid out and tested to demonstrate the specific high accuracy performance of the AD766X/AD767X. Figure 1 shows the schematics of the evaluation board. The layouts of the board are given in :

Top side silk-screen - Figure 2

Top side layer - Figure 3

Ground layer - Figure 4

Shield layer - Figure 5

Bottom side layer - Figure 6

Bottom side silk-screen - Figure 7.

The EVAL-AD766XCB/AD767XCB is a flexible design that enables the user to choose among many different board configurations. A description of each selectable jumper/switch is listed in Table II and the available test points are listed in Table III. Note that the button of a switch in position A (U3 side) defines a low level.

The EVAL-AD766XCB/AD767XCB is configured in factory with 0 to 2.5 V ADC input range for the AD7660, AD7664, and AD7675/7676/7677 and +/-5V for the AD7663/7665/7671; front-end amplifiers U6 and U7 set with a gain of +1, powered through the EVAL-CONTROL BOARD, and the on-board $\overline{\text{CNVST}}$ generation used.

On-board or external $\overline{\text{CNVST}}$ could be used. When an external $\overline{\text{CNVST}}$ signal is applied, this signal should have very low jitter and sharp edges to get the best noise performance of the part. Meanwhile, it is recommended to use the on-board $\overline{\text{CNVST}}$ generation which is done by dividing MCLK signal (20MHZ) by the numbers shown in Table I, which are entered in the software. Activity on BUSY pin of the ADC turns on the LED.

Table I. $\overline{\text{CNVST}}$ GENERATION

Part	Division Factor	Throughput Rate
AD7660	200	100KSPS
AD7662/68	40	500KSPS
AD7663	80	250KSPS
AD7664/50	35	571KSPS
AD7665	35	571KSPS
AD7671	20	1MSPS
AD7675	200	100KSPS
AD7676	35	571KSPS
AD7677	20	1MSPS

Conversion data is available at the output bus BD on U3, on the 40-pin connector P2, and on the 96-pin connector P3. Additionally, BD data is updated on the falling/rising edge of $\overline{\text{DBUSY}}$ and $\overline{\text{BBUSY}}$ on P3, low when BD data is valid are delayed from the BD data by about 20 ns to ease the interface. When either parallel or serial reading mode of the ADC is used, the data is available on this parallel bus. When serial reading mode of the ADC is used, the serial interface signals of the ADC are buffered and available on the 20-pin connec-

tor P1. When slave serial reading mode of the AD766X/AD767X is used, the external serial clock SCLK applied to the ADC is at half the MCLK frequency.

Power Supplies and Grounding

The evaluation board ground plane is separated into two sections: a plane for the digital interface circuitry and an analog plane for the analog input and external reference circuitry. To attain high resolution performance, the board was designed to ensure that all digital ground return paths do not cross the analog ground return paths.

The EVAL-AD766XCB/AD767XCB has three power supply blocks: a single 5V supply VA (SJ1) for the AD766X/AD767X and the reference voltage circuitry, a digital 5V supply VL (SJ2) for the digital interface circuitry and the digital section of the ADC, and a selectable +/-12V (with a possibility of +/-15V with control Brd2) or +/-5V supply for the analog signal conditioning circuitry (SJ3). All supplies are decoupled to ground with 10 μF tantalum and 0.1 μF ceramic capacitors.

Analog Input Ranges

The analog front-end amplifier circuitry U6 and U7 allows flexible configuration changes such as positive or negative gain, input range scaling, filtering, addition of a DC component, use of different op-amp and supplies.

Figure 1 shows the front end op-amp configuration used with the AD7660/7663/7664/7665/7671/7675/7676/7677.

In some applications, it is desired to use a bipolar or wider analog input range like, for instance, $\pm 10\text{V}$, $\pm 5\text{V}$, $\pm 2.5\text{V}$, or 0 to +5V. For the AD76XX parts which do not have directly those input ranges like the AD7660/7664/7675/7676/7677, by simple modifications of the input driver circuitry of the EVAL-AD766XCB/AD767XCB, bipolar and wider input ranges can be used without any performance degradation. Components values required and resulting full-scale ranges are shown in table IV and table V.

In factory, the analog input of U6 is set at mid-scale ($R6=R7=590\Omega$) for the AD7660/7664/7675/7676/7677. For AD7663/7665/7671, R7 is not connected to maintain the input at 0V (mid-scale). This allows a transition noise test without any other equipment. An FFT test can be done by applying a very low distortion AC source.

EVAL-CONTROL BOARD INTERFACE

The EVAL-AD766XCB/AD767XCB interfaces to the EVAL-CONTROL BRD2 through the 96-way connector.

RUNNING THE EVAL-AD766X/AD767XCB SOFTWARE

Software Description

The EVAL-AD766XCB/AD767XCB comes with software for analyzing the AD766X/AD767X. Through the EVAL-CONTROL BRD2 one can perform a histogram to determine code transition noise, and Fast Fourier Transforms (FFT's) to determine the Signal-to-Noise Ratio (SNR), Signal-to-Noise-plus-Distortion (SNRD) and Total-Harmonic-Distortion (THD). The front-end PC software has four screens as shown in Figure 8,9,10 and 11. Figure 8 is the Setup Screen where input voltage range, sample rate, number of samples are selected. Figure 9 is the Histogram Screen, which allows the code distribution for DC input and computes the mean

Figure 10 is the FFT Screen, which performs an FFT on the captured data, computes the Signal-to-Noise Ratio (SNR), Signal-to-Noise-plus-Distortion (SINAD) and total-Harmonic-Distortion (THD). Figure 11 is the time domain representation of the output. When the on-board $\overline{\text{CNVST}}$ generation is used, a synchronous FFT could be achieved by synchronizing the external AC generator with the Fsync signal (TP11) which is an exact division by 2 of MCLK.

Software Installation

- Double-Click on Setup.exe from the CD-ROM and follow the installation instructions.

NOTE: The software runs under Windows 95/98 only.

TABLE II. JUMPER DESCRIPTION

Jumper Designation	Default position with the control board (Factory settings)	Function
JP1	A	Selection of the positive supply of the front-end amplifier U6. When JP1 is in position A, the +12V supply from the control board is applied to JP3 otherwise VS+ on SJ3 is used.
JP2	A	Selection of the negative supply of the front-end amplifier U6. When JP2 is in position A, the -12V supply from the control board is applied to JP4 otherwise VS- on SJ3 is used.
JP3	A	Selection of the positive supply of the front-end amplifier U6. When JP3 is in position A, the +5V supply from the control board is used otherwise JP1 output is used.
JP4	A	Selection of the negative supply of the front-end amplifier U6. When JP4 is in position A, the -5V supply from the control board is used otherwise JP2 output is used.
JP5	not A	Selection of the master clock MCLK signal. When JP5 is in position A, the signal on J4 is used otherwise the on-board 20 MHz $\overline{\text{CNVST}}$ clock is used as a MCLK signal. MCLK signal is used to generate the on-board $\overline{\text{CNVST}}$ signal and the external serial clock SCLK.
JP6	A, U3 side	Selection of RDC (Read during convert). When the button of the switch is close to J4 connector (not A position) and when the serial reading mode is selected, the data are read during conversion otherwise the data are read after conversion. JP6 has no use in parallel reading mode.
JP7	A, U3 side	Selection of PD (Powerdown). When the button of the switch is close to J4 connector (not A position), the ADC is in power-down mode.
JP8	A, U3 side	Spare switch.
JP9	A, U3 side	Selection of RESET. When the button of the switch is close to J4 connector (not A position), the ADC is reset.
JP10	A, U3 side	Selection of $\overline{\text{SER/PAR}}$ (serial/parallel reading mode). When the button of the switch is close to J4 connector (not A position), the data are read in serial mode otherwise the data are read in parallel mode.
JP11	not A, SJ4 side	Selection of $\overline{\text{OC/2C}}$ (coding). When the button of the switch is close to J4 connector (not A position), the ADC uses a straight binary coding otherwise the twos complement coding is used.
JP12	A, U3 side	Selection of WARP. When the button of the switch is close to J4 connector (not A position), the ADC uses the WARP mode which is the fastest one. With the AD7660, JP12 is a spare switch.

EVAL-AD766XCB/AD767XCB

TABLE II. JUMPER DESCRIPTION

Jumper Designation	Default position with the control board (Factory settings)	Function
JP13	A, U3 side	Selection of IMPULSE. When the button of the switch is close to J4 connector (not A position), the ADC uses the IMPULSE mode which is the mode with the lowest power dissipation. With the AD7660, JP13 is a spare switch.
JP14	A, U3 side	TEST1. For factory use only and it is pull down.
JP15	A, U3 side	TEST0. For factory use only and it is pull down.
JP16	A, U3 side	Selection of $\overline{\text{EXT/INT}}$ (use of external or internal serial clock). When the button of the switch is close to J4 connector (not A position) and when the serial reading mode is selected, the data are read with an external serial clock SCLK generated from the master clock MCLK otherwise the data are read with the ADC serial clock. When external serial clock reading mode is selected, MCLK has to be fast enough to be able the read the data properly as explained in the AD766X data sheet. JP16 has no use in parallel reading mode.
JP17	A, U3 side	Selection of INVS $\overline{\text{SYNC}}$ (SYNC active level). When the button of the switch is close to J4 connector (not A position) and when the master serial reading mode is selected, the SYNC signal is active Low. JP17 has no use in parallel reading mode or slave serial reading mode.
JP18	A, U3 side	Selection of INV $\overline{\text{SCLK}}$ (SCLK active edge). When the button of the switch is close to J4 connector (not A position) and when the serial reading mode is selected, INV $\overline{\text{SCLK}}$ is high. JP18 has no use in parallel reading mode.
JP19	not A	Selection of $\overline{\text{CNVST}}$ signal. When JP19 is in position A, the signal on J3 is used otherwise the on-board $\overline{\text{CNVST}}$ generation is used. MCLK signal is used to generate the on-board $\overline{\text{CNVST}}$ signal.
JP20	not A	Selection of REF signal. When JP20 is in position A, the REF is buffered. When JP20 is not in position A, the REF is not buffered.

Table III. EVAL-AD766XCB/AD767XCB Test Points

Test Point	Available Signal
TP1	DGND Digital ground
TP2	DGND Digital ground
TP3	SIG+ ADC Analog input
TP4	AGND Analog ground close to SIG+
TP5	REF ADC Reference input
TP6	BUSY ADC BUSY signal
TP7	$\overline{\text{RD}}$ ADC $\overline{\text{RD}}$ signal
TP8	$\overline{\text{CS}}$ ADC $\overline{\text{CS}}$ signal
TP9	AGND Analog ground close to REF
TP10	$\overline{\text{CNVST}}$ ADC $\overline{\text{CNVST}}$ signal
TP11	F $\overline{\text{SYNC}}$ MCLK divided by 2
TP12	OVDD ADC digital output supply
TP13	DVDD ADC digital core supply
TP14	VANA1 ADC analog supply
TP15	AGND Analog ground close to SIG-
TP16	SIG- ADC Analog input

Table IV. Component values Vs. Input ranges (AD7660)

Input range	R1	R3	R6	R7
$\pm 10\text{V}$	8k Ω	1k Ω	8k Ω	10k Ω
$\pm 5\text{V}$	8k Ω	2k Ω	6.67k Ω	10k Ω
0 to -5V	8k Ω	8k Ω	0 Ω	none

Table V. Component values Vs. Input ranges (AD7664)

Input range	R1	R3	R6	R7
$\pm 10\text{V}$	2k Ω	250 Ω	8k Ω	10k Ω
$\pm 5\text{V}$	2k Ω	500 Ω	6.67k Ω	10k Ω
0 to -5V	1k Ω	1k Ω	0 Ω	none

TESTING METHODS**Histogram**

To perform a histogram test, apply a DC signal to the input. It is advised to filter the signal to make the DC Source noise compatible with that of the ADC. C26 provides this filtering.

AC Testing

To perform an AC test, apply a sinusoidal signal to the evaluation board. Low distortion, better than 100dB, is required to allow true evaluation of the part. One possibility is to filter the input signal from the AC source. There is no suggested bandpass filter but consideration should be taken in the choice. Furthermore, when the full-scale input range is more than a few Vpp, it is recommended that you use the on board amplifier to amplify the signal, thus preventing the filter from distorting the input signal.

Please refer to Figures 8,9,10 and 11 to see the screens of the software.

Software Description

The AD16bit.exe is the software which allows you to analyze different performance characteristics of the AD766X, AD767X, AD97X and AD67X 16-bit ADC family. The software allows you to test the histogram as well as perform different AC tests.

Setup Requirements

- Evaluation Control Board 2 (ADSP2189)
- Evaluation Board
- Power Supply (AC 15V/1A source could be bought from ADI)
- Parallel Port Cable (provided with the evaluation control board)
- AC Source (low distortion)
- DC Source (low noise)
- Bandpass Filter (value based on your signal frequency, low distortion)

USE OF EVAL-AD766XCB/AD767XCB AS STAND-ALONE EVALUATION BOARD

You have the option of using the EVAL-AD766XCB/AD767XCB as a stand-alone evaluation board. This method does not require the control board, nor does it require use of the accompanied software. The digital output will now be available on P1 (20-pin connector, for use in serial mode) or P2 (40-pin connector, for use in parallel mode). Certain modifications have to be made on the board to allow proper operation of the evaluation board. Refer to Table II to obtain the jumper positions for stand-alone operation. When in stand-alone, $\overline{\text{CNVST}}$ could be externally applied or is generated internally according to Table I.

Please refer to Figure 1 to obtain the data output pins on the connectors.

Data is updated on the falling edge of BUSY. $\overline{\text{BCS}}$ and $\overline{\text{BWR}}$ are inputs to the FPGA and are connected to P1 and P2. When $\overline{\text{BCS}}$, CONTROL are low and $\overline{\text{BWR}}$ is high, which is the default value defined by the on-board pull-up/pull-down resistors, the data bus BD available on the P2 connector is enabled.

SUPPLYING THE BOARD FOR STAND-ALONE USE

SJ1 is the analog supply. Connect VA+ to +5V and AGND to GND. SJ2 is the digital supply. SJ2 requires the same values as SJ1, and SJ2 may be connected to SJ1. SJ3 is the supply for the front end amplifier (U6). Connect +12V to VS+, GND to AGND, and -12V to VS-.

EVAL-AD766XCB/AD767XCB

EVAL-BOARD SETTING FOR INPUT CONFIGURATIONS

The AD7663/AD7665 and AD7671 have the ability to operate both unipolar and bipolar range. The available options are +/- 10V, +/- 5V, +/- 2.5V, 0 to 10V, 0 to 5V and 0 to 2.5V.

Table VI shows the required configurations for each input range. (REF = 2.5V). Table VII lists the default settings of the board for all parts.

Table VI. AD7663/7665/7671 Analog Input Configuration

Input Voltage Range	IND(4R)	INC(4R)	INB(2R)	INA(R)
±4 REF	V _{IN}	INGND	INGND	REF
±2 REF	V _{IN}	V _{IN}	INGND	REF
±REF	V _{IN}	V _{IN}	V _{IN}	REF
0 V to 4REF	V _{IN}	V _{IN}	INGND	INGND
0 V to 2REF	V _{IN}	V _{IN}	V _{IN}	INGND
0 V to REF	V _{IN}	V _{IN}	V _{IN}	V _{IN}

Table VII. Default Settings

Component/Part	R7	S9	S10	R48	C40	R47	C39
AD7660	590Ω	None	0Ω	0Ω	None		
AD7663	None	None	0Ω	0Ω	None		
AD7664	590Ω	None	0Ω	15Ω	2.7nF		
AD7665	None	None	0Ω	0Ω	None		
AD7671	None	None	0Ω	0Ω	None		
AD7675	590Ω	0Ω	None	15Ω	2.7nF	15Ω	2.7nF
AD7676	590Ω	0Ω	None	15Ω	2.7nF	15Ω	2.7nF
AD7677	590Ω	0Ω	None	15Ω	2.7nF	15Ω	2.7nF

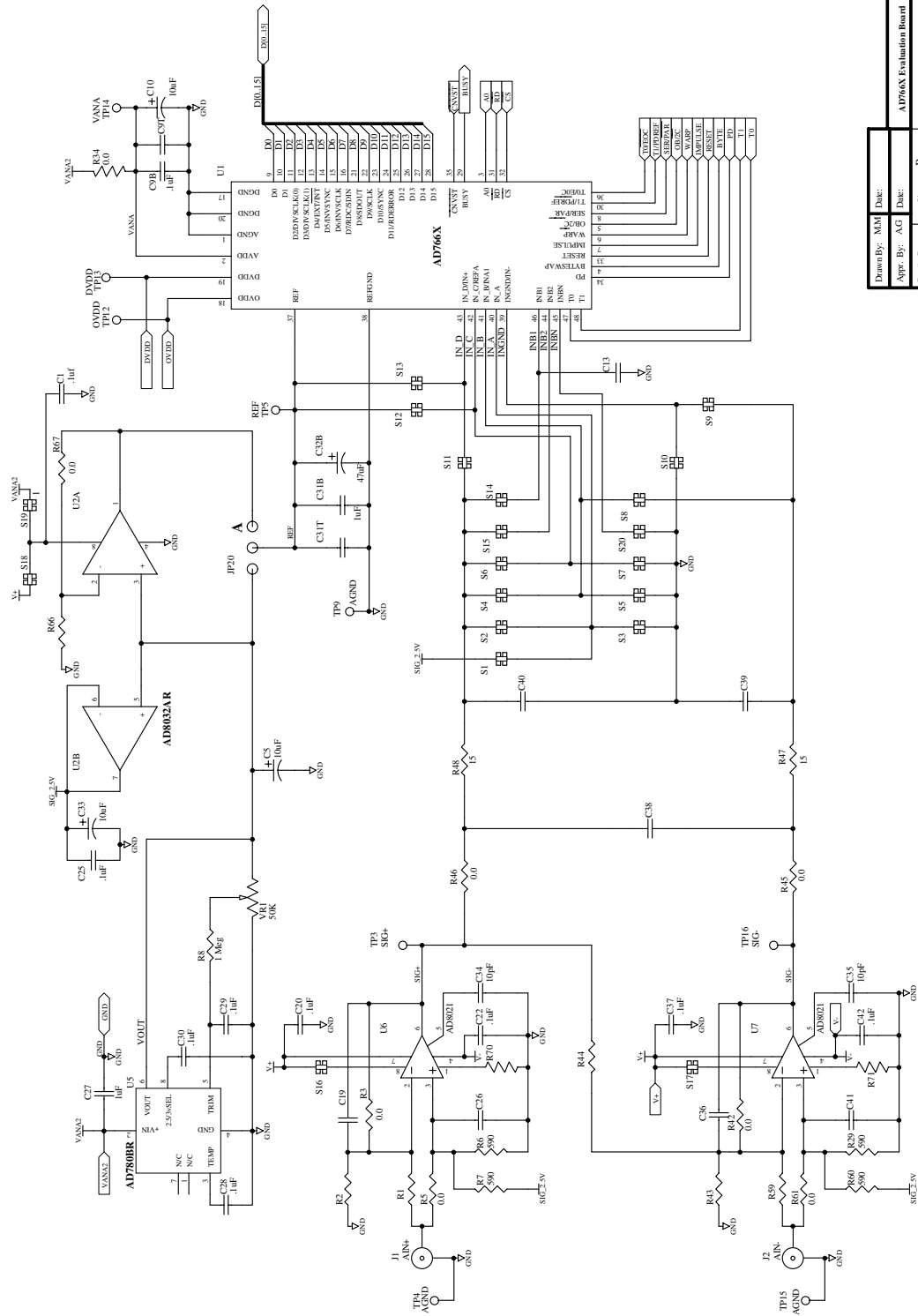

Drawn By: MAM	Date:
Appr. By: AG	Date:
Rev# D	Size B
Sheet 2	of 3
Printing Date: 4-Oct-2001	

AD766X Evaluation Board
ANALOG DEVICES

Figure 1. Schematic

EVAL-AD766XCB/AD767XCB

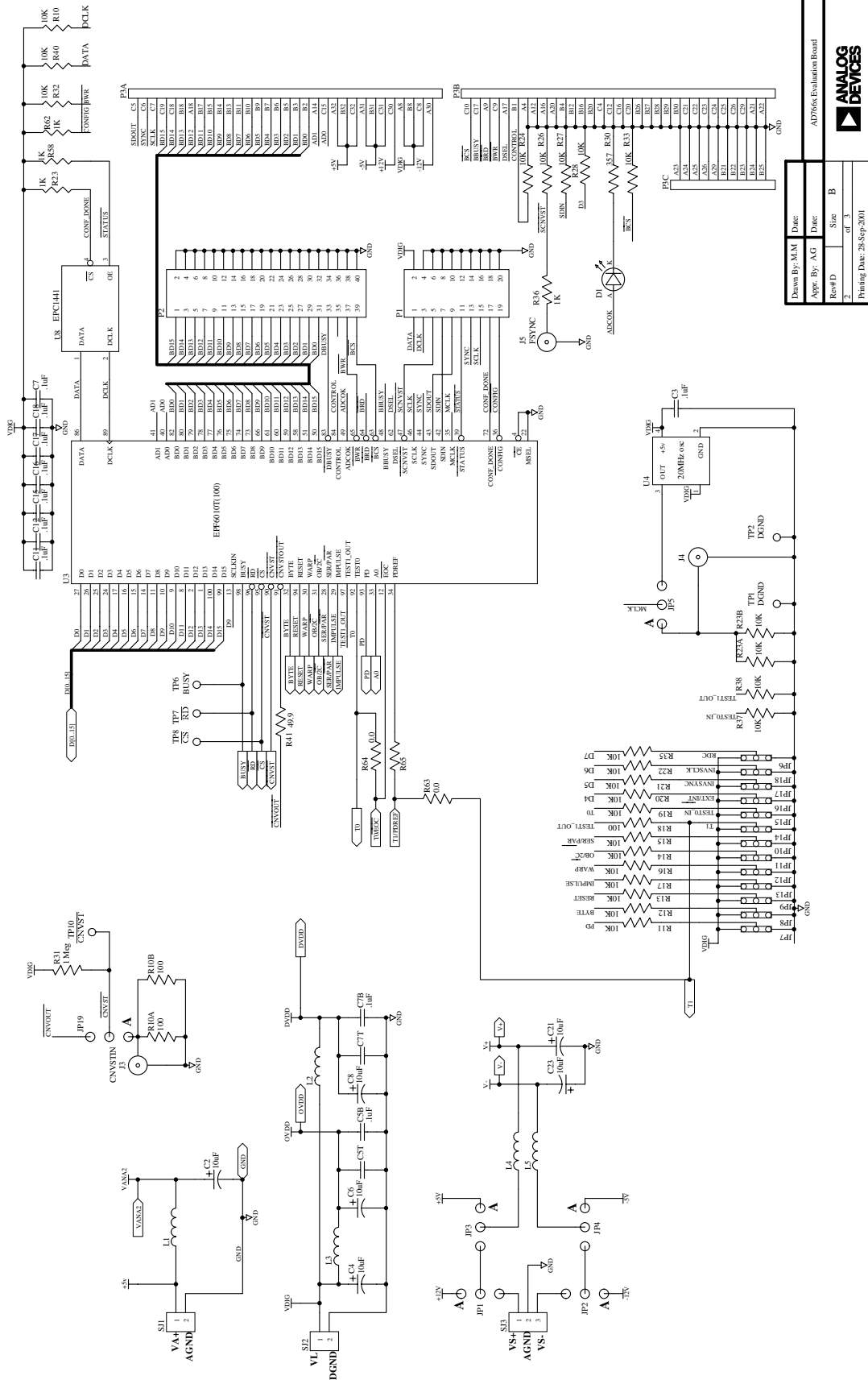

Drawn By: M.M	Date:
Appr. By: A.G	Date:
Rev# D	Size B
2	of 3
Printing Date: 28-Sep-2001	



Figure 1 Schematic

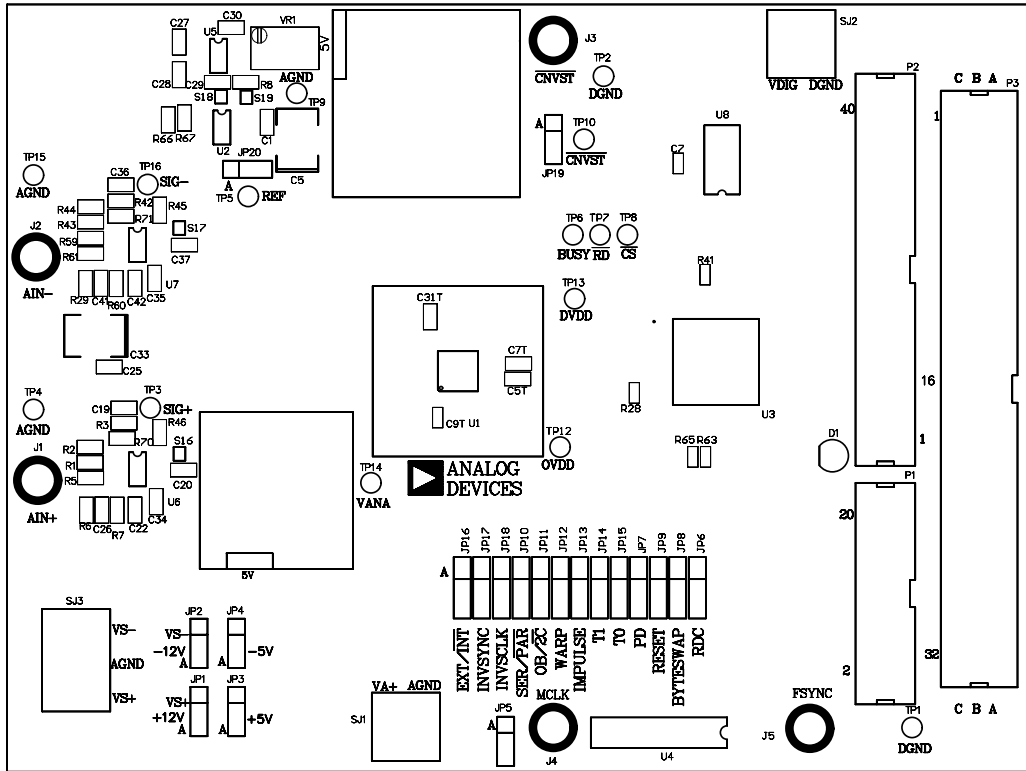

Figure 2. Top side silk-screen (Not to Scale).

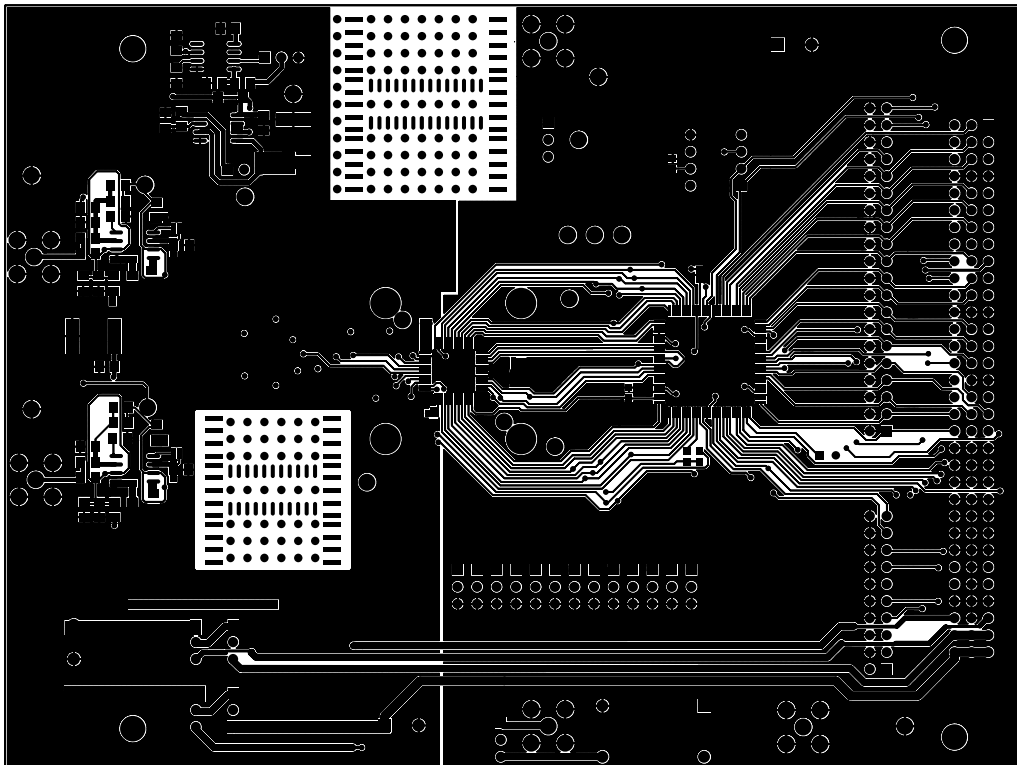

Figure 3. Top side (Not to Scale).

EVAL-AD766XCB/AD767XCB

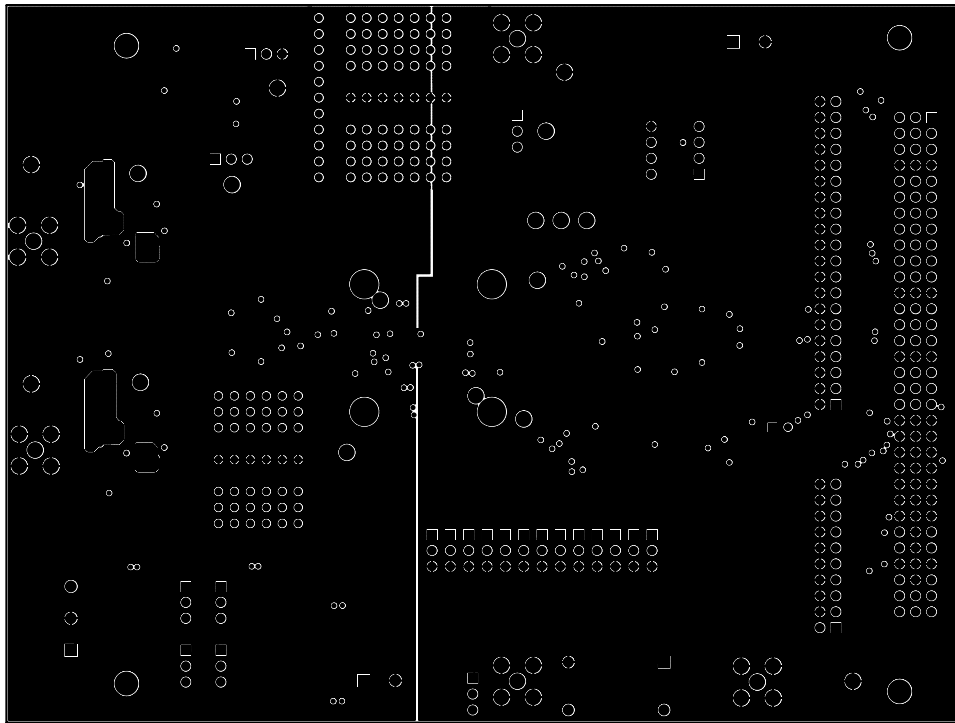

Figure 4. Ground Layer (Not to Scale).

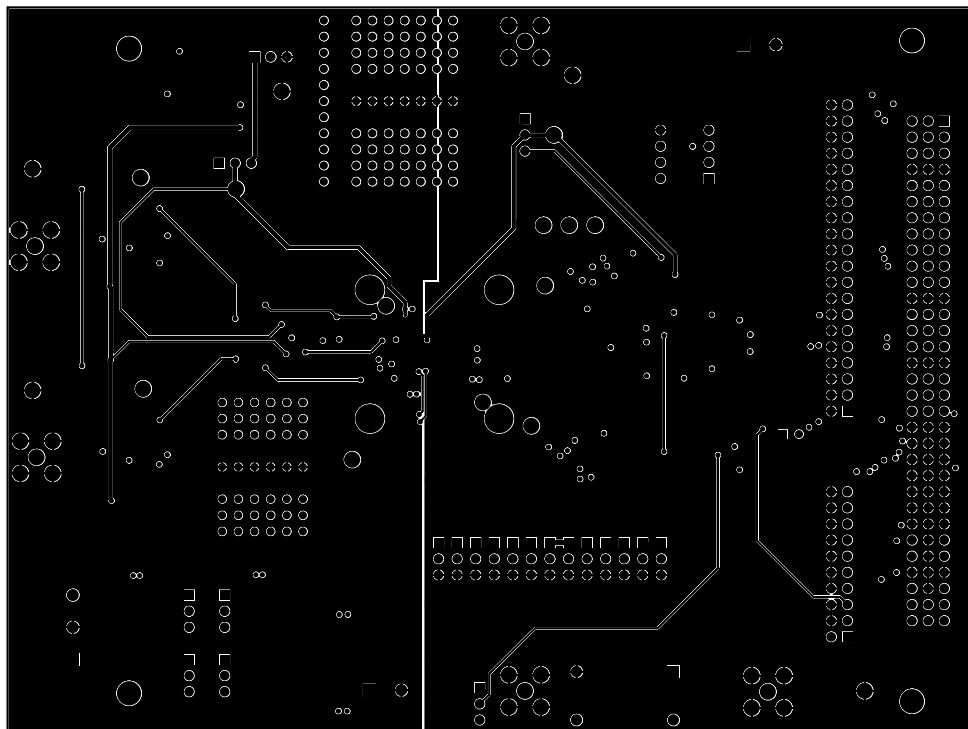

Figure 5. Shield Layer (Not to Scale).

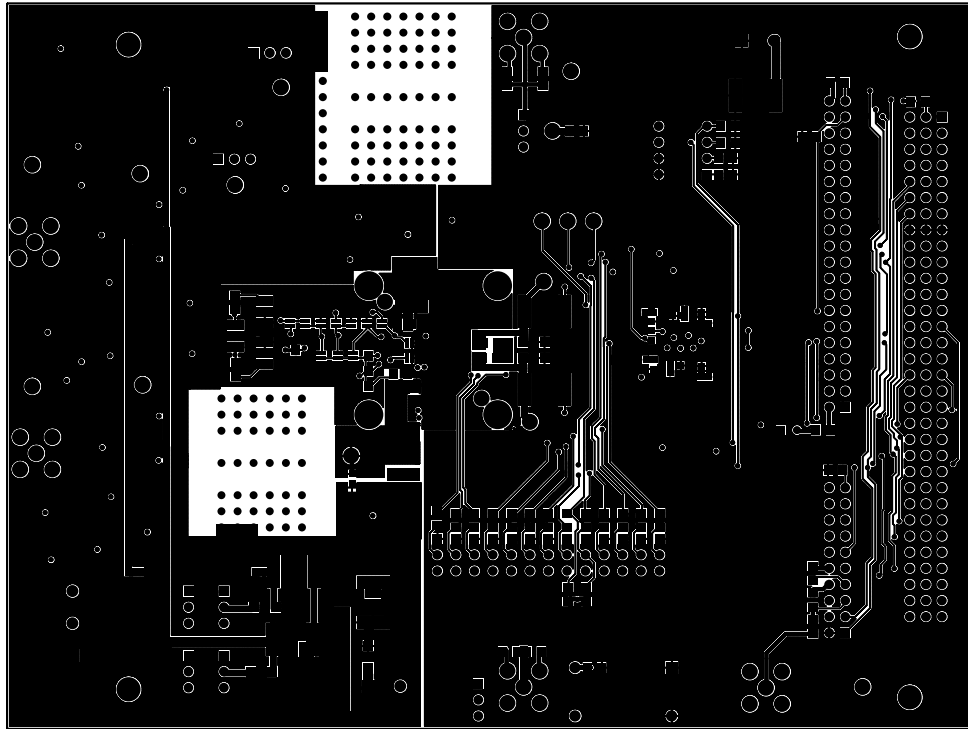

Figure 6. Bottom side layer (Not to Scale).

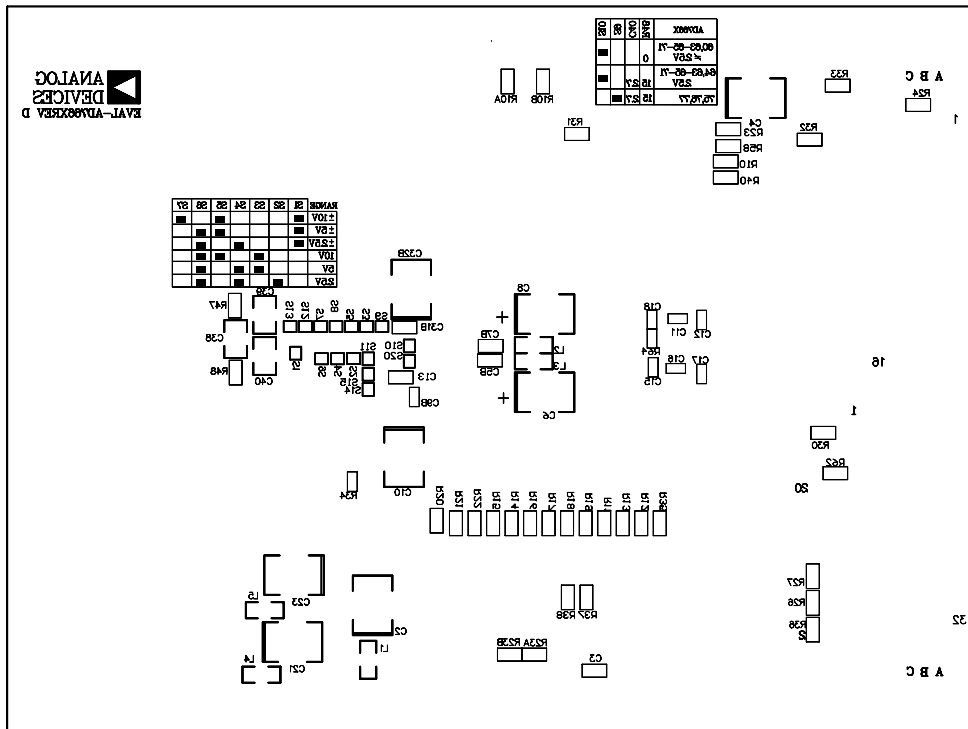

Figure 7. Bottom side silk-screen (Not to Scale).

EVAL-AD766XCB/AD767XCB

1) The Run button starts the software. All input configurations are read by the software after running the software. You will need to press this button first.

2) The part under evaluation is chosen from this menu. The available choices are AD766X, AD97x and AD67x.

3) Input Configurations are chosen here. For the AD766X/AD767X, the available choices are: PwDown, Reset, Interface, Coding, Byte, and Reading.

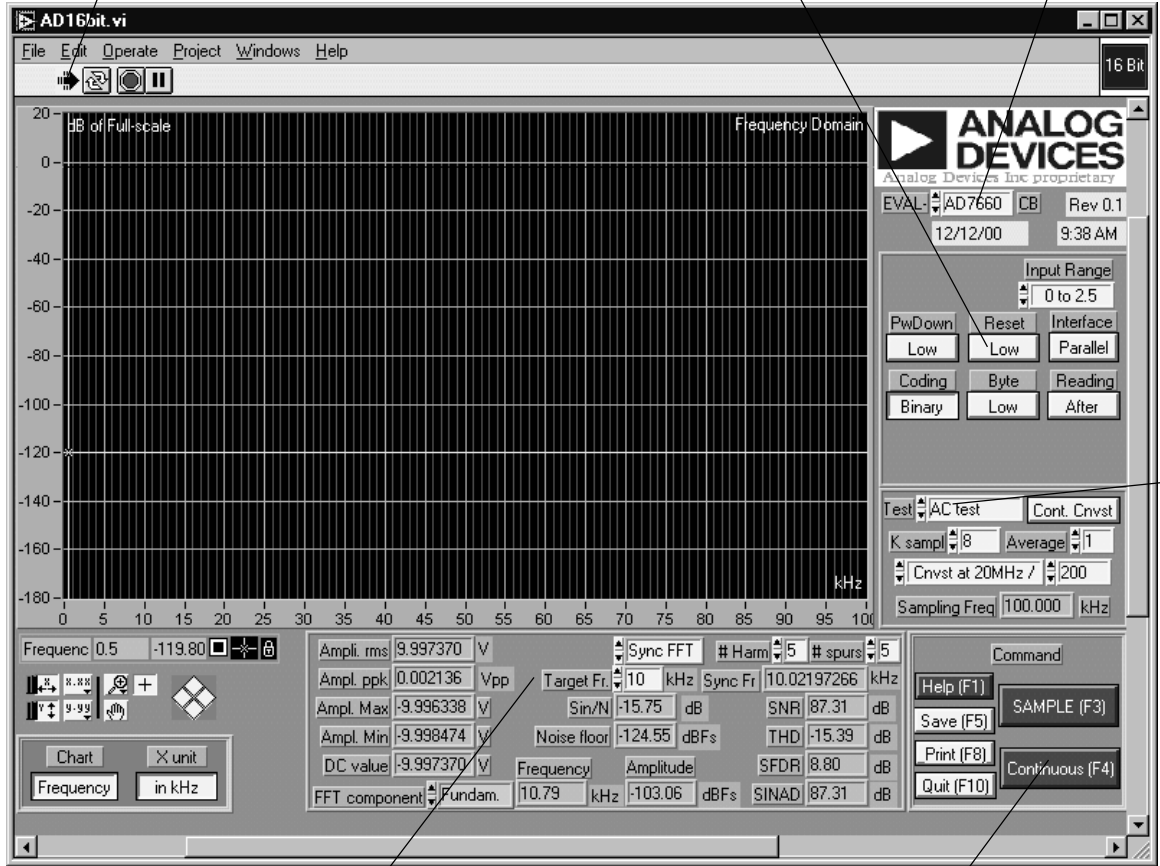

4) The choice of test is made here. You may choose to perform either a Histogram test or an AC test.

Figure 8. Setup Screen

This is the performance window.

5) You may choose to take one sample (Sample,F3), or perform continuous sampling (Continuous,F4). You may also choose the Help, Save, Print or Quit options. The Help menu will show you a description of the functionality of the chosen command.

The results are displayed on this chart. You may also use the cursor (yellow) and drag it to your desired location, where the X-axis value and the Y-axis value will be displayed.

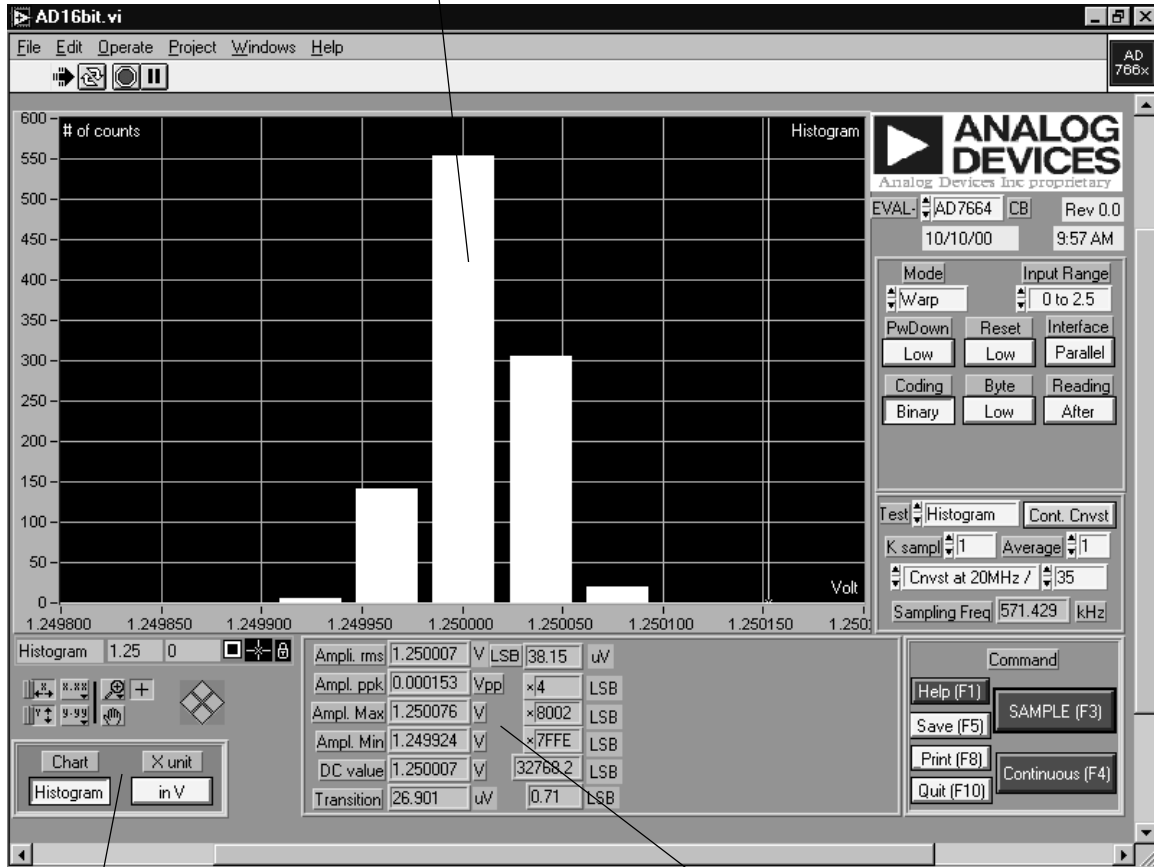

Figure 9. Histogram Screen

This control allows you the choice of display. You have the option of Time or Histogram. You also have the option of changing the X-axis unit

Different measurements are displayed here. The DC value, transition noise, and other values.

EVAL-AD766XCB/AD767XCB

The results are displayed on this chart. You may also use the cursor (yellow) and drag it to your desired location, where the X-axis value and the Y-axis value will be displayed.

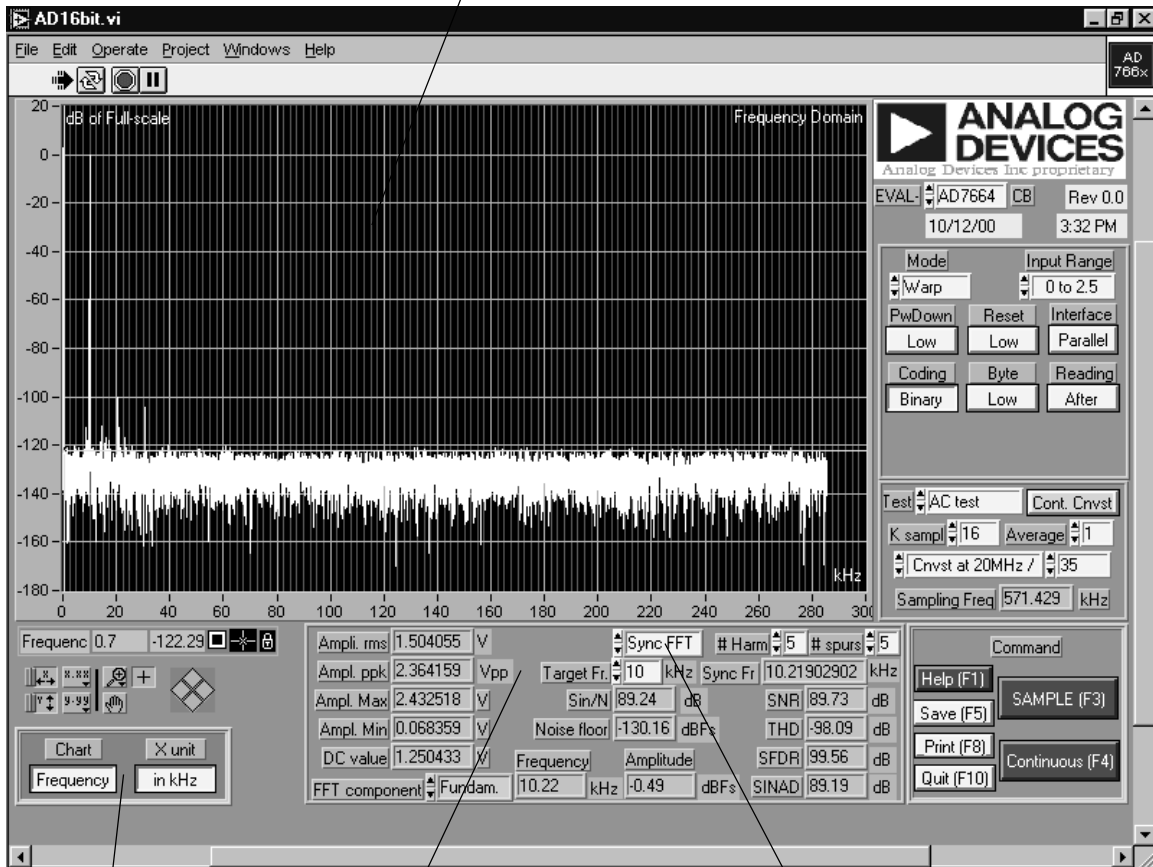

Figure 10. FFT Screen

This is the control that allows you the choice of either time domain or frequency domain. You may also change the X-axis unit here.

AC test results are shown here. You also have the choice of viewing the amplitude of a certain FFT component by changing the FFT component menu.

You may choose either a Kaiser window or a Blackmann-Harris window or a Sync FFT from this menu. . When choosing a Sync FFT, you will need to synchronize your analog source to the sampling frequency. The input frequency should be the value Sync Fr, which is to the right of Target frequency. The process for this is as follows:

1. You Choose a Target frequency
2. The software calculates an integer n based on the target frequency you entered and the sampling frequency, F_{samp}.
3. The software rounds up the value n to the next prime number.
4. The software then calculates the corresponding input frequency (F_{in}) and displays that as Sync Fr.

The equation, (capture window size) is shown below:
 $(1/F_{\text{samp}}) * (\text{number of samples}) = n * (1/F_{\text{in}})$

You can also view the output in the Time domain as shown below.

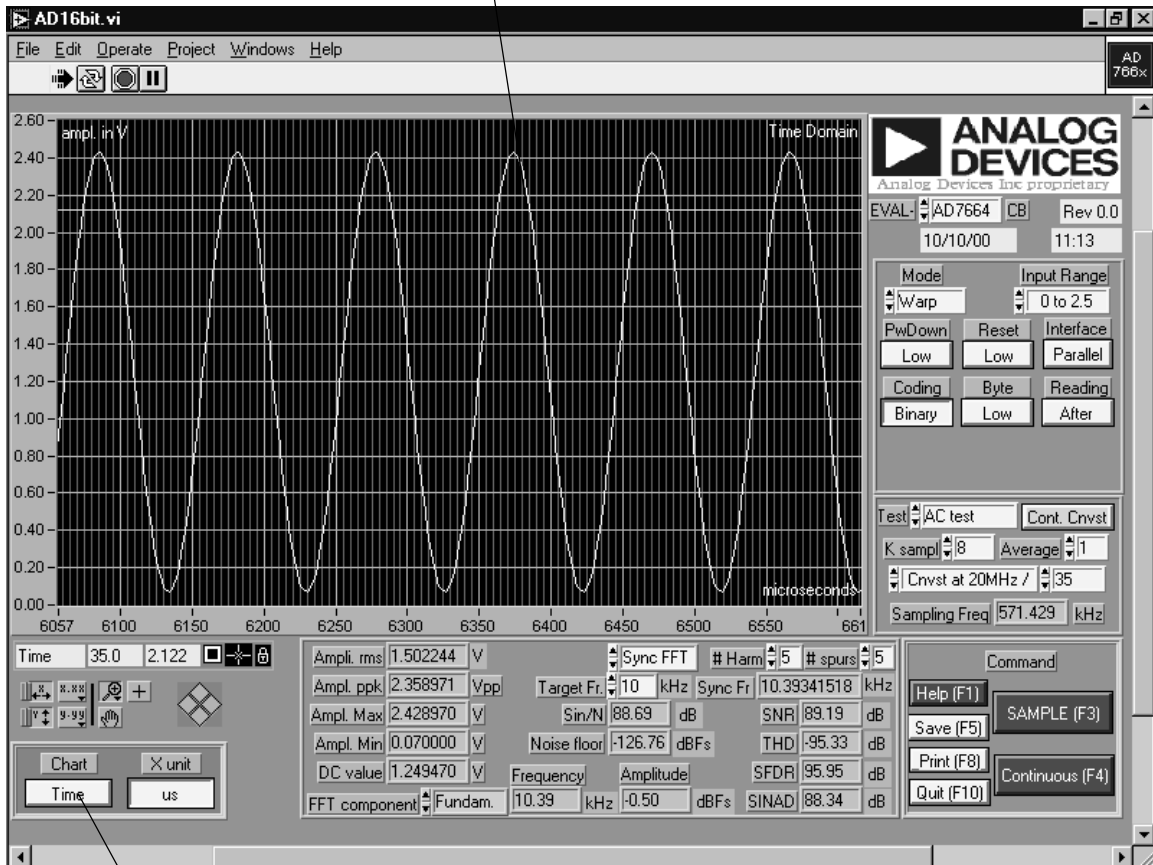

Figure 11. Time-Domain Screen

To view the Time domain, select Time in this menu.