



# High Resolution, Programmable Integrating A/D Converter

## AD1170

### FEATURES

#### Low Nonlinearity:

Integral:  $\pm 0.001\%$

Differential:  $\pm 0.00035\%$

#### Microcomputer-Based Design

Programmable Integration Time: 1 to 350ms  
with Resolution from 7 to 18 Bits

Programmable Output Data Format

Auto-Zeroed Operation and Electronic Calibration  
(No External Trim Potentiometers)

Microprocessor Compatible Interface

#### High Throughput: Over 50 Conversions/Second

for Line Cycle Integration Period

#### High Normal Mode Rejection: 54dB at 60Hz

Small Size: 1.24" x 2.5" x 0.55" max

### APPLICATIONS

Data Acquisition Systems

Scientific Instruments

Medical Instruments

Weighing Systems

Automatic Test Equipment

### GENERAL DESCRIPTION

The AD1170 is a high resolution integrating A/D converter intended for applications requiring high accuracy and high throughput at low cost. A novel conversion architecture provides the user with outstanding accuracy, stability and ease of use.

The AD1170 is a complete microcomputer-based measurement subsystem, composed of three major elements: a highly precise charge balancing converter, a single chip microcomputer, and a custom CMOS controller chip. The AD1170 offers independently programmable integration time (from one millisecond to 350 milliseconds) and data format (offset binary or two's complement, from 7 to 22 bits). The converter is fully auto-zeroed and exhibits a span drift of only 9ppm/ $^{\circ}$ C, assuring stable, accurate readings.

The AD1170 may be interfaced to any microcomputer based system in a memory mapped or I/O mapped fashion via an 8-bit data bus. The AD1170's advanced features are controlled by simple commands sent to it via this bus.

The converter utilizes surface mount technology and is housed in a small 1.24" x 2.5" x 0.55" package. It operates from  $\pm 15V$  dc and +5V dc power.

### PRODUCT HIGHLIGHTS

1. The AD1170, unlike dual slope converters, offers the user the capability of programming the integration time by selecting one of seven preset integration periods or by loading an arbitrary integration period over the interface bus.

### REV. A

Information furnished by Analog Devices is believed to be accurate and reliable. However, no responsibility is assumed by Analog Devices for its use, nor for any infringements of patents or other rights of third parties which may result from its use. No license is granted by implication or otherwise under any patent or patent rights of Analog Devices.

### FUNCTIONAL BLOCK DIAGRAM

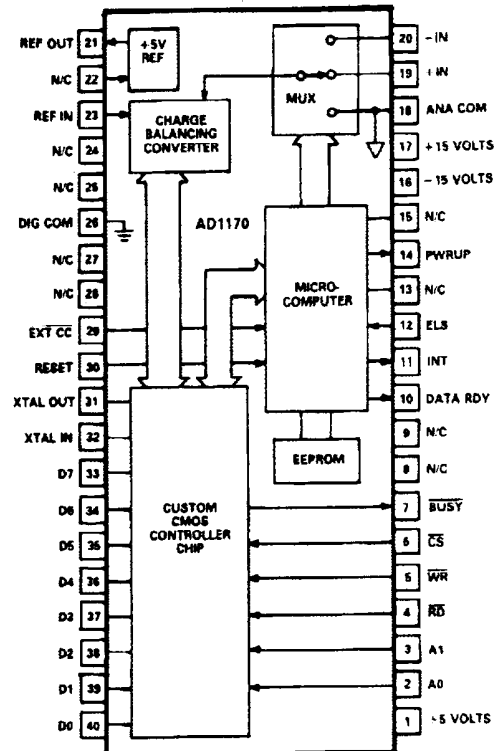

LEAVE N/C PINS UNCONNECTED

2. The AD1170 architecture provides for user programmable data format independent of the integration time. All data is computed to 22-bit resolution and the user may specify any resolution from 7 to 22 bits. Usable resolution will typically be limited to 18-bits due to measurement and calibration noise error.
3. Electronic digital calibration eliminates the need for trim potentiometers. Calibration can be performed at any time by applying an external reference voltage to the input and invoking a calibration command. The calibration data is stored in an internal nonvolatile memory chip.
4. Internal calibration cycles may be programmed to occur whenever the converter is idle, assuring negligible offset drift and only 9ppm/ $^{\circ}$ C span drift.
5. The conversion rate is greater than 50 conversions per second when programmed for 60Hz line cycle integration. The maximum conversion rate is greater than 250 conversions per second, using a one millisecond integration period.

One Technology Way, P.O. Box 9106, Norwood, MA 02062-9106, U.S.A.  
Tel: 617/329-4700 Fax: 617/326-8703 Twx: 710/394-8577  
Telex: 924491 Cable: ANALOG NORWOODMASS

# AD1170—SPECIFICATIONS (typical @ +25°C, V<sub>S</sub> = +15V, V<sub>R</sub> = +5V unless otherwise specified.)

Model	Min	Typ	Max	Units
<b>RESOLUTION<sup>1</sup></b>	7		18	Bits
<b>ACCURACY</b>				
Integral Nonlinearity <sup>2</sup>		± 0.001		% SPAN
<b>THROUGHPUT RATE<sup>3</sup></b>				
Time (Integrate) = 1ms	250			conv/S
Time (Integrate) = 16.667ms	50			conv/S
Time (Integrate) = 100ms	9			conv/S
<b>DIFFERENTIAL NONLINEARITY</b>				
T (int) @ T (cal)				
1ms 10ms		± 0.01		% SPAN
16.667ms 100ms		± 0.0008		% SPAN
300ms 300ms		± 0.00035		% SPAN
<b>STABILITY</b>				
Span		± 9		ppm SPAN/°C
<b>POWER SUPPLY REJECTION RATIO</b> (Span Error vs. Analog Supply Voltage)		60		ppm of Reading/V
<b>INPUT CHARACTERISTICS</b>				
Analog Input Range				
dc	-5		+5	V
dc Plus Normal-Mode Voltage	-6		+6	V
Absolute Maximum (Without Damage)	-30		+30	V
Normal-Mode Rejection				
@ 60Hz		54		dB
@ 50Hz		60		dB
Input Bias Current		10		nA
Input Impedance		100		MΩ
<b>REFERENCE</b>				
Output Voltage		5		V dc
Output Current		2		mA
Input Range	4.5		5.5	V dc
<b>DIGITAL LEVELS</b>				
Inputs				
Low			0.8	V
High	2.0			V
Outputs				
Low (@ 4mA)			0.45	V
High (@ 100µA)	2.4			V
<b>WARMUP TIME</b>				
to 60ppm SPAN		5		min
to 20ppm SPAN		15		min
<b>POWER REQUIREMENTS</b>				
+V <sub>S</sub> and -V <sub>S</sub>	9	15	18	V
+V <sub>D</sub>	4.75	5	5.25	V
Supply Current Drain @ ± 15V		12		mA
@ +5V		110		mA
<b>TEMPERATURE RANGE</b>				
Rated Performance	0		+70	°C
Storage	-25		+85	°C
<b>SIZE</b>	1.24" × 2.5" × 0.55" max (31.4 × 63.5 × 14.0) mm			

## NOTES

<sup>1</sup>The usable resolution is limited by noise, which is largely determined by the integration period and calibration period. Consult the chart in Figure 4 for typical peak-to-peak noise versus integration and calibration period.

<sup>2</sup>The integral linearity is defined as the deviation from a straight line drawn between the endpoints of the converter. This specification is independent of gain and/or offset errors.

<sup>3</sup>Throughput Rate is calculated by the formula:  $\frac{1000}{T_{(int)}} = 3 \text{ milliseconds}$  = minimum conversions/second

Where T<sub>(int)</sub> is expressed in number of milliseconds.

Specifications subject to change without notice.

IBM PC/XT/AT<sup>®</sup> compatible evaluation board, AC5004 (see last page of this data sheet for description).

<sup>®</sup>IBM PC/XT/AT is a trademark of International Business Machines Corp.

## OUTLINE DIMENSIONS

Dimensions shown in inches and (mm).

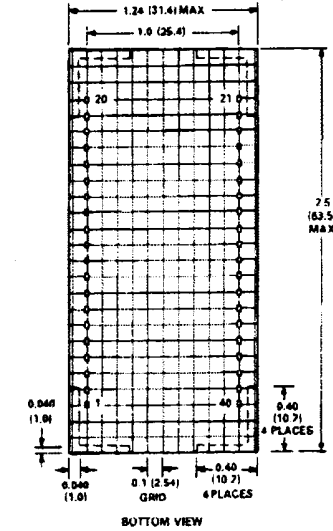
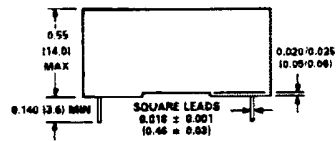

CAUTION: OBSERVE PROPER PLUG-IN POLARITY TO PREVENT DAMAGE TO CONVERTER

## PIN DESCRIPTIONS

PIN	SIGNAL	DESCRIPTION
1	+5V	Digital Power Supply
2,3	AD, A1	Address Control Lines
4	RD	Read Data Strobe
5	WR	Write Data Strobe
6	CS	Chip Select
7	BUSY	When Low, Indicates Device Busy When High, Indicates Device Ready for Command
10	DTA RDY	When High, Indicates That Data From Most Recent Conversion Command is Ready
11	INT	When High, Indicates Device is Currently Integrating Input Signal. Goes Low to Indicate Integration Completes
12	ELS	External Line Sample Input. Used with ELS Command to Sense an Externally Provided Sample of the Line Frequency
14	PWR UP	When High, Indicates Power Up Initialization in Progress
16	-15V	Negative Analog Power Supply
17	+15V	Positive Analog Power Supply
18	ANA COM	Analog Common; the Reference Point for Analog Power Supplies
19	+IN	Positive Signal Input
20	-IN	Negative Signal Input
21	REF OUT	Internal +5V Reference Output
23	REF IN	Reference Input; Normally Connected to Ref Out
26	DIG COM	Digital Common; the Reference Point for the Digital Power Supply
29	E <sub>1</sub> CC	External Convert Command Input
30	RESET	Reset Input; Usually Connected to an RC Network for Automatic Reset Upon Power Up
31,32	XTAL QUIT, XTAL IN	Connections for 12MHz Crystal (Series Resonant, 3611 ESR). Alternatively, Xtal In May Be Driven From an External 12MHz Logic Signal
33-40	D7-D0	Bidirectional Data Bus
8, 9, 13, 15, 22, 24, 26, 27, 28		DO NOT CONNECT

**FACTORY DEFAULT SETTINGS**

The AD1170's internal nonvolatile memory stores various A/D parameters as programmed by the user (such as the integration period, output data format, calibration coefficient, etc.). The AD1170 is calibrated at the factory with the following default settings:

- FORMAT: 16-bit, offset binary
- DEFAULT T(int): 16.667 milliseconds (code 2)
- DEFAULT T(cal): 100 milliseconds (code 4)

**AD1170 ARCHITECTURAL OVERVIEW**

The AD1170 is a complete microcomputer-based measurement subsystem, containing three major elements: a highly precise charge balancing converter, a single chip microcomputer, and a custom CMOS controller chip.

The heart of the measurement technique is the charge balancing converter (essentially a voltage to frequency converter). This converter measures the input signal by balancing a proportional current against a train of precisely controlled reference current pulses using an integrator. The microprocessor, together with the counting and gating circuitry within the CMOS controller chip, measures the period of the reference current pulses by interpolating them using a 12MHz clock signal. The resulting

data is converted to binary representation by the use of floating point firmware routines within the microprocessor.

When the AD1170 is triggered to perform a conversion, two separate phases are performed: first, an integration phase, where the input signal is actually measured, and then a computation phase, where the data from the integration phase is processed, along with both the volatile and nonvolatile calibration data, and formatted for output as the user desires.

The duration of the integration phase can be programmed by the user, and may be as short as one millisecond, or as long as 350 milliseconds. The computation phase always lasts approximately three milliseconds and commences immediately after the integration phase is over. Therefore, the total conversion time will equal the user programmed integrate time plus a fixed 3 milliseconds. Status signals are provided to indicate when the data is ready and when the converter may be retriggered for the next conversion.

For maximum stability, the AD1170 periodically calibrates itself by performing measurements upon a zero input signal and a full-scale signal provided by the internal reference. This technique cancels any drift within the charge balancing converter itself, resulting in negligible offset drift, and gain stability equal to that of the reference. Calibration cycles may be programmed to take place whenever the AD1170 is idle, or they may be invoked under system control.

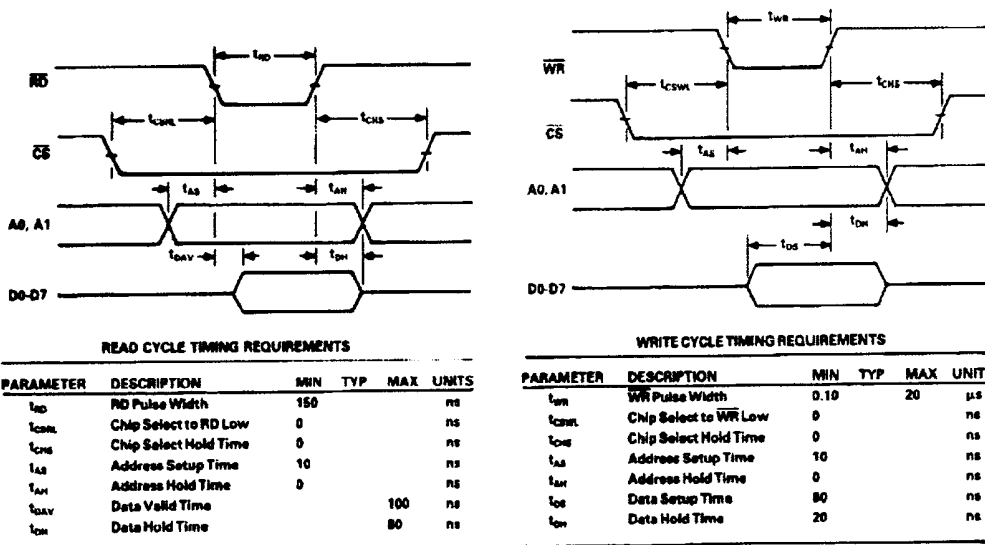

Figure 1. Timing Diagrams and Requirements

# AD1170

The AD1170 contains no internal trims; its span accuracy is factory calibrated by using the ECAL (Electronic CALibration) feature. This feature is a firmware routine which measures an externally applied reference voltage, compares it to the internal reference voltage, and computes a span correction factor which is stored in nonvolatile memory. The correction factor is then applied to all subsequent measurements, thereby compensating for the reference error. The ECAL function may be invoked by the user at any time, thereby replacing the usual trim potentiometer with a totally electronic calibration capability.

## UNDERSTANDING THE AD1170 SPECIFICATIONS

The AD1170, because of its unique conversion technique, is specified quite differently from more conventional integrating converters. The following sections will help the user to understand where the sources of error are, and how to extract the best possible performance from the converter.

There are two primary sources of error in the AD1170: integral nonlinearity of the charge balancing converter, which influences all conversions equally, regardless of the integration period and calibration period; and the noise error of the measurement/calibration process, which is a function of the integration period and calibration period as selected by the user.

### INTEGRAL NONLINEARITY

The integral nonlinearity of the charge balancing converter (CBC) is  $\pm 10\text{ppm}$  ( $\pm 0.001\%$ ) of Span. This specification is an "endpoint" nonlinearity measurement; i.e., the typical deviation seen from a straight line drawn between the CBC output at  $-5$  volts and its output at  $+5$  volts. This specification excludes any gain or offset error.

If the converter was externally calibrated at its end points ( $-5$  volts and  $+5$  volts), then the integral nonlinearity would also be the relative accuracy of the converter. This is not the case in the AD1170, however, because calibration is performed internally at  $0$  and  $+5$  volts, rather than  $-5$  and  $+5$  volts. This calibration technique, superimposed upon the integral nonlinearity of the CBC, results in the curve shown in Figure 2.

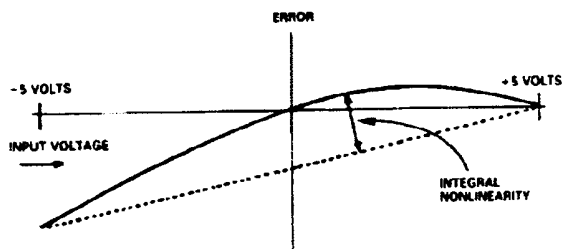

Figure 2. Relative Accuracy and Integral Nonlinearity when Calibrated

T(cal) =	1ms	10ms	16.7ms	20ms	100ms	166.7ms	300ms	CAL DISABLED	UNITS
T(int) = 1ms	208	115	115	114	113	112	111	110	± ppm of SPAN
10ms		24	18	16	13	13	13	12	
16.7ms			14	13	8	8	8	8	
20ms				12	7	7	7	7	
100ms					4.0	4.0	3.5	3.5	
166.7ms						4.0	3.5	3.5	
300ms							3.5	3.5	

Figure 4. Typical Peak-to-Peak Noise (in ppm Span) Versus T(int) and T(cal)

As shown in the diagram, the calibration technique tends to exaggerate the relative error at the negative end of the scale, and reduce the error between  $0$  and  $+5$  volts. This characteristic happens to be most beneficial when using the AD1170 in systems where the input comes from a sensor whose signal is mostly positive, such as a thermocouple.

For systems where the user desires to minimize the relative error equally across the whole span of the converter, it is possible to intentionally introduce a span error during the ECAL procedure, as shown in Figure 3. This scheme sacrifices positive full-scale accuracy in order to minimize negative full scale error. The net result is a relative accuracy equal to the integral nonlinearity.

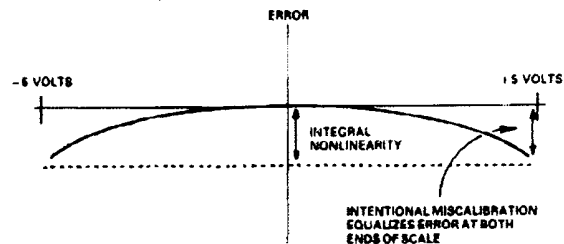

Figure 3. Relative Accuracy with Intentional Span Error at +F.S.

In both cases the accuracy of the input offset (which is servo controlled) is not compromised.

### MEASUREMENT/CALIBRATION NOISE

Measurement noise refers to the conversion-to-conversion uncertainty caused either by mathematical truncation or device noise.

Calibration noise is actually the measurement noise resulting from the calibration process. The converter stabilizes itself by performing internal measurements of the reference, and of ground; these measurements have the same uncertainty due to noise as does the normal measurement process.

The measurement and calibration noise error of the AD1170 determines the differential linearity, or useable resolution, of the converter. This parameter determines the useable resolution because it defines what codes can be seen through the noise. The specified value is the amount of error, in either direction from the average reading, which will not be exceeded for 95% of all conversions. This parameter, as in all integrating converters, is a function of the integration time; long conversions result in very high resolution, while short conversions provide lower resolution. In the AD1170, all internal computations are always carried out to 22-bit resolution, but useable resolution is limited by the peak-to-peak noise, as determined by T(cal) and T(int).

The chart shown in Figure 4, illustrates the typical peak-to-peak noise (in ppm Span) versus T(int) and T(cal). These numbers can be used to indicate how much useable resolution can be

expected under a given set of operating conditions. For example, a peak-to-peak noise of  $\pm 8$ ppm is approximately analogous to a flicker of  $\pm 0.5$ LSB at 16 bits of resolution. Under these conditions, a user could set the default format for the AD1170 to 16-bit resolution, and observe no more than  $\pm 1/2$ LSB of differential error. See Table I for conversion of typical peak-to-peak noise to Differential Nonlinearity and Useable Resolution.

The chart in Figure 4 may also be used to determine the minimum effective calibration time for a specified integration period; the noise contributions of both the measurement cycle and the calibration cycle combine as the "root sum square", and the combined effect tends to asymptotically approach a baseline value determined by the shorter of the two. For example, a  $T(\text{cal})$  greater than 10 milliseconds does little or nothing to improve the noise performance for conversions using a  $T(\text{int})$  of 1 millisecond.

NOISE (ppm Span)	RESOLUTION AT 1/2LSB DNL ERROR (NO. OF BITS)	RESOLUTION AT 1LSB DNL ERROR (NO. OF BITS)	DIFFERENTIAL NONLINEARITY (% Span)
244	11	12	0.024
122	12	13	0.012
61	13	14	0.006
31	14	15	0.003
15	15	16	0.0015
8	16	17	0.00076
4	17	18	0.00038
2	18	19	0.00019

Table 1. Conversion of Noise Error to DNL and Usable Resolution

**SIGNAL INPUT CONNECTIONS**

The AD1170 has both a positive input pin (+IN) as well as a negative input pin (-IN), but the AD1170 input is not a true differential input. The negative input pin is an input used during calibration cycles to establish the zero reference. In applications with static ground offsets, the -IN pin may be used as a ground sense input, to sense a signal reference point which is offset from analog common by a small differential. Both the -IN and +IN signals must have a bias current path back to analog common. Figure 5 illustrates the proper use of the input signal connections.

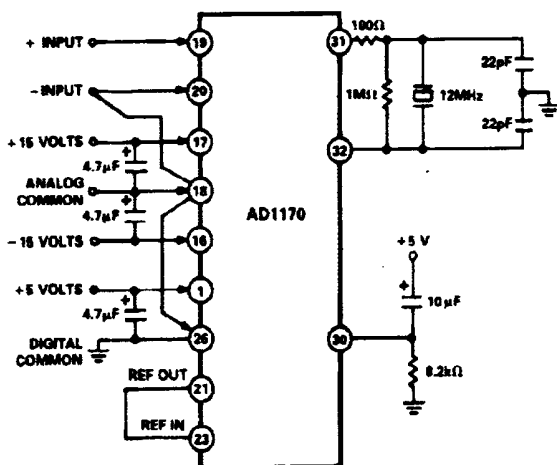

Figure 5. Input, Power, Reset, and Clock Connections

**RESET**

A reset sequence must be accomplished after power-up and before any access to the converter. The RESET line initializes the internal logic of the AD1170. This line may be driven from an external source, such as may exist in most computer based systems, or it may be connected to a simple RC circuit which will automatically invoke a reset sequence at power-up. Figure 5 illustrates the recommended circuit.

When driving the RESET line from an external source, the line must be held high for at least 2 microseconds after the oscillator is running and stable (typically 300 microseconds after power is applied) in order to assure a proper reset.

**CLOCK**

The AD1170 requires a 12MHz clock for operation. This clock may be supplied by connecting the XTAL OUT and XTAL IN pins to a 12MHz crystal, along with two resistors and two capacitors as shown in Figure 5.

The user may also supply a 12MHz logic signal from an external source, such as may be available in the user's system. In this case, the external clock should be applied to the XTAL IN pin, and the XTAL OUT pin should remain unconnected.

**POWERING THE AD1170**

For best performance, the user should pay careful attention to proper power supply bypassing, as well as grounding. Analog common and digital common are not connected internal to the module, but must be connected externally. Figure 5 illustrates the proper connection of power and ground to the AD1170<sup>1</sup>.

**REFERENCE CONNECTIONS**

The internal +5 volt reference of the AD1170 is brought out to Pin 21 of the module; for normal operation, it should be connected to the reference input (Pin 23).

An external reference voltage of from 4.5 to 5.5 volts may be applied to the reference input (Pin 23), and the reference output may remain unconnected. The data will be ratiometric to that reference. The input impedance of the reference input is approximately 16K ohms. The reference input is not dynamic; any external reference voltage must be an essentially static DC signal.

**INTERFACING TO THE AD1170**

The AD1170 contains an eight-bit microprocessor compatible interface structure, including control lines. It can be interfaced to any microprocessor-based system in either a memory mapped or I/O mapped mode, and occupies four successive bytes of read/write address space, as shown in Figure 6.<sup>1</sup>

	$\overline{\text{CS}}$	$\overline{\text{RD}}$	$\overline{\text{WR}}$	A1	A0	FUNCTION
	H	X	X	X	X	Device Not Selected
	L	H	L	H	H	(Unused)
WRITE	L	H	L	H	L	Parameter 2 Write
	L	H	L	L	H	Parameter 1 Write
READ	L	H	L	L	L	Command Write
	L	L	H	H	H	High Data Read
	L	L	H	H	L	Mid Data Read
	L	L	H	L	H	Low Data Read
	L	L	H	L	L	Status Read

X = DON'T CARE

Figure 6. Control Functions

<sup>1</sup>Attempting to READ and WRITE at the same time ( $\overline{\text{RD}}$  and  $\overline{\text{WR}}$  set low) may alter the contents of the internal nonvolatile memory.

# AD1170

The AD1170 is controlled by writing a command into the lowest byte of the device image. Upon receipt of the command byte, the BUSY line is set low, indicating that command interpretation is in progress. The BUSY line returns high, following command interpretation and a command dependent execution time. This signals that the command execution has been completed, and another command may now be written. The logical inverse of the BUSY line is available in the STATUS byte for use in polling. See the section below about THE STATUS BYTE.

When the command requires one or two parameters, in addition to the command byte, they must be written into the second and third parameter bytes of the image *before* writing the command byte. This is because writing the command byte triggers the microprocessor to begin command interpretation.

Following the execution phase of any command, the CMD ERR bit in the STATUS byte will indicate acceptance or rejection of the command. When set, this bit indicates that there was a contextual or syntactic error in the command or parameters.

Conversions may be initiated either by bus command, or by a high to low transition of the EXT CC line<sup>1</sup>. Externally triggered conversions behave in the same way as bus triggered conversions, except that the BUSY line and the BUSY bit in the status word remain inactive; the end of execution of externally triggered conversions must be determined by examination of the DTA RDY line or the DTA RDY bit in the STATUS word.

## THE STATUS BYTE

The lowest readable byte of the device image is the STATUS byte; it contains six bits of information about the current status of the AD1170. This byte may be examined by the host processor at any time. The individual bits in the status byte (see Figure 7) are assigned the following functions:

- BIT0** The BUSY bit is an inverted version of the signal on Pin 7 of the module. When low, it indicates that the AD1170 is ready to receive a command. When high, it indicates that the AD1170 is busy executing the last command. Any commands loaded while the BUSY signal is high will be ignored.
- BIT1** The DTA RDY bit (also available on Pin 10 of the module) goes high to indicate that the data from the most recent conversion is available in the LOW DATA, MID DATA, and HIGH DATA registers. This bit is cleared at the start of the next conversion. It may also be cleared by executing an EOI command.
- BIT2** The DATA SAT bit is set by any conversion which is saturated, i.e., any conversion whose output data exceeds positive or negative full scale.
- BIT3** The CMD ERR bit indicates that the most recently loaded command contained a contextual or syntactic error, or was not recognized. It is cleared when the next command is loaded.
- BIT4** The INT bit (also available on Pin 11 of the module) goes high to indicate that the input signal is currently being integrated. It is used in multiplexed systems to determine when the input multiplexer may be switched.
- BIT5** The PWRUP bit (also available on Pin 14 of the module) goes high when the module is powered up or when the RST command is executed. It remains high until device initialization is complete. This signal is used to indicate readiness of the converter after system initialization.

B7	B6	B5	B4	B3	B2	B1	B0
*	*	PWRUP	INT	CMD ERROR	DATA SAT	DATA RDY	BUSY

\* UNUSED: CONTENTS INDETERMINATE

Figure 7. The Status Byte

## OUTPUT DATA FORMAT

The AD1170 architecture allows a programmable data format independent of the integration time. The user may specify any resolution from 7 to 22 bits, and may specify either offset binary coding or two's complement coding. Programming the data format is accomplished via the use of the SDF command, using the format code described in the table in Figure 8 as the PARAMETER 1 value.

C <sub>4</sub>	C <sub>3</sub>	C <sub>2</sub>	C <sub>1</sub>	C <sub>0</sub>	DATA FORMAT
H	X	X	X	X	Two's Complement
L	X	X	X	X	Offset Binary
X	H	H	H	H	22 Bits
X	H	H	H	L	21 Bits
X	H	H	L	H	20 Bits
X	H	H	L	L	19 Bits
X	H	L	H	H	18 Bits
X	H	L	H	L	17 Bits
X	H	L	L	H	16 Bits
X	H	L	L	L	15 Bits
X	L	H	H	H	14 Bits
X	L	H	H	L	13 Bits
X	L	H	L	H	12 Bits
X	L	H	L	L	11 Bits
X	L	L	H	H	10 Bits
X	L	L	H	L	9 Bits
X	L	L	L	H	8 Bits
X	L	L	L	L	7 Bits

X = DON'T CARE (C<sub>7</sub>, C<sub>6</sub>, C<sub>5</sub> = X FOR ALL DATA FORMATS)

Figure 8. Format Code

It should be noted that the AD1170 computes all data to 22 bit resolution. However, not all 22 bits are useable, since the differential performance is largely dependent upon factors such as integration period and calibration period. The SDF command simply serves to round off the result to the specified number of bits. The graph in Figure 4 can be used to estimate the amount of useable resolution achievable for a specified integration period and calibration period.

The output data is always right justified within the three output bytes (LOW DATA, MID DATA, and HIGH DATA). If two's complement format is selected, the MSB of the data is inverted and extended all the way to the top of the HIGH DATA byte. For example, if 16 bit two's complement format is selected, the data will appear in the LOW DATA and MID DATA bytes, and the MSB will be 0 for positive inputs.<sup>2</sup> The format is a nonvolatile parameter; whenever an SAVA command is executed, the current format will be saved to nonvolatile memory, and will become the default format upon powerup.

<sup>1</sup>The minimum duration for EXT CC is one microsecond.

<sup>2</sup>Since the sign is extended all the way to the top of the uppermost byte, the HIGH DATA byte will be filled with the value of the MSB.

**PROGRAMMING THE INTEGRATION PERIOD**

The key parameter of any integrating A/D converter is the integration period. As shown in Figure 9, an integrating A/D converter provides maximum normal mode rejection at those frequencies which are integral multiples of  $1/T(int)$ , where  $T(int)$  is the integration period. The most common way to exploit this characteristic is to set the integration period equal to one period of the power line frequency so that ac hum will be rejected.

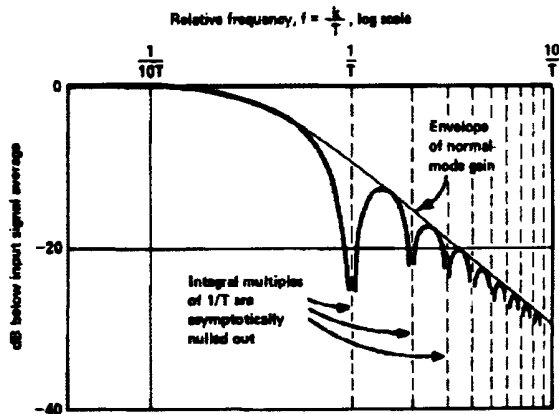

Figure 9. Normal Mode Rejection

The duration of the integration also affects the resulting resolution of the data; long integration times result in more usable resolution than do short integration periods.

The AD1170, unlike most dual slope converters, offers the user the capability of programming the integration time. This feature can be used to great advantage in systems design, since the integration time can be optimized for differing system conditions. For example, in systems whose inputs are severely polluted by 60Hz noise, the user may wish to program the AD1170 for a 100 millisecond integration time, which will result in excellent 60Hz normal mode rejection. In another application, a user may wish to scan a large number of channels rapidly, looking for gross input changes, then slow down in order to make a high resolution conversion before resuming rapid scanning.

The AD1170 offers the user a number of different ways to set the integration period. The simplest way is by using the SDI command to set the default integration period to one of seven preset periods (1ms, 10ms, 16.66ms, 20ms, 100ms, 166.66ms, 300ms). The first two preset periods offer fairly rapid scanning at reduced resolution; the other five represent American and European line voltage standards or multiples thereof. For single conversions without altering the default integration time, the CNVP command may be used, which also allows the selection of one of these seven preset periods. These preset periods and their corresponding codes are listed in the table of Figure 10.

Another way in which the integration period may be programmed is via the EIS command, which allows the user to load the externally definable period register with a binary value<sup>1</sup> proportional to the desired integration period. Using this technique, the user may specify any period from one millisecond to 350 milliseconds (with 200 microsecond accuracy). Access to this user definable period is via the SDI or CNVP commands; the last entry in Figure 10 is used to select the period defined by the EIS or ELS command.

C <sub>2</sub>	C <sub>1</sub>	C <sub>0</sub>	INTEGRATION TIME	NOTES
L	L	L	1 Millisecond	
L	L	H	10 Milliseconds	
L	H	L	16.667 Milliseconds	1 cycle @ 60Hz
L	H	H	20 Milliseconds	1 cycle @ 50Hz
H	L	L	100 Milliseconds	50/60Hz
H	L	H	166.67 Milliseconds	10 cycles @ 60Hz
H	H	L	300 Milliseconds	50/60Hz
H	H	H	(See Note)	

**NOTE**  
This code is used for externally loaded integration times (defined with the EIS Command) or externally measured times (from the ELS Command). The value can be anywhere from 1 Millisecond to 350 Milliseconds.

Figure 10. Preset Integration Periods

The third way to set the integration period is via the external line sampling feature, using the ELS command. This command samples the period of the logic signal presented to the ELS input pin (Pin 12), and sets the externally definable period register accordingly. This feature is most useful in environments with fluctuating line frequencies. By executing an occasional ELS command, the converter effectively "tracks" the line frequency. To use this feature, a clean, bounce free logic representation of the line frequency must be present at the ELS input during the execution of the ELS command. Once having performed the ELS command, the measured integration time may be selected using the SDI or CNVP commands along with the (HHH) code from the table in Figure 10<sup>2</sup>.

It should be noted that the actual integration period used in the measurement process is accurate to about  $\pm 200\mu s$ , due to the limitations of the charge balancing converter. This is adequate, however, for greater than 50dB of normal mode rejection at 60Hz when using an integration period of 1/60 second. Even greater normal mode rejection may be obtained when the integration period is a multiple of the line frequency period.

**CONTROLLING THE CALIBRATION CYCLE**

The AD1170 achieves its excellent span and offset stability by calibrating itself against its internal reference voltages. The user can control the frequency of occurrence for calibration cycles and their duration.

The duration of the calibration cycle is an important parameter, because it affects the accuracy of the calibration cycle itself. Errors in the calibration cycle appear in the output data as instantaneous offset and span errors. If automatic "background" calibration is enabled, these errors effectively appear as noise. Just as in the case of input conversions, longer calibration times result in more accuracy and less noise.

Of course there may be system applications where there simply isn't sufficient time to perform a long calibration cycle. For this reason, the AD1170 offers the user the ability to specify the calibration period, using the SDC command.

The argument for the SDC command is the same three-bit code as is used for the SDI and CNVP commands. The reason for

<sup>1</sup>See the section titled "The AD1170 Command Set" for the formula used to compute the proper binary value.

<sup>2</sup>Caution is advised; if no signal is present at the ELS input when the ELS command is executed, or if the signal is not within acceptable frequency limits, the module may "hang" and require a hardware reset to continue operation.

## AD1170

this is that each calibration cycle consists essentially of two ordinary conversion cycles, performed upon the internal zero and span references. For example, if an SDC command with an argument of 3 is executed, the default calibration time will then be approximately 49 milliseconds (two conversions of 20 milliseconds plus approximately 9 milliseconds for the internal mathematics).

The user may also disable or enable background calibration. In systems where the AD1170 may be periodically idle, i.e., not performing input conversions, background calibration is a good choice. This mode is enabled with the CALEN command and will cause the AD1170 to continually initiate an internal calibration cycle whenever the converter is otherwise unoccupied. Any conversion commands received during a cal cycle will cause that cal cycle to be aborted in favor of the input conversion, thereby giving the user priority over calibration. This mode of operation is automatic and transparent.

The CALDI instruction is used to disable background calibration. When this instruction is executed, the converter will be completely idle between convert commands, and calibration cycles will only occur when invoked by the SCAL command. This mode of operation is best when the user would like to perform input conversions at the maximum rate, and/or when the system affords a specific convenient time to perform calibration.

There are no hard and fast rules about the best way to apply all of this flexibility, but best performance will be obtained if the following points are observed:

- Consult the chart in Figure 4 to determine the minimum effective calibration period for use with a desired integration period.
- Don't use automatic background calibration unless your system will allow the converter enough uninterrupted time to perform at least one calibration cycle. For example, if you are using a calibration period code of 3, your system must periodically allow at least 49 milliseconds without a convert command or calibration will not occur.
- Remember that the purpose of the calibration cycle is to cancel the intrinsic drift of the charge balancing converter within the AD1170 itself. If the converter is in a stable environment, calibration may be done less frequently. The best possible performance will be achieved in stable ambient temperatures, where calibration is manually invoked by the system at relatively long intervals, using the longest allowable calibration time.
- Very short calibration times, although allowed by the AD1170 firmware, are not especially useful because they introduce more error than they compensate. The only useful purpose of very short calibration times is in systems which are operating in rapidly changing ambient temperatures, and then only for relatively low resolution conversions.

### COMPENSATION OF EXTERNAL OFFSETS

An electronic "null" feature compensates for offset errors of signal conditioning stages preceding the AD1170.

The null feature comprises three commands: NULL measures the input signal (using the current integration time) and stores it in internal RAM; NULEN subtracts the measured value from all subsequent conversions; NULDI cancels the NULEN command's effect.

The sum of the offset value plus the full-scale input should be less than the  $\pm 6$  volts linear input range of the AD1170. The

offset value to be nulled should ideally be no more than a few hundred millivolts in amplitude.

The NULL command does not need to be executed every time the AD1170 is powered up. Since the value measured by the NULL command is saved and restored by the SAVA and RESA commands, the value of the null will be the one saved during the last SAVA command. Execute a NULL command only when a new null measurement is desired.

When NULEN is in effect, the length of each conversion will be extended by approximately 700 microseconds.

### ELECTRONIC CALIBRATION

The AD1170 contains an Electronic CALibration capability, which, along with the internal nonvolatile memory chip, effectively eliminates the need for trim potentiometers of any kind. This capability, abbreviated as ECAL, should not be confused with the internal background calibration cycles. ECAL is a completely distinct function used to calibrate the AD1170 to an external reference standard.

The ECAL function measures the ratio of the internal reference voltage in the module with respect to an externally applied reference voltage. The resulting coefficient is applied to the math computations for all subsequent conversions, effectively compensating the module for absolute value errors in its own reference. The ratio is stored in random access memory until the user invokes a SAVA command, which will save this coefficient (along with the other nonvolatile parameters) in the nonvolatile memory chip. When the module is powered up, the previously saved coefficient is recalled from nonvolatile memory and stored in random access memory.

In order to use the ECAL command, the input to the AD1170 must first be presented with an external +5 volt reference standard such as is usually found in many calibration labs. The ECAL command may then be invoked; the external reference voltage must remain at the input until command execution is complete. If the calibration is to be made nonvolatile, a SAVA command must then be invoked.<sup>1</sup>

ECAL may also be used as a means of making limited ratiometric measurements. For example, in some applications, it may be useful to be able to measure the output of some transducer with respect to its excitation; if the excitation can be scaled to the range of 4.5 to 5.5 volts, then it can be used as an excitation for the ECAL process. Having digitized the excitation, all subsequent conversions will be ratioed to the ECAL value. For example, if an ECAL procedure is performed upon a 4.5 volt source, and the converter subsequently digitizes a 2.25 volt signal, the converter output will be half of full scale, or 11000... (assuming offset binary coding). The converter can be restored to absolute calibration by executing a RESA command, which will restore the last nonvolatile ECAL coefficient to random access memory.

The user is cautioned that the nonvolatile memory used in the AD1170 has a finite endurance of 1000 write cycles minimum. Assuming that the AD1170 is calibrated weekly, this implies a device life span of greater than 19 years. Less frequent calibrations mean a proportionately longer life span. This means ECAL may be performed any number of times, but the user should limit the number of SAVA commands in order to extend the life span of the nonvolatile memory.

<sup>1</sup>Since the SAVA command saves all nonvolatile parameters, the user should be sure that the other default parameters, such as integration time and data format, are set to their desired values before SAVA is invoked.



**NONVOLATILE MEMORY**

The internal nonvolatile memory in the AD1170 is used to store the various nonvolatile parameters associated with A/D operation (for example, the integration period, data format, ECAL coefficient, etc.).

In addition, eight 16-bit words of the nonvolatile memory are made available to the user for general purpose use. They may be accessed using the RDNV and WRNV commands. Because the nonvolatile memory is specified for a finite endurance of 1000 write cycles minimum, it is best used for data which does not regularly need to change, such as configuration information or system calibration parameters.

**FACTORY DEFAULT SETTINGS**

The AD1170 is calibrated at the factory; the factory default settings are:

- Format: 16-bit, offset binary
- Default T(int): 16.667 milliseconds (code 2)
- Default T(cal): 100 milliseconds (code 4)

**THE AD1170 COMMAND SET**

The AD1170 command code set includes 20 different functions. Some of the commands require no parameters, while others require one or two parameters which must be loaded into the PARAMETER 1 and PARAMETER 2 registers prior to loading the command register. Some commands (for example, CNVP) have their option parameter embedded in the lowest three bits of the command itself.

The execution time for any command depends on the command. Figure 11 is a synopsis of the available commands, as well as estimates of their execution times.

Each of the commands described below is preceded by an opcode name, along with the digital code (in binary).

**CALEN** 10110000

CALEN (CALibration ENable) enables automatic background calibration cycling. In this mode, background calibration cycles are executed automatically whenever the AD1170 is not otherwise occupied. If a command is received during a calibration cycle, that cycle will be aborted and the command will be executed.

**CALDI** 10111000

CALDI (CALibration DIisable) disables automatic background calibration. After executing this command, the AD1170 will be completely idle between commands. While in this state, a single calibration cycle may be invoked with the SCAL command.

**CNV** 00001000

CNV (CoNVert) causes a single conversion to be performed, using the current default integration time and data format.

**CNVP** 00010C<sub>2</sub>C<sub>1</sub>C<sub>0</sub>

CNVP (CoNVert using specific Preset time) causes a single conversion to be performed, using one of the eight preset integration times as listed in Figure 10. The default integration time is not changed. The three bit code for the desired integration time is embedded in the lowest three bits of the command code.

**ECAL** 00011000

ECAL (Electronic CALibration) causes an electronic calibration cycle to be performed. An external +5 volt reference voltage must be presented to the input before this command is executed, and the input must remain stable until the end of command execution is signaled by the BUSY line or the BUSY bit in the status word. The calibration data computed by this command is applied to all subsequent conversions, but is not made nonvolatile until a SAVA command is performed.

MNEMONIC	FUNCTIONAL DESCRIPTION	EXECUTION TIME (APPROX)
CNV	Perform a Single Conversion Using the Default Integration Time	T(int) + 3ms
CNVP	Perform a Single Conversion Using the Specified Integration Time	T(int) + 3ms
ELS	Measure Period of Signal at the ELS Input	2 × T(int) + 20ms
ECAL	Perform Electronic CALibration Routine	1.5 seconds
SDI	Set Default Integration Time for Input Measurements	150μs
SDC	Set Default Calibration Period	160μs
SDF	Set Default Data Format	140μs
RESA	Restore All Nonvolatile Parameters from Memory	2.3ms
SAVA	Save All Nonvolatile Parameters to Memory	150ms
WRNV	Write a Word to the User EEPROM Area	22ms
RDNV	Read a Word from the User EEPROM Area	600μs
EOI	Clear the Data Ready Flag	260μs
SCAL	Perform a Single Cal Cycle	2 × T(cal) + 9ms
CALEN	Enable Background Calibration	300μs
CALDI	Disable Background Calibration	310μs
EIS	Set Integration Time to Arbitrary Value	130μs
RST	Reset AD1170 to Power Up Conditions	210ms
NULL	Measure the Offset Voltage Value at the AD1170 Input and Store	T(int) + 3ms
NULEN	Subtract NULL Measured Value from All Subsequent Conversions	250μs
NULDI	Cancel the Effect of the NULEN Command	250μs

Figure 11. Synopsis of Commands

# AD1170

**EOI** 10001000  
**EOI** (End Of Interrupt) clears the DTA RDY bit in the status byte, as well as the DTA RDY line (Pin 10). It is provided as a means of clearing the interrupt source in systems which use an interrupt upon data ready.

**ELS** 00100000  
**ELS** (External Line Sample) measures the period of the logic signal applied to the ELS input (Pin 12)<sup>1</sup>. This period is loaded into the register associated with the last entry of the table in Figure 10. Input conversions using this measurement as the integration period may be performed by invoking a CNVP command, or by setting the default integration period with the SDI command. This command is intended for use in environments with varying line power frequency; periodically invoking this command allows effective tracking for improved normal mode rejection.

**EIS** 00101000  
**EIS** (External Integration Set) is used to establish an arbitrary integration period from 1 millisecond to 350 milliseconds. To use this command, first load the PARAMETER 1 and PARAMETER 2 registers with the 16-bit binary number N, which is calculated using the following expression:

$$N = 2^{16} - T(\text{int})/21.333\text{E-}6$$

After the low and high bytes representing N are loaded into the PARAMETER 1 and PARAMETER 2 registers respectively, execute the EIS command. Once this command is executed, the externally loaded integration time can be used via the CNVP or SDI commands.

**RESA** 01101000  
**RESA** (REStore All) restores all configuration parameters (default integration time, default calibration time, data format, EIS/ELS period, NULL value and electronic calibration data) from non-volatile memory. After executing this function, all parameters will be restored to their last value as saved by the SAVA command.

**SAVA** 01001000  
**SAVA** (SAVe All) saves all programmable attributes (default integration time, default calibration time, data format, EIS/ELS period, NULL value and electronic calibration data) into non-volatile memory.

**SDI** 00111C<sub>2</sub>C<sub>1</sub>C<sub>0</sub>  
**SDI** (Set Default Integration time) sets the default integration time to one of the eight preset times listed in Figure 10. The three-bit code for the desired integration time is embedded in the lowest three bits of the command code.

**SDF** 00110000  
**SDF** (Set Default Format) sets the default data format according to the five bit code loaded into the PARAMETER 1 register prior to execution of this command. The table in Figure 8 illustrates the construction of the five bit code according to the desired data format and resolution.

**SCAL** 11000000  
**SCAL** (Single CALibration) performs a single background calibration cycle. This command is intended for use when automatic background calibration has been disabled via the CALDI command.

**SDC** 01000C<sub>2</sub>C<sub>1</sub>C<sub>0</sub>  
**SDC** (Set Default Calibration time) sets the default calibration time (Tcal) according to the three bit code embedded in the lowest three bits of the command. The calibration times are shown in Figure 10. Note that the actual duration of a calibration cycle is approximately  $2 \times T(\text{cal}) + 9$  milliseconds.

**WRNV** 10011A<sub>2</sub>A<sub>1</sub>A<sub>0</sub>  
**WRNV** (WRite NonVolatile) writes the user supplied data, in the PARAMETER 1 and PARAMETER 2 registers, into the user accessible area of the AD1170's nonvolatile memory. Eight words of this memory are available, and are addressed by the lowest three bits of the command.

**RDNV** 10100A<sub>2</sub>A<sub>1</sub>A<sub>0</sub>  
**RDNV** (ReaD NonVolatile) reads one word from the user accessible portion of the nonvolatile memory within the AD1170, and places the data into the LOW DATA and MID DATA registers for retrieval by the user. The address of the desired word is embedded into the lowest three bits of the command.

**RST** 10010000  
**RST** (ReSeT) is effectively equivalent to a hardware reset of the AD1170. After executing this command, all nonvolatile parameters (including the ECAL coefficient, the default integration and calibration periods, EIS/ELS period, NULL value and the default format) will be restored to their last saved values, automatic calibration will be enabled, and NULL will be disabled.

**NULL** 01110000  
**NULL** measures the input signal (using the current integration time value) and stores the measurement in internal RAM. It allows the user to establish the value of offset voltage at the input and subtract that offset from subsequent conversions through the execution of the NULEN command. The user must insure that the sum of the offset value plus the full scale input is less than the  $\pm 6$  volts linear input range of the AD1170. Ideally the offset value to be nulled should be no more than a few hundred millivolts in amplitude. The value measured by the NULL command is saved and restored by the SAVA and RESA commands - maintaining this value through subsequent powerups. The NULL command need only be invoked when a new null measurement is desired.

**NULEN** 01111000  
**NULEN** (NULI ENable) subtracts the value, measured and stored by the last NULL command, from all subsequent conversions. When NULEN is in effect, each conversion's length will be extended by approximately 700 microseconds.

**NULDI** 10000000  
**NULDI** (NULI DIisable) cancels the effect of the NULEN command.

<sup>1</sup>This logic signal should be a TTL or CMOS compatible continuous waveform. It need not be symmetrical, but the HIGH or LOW time should not be less than 25 microseconds.

## Applying the AD1170

### IBM PC INTERFACE

Figure 12 is an example of an AD1170/IBM interface suitable for the IBM PC or XT personal computers. In this case, the AD1170 is interfaced in the I/O space; the DIP switch controls the specific location of the AD1170 within the available address space.

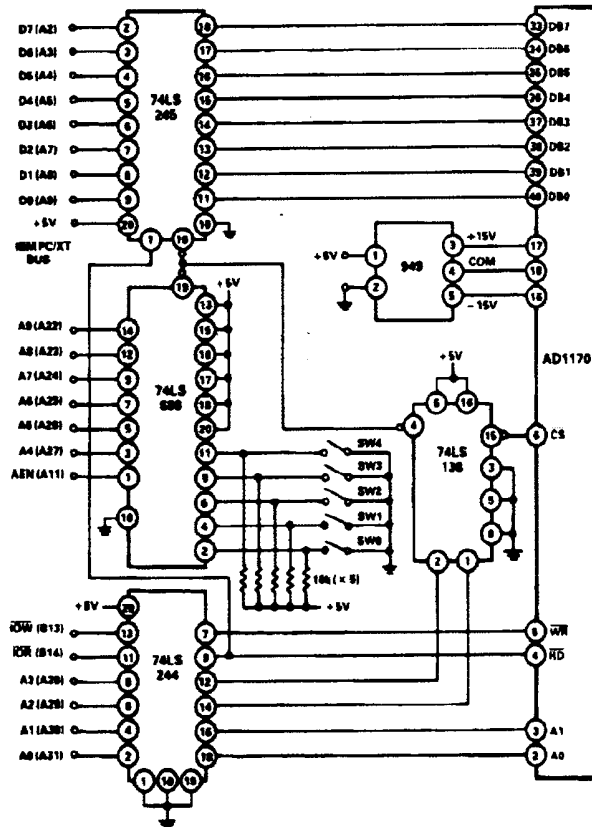

Figure 12. IBM PC/XT to AD1170 Interface

### INTERFACING TO AN 8051 MICROCONTROLLER

Figure 13 shows how an AD1170 may be interfaced to an 8051 microcontroller using a technique commonly called "byte banging", where the control lines and data bus of a device are manipulated under firmware control. This "byte banging" technique can be adapted to most microprocessors and is useful in situations where a conventional bus structure is either nonexistent or unavailable for use.<sup>1</sup>

The AD1170's data bus is connected to the 8051 using I/O lines P2.0 through P2.7. The address lines A0 and A1 are connected to I/O lines P1.0 and P1.1 respectively. The RD/ and WR/ lines are connected to P1.2 and P1.3. The CS/ line of the AD1170 is grounded when it is the only device connected to the 8051, but multiple AD1170s could easily be connected in the same way if each CS/ line were separately controlled.

<sup>1</sup>Note that the 8051 microcontroller *does* contain a conventional bus structure; the "byte banging" interface shown here is presented as an example of an alternative technique.

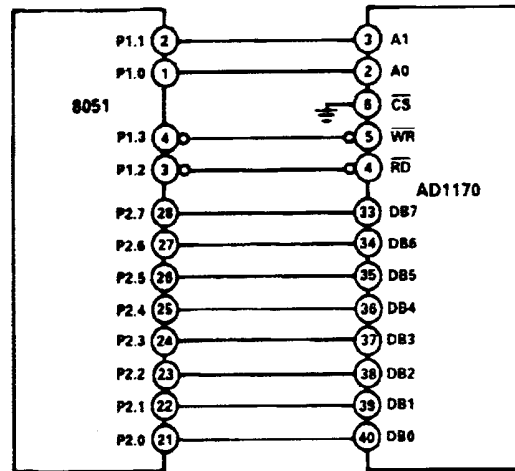

Figure 13. Simple 8051 to AD1170 Interface

To initialize the interface, first write "1"s to the port pins connected to the data bus and the RD/ and WR/ control lines. This puts the 8051 I/O lines into a lightly "pulled up" state, simulating a tri-stated condition on the bus to insure that neither RD/ or WR/ are selected:

```
INIT:  SETB  P1.2      ;DISABLE RD/
        SETB  P1.3      ;AND WR/
        ;
        MOV  P2, #OFFH ;SET P2 TO ALL ONES
```

To write a command to the AD1170, first set the state of the P1.1 and P1.0 lines for the address corresponding to the byte to be written to. Set the P2 port to the command data, then strobe the WR/ line by first clearing the P1.3 line and then setting it:

```
WRCMD: CLR  P1.0      ;FIRST CLEAR A0 AND A1
        CLR  P1.1      ;TO POINT TO CMD BYTE
        ;
        MOV  P2, #CNV  ;CNV IS THE OPCODE FOR
        ;              ;A SINGLE CONVERSION
        ;
        CLR  P1.3      ;STROBE THE WR/ LINE
        SETB P1.3      ;ONE TIME
        ;
        MOV  P2, #OFFH ;CLEAR DATA BUS TO
        ;              ;ALL ONES
```

To read a byte from the AD1170, first set the P1.0 and P1.1 lines to point to the address of the byte desired. Bring the RD/ line low, reading the contents of P2. Return the RD/ line high:

```
RDSTAT: CLR  P1.0      ;POINT TO STATUS BYTE
        CLR  P1.1      ;
        ;
        CLR  P1.2      ;BRING RD/ LINE LOW
        MOV  A, P2     ;READ CONTENTS OF BUS
        SETB P1.2     ;RESTORE RD/ LINE HIGH
```

## AD1170

### PRESSURE TRANSDUCER DATA ACQUISITION

A two module solution for microcomputer based data acquisition uses a 1B31 hybrid signal conditioner and an AD1170 as shown in Figure 14. A 3 millivolt/volt pressure transducer (c.g., Dynisco's 800 series) is interfaced to a model 1B31 configured for a gain of 333.3, to provide a 0 to 5 volt output. The regulated excitation voltage is 5 volts, and is used as the reference input for the AD1170 to produce ratiometric operation. This configuration yields very high CMR enhanced by the 1B31 low pass filter and the integrating conversion scheme of the AD1170.

In addition, fixed offsets caused by bridge imbalance can be nulled out by the AD1170 with a power-up initialization command from the microcomputer (see COMPENSATION OF EXTERNAL OFFSETS section). The full-scale output of the 1B31 and Transducer can also be normalized to AD1170 full scale through the electronic calibration command ECAL. Both the offset and full-scale correction data can then be stored in nonvolatile memory to eliminate repeating this trim process after each power-up. The AD1170 eliminates a potentiometer or software overhead which might otherwise be needed for these functions.

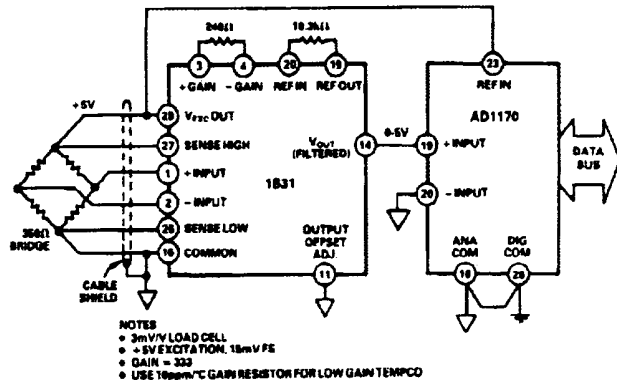

Figure 14. Pressure Transducer Data Acquisition Using 1B31 and AD1170

## AC5004

### . . . an IBM PC/XT/AT Compatible Evaluation Board for the AD1170

#### FEATURES

- Compatible to the IBM PC/XT/AT or Equivalent
- Menu-Driven Demonstration Software
- Input Mating Connector
- Full Documentation
- Example Listings of BASIC Programs
- Schematic
- Assembly Drawing
- Complete Set of Tools to Evaluate an AD1170
- A/D Converter

#### GENERAL DESCRIPTION

The AC5004 was designed as a support tool to enable the user to easily and quickly evaluate Analog Devices' AD1170 high-resolution programmable integrating A/D converter. The AD1170 is inserted directly into an AC5004 board which is designed to plug into the backplane of an IBM PC/XT/AT. Thus, armed with an IBM PC, an AD1170, and an AC5004 evaluation board, the user is fully prepared to examine the operation of the AD1170.

A User's Manual provides all the information required to put the AC5004/AD1170 evaluation process into operation. In the manual are full descriptions of the AC5004 memory address and power source selection jumpers as well as a schematic documenting the interface of the AD1170 to a computer bus.

The package also contains a comprehensive demonstration program written in BASIC that completely exercises all the functions of the AD1170. The AC5004 is an accessory that will make readily available to the user all the tools needed to comprehensively test the AD1170.

#### PRODUCT HIGHLIGHTS

- AC5004 plugs directly into IBM PC/XT/AT or compatibles. Standard short slot card size (5 7/8" × 5" × 1").
- The AC5004 enables the user to evaluate the AD1170 high-resolution, programmable, integrating A/D converter without having to build a bread-board or prototype.
- The evaluation boards come complete with software and programming examples designed to exercise all of the AD1170's functions.
- AC5004 schematic and assembly drawings are provided to be used as examples of how to interface the AD1170 to a microprocessor bus.

#### Please note:

Order AC5004 (does not include AD1170).