

## General Description

The VDS6632A4A are four-bank Synchronous DRAMs organized as 524,288 words x 32 bits x 4 banks,

Synchronous design allows precise cycle control with the use of system clock I/O transactions are possible on every clock cycle.

Range of operating frequencies, programmable burst length and programmable latencies allow the same device to be useful for a variety of high bandwidth high performance memory system applications

## Features

- JEDEC standard LVTTTL 3.3V power supply
- MRS Cycle with address key programs
  - CAS Latency (2 & 3)
  - Burst Length (1,2,3,8,& full page)
  - Burst Type (sequential & Interleave)
- 4 banks operation
- All inputs are sampled at the positive edge of the system clock
- Burst Read single write operation
- Auto & Self refresh
- 4096 refresh cycle
- DQM for masking
- Package:86-pins 400 mil TSOP-Type II

## Ordering Information.

Part No.	Frequency	Interface	Package
VDS6632A4A-5	200Mhz	LVTTTL	400mil 86pin TSOPII
VDS6632A4A-5.5	183Mhz	LVTTTL	400mil 86pin TSOPII
VDS6632A4A-6	166Mhz	LVTTTL	400mil 86pin TSOPII

## Pin Assignment

VDD	1	86	VSS
DQ0	2	85	DQ15
VDDQ	3	84	VSSQ
DQ1	4	83	DQ14
DQ2	5	82	DQ13
VSSQ	6	81	VDDQ
DQ3	7	80	DQ12
DQ4	8	79	DQ11
VDDQ	9	78	VSSQ
DQ5	10	77	DQ10
DQ6	11	76	DQ9
VSSQ	12	75	VDDQ
DQ7	13	74	DQ8
NC	14	73	NC
VDD	15	72	VSS
DQM0	16	71	DQM1
WE	17	70	NC
CAS	18	69	NC
RAS	19	68	CLK
CS	20	67	CKE
NC	21	66	A9
BA0	22	65	A8
BA1	23	64	A7
A10/AP	24	63	A6
A0	25	62	A5
A1	26	61	A4
A2	27	60	A3
DQM2	28	59	DQM3
VDD	29	58	VSS
NC	30	57	NC
DQ16	31	56	DQ31
VSSQ	32	55	VDDQ
DQ17	33	54	DQ30
DQ18	34	53	DQ29
VDDQ	35	52	VSSQ
DQ19	36	51	DQ28
DQ20	37	50	DQ27
VSSQ	38	49	VDDQ
DQ21	39	48	DQ26
DQ22	40	47	DQ25
VDDQ	41	46	VSSQ
DQ23	42	45	DQ24
VDD	43	44	VSS

86-pin plastic TSOP II 400mil

## Pin Description

PIN	NAME	FUNCTION
CLK	System Clock	Active on the positive edge to sample all inputs.
CKE	Clock Enable	Masks system clock to freeze operation from the next clock cycle. CKE should be enabled at least on cycle prior new command. Disable input buffers for power down in standby
/CS	Chip Select	Disables or Enables device operation by masking or enabling all input except CLK, CKE and DQM0 ~ DQM3
A0~A11	Address	Row / Column address are multiplexed on the same pins. Row address : RA0~RA10 Column address : CA0~CA7
BA0~BA1	Banks Select	Selects bank to be activated during row address latch time. Selects bank for read / write during column address latch time.
DQ0~DQ31	Data	Data inputs / outputs are multiplexed on the same pins.
DQM0~3	Data Mask	Makes data output Hi-Z,
/RAS	Row Address Strobe	Latches row addresses on the positive edge of the CLK with /RAS low
/CAS	Column Address Strobe	Latches Column addresses on the positive edge of the CLK with /CAS low
/WE	Write Enable	Enables write operation and row recharge.
VDD/VSS	Power Supply/Ground	Power and Ground for the input buffers and the core logic.
VDDQ/VSSQ	Data Output Power/Ground	Power supply for output buffers.
NC	No Connection	This pin is recommended to be left No Connection on the device.

## Block Diagram

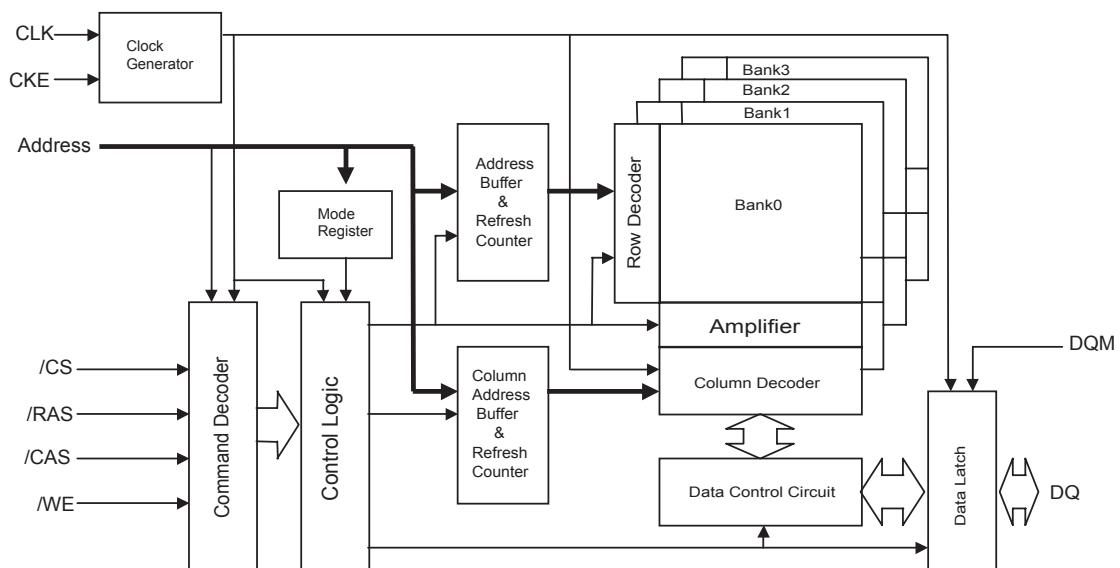

### Absolute Maximum Ratings

Parameter	Symbol	Value	Unit
Voltage on any pin relative to Vss	V <sub>IN</sub> , V <sub>out</sub>	-1.0 ~ 4.6	V
Voltage on VDD supply relative to Vss	V <sub>DD</sub> , V <sub>DDQ</sub>	-1.0 ~ 4.6	V
Storage temperature	T <sub>STG</sub>	-55 ~ +150	°C
Power dissipation	P <sub>D</sub>	1	W
Short circuit current	I <sub>os</sub>	50	mA

**Note** : Permanent device damage may occur if ABSOLUTE MAXIMUM RATING are exceeded.

Functional operation should be restricted to recommended operating condition.

Exposure to higher than recommended voltage for extended periods of time could affect device reliability.

### DC Operating Condition

Voltage referenced to Vss = 0V, T<sub>A</sub> = 0 to 70 °C

Parameter	Symbol	Min	Typ	Max	Unit	Note
Supply voltage	V <sub>DD</sub> , V <sub>DDQ</sub>	3.0	3.3	3.6	V	
Input logic high voltage	V <sub>IH</sub>	2.0	3.0	V <sub>DD</sub> +0.3	V	1
Input logic low voltage	V <sub>IL</sub>	-0.3	0	0.8	V	2
Output logic high voltage	V <sub>OH</sub>	2.4	-	-	V	I <sub>OH</sub> =-2mA
Output logic low voltage	V <sub>OL</sub>	-	-	0.4	V	I <sub>OL</sub> =2mA
Input leakage current	I <sub>IL</sub>	-5	-	5	uA	3
Output leakage current	I <sub>OL</sub>	-5	-	5	uA	4

**Note** : 1. V<sub>IH</sub> (max)=4.6V AC for pulse width ≤ 10ns acceptable.

2. V<sub>IL</sub>(min)=-1.5V AC for pulse width ≤ 10ns acceptable.

3. Any input 0V ≤ V<sub>IN</sub> ≤ V<sub>DD</sub> + 0.3V, all other pins are not under test = 0V.

4. Dout is disabled, 0V ≤ V<sub>OUT</sub> ≤ V<sub>DD</sub>.

### AC Operating Condition

Voltage referenced to Vss = 0V, T<sub>A</sub> = 0 to 70 °C

Parameter	Symbol	Value	Unit	Note
AC input high / low level voltage	V <sub>IH</sub> / V <sub>IL</sub>	2.4 / 0.4	V	
Input timing measurement reference level voltage	V <sub>trip</sub>	1.4	V	
Input rise / fall time	T <sub>R</sub> / t <sub>F</sub>	1	Ns	
Output timing measurement reference level	V <sub>outf</sub>	1.4	V	
Output load capacitance for access time measurement	C <sub>L</sub>	30	pF	2

**Note**: 1. 3.15V ≤ V<sub>DD</sub> ≤ 3.6V is applied for VDS6632A4A5.

2. Output load to measure access times is equivalent to two TTL gates and one capacitor (30pF). For details, refer to AC/DC output load circuit.

### Capacitance

TA=25°C, f=1Mhz, VDD=3.3V

Parameter	Pin	Symbol	Min	Max	Unit
Input capacitance	CLK	CI1	2.5	4	pF
	A0~A11,BA0,BA1,CKE,/CS,/RAS, /CAS,/WE,DQM	CI2	2.5	5	pF
Data input / output capacitance	DQM	CI/O	4	6.5	pF

### Output load circuit

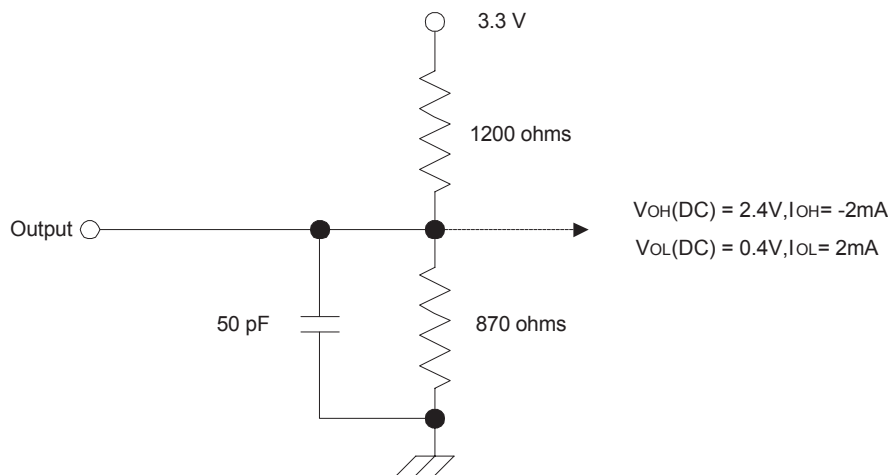

### DC Characteristics I

Parameter	Symbol	Min	Max	Unit	Note
Input leakage current	$I_{LI}$	-1	1	$\mu A$	1
Output leakage current	$I_{LO}$	-1.5	1.5	$\mu A$	2
Output high voltage	$V_{OH}$	2.4	-	V	$I_{OH} = -2mA$
Output low voltage	$V_{OL}$	-	0.4	V	$I_{OL} = 2mA$

**Note** : 1.  $V_{IN} = 0$  TO 3.6V, All other pins are not tested under  $V_{IN} = 0V$ .

2. DOUT is disabled,  $V_{OUT} = 0$  to 3.6.

## DC Characteristics II

Parameter	Symbol	Test condition	Speed			Unit	Note
			-5	-5.5	-6		
Operating Current	IDD1	Burst length=1, One bank active $t_{RC} \geq t_{RC}(\min)$ , $I_{OL}=0\text{mA}$	210	200	190	mA	1
Precharge standby current in power down mode	IDD2P	$CKE \leq V_{IL}(\max)$ , $t_{CK}=\min$	2			mA	
	IDD2PS	$CKE \leq V_{IL}(\max)$ , $t_{CK}=\infty$	2				
Precharge standby current in Non power down mode	IDD2N	$CKE \geq V_{IH}(\min)$ , $/CS \geq V_{IH}(\min)$ , $t_{CK}=\min$ input signals are changed one time during 2clks. All other pins $\geq V_{DD}-0.2\text{V}$ or $\leq 0.2\text{V}$	15			mA	
	IDD2NS	$CKE \geq V_{IH}(\min)$ , $t_{CK}=\infty$ Input signals are stable.	12				
Active standby current in power down mode	IDD3P	$CKE \leq V_{IL}(\max)$ , $t_{CK}=\min$	6			mA	
	IDD3PS	$CKE \leq V_{IL}(\max)$ , $t_{CK}=\infty$	5				
Active standby current in Non power down mode	IDD3N	$CKE \geq V_{IH}(\min)$ , $/CS \geq V_{IH}(\min)$ , $t_{CK}=\min$ input signals are changed one time during 2clks. All other pins $\geq V_{DD}-0.2\text{V}$ or $\leq 0.2\text{V}$	30			mA	
	IDD3NS	$CKE \geq V_{IH}(\min)$ , $t_{CK}=\infty$ Input signals are stable.	20				
Burst mode operating current	IDD4	$t_{CK} \geq t_{CK}(\min)$ , $I_{OL}=0\text{mA}$ All banks active	280	270	260	mA	1
Auto refresh current	IDD5	$t_{RRC} \geq t_{RRC}(\min)$ , All banks active	250	240	230	mA	2
Self refresh current	IDD6	$CKE \leq 0.2\text{V}$	1			mA	

**Note:** 1. IDD1 and IDD4 depend on output loading and cycle rates. Specified values are measured with the output open.

2. Min. of  $t_{RRC}$  is shown at AC characteristics.

### AC Characteristics

Parameter		Symbol	-5		-5.5		-6		Unit	Note
			Min	Max	Min	Max	Min	Max		
System clock Cycle time	/CAS Latency = 3	tCK3	5	1000	5.5	1000	6	1000	ns	
	/CAS Latency = 2	tCK2	10		10		10			
Clock high pulse width		tCHW	2	-	2.25	-	2.5	-	ns	1
Clock low pulse width		tCLW	2	-	2.25	-	2.5	-	ns	1
Access time form clock	/CAS Latency = 3	tAC3	-	4.5	-	5	-	5.5	ns	2
	/CAS Latency = 2	tAC2	-	6	-	6	-	6		
/RAS cycle time	Operation	tRC	55	-	55	-	60	-	ns	
	Auto Refresh	tRRC	55	-	55	-	60	-		
/RAS to /CAS delay		tRCD	15	-	16.5	-	18	-	ns	
/RAS active time		tRAS	40	100K	38.5	100K	42	100K	ns	
/RAS precharge time		tRP	15	-	16.5	-	18	-	ns	
/RAS to /RAS bank active delay		tRRD	10	-	11	-	12	-	ns	
/CAS to /CAS delay		tCCD	1	-	1	-	1	-	CLK	
Write command to data – in delay		tWTL	0	-	0	-	0	-	CLK	
Data – in to precharge command		tDPL	1	-	1	-	1	-	CLK	
Data – in active command		tDAL	5	-	5	-	5	-	CLK	
DQM to data – out Hi-Z		tDQZ	2	-	2	-	2	-	CLK	
DQM to data – in mask		tDQM	0	-	0	-	0	-	CLK	
Data – out hold time		tOH	1.5	-	2	-	2	-	ns	
Data – input setup time		tDS	1.5	-	1.5	-	1.5	-	ns	1
Data – input hold time		tDH	1	-	1	-	1	-	ns	1
Address setup time		tAS	1.5	-	1.5	-	1.5	-	ns	1
Address hold time		tAH	1	-	1	-	1	-	ns	1
CKE setup time		tCKS	1.5	-	1.5	-	1.5	-	ns	1
CKE hold time		tCKH	1	-	1	-	1	-	ns	1
Command setup time		tCS	1.5	-	1.5	-	1.5	-	ns	1
Command hold time		tCH	1	-	1	-	1	-	ns	1
CLK to data output in low Z-time		tOLZ	1	-	1	-	1	-	ns	
MRS to new command		tMRD	2	-	2	-	2	-	CLK	
Power down exit time		tPDE	1	-	1	-	1	-	CLK	
Self refresh exit time		tSRE	1	-	1	-	1	-	CLK	3
Refresh time		tREF	-	64	-	64	-	64	ms	

**Note** : 1. Assume tR / tF (input rise and fall time) is 1 ns.

2. Access times to be measured with input signals of 1v / ns edge rate.

3.A new command can be given tRRC after self refresh exit.

## Command Truth-Table

Command	CKEn-1	CKEn	/CS	/RAS	/CAS	/WE	DQM	ADDR	A10/AP	BA
Mode Register Set	H	X	L	L	L	L	X	OP code		
No Operation	H	X	H	X	X	X	X	X		
			L	H	H	H				
Bank Active	H	X	L	L	H	H	X	RA		V
Read	H	X	L	H	L	H	X	CA	L	V
Read with Auto Precharge									H	
Write	H	X	L	H	L	L	X	CA	L	V
Write with Auto Precharge									H	
Precharge All Bank	H	X	L	L	H	L	X	X	H	X
Precharge select Bank									L	V
Burst Stop	H	X	L	H	H	L	X	X		
DQM	H	X					V	X		
Auto Refresh	H	H	L	L	L	H	X	X		
Self Refresh	Entry	H	L	L	L	L	H	X	X	
	Exit	L	H	H	X	X	X	X		
L				H	H	H				
Precharge	Entry	H	L	H	X	X	X	X	X	
				L	H	H	H			
Power down	Exit	L	H	H	X	X	X	X		
				L	H	H	H			
Clock Suspend	Entry	H	L	H	X	X	X	X	X	
				L	V	V	V			
	Exit	L	H	X				X		

## Package Information

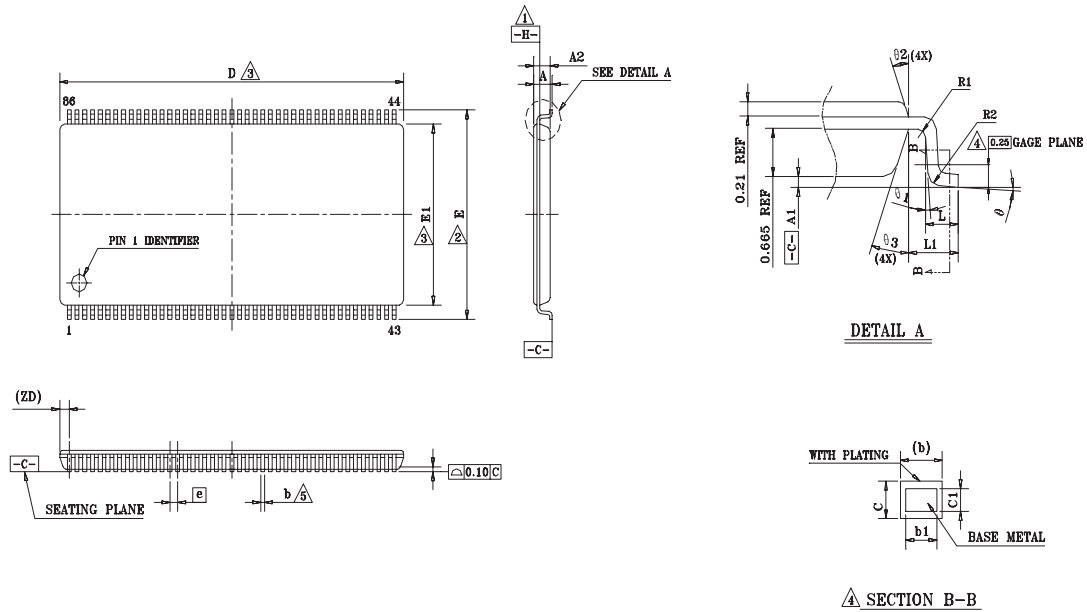

SECTION B-B

Symbol	Dimension in mm			Dimension in inch		
	Min	Norm	Max	Min	Norm	Max
A	—	—	1.20	—	—	0.047
A1	0.05	0.10	0.15	0.002	0.004	0.006
A2	0.95	1.00	1.05	0.037	0.039	0.011
b	0.17	—	0.27	0.007	—	0.018
b1	0.17	0.20	0.23	0.007	0.008	0.009
c	0.12	—	0.21	0.005	—	0.008
c1	0.10	0.127	0.16	0.004	0.005	0.006
D	22.22 BSC			0.875 BSC		
ZD	0.61 REF			0.024 REF		
E	11.76 BSC			0.463 BSC		
E1	10.16 BSC			0.400 BSC		
L	0.40	0.50	0.60	0.016	0.020	0.024
L1	0.80 REF			0.031 REF		
e	0.50 BSC			0.020 BSC		
R1	0.12	—	—	0.005	—	—
R2	0.12	—	0.25	0.005	—	0.010
	0	—	8	0	—	8
1	0	—	—	0	—	—
2	10	15	20	10	15	20
3	10	15	20	10	15	20

400mil 86pin TSOP II Package