

FEATURES

- ± 20 mV ($\pm 0.8\%$) max. initial tolerance (A grade)
- Operating Current 20 μ A to 20mA
- Low Voltage Reference 2.5V
- Max. 0.6 Ω Dynamic Impedance (A grade)
- Low Temperature Coefficient
- 1.2V Device and Adjustable Device also available
AMS285-1.2 and AMS285 series, respectively
AMS385-1.2 and AMS385 series.

APPLICATIONS

- Battery Powered Systems
- Instrumentation
- A/D, D/A Converters
- Temperature measurement
- Current sources
- Notebook/Personal Computer
- Monitors/ VCR/ TV
- Pagers

GENERAL DESCRIPTION

The AMS285-2.5/AMS385-2.5 are two-terminal micropower band-gap voltage reference diodes. They feature a very low dynamic impedance and good temperature coefficient, operating over a 20 μ A to 20mA current range. On-chip trimming is used to provide tight voltage tolerance. Since the AMS285-2.5/AMS385-2.5 is a band-gap reference, uses only transistors and resistors, low noise and good long term stability result. Careful design of the AMS285-2.5/AMS385-2.5 has made the device exceptionally tolerant of capacitive loading, making it easy to use in almost any reference application. The wide dynamic operating range allows its use with widely varying supplies with excellent regulation. The extremely low power drain of the AMS285-2.5/AMS385-2.5 makes these reference diodes useful for micropower circuitry. These voltage references can be used to make portable meters, regulators or general purpose analog circuitry with battery life approaching shelf life. Further more, the wide operating current allows it to replace older references with a tight tolerance part.

The AMS285-2.5 is operational in the full industrial temperature range of -40°C to 85°C while AMS385-2.5 is operating over a 0°C to 70°C temperature range. The AMS285-2.5/AMS385-2.5 are available in TO-92, SO-8 and SOT-89 packages.

ORDERING INFORMATION:

TOL.	PACKAGE TYPE			OPERATING TEMPERATURE RANGE
	TO-92	8 LEAD SOIC	SOT-89	
± 20 mV	AMS285-2.5AN	AMS285-2.5AS	AMS285-2.5AL	-40 to 85° C
± 38 mV	AMS285-2.5BN	AMS285-2.5BS	AMS285-2.5BL	-40 to 85° C
± 75 mV	AMS285-2.5CN	AMS285-2.5CS	AMS285-2.5CL	-40 to 85° C
± 20 mV	AMS385-2.5AN	AMS385-2.5AS	AMS385-2.5AL	0 to 70° C
± 38 mV	AMS385-2.5BN	AMS385-2.5BS	AMS385-2.5BL	0 to 70° C
± 75 mV	AMS385-2.5CN	AMS385-2.5CS	AMS385-2.5CL	0 to 70° C

AMS285-2.5/AMS385-2.5

ABSOLUTE MAXIMUM RATINGS

Reverse Current	30mA	Storage temperature	-55°C to +150°C
Forward Current	10mA	Soldering information	
Operating Temperature Range		TO-92 package: 10 sec.	260°C
AMS285-2.5	-40°C to 85°C	SOIC package: Vapor phase (60 sec)	215°C
AMS385-2.5	0°C to 70°C	Infrared (15 sec.)	220°C
		SOT-89 package: 10 sec.	265°C

ELECTRICAL CHARACTERISTICS

Electrical Characteristics at $I_R = 100 \mu A$, and $T_A = +25^\circ C$ unless otherwise specified.

Parameter	Conditions	AMS285A-2.5			AMS285B-2.5			AMS285C-2.5			Units
		Min	Typ	Max	Min	Typ	Max	Min	Typ	Max	
Reverse Breakdown Voltage (Note 4)	$I_R - 100 \mu A$	2.480	2.500	2.520	2.462	2.500	2.538	2.425	2.500	2.575	V
Reverse Dynamic Impedance (Note 4)	$I_R - 100 \mu A, f = 20Hz$		0.2	0.60		1			1		Ω
Reverse Breakdown Voltage Change with current (Note 4)	$10\mu A \leq I_R \leq 1mA$ $1mA \leq I_R \leq 20mA$		1.0 10				1.0 10			2.0 20	mV
Min. Operating Current (Note 4)			12	18 20		13	20 30		13	20 30	μA μA
Wide Band Noise (Note 5)	$I_R - 100 \mu A,$ $10Hz \leq f \leq 10kHz$		120			120			120		μV
Temperature Coeff. (Note 6)			25			50			100	150	ppm/°C
Long Term Stability (Note 5)	$T_A = 25^\circ C \pm 1^\circ C$ $T = 1000 Hr$		20			20			20		ppm

ELECTRICAL CHARACTERISTICS

Electrical Characteristics at $I_R = 100 \mu A$, and $T_A = +25^\circ C$ unless otherwise specified.

Parameter	Conditions	AMS385A-2.5			AMS385B-2.5			AMS385C-2.5			Units
		Min	Typ	Max	Min	Typ	Max	Min	Typ	Max	
Reverse Breakdown Voltage (Note 4)	$I_R - 100 \mu A$	2.480	2.500	2.520	2.462	2.500	2.538	2.425	2.500	2.575	V
Reverse Dynamic Impedance (Note 4)	$I_R - 100 \mu A, f = 20Hz$		0.2	0.60		1			1		Ω
Reverse Breakdown Voltage Change with Current (Note 4)	$10\mu A \leq I_R \leq 1mA$ $1mA \leq I_R \leq 20mA$		1.0 10				2.0 20			2.0 20	mV
Min. Operating Current (Note 4)			12	18 20		13	20 30		13	20 30	μA μA
Wide Band Noise (Note 5)	$I_R - 100 \mu A,$ $10Hz \leq f \leq 10kHz$		120			120			120		μV
Temperature Coeff. (Note 6)			25			50			100	150	ppm/°C
Long Term Stability (Note 5)	$T_A = 25^\circ C \pm 1^\circ C$ $T = 1000 Hr$		20			20			20		ppm

AMS285-2.5/AMS385-2.5

Note 1: Absolute Maximum Ratings indicate limits beyond which damage to the device may occur. Operating Ratings indicate conditions for which the device is intended to be functional, but do not guarantee specific performance limits. For guaranteed specifications and test conditions, see the Electrical Characteristics. The guaranteed specifications apply only for the test conditions listed.

Note 2: For elevated temperature operation, T_j max is:

AMS285 +125°C
AMS385 +100°C

Thermal Resistance	TO-92	SO-8	SOT-89
ϕ_{JA} (junction to ambient)	170°C/W (0.125" leads)	165°C/W	160°C/W

Note 3: Parameters identified with **boldface type** apply at temperature extremes. All other numbers apply at $T_A = T_J = 25^\circ\text{C}$.

Note 4: Guaranteed and 100% production tested.

Note 5: Guaranteed but not 100% production tested. These limits are not used to calculate average outgoing quality levels.

Note 6: The average temperature coefficient is defined as the maximum deviation of reference voltage at all measured temperatures between the operating T_{MAX} and T_{MIN} , divided by $T_{MAX} - T_{MIN}$. The measured temperatures are 0°C, 25°C, 70°C and 85°C.

PIN CONNECTIONS

TO-92
Plastic Package (N)

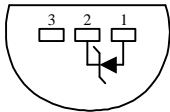

Bottom View

8L SOIC
SO Package (S)

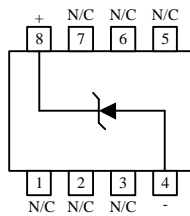

Top View

SOT-89
(L)

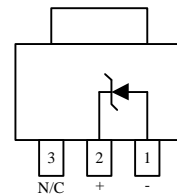

Top View

TYPICAL APPLICATIONS

**Wide Input
Range Reference**

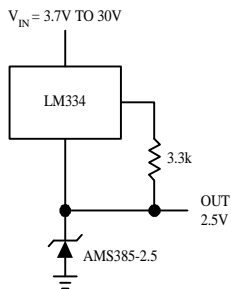

**Micropower Reference
from 9V Battery**

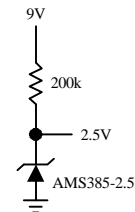

TYPICAL APPLICATIONS (Continued)

0°C - 100°C Thermometer

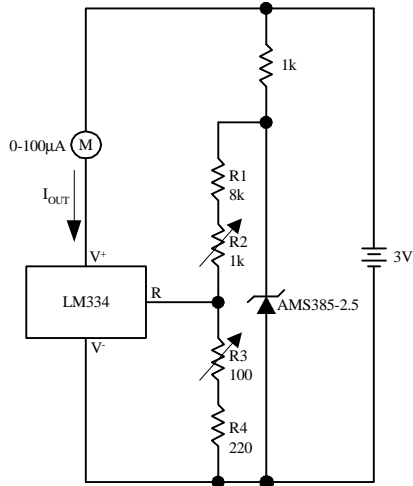

Calibration

1. Short AMS385-2.5, adjust R3 for $I_{OUT} = \text{temp at } 1\mu\text{A}/^\circ\text{K}$
2. Remove short, adjust R2 for correct reading in $^\circ\text{C}$

0°C - 100°C Thermometer

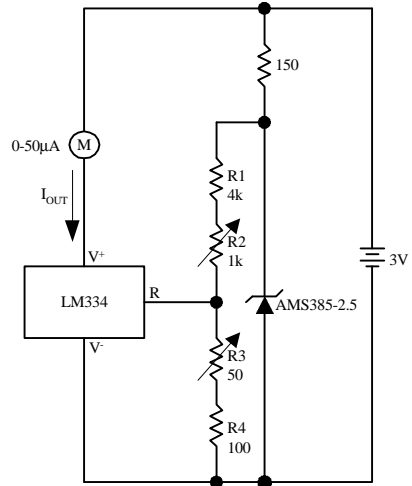

Calibration

1. Short AMS385-2.5, adjust R3 for $I_{OUT} = \text{temp at } 1.8\mu\text{A}/^\circ\text{K}$
2. Remove short, adjust R2 for correct reading in $^\circ\text{F}$

Micropower* 5V Regulator

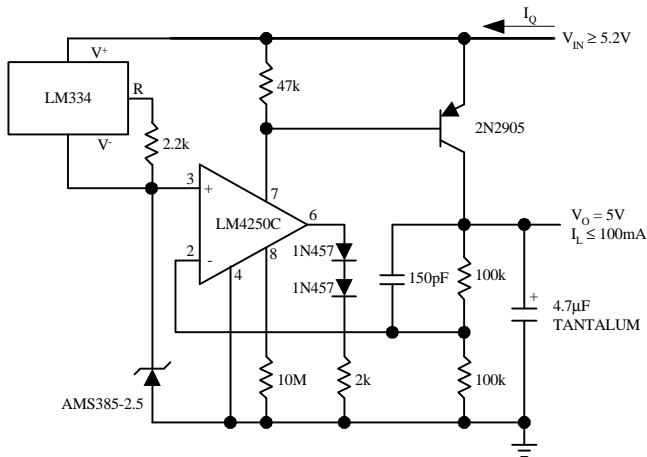

* $I_Q \cong 40\mu\text{A}$

Micropower* 10V Reference

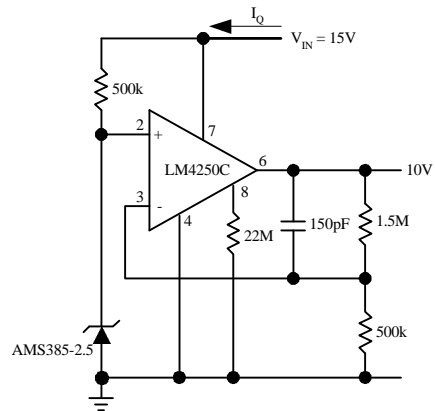

* $I_Q \cong 20\mu\text{A}$ standby current

TYPICAL APPLICATIONS (Continued)

Micropower Thermocouple Cold Junction Compensator

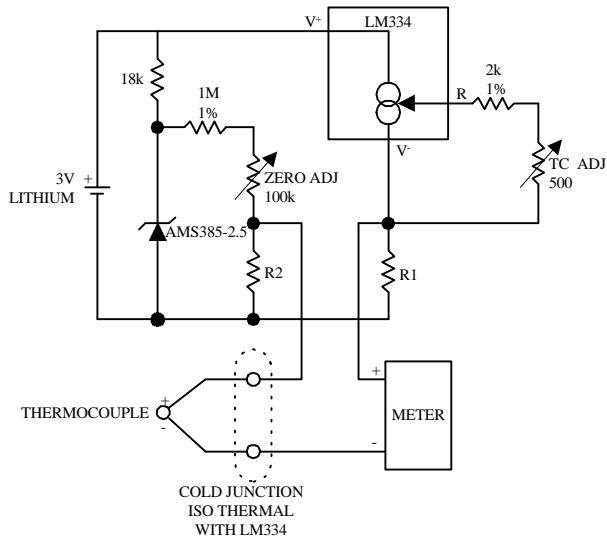

Adjustment Procedure

1. Adjust TC ADJ pot until voltage across R1 equals Kelvin temperature multiplied by the thermocouple Seebeck coefficient.
2. Adjust ZERO ADJ pot until voltage across R2 equals the thermocouple Seebeck coefficient multiplied by 273.2.

Thermocouple Type	Seebeck Coefficient (mV/°C)	R1 (Ω)	R2 (Ω)	Voltage Across R1 @ 25°C (mV)	Voltage Across R2 (mV)
J	52.3	523	1.24k	15.60	14.32
T	42.8	432	1k	12.77	11.78
K	40.8	412	953Ω	12.17	11.17
S	6.4	63.4	150Ω	1.908	1.766

Typical supply current 50μA

Precision 1μA to 1mA Current Sources

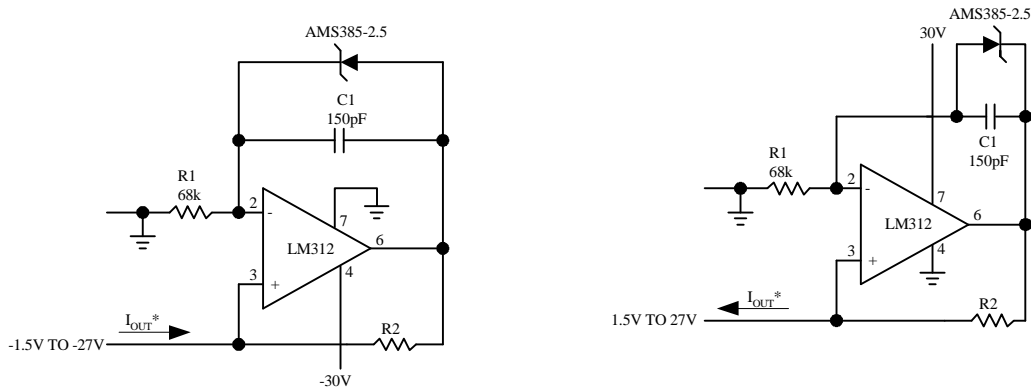

$$*I_{OUT} = 2.5V/R2$$

TYPICAL PERFORMANCE CHARACTERISTICS

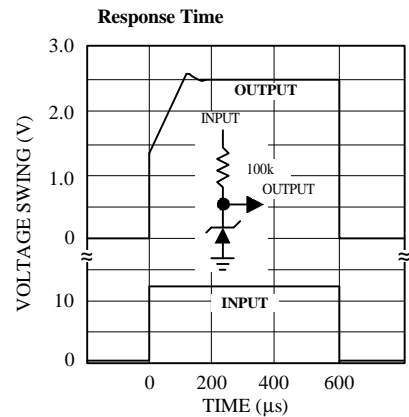
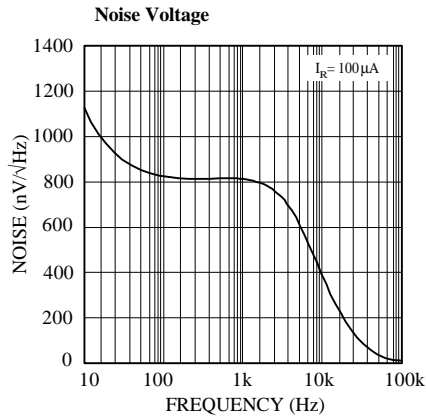
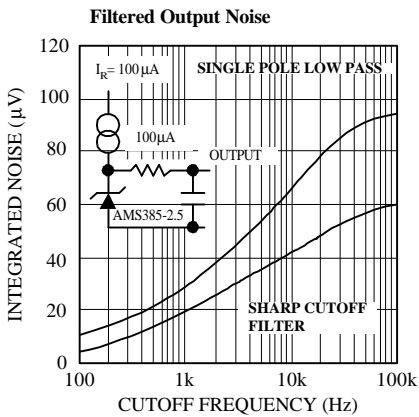
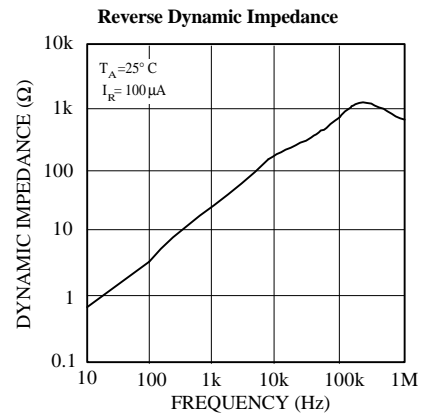
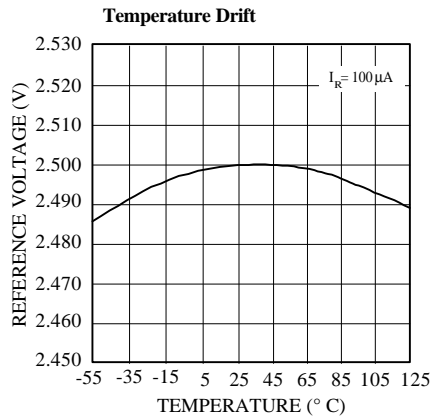
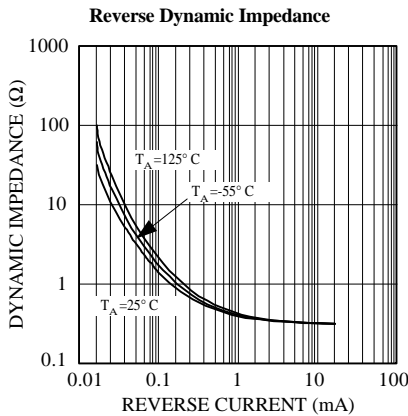
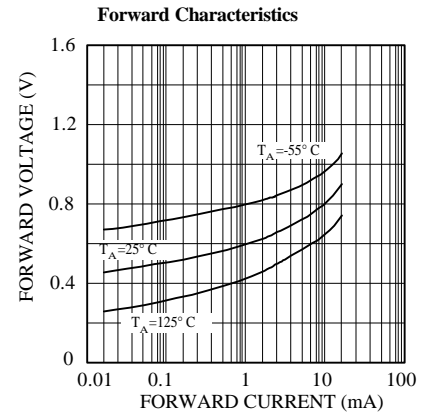
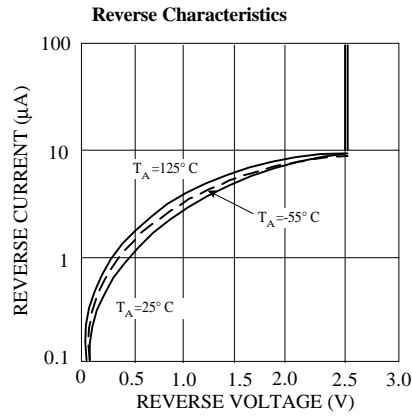
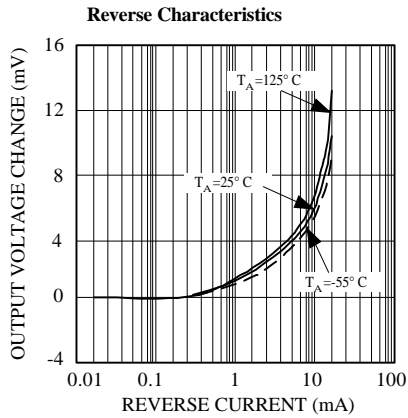

AMS285-2.5/AMS385-2.5

PACKAGE DIMENSIONS inches (millimeters) unless otherwise noted.

3 LEAD TO-92 PLASTIC PACKAGE (N)

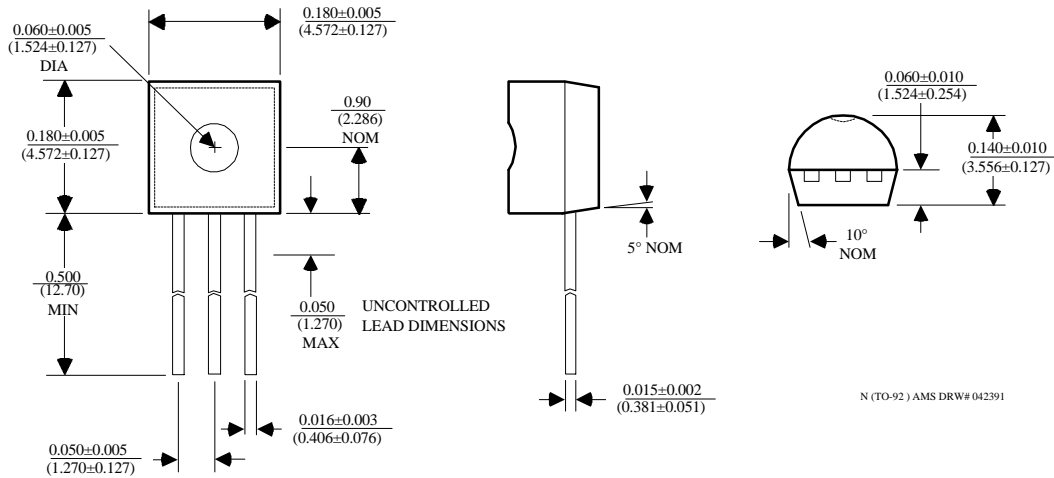

8 LEAD SOIC PLASTIC PACKAGE (S)

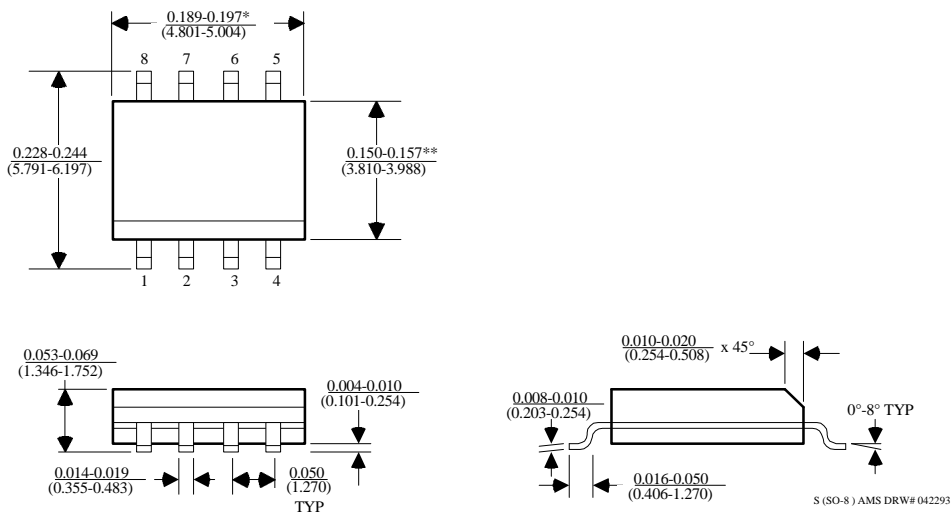

*DIMENSION DOES NOT INCLUDE MOLD FLASH. MOLD FLASH SHALL NOT EXCEED 0.006" (0.152mm) PER SIDE

**DIMENSION DOES NOT INCLUDE INTERLEAD FLASH. INTERLEAD FLASH SHALL NOT EXCEED 0.010" (0.254mm) PER SIDE

AMS285-2.5/AMS385-2.5

PACKAGE DIMENSIONS inches (millimeters) unless otherwise noted (Continued).

SOT-89 PLASTIC PACKAGE (L)

