

D1861B 10 Gbits/s 1310 nm DML Module (–3 dBm)

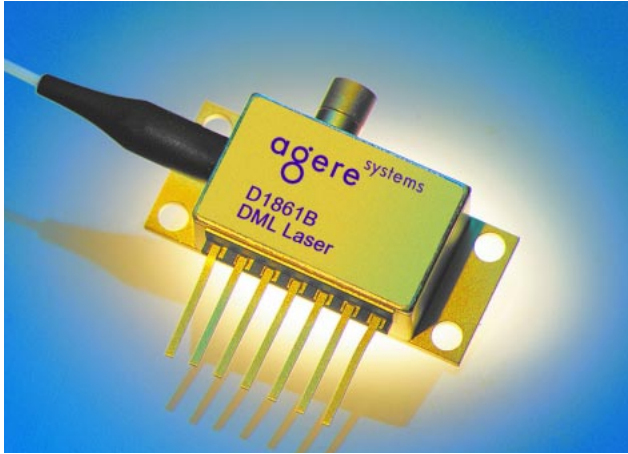

Features

- Direct-modulated 1310 nm laser module characterized for use in 10 Gbits/s operations up to 12 km
- Average optical output power, –3 dBm typical
- Temperature stabilized with internal thermoelectric cooler (TEC), enabling operation within a wide temperature range of –5 °C to +80 °C
- Hermetically sealed optics, isolator on TEC
- GPO* RF connector
- Single-mode fiber pigtail
- High relaxation frequency at low bias

Applications

- SR-1
- SONET/SDH low-cost metro applications
- High-speed data communications
- DWDM equipment drop-side applications

* GPO is a trademark of Gilbert Engineering Co., Inc.

Description

The D1861B direct-modulated laser (DML) module is a cost-effective solution for 10 Gbits/s digital transmission up to 12 km using traditional intracity SMF-28[†] single-mode fiber links. The 1310 nm wavelength eliminates the need for concern about dispersion control over most installed intracity fiber plants. The package contains a high-speed DFB laser chip, thermoelectric cooler, thermistor, optical isolator, and a rear-facet monitor photodiode, which allows for external optical power control.

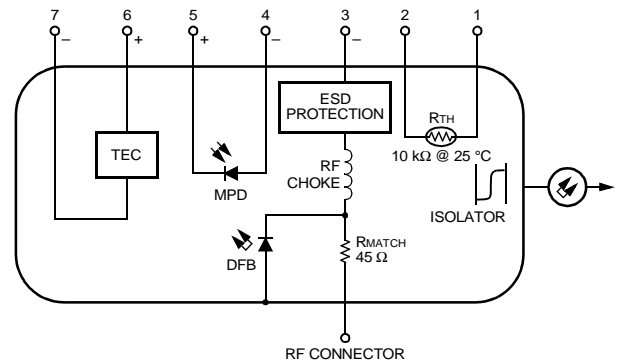

Figure 1. D1861B DML Electrical Schematic

1-1157(F)

Pin Information

Table 1. Pin Descriptions

Pin No.	Description
1	Thermistor
2	Thermistor
3	Laser Cathode (–), dc Bias ¹
4	MPD Anode, (Negative Bias MPD)
5	MPD Cathode
6	Thermoelectric Cooler (+) ²
7	Thermoelectric Cooler (–)

1. Laser anode is case ground mAp-p drive current.

2. A positive current into this pin cools the laser.

† SMF-28 is a trademark of Corning Incorporated.

Absolute Maximum Ratings

Stresses in excess of the absolute maximum ratings can cause permanent damage to the device. These are absolute stress ratings only. Functional operation of the device is not implied at these or any other conditions in excess of those given in the operational sections of the data sheet. Exposure to absolute maximum ratings for extended periods can adversely affect device reliability. RF input shall be ac coupled. It is recommended that a series inductor of 100 μ H be placed external to the device on Pin 3.

Parameter	Symbol	Condition	Min	Max	Unit
Operating Temperature Range	TOP	—	–40	80	°C
Storage Case Temperature Range	Tstg	—	–40	85	°C
Laser Forward Bias	—	TEC On	—	150	mA
Pin 3, Max Positive Voltage ¹	VR	—	—	1	V
Pin 3, Max Positive Current ¹	IR	—	—	200	mA
Reverse Voltage Photodiode	VRPD	—	—	20	V
TEC Current	ITEC	—	—	1.7	A

1. RF connector ac coupled.

Electrical/Optical Characteristics

Table 2. Electrical and Optical Characteristics (Case temperature, –5 °C to +80 °C; laser temperature, 25 °C unless otherwise noted.)

Parameter	Symbol	Condition	Min	Typ	Max	Unit
Average Optical Output Power	PO	IOP = ITH + 30 mA	–5.5 0.28	— —	–1.5 0.71	dBm mW
Threshold Current (BOL)	ITH	—	2	—	30	mA
Wavelength	λ	—	1290	—	1320	nm
Wavelength Tuning Coefficient	$\Delta\lambda_T$	—	—	0.085	—	nm/°C
External Efficiency	η	—	9.4	—	23.8	mW/A
ac Side-mode Suppression Ratio	SMSR	IOP	35	—	—	dB
Optical Isolation	—	—	32	—	—	dB
High-frequency Cutoff (3 dB)	FHIGH	IOP ²	14	—	—	GHz
Low-frequency Cutoff (3 dB)	FLOW	IOP ²	—	—	30	kHz
RF Return Loss, 50 Ω (0.1 GHz–8 GHz)	IS11I	IOP	10	—	—	dB
Rise/Fall Time, 10%–90%	tr/TF	— ¹	—	—	50	ps
Thermoelectric Cooler Current	ITEC	—	—	—	1.3	A
Thermistor Resistance	RTH	—	9.5	10	10.5	k Ω
Thermistor Coefficient	—	—	—	–4.4	—	%/°C
Monitor Photodiode Current	IMPD	IOP	40	—	1500	μ A

1. 10 Gbits/s PRBS 2²³–1, ER = 8.2 dB, @ IOP, TOP = 25 °C, typical 50 mA_p–p drive current.

2. Measurements made with 100 μ H in series with pin 3 (laser cathode).

Characteristic Curve

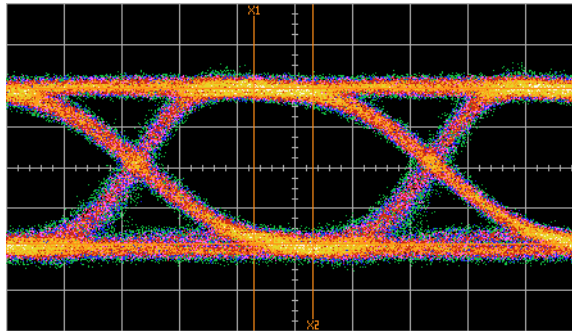
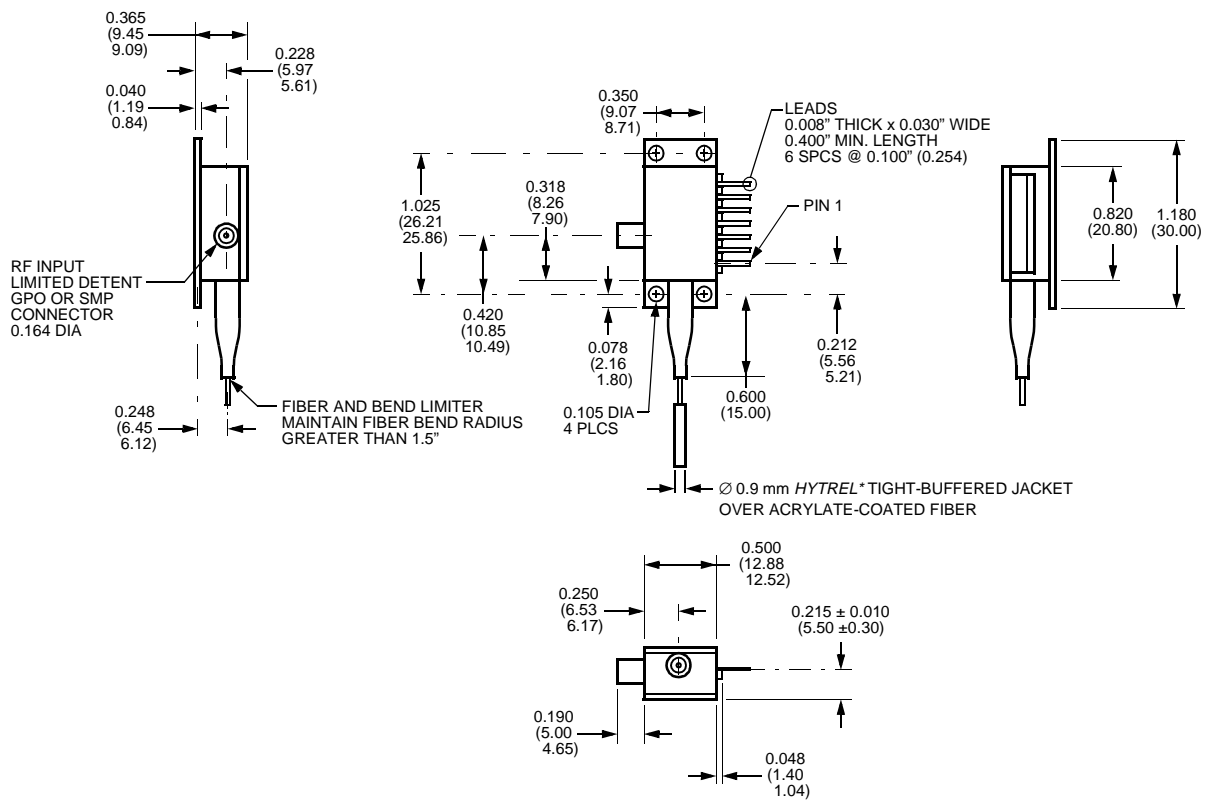

Figure 2. Filtered Optical Eye Pattern (0 km, Fourth Order Bessel Filter, 8.2 dB ER, 20 ps/div)

Outline Diagram

Dimensions are in inches and (millimeters).



* HYTREL is a trademark of E. I. du Pont de Nemours and Company.

Laser Safety Information

Class IIIb Laser Product

FDA/CDRH Class IIIb laser product. All versions are Class IIIb laser products per CDRH, 21 CFR 1040 Laser Safety requirements. All versions are Class 3B laser products per *IEC** 60825-1:1993. The device has been classified with the FDA under an accession number to be determined.

This product complies with 21 CFR 1040.10 and 1040.11.

SMF28 single-mode fiber pigtail and connector

Wavelength = 1.3 μm

Maximum power = 30 mW

Because of size constraints, laser safety labeling (including an FDA Class IIIb label) is not affixed to the module but attached to the outside of the shipping carton.

Product is not shipped with power supply.

Caution: Use of controls, adjustments, and procedures other than those specified herein may result in hazardous laser radiation exposure.

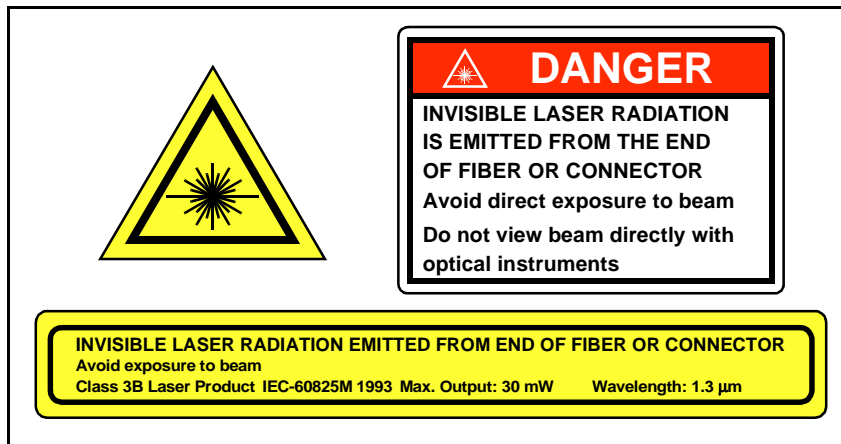

* *IEC* is a registered trademark of The International Electrotechnical Commission.

Ordering Information

Table 3. Ordering Information¹

Device Code	Description	Connector	Pigtail	Comcode
D1861B023	10 Gbits/s DML, 1310 nm	FC/SPC	SMF-28 (1 m min)	TBD
D1861B040	10 Gbits/s DML, 1310 nm	SC/UPC Standard	SMF-28 (1 m min)	TBD
D1861B050	10 Gbits/s DML, 1310 nm	LC	SMF-28 (1 m min)	TBD

1. Other options available. For additional ordering information, please contact an account manager at Opto West, Agere Systems Inc., 1-800-362-3891 (for sales staff, please press option 2).

For additional information, contact your Agere Systems Account Manager or the following:

INTERNET: <http://www.agere.com>

E-MAIL: docmaster@micro.lucent.com

N. AMERICA: Agere Systems Inc., 555 Union Boulevard, Room 30L-15P-BA, Allentown, PA 18109-3286

1-800-372-2447, FAX 610-712-4106 (In CANADA: **1-800-553-2448**, FAX 610-712-4106)

ASIA PACIFIC: Agere Systems Singapore Pte. Ltd., 77 Science Park Drive, #03-18 Cintech III, Singapore 118256

Tel. (65) 778 8833, FAX (65) 777 7495

CHINA: Agere Systems (Shanghai) Co., Ltd., 33/F Jin Mao Tower, 88 Century Boulevard Pudong, Shanghai 200121 PRC

Tel. (86) 21 50471212, FAX (86) 21 50472266

JAPAN: Agere Systems Japan Ltd., 7-18, Higashi-Gotanda 2-chome, Shinagawa-ku, Tokyo 141, Japan

Tel. (81) 3 5421 1600, FAX (81) 3 5421 1700

EUROPE: Data Requests: DATALINE: **Tel. (44) 7000 582 368**, FAX (44) 1189 328 148

Technical Inquiries: OPTOELECTRONICS MARKETING: **(44) 1344 865 900** (Ascot UK)

Agere Systems Inc. reserves the right to make changes to the product(s) or information contained herein without notice. No liability is assumed as a result of their use or application.