



L7590C Telephone Ringing Driver

Features

- Applies a battery-backed, single-ended, sinusoidal ringing signal to the telephone loop
- Ringing capability:
 - 40 V_{rms} into 5 North American REN
 - 30 mA_{peak} into 4 German REN
- Built-in current limiting
- Low power dissipation in idle and ringing modes
- Requires 5 V, a high-value negative dc supply, and a digital input sequence

Description

The L7590C Telephone Ringing Driver produces a low-frequency sinusoidal ringing signal for analog telephone loops. This is accomplished by producing an output pulse stream that is an amplified replica of the digital input. The output is then filtered to produce a sine wave. The peak-to-peak output level is determined by the magnitude of the negative high-voltage dc applied to the device (up to -170 V).

The required input is a 100 kHz CMOS-compatible pulse stream, pulse-width modulated (PWM) at the desired ringing frequency. The output stage consists of one upper and one lower drive transistor with an internal control circuit.

The L7590C IC is optimized for low power dissipation and is available in a 16-pin, surface-mount package.

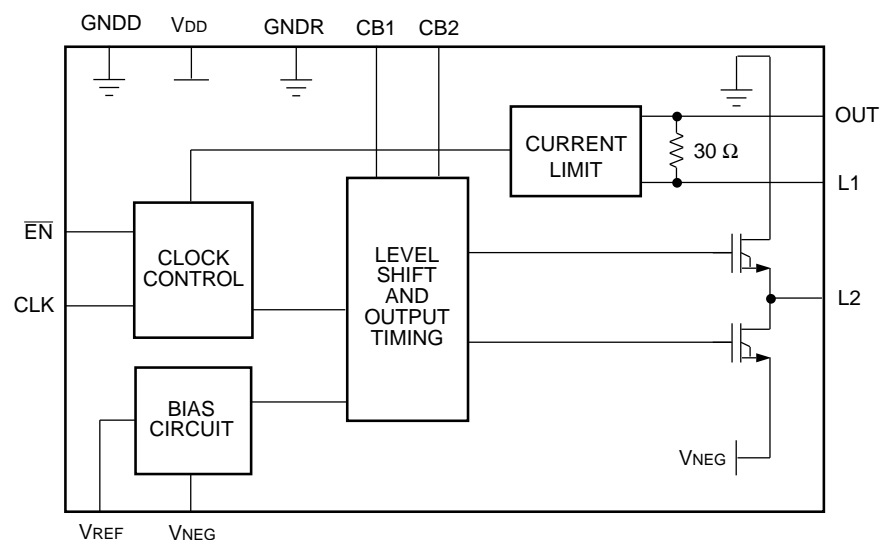

12-3057a (f)

Figure 1. Block Diagram

Pin Information

Pin	Symbol	Type	Name/Function
14	V _{DD}	—	+5 V Power Supply.
3	GNDD	—	Digital Ground.
12	GNDR	—	Ringling Ground.
8	V _{NEG}	—	Negative Power Supply. Determines the swing of the ringing generator. Connect a 1 μ F capacitor from V _{NEG} to V _{REF} .
5	V _{REF}	—	Internal Reference Voltage. Connect a 1 μ F capacitor from V _{REF} to V _{NEG} .
16	CLK	I	Clock. Modulated pulse stream. Low = 0 V. High = V _{DD} .
7	OUT	O	Ringling Generator Output. Connect to ringing relay contact through a filter.
1	CB1	—	Bootstrap Capacitor. Connect a 0.1 μ F capacitor between CB1 and CB2.
2	CB2	—	Bootstrap Capacitor. Connect a 0.1 μ F capacitor between CB1 and CB2.
9	L1	—	Filter Inductor. Connect an inductor to pin L2.
10	L2	—	Filter Inductor. Connect an inductor to pin L1.
15	$\overline{\text{EN}}$	—	Not Enable. A logic low activates the internal circuitry. A logic high puts the device in a low-power powerdown mode.

Absolute Maximum Ratings (T_A = 25 °C)

Stresses in excess of the absolute maximum ratings can cause permanent damage to the device. These are absolute stress ratings only. Functional operation of the device is not implied at these or any other conditions in excess of those given in the operational sections of this data sheet. Exposure to absolute maximum ratings for extended periods may adversely affect device reliability.

Parameter	Min	Typ	Max	Unit
V _{DD}	—	7.0	—	V
V _{NEG}	—	-200	—	V
Timing Input Voltage	-0.5	—	7.0	V
Storage Temperature Range	-40	—	125	°C
Maximum Junction Temperature	—	150	—	°C
Relative Humidity Range	5	—	95	%

Recommended Operating Conditions

Parameter	Min	Typ	Max	Unit
Ambient Temperature	-40	—	85	°C
V _{DD} Supply Voltage	4.75	5.0	5.25	V
V _{NEG} Supply Voltage	-170	—	-130	V

Electrical Characteristics

Electrical characteristics apply for 25 °C. Unless noted, V_{DD} = +5 V, V_{NEG} = -170 V, \overline{EN} = low, L1 = 20 mH (R_{dc} = 20 Ω, C_{eff} = 20 pF), CLK = 100 kHz. Positive currents flow into the device. Typical is defined as 25 °C.

Parameter	Min	Typ	Max	Unit
Power Supply—Idle (CLK = H or L, \overline{EN} = high, dc):				
I _{DD}	—	—	1	mA
I _{NEG}	—	—	-50	μA
Power Dissipation	—	—	13.5	mW
Power Supply—Active, No Load:				
I _{DD}	—	—	3	mA
I _{NEG}	—	-3.2	-8	mA
Power Dissipation	—	—	1.38	W
Efficiency = $\{[(V_{OUT})^2/R_{LOAD}]/(V_{NEG} \cdot I_{NEG})\}$:				
Sinking Current, R _{LOAD} = 1400 Ω Load to GND	40	80	—	%
Sourcing Current, R _{LOAD} = 1400 Ω Load to V _{NEG}	40	80	—	%
ON-resistance:				
CLK = H, I _{OUT} = -20 mA	0	10	20	Ω
CLK = L, I _{OUT} = +20 mA	0	10	20	Ω
Current Limit	25	—	40	mA _{peak}

Functional Description

Ringer Requirements

This discussion highlights some of the requirements in the United States and Germany. Beginning with the telephone set ringer to be powered, the United States requires 40 V_{rms} to be delivered to the equivalent of five parallel telephone sets, or 5 REN (Ringer Equivalence Number), that translates to $1386\ \Omega + 40\ \mu\text{F}$. In Germany, 30 mA_{peak} must be delivered to four parallel telephone sets. In Germany, 4 REN have an impedance of $450\ \Omega + 3.4\ \mu\text{F}$. The difference results from the impedance of the telephone-set ringers of the two countries.

Ringling Requirements

In Germany, both single-ended ringing and balanced ringing can be used. This is not so in the United States, where some ringers on older equipment have a ground connection at the telephone set, and the signal lead is either the Tip or Ring wire of the twisted pair. This has led to the recommended use of single-ended ringing. Both administrations allow ringing with a negative dc level, known as battery-backed ringing, but in the United States, there is a constraint that this level cannot be more negative than $-75\ \text{V}$.

With the exception of the United States, most worldwide administrations require an injection of a pure sine wave. Depending on the country, the distortion requirement is in the range of 3% to 5%. In the United States, the wave does not need to resemble a sine wave, but it cannot be a square wave. The shape requirement of the wave in the United States is expressed as a crest factor (c.f.). This is the ratio of the peak to the rms voltage of the signal. The requirement is $1.2 < \text{c.f.} < 1.6$.

Operation

On the L7590C, the prefiltered output is a high-voltage replica of the PWM digital signal that is applied to the CLK input. The signal at OUT is produced by level shifting and control of the high-voltage transistors. The level is determined by the magnitude of the negative dc voltage applied to the output stage transistors. The output, ideally, should be an exact time replica of the CLK input to faithfully reproduce the modulating waveform. This high-voltage replica of the CLK input is filtered to leave only the low-frequency, high-voltage sine wave ringing signal. Figure 3, parts A and B, illustrates the PWM signal with relation to the modulating signal frequency. The PWM signal is at a 100 kHz rate and modulated at the desired ringing signal frequency, typically 20 Hz to 30 Hz. Laboratory equipment generation of the required signal is shown in Figure 5. Propagation delays and switching parameters associated with the control circuitry and output stage transistors can cause skewing which will produce a distorted output of the modulating waveform. Skewing is illustrated in Figure 4, parts A, B, and C. The skewing can be seen as an increase in the duty cycle of the L7590C output compared to the input signal duty cycle.

Using the test arrangement as shown in Figure 5, the harmonic distortion of the filtered output of the L7590C was measured with two different loading circuits. With the North American 5 REN ($1386\ \Omega + 40\ \mu\text{F}$) load, the THD was typically 2.0% to 2.5%. With the Germany 4 REN ($450\ \Omega + 3.4\ \mu\text{F}$) load, the THD was typically 1.5% to 2.0%. The 25 Hz output of the HP* 3311A generator showed a typical THD of 1.5% when supplying a signal to the HP 8116A.

A $20\ \Omega$ resistor (R_{LIM}) must be added between L1 and OUT for 5 REN loads.

* HP is a registered trademark of Hewlett-Packard Company.

Application

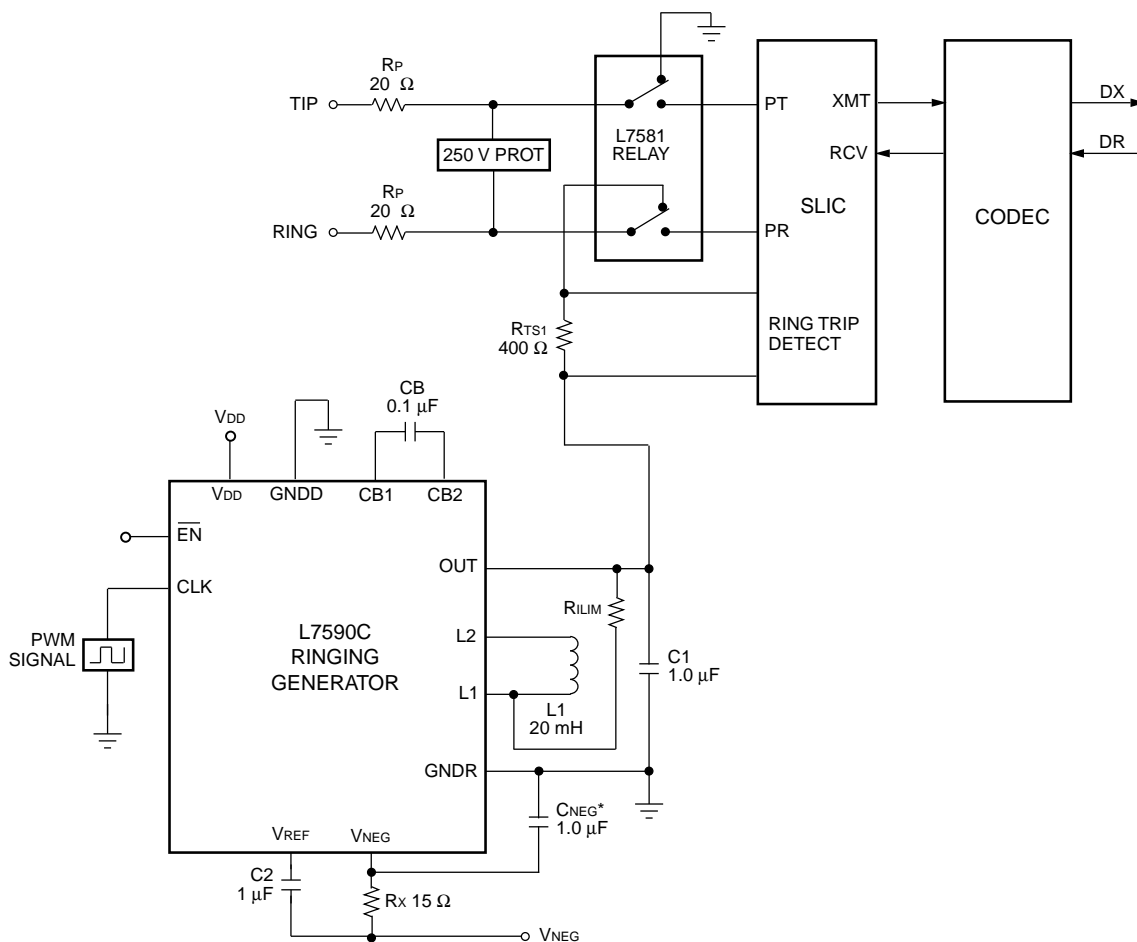

* CNEG connects to VNEG pin at chip.

12-3058.E (F)

Figure 2. Basic Battery-Backed Ringing Application

Table 1. Parts List for Application, Ringing Driver IC

Name	Value	Function
L1	20 mH	Part of LC output filter
C1	1 μ F, 250 V, 20%	Part of LC output filter
C2	1 μ F, 20 V, 20%	VREF filter
CB	0.1 μ F, 10 V, 20%	Voltage doubling capacitor
Rx	15 Ω , 1 W	Hot insertion limiter
RILIM	20 Ω to 100 Ω	Current-limiter adjustment

Application (continued)

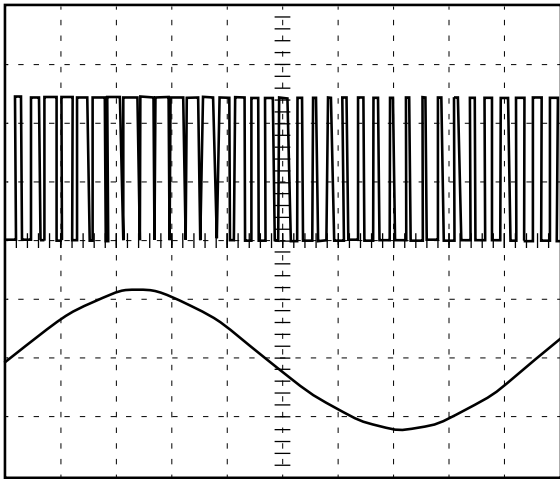

12-3381 (F)

A. Upper = PWM Signal Centered at 100 kHz
Lower = Modulating Signal

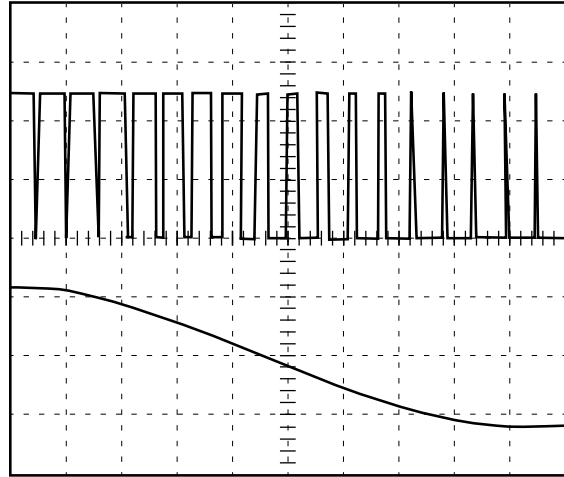

12-3380 (F)

B. Same as A but Expanded

Figure 3. Modulation Waveforms

Application (continued)

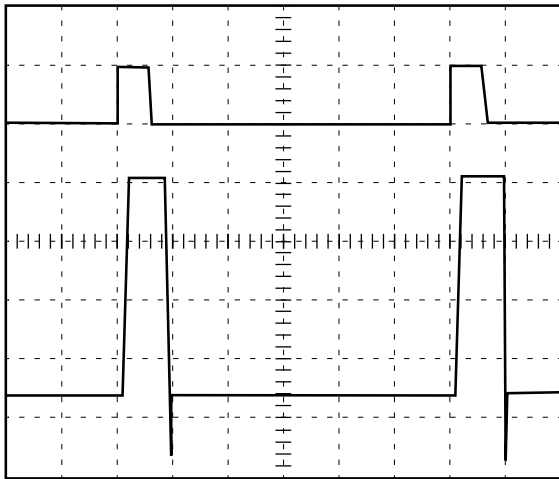

12-3379 (F)

A. Upper = 10% Duty Cycle—CLK Input
Lower = L7590C Output

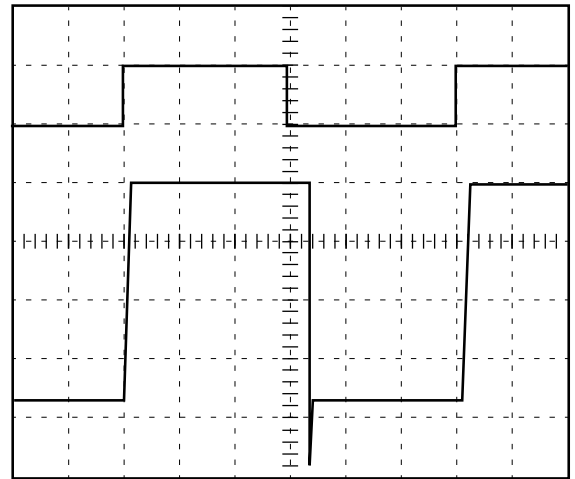

12-3377 (F)

B. 50% Duty Cycle

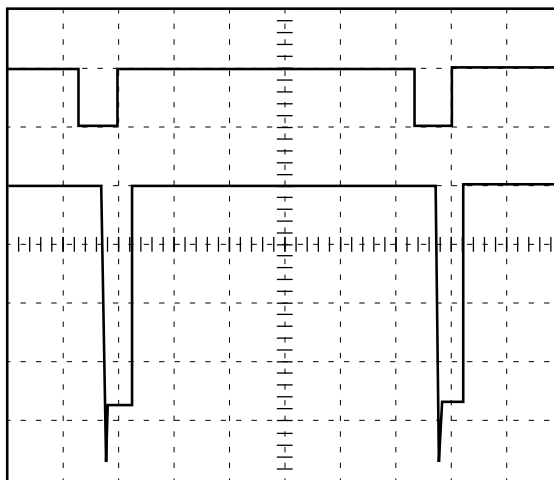

12-3376 (F)

C. 90% Duty Cycle

Note: For all three illustrations above, the positive portion of the L7590C output is skewed to be greater than the CLK input.

Figure 4. Skewing Illustration Waveforms

Application (continued)

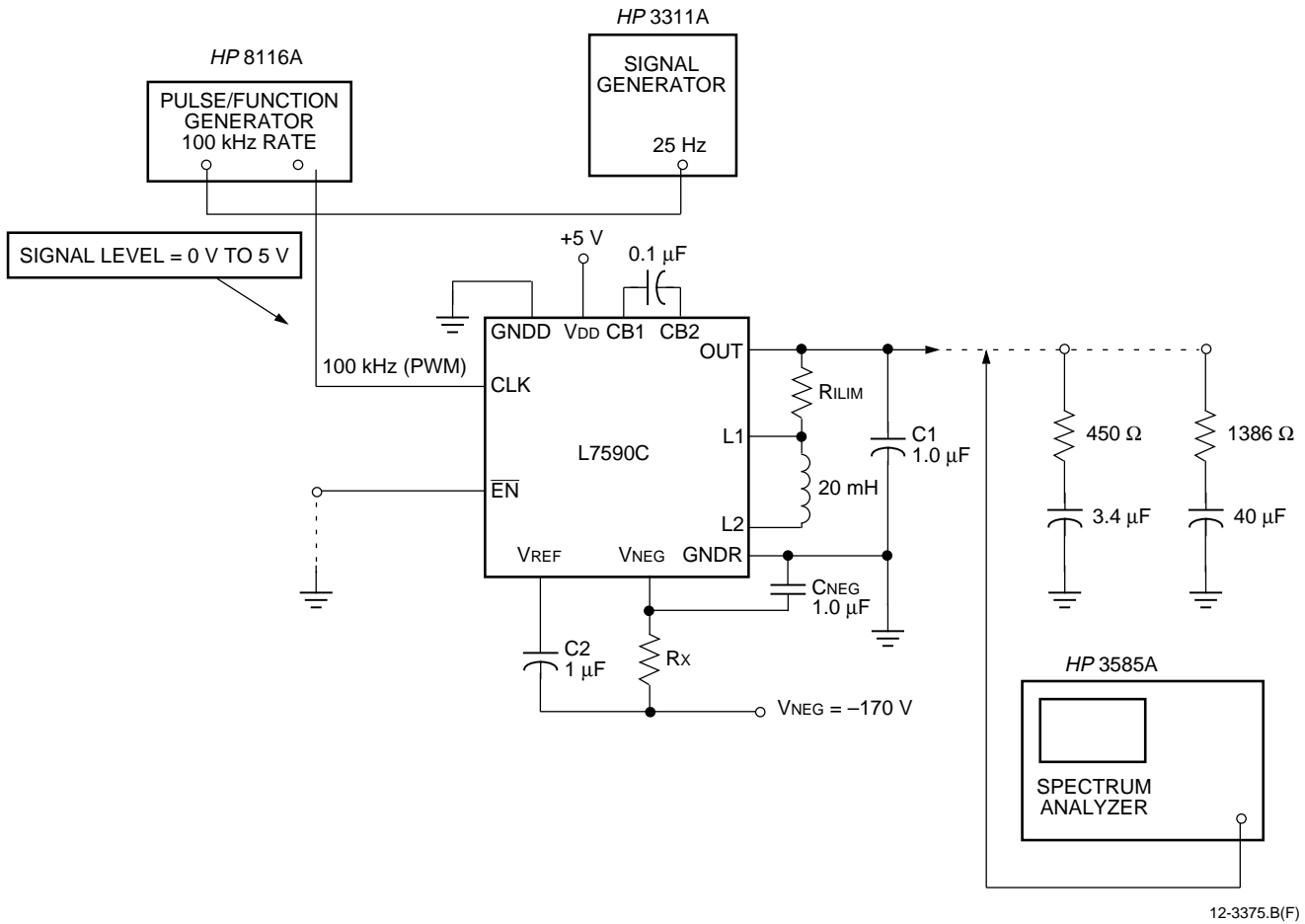

Notes:

$$\text{THD \%} = \frac{\sqrt{E_2^2 + E_3^2 + E_4^2 + \dots}}{\sqrt{E_1^2 + E_2^2 + E_3^2 + E_4^2 + \dots}} \times 100.$$

RX = 15 Ω.

Figure 5. L7590C Test Connections

Outline Diagram

16-Pin, Plastic SOG

Dimensions are in millimeters.

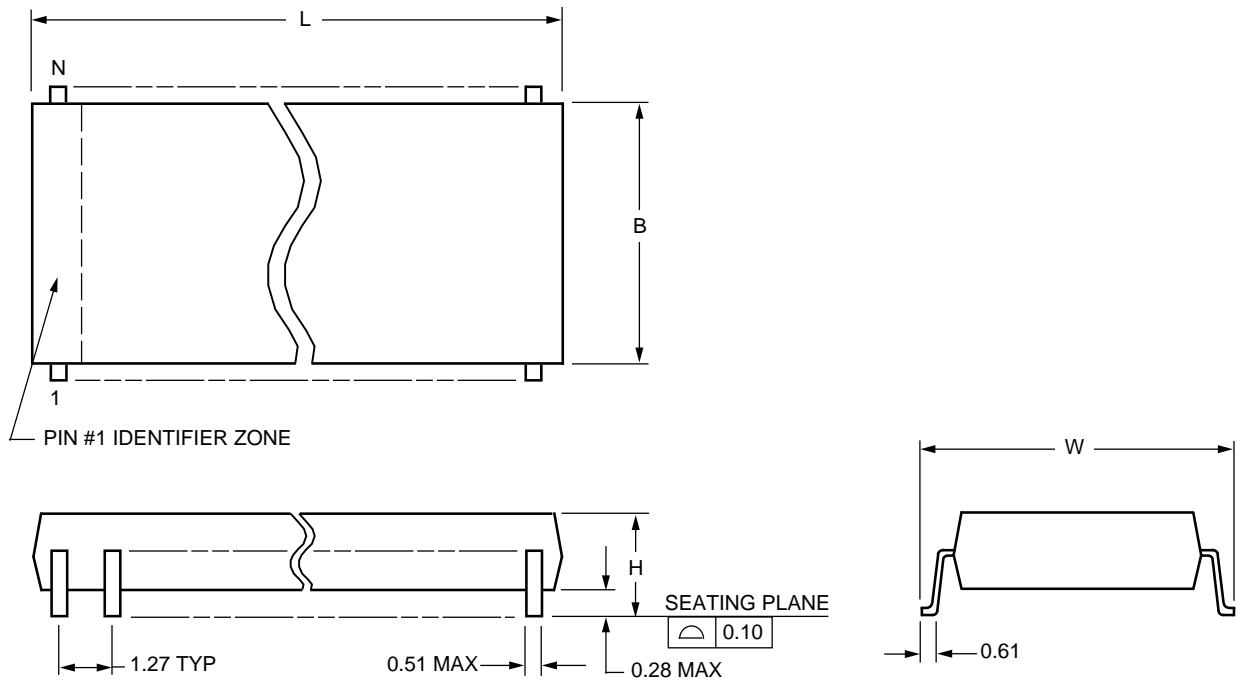

Number of Pins (N)	Maximum Length (L)	Maximum Width Without Leads (B)	Maximum Width Including Leads (W)	Maximum Height Above Board (H)
16	10.49	7.62	10.64	2.67

5-4414r2 (C)

Ordering Information

Device Part No.	Description	Package	Comcode
LUCL7590CAE-D	Telephone Ringing Driver	16-Pin SOG	108191107
LUCL7590CAE-DT	Telephone Ringing Driver	16-Pin SOG (Tape and Reel)	108191115

For additional information, contact your Microelectronics Group Account Manager or the following:

INTERNET: <http://www.lucent.com/micro>

E-MAIL: docmaster@micro.lucent.com

N. AMERICA: Microelectronics Group, Lucent Technologies Inc., 555 Union Boulevard, Room 30L-15P-BA, Allentown, PA 18103
1-800-372-2447, FAX 610-712-4106 (In CANADA: 1-800-553-2448, FAX 610-712-4106)

ASIA PACIFIC: Microelectronics Group, Lucent Technologies Singapore Pte. Ltd., 77 Science Park Drive, #03-18 Cintech III, Singapore 118256
Tel. (65) 778 8833, FAX (65) 777 7495

CHINA: Microelectronics Group, Lucent Technologies (China) Co., Ltd., A-F2, 23/F, Zao Fong Universe Building, 1800 Zhong Shan Xi Road, Shanghai 200233 P. R. China Tel. (86) 21 6440 0468, ext. 316, FAX (86) 21 6440 0652

JAPAN: Microelectronics Group, Lucent Technologies Japan Ltd., 7-18, Higashi-Gotanda 2-chome, Shinagawa-ku, Tokyo 141, Japan
Tel. (81) 3 5421 1600, FAX (81) 3 5421 1700

EUROPE: Data Requests: MICROELECTRONICS GROUP DATALINE: Tel. (44) 1189 324 299, FAX (44) 1189 328 148
Technical Inquiries: GERMANY: (49) 89 95086 0 (Munich), UNITED KINGDOM: (44) 1344 865 900 (Bracknell),
FRANCE: (33) 1 48 83 68 00 (Paris), SWEDEN: (46) 8 600 7070 (Stockholm), FINLAND: (358) 9 4354 2800 (Helsinki),
ITALY: (39) 2 6608131 (Milan), SPAIN: (34) 1 807 1441 (Madrid)

Lucent Technologies Inc. reserves the right to make changes to the product(s) or information contained herein without notice. No liability is assumed as a result of their use or application. No rights under any patent accompany the sale of any such product(s) or information.