

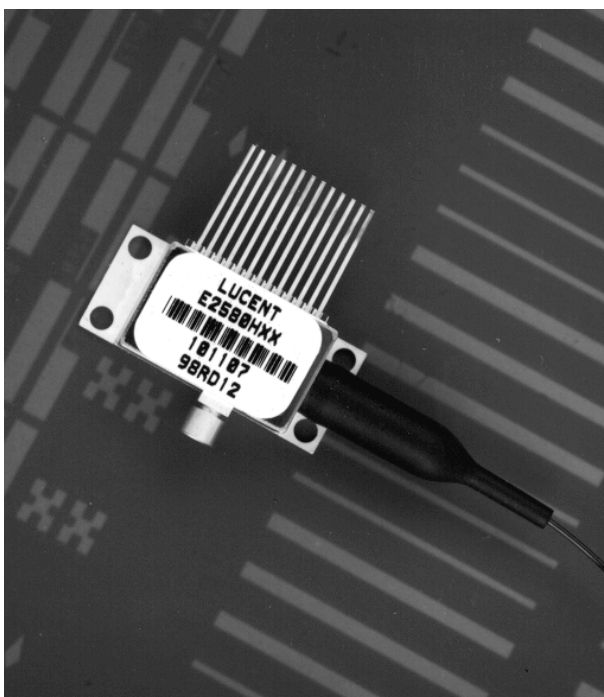

E2560/E2580-Type 10 Gbits/s EML Modules

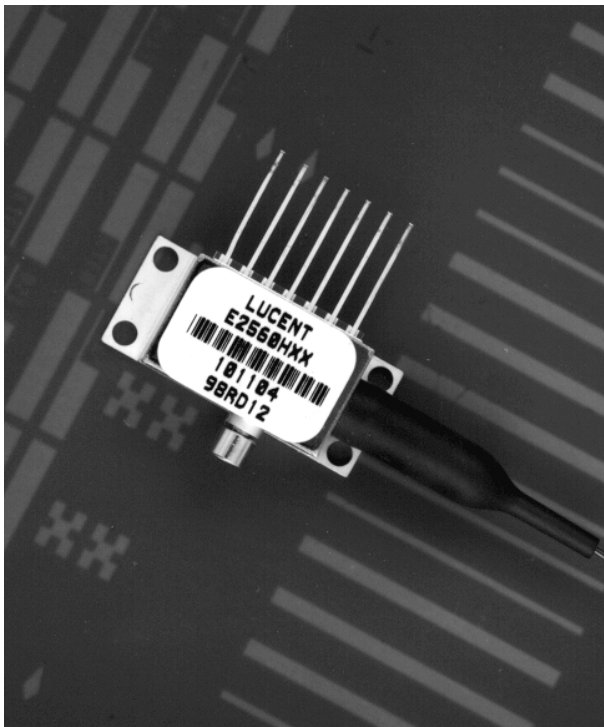

Features

- Integrated electroabsorptive modulator
- 1.5 μm wavelength
- Characterized for 10 Gbits/s operation
- For use up to 80 km at 10 Gbits/s
- Low modulation voltage
- Temperature stabilized
- Available with and without integral driver IC
- Wavelength selectable to ITU-T standards
- Ultrastable wavelength aging for DWDM

Applications

- SONET/SDH applications
- Ultrahigh capacity WDM system application
- High-speed data communication
- Digitized video

Description

The E2560 (without integral driver IC) and E2580 (with integral driver IC) are devices for 10 Gbits/s DWDM or TDM transmission applications, which integrate a CW laser with an electroabsorptive modulator in the same semiconductor chip, and are an extension of Lucent Technologies Microelectronics Groups' existing E2500 series of devices. Both types use a small-profile Gilbert GPO connector to handle the RF signal. The device is typically coupled with a number of erbium-doped fiber amplifiers, such as Lucent Technologies' 1724-series, in order to ensure that sufficient optical power reaches the receiver. These devices can replace external modulators which are often bulkier, more expensive, and require more complex drive electronics than the EML. Both E2560 and E2580 are available for transmission distances of 40 km and 80 km. The package also contains a thermoelectric cooler, thermistor, rear facet monitor photodiode, and an optical isolator.

Description (continued)

The nominal input impedance of the E2560 version is 50 Ω . The package is qualified to the Bellcore TA-TSY-000468 standard.

Both E2560 and E2580 are available in a range of ITU-T wavelengths for use in DWDM systems operating at 10 Gbits/s per channel. The device has excellent wavelength stability, supporting operation at 100 GHz channel spacing over 20 years (assuming an end-of-life aging condition of ± 100 pm). Typically, no external wavelength stabilization is required in systems of this type, using Lucent's E2500 series EMLs. The package also offers excellent stability of wavelength vs. case temperature, with a maximum coefficient of 0.5 pm/ $^{\circ}$ C.

Module Characteristics**Table 1. Module Characteristics**

Package Type	E2560: 7-pin package with GPO connector RF input. E2580: 13-pin package with GPO connector RF input.
Fiber	Standard single-mode fiber.
Connector	ST [®] ; other connectors available on request.
RF Input Impedance	50 Ω .
Bit Rate	10 Gbits/s.

Pin Information**Table 2. Pin Descriptions**

E2560			E2580		
Pin	Abbreviation	Definition	Pin	Abbreviation	Definition
—	—	—	13	TEC–	Thermoelectric cooler–
—	—	—	12	TEC+	Thermoelectric cooler+
—	—	—	11	Vss	Voltage supply to the IC
—	—	—	10	DCA	Duty cycle adjust
—	—	—	9	OA	Optical amplitude adjust
—	—	—	8	NC	No connect/reserved
7	TEC–	Thermoelectric cooler–	7	NC	No connect/reserved
6	TEC+	Thermoelectric cooler+	6	VEA	Modular offset (on-state)
5	BACK DET+	Monitor cathode (+)	5	BACK DET+	Monitor cathode (+)
4	BACK DET–	Monitor anode (–)	4	BACK DET–	Monitor anode (–)
3	LASER+	Laser anode	3	LASER+	Laser anode
2	THERM	Thermistor	2	THERM	Thermistor
1	THERM, LASER–, CASE	Combined thermistor/ laser cathode/case	1	THERM, LASER–, CASE	Combined thermistor/ laser cathode/case

Note: For full details of pin functions and required bias levels for the version with the IC, refer to *E2580 EML with Integral Driver IC: Pin Definitions And Operation* Application Note (TBD):

Target Specifications

Absolute Maximum Ratings

Stresses in excess of the absolute maximum ratings can cause permanent damage to the device. These are absolute stress ratings only. Functional operation of the device is not implied at these or any other conditions in excess of those given in the operational sections of the data sheet. Exposure to absolute maximum ratings for extended periods can adversely affect device reliability.

Table 3. Absolute Maximum Ratings

Parameter	Conditions	Limit	Unit
Laser Diode Reverse Voltage	CW	2	V
Laser Diode Forward Current	CW	150	mA
Optical Output Power	CW	10	mW
Modulator Reverse Voltage	—	5	V
Modulator Forward Voltage	—	1	V
Monitor Diode Reverse Voltage	—	10	V
Monitor Diode Forward Voltage	—	1	V
Storage Temperature	—	-40 to +85	°C
Operating Temperature	—	-10 to +70	°C

Characteristics

Table 4. Optical and Electrical Specifications (Chip operating temp. = 15 °C to 35 °C, except where noted.)

Parameter	Symbol	Conditions	Min	Max	Unit
Threshold Current (BOL)	I_{th}	—	5	35	mA
Forward Voltage	V_F	$I_f = I_{op}$ @ T_{op}	—	2.2	V
Operating Current	I_{op}	—	50	100	mA
Threshold Power	P_{th}	$I_f - I_{th}$ $V_m = I_{op}$	—	80	μ W
Fiber Output Power (Peak)	P_{pk}	$V_m = 0$ V $I_f = I_{op}$	1	—	dBm
Peak Wavelength (Wavelength can be specified to the ITU wavelength channels.)	λ_0	$V_m = 0$ V $T_{laser\ chip} = T_{op}$ $I_f = I_{op}$	1530	1563	nm
Side-mode Suppression Ratio	SMSR	$V_m = 0$ V $I_f = I_{op}, T_{op}$	30	—	dB
Dispersion Penalty $BER = 10^{-10}$	DP	10 Gbits/s* $V_{low} = -1.5$ to -3.0 V, $V_{high} = 0$ V to -1 V $I_f = I_{op}$ @ T_{op}	—	2.0	dB

* Over 720 ps/nm (40 km version), 1440 ps/nm (80 km version).

Target Specifications (continued)**Table 4. Optical and Electrical Specifications** (Chip operating temp. = 15 °C to 35 °C, except where noted.)(continued)

Parameter	Symbol	Conditions	Min	Max	Unit
Modulator/Driver					
Extinction Ratio	ER_{RF}	$V_{in} = 0.5 \text{ Vp-p to } 1.0 \text{ Vp-p}$ 10 Gbits/s (E2580) $V_m = 0 \text{ V to } -2.5 \text{ V}$ 10 Gbits/s (E2560)	11	—	dB
RF Return Loss (E2560) (0 GHz to 6 GHz)	S_{11}	$V_m = -1 \text{ V}$ $I_f = I_{op}$	10	—	dB
RF Return Loss (E2560) (6 GHz to 8 GHz)	S_{11}	$V_m = -1 \text{ V}$ $I_f = I_{op}$	7	—	dB
RF Return Loss (E2560) (8 GHz to 10 GHz)	S_{11}	$V_m = -1 \text{ V}$ $I_f = I_{op}$	5	—	dB
-3 dB Bandwidth (E2560)	BW	$V_m = -1 \text{ V}$ $I_f = I_{op}$	11	—	GHz
RF Return Loss (E2560) (0 GHz to 10 GHz)	S_{11}	$V_{in} = 0.5 \text{ Vp-p to } 1.0 \text{ Vp-p}$ 10 Gbits/s	10	—	dB
Input Voltage (E2580) (Peak to Peak) (ac coupled input)	V_{IN}	—	0.5	1.0	V
Rise/Fall Time (20%—80%)	tr/tf	—	—	40	ps
Monitor Diode					
Monitor Current	I_{bd}	$V_{bd} = 5 \text{ V}$ $I_f = I_{op}$	40	1100	μA
Dark Current	I_d	$V_{bd} = 5 \text{ V}$	—	0.1	μA
Capacitance	C	$V_{bd} = 5 \text{ V}$ $f = 1 \text{ MHz}$	—	25	pF
Thermistor					
Resistance	R_{therm}	$T = 25 \text{ }^\circ\text{C}$	9.5	10.5	$k\Omega$
Thermistor Current	I_{tc}	—	10	100	μA
Thermistor B Constant	B	—	3700	4100	—
Thermoelectric Cooler					
TEC Current	I_{TEC}	†	—	1.1	A
TEC Voltage	V_{TEC}	†	—	2.6	V
TEC Power	P_{TEC}	†	—	2.9	W
TEC Capacity	ΔT	†	55	—	C
Optical Isolation					
Optical Isolation	—	†	30	—	dB
Package					
Wavelength vs. Case Temp.	$d\lambda/dT$	$T_{case} = -10 \text{ }^\circ\text{C to } 70 \text{ }^\circ\text{C}$	—	0.5	$\text{pm}/^\circ\text{C}$

* Over 720 ps/nm (40 km version), 1440 ps/nm (80 km version).

† $T_{case} = 70 \text{ }^\circ\text{C}$, Tlaser chip = 15 °C to 35 °C (E2560), 20 °C to 35 °C (E2580).

Outline Diagram

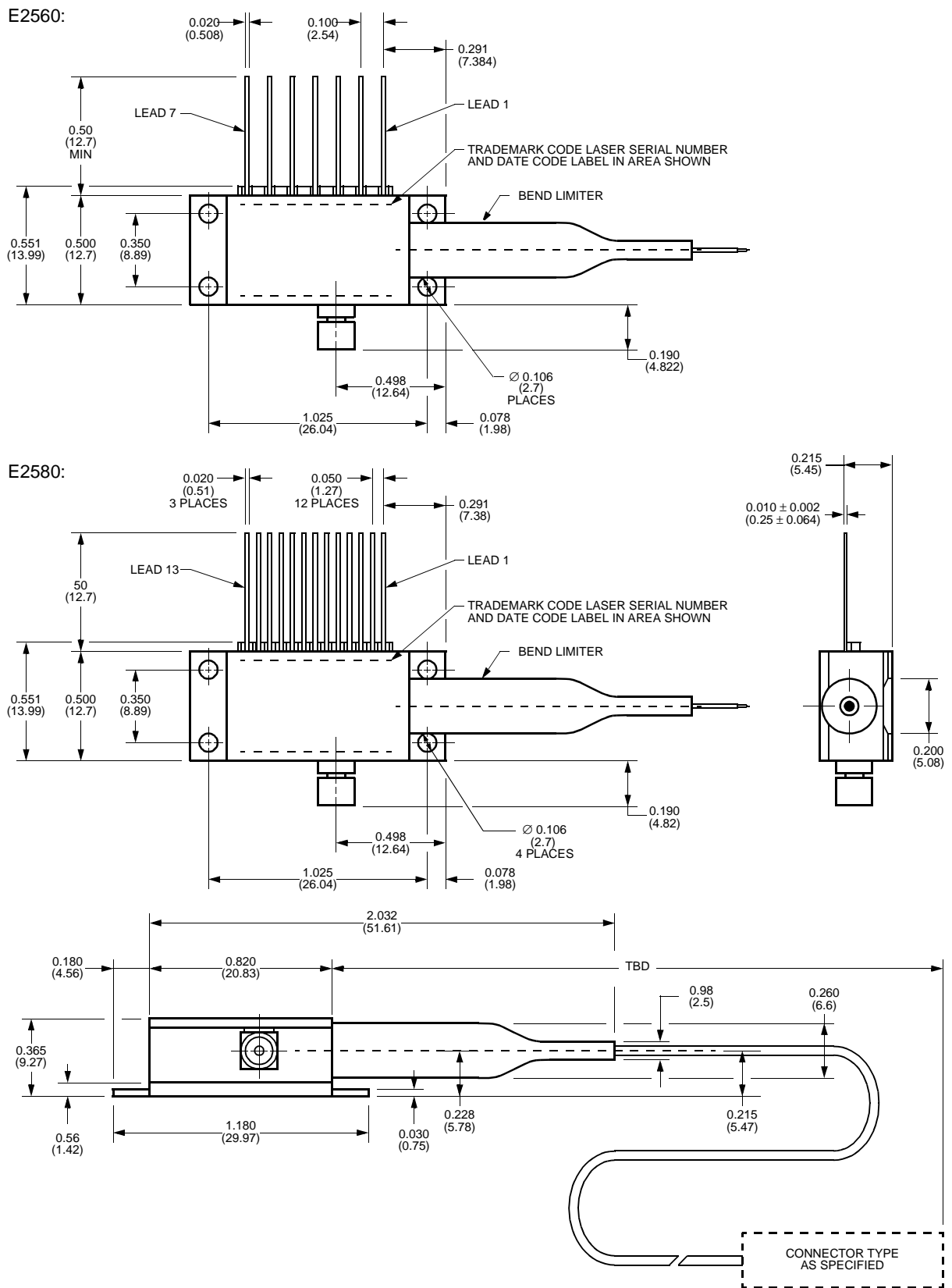

Laser Safety Information

Class IIIb Laser Product

This product complies with 21 CFR 1040.10 and 1040.11.

Single-mode connector

Wavelength = 1.5 μ m

Maximum power = 10 mW

Because of size constraints, laser safety labeling is not affixed to the module but attached to the outside of the shipping carton.

Product is not shipped with power supply.

Caution: Use of controls, adjustments, and procedures other than those specified herein may result in hazardous laser radiation exposure.

For additional information, contact your Microelectronics Group Account Manager or the following:

INTERNET: <http://www.lucent.com/micro>, or for Optoelectronics information, <http://www.lucent.com/micro/opto>
E-MAIL: docmaster@micro.lucent.com
N. AMERICA: Microelectronics Group, Lucent Technologies Inc., 555 Union Boulevard, Room 30L-15P-BA, Allentown, PA 18103
1-800-372-2447, FAX 610-712-4106 (In CANADA: **1-800-553-2448**, FAX 610-712-4106)
ASIA PACIFIC: Microelectronics Group, Lucent Technologies Singapore Pte. Ltd., 77 Science Park Drive, #03-18 Cintech III, Singapore 118256
Tel. (65) 778 8833, FAX (65) 777 7495
CHINA: Microelectronics Group, Lucent Technologies (China) Co., Ltd., A-F2, 23/F, Zao Fong Universe Building, 1800 Zhong Shan Xi Road, Shanghai 200233 P. R. China **Tel. (86) 21 6440 0468, ext. 316**, FAX (86) 21 6440 0652
JAPAN: Microelectronics Group, Lucent Technologies Japan Ltd., 7-18, Higashi-Gotanda 2-chome, Shinagawa-ku, Tokyo 141, Japan
Tel. (81) 3 5421 1600, FAX (81) 3 5421 1700
EUROPE: Data Requests: MICROELECTRONICS GROUP DATALINE: **Tel. (44) 1189 324 299**, FAX (44) 1189 328 148
Technical Inquiries: OPTOELECTRONICS MARKETING: **(44) 1344 865 900** (Ascot UK)

Lucent Technologies Inc. reserves the right to make changes to the product(s) or information contained herein without notice. No liability is assumed as a result of their use or application. No rights under any patent accompany the sale of any such product(s) or information. *ST* is a registered trademark of Lucent Technologies Inc.