

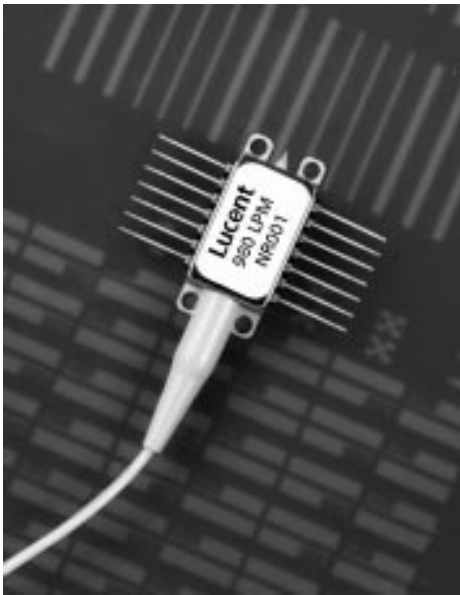

980-Type Ultrahigh-Reliability Pump Laser Module



The 980-Type Ultrahigh-Reliability Pump Laser Module is ideally suited for fiber amplifier-based optical transmission systems that require a long-term life expectancy.

Features

- Extremely high reliability
 - Laser-welded packaging technology used to attain ultrastable long-term operation
 - 29-year life
- Planar InGaAs PIN photodiode monitor for laser back-facet output
- Wide range of stable CW optical output power
- Individually certified for ultrahigh reliability
- InGaAs ridge waveguide 980 nm single-mode laser diode
- Standard low-profile, laser-welded, metal, hermetic, 14-pin butterfly package
- Single-mode fiber with Bragg Grating (FBG) for stable operation
- Stable single spatial mode kink-free operation over a wide range of temperatures and currents

Applications

- Undersea optical transmission systems
- Ultrahigh reliability optical communications for military systems

Description

The 980-Type Pump Laser Module is a precision, high-performance, ultrahigh-reliability lightwave component that provides high output power light, in the 980 nm range. The 980-Type Pump Laser Module is comprised of a single-mode laser diode, PIN back-facet monitor, microlensed single-mode fiber, and a Fiber Bragg Grating (FBG) for improved stability, all encased in a specially designed 14-pin, oxygen free, butterfly package.

The 980-Type Pump Laser Module is capable of providing a wide range of output power in the 974 nm to 984 nm wavelength range for erbium-doped amplifier (EDFA) system application. The pump laser module is designed and individually certified for high-reliability operation and long-term life expectancy. The 980 nm InGaAs laser chip utilizes a ridge guide design for high performance and reliability. Chip and facet parameters are optimized for stabilized optical coupling and efficient pumping of the EDFA. The laser package design also includes a microlensed single-mode fiber and a planar InGaAs PIN back-facet photomonitor assembled in a modular organic-free hermetic package. Laser welding technology is used for critical joints to achieve long-term stability. Data is archived for at least ten years. Each module is fully characterized and traceable. Long-life performance and reliability are ensured through extensive steps of burn-in, overstress, and power aging. The 980-Type Pump Laser Module is available with a typical power output range of 20 mW to 70 mW.

Description (continued)

The 980-Type Pump Laser Module has been specifically designed for undersea optical amplified very high capacity transmission systems that require long-term life expectancy. The extremely stringent reliability requirements imposed on the 980-Type (necessary to achieve long-term system life) are accomplished through careful design, exacting manufacture, and thorough testing. The 980-Type qualification plan consists of a basic set of electro-optic and mechanical tests designed to confirm the performance and reliability of the module over its projected service life under assumed operating conditions. Custom designed, extended qualification test programs can be developed to focus on customer system requirements.

Based on the results of qualification testing, a certification program has been developed to ensure the high-reliability performance of the devices. Each 980-Type device undergoes this certification process where the performance parameters are measured before, during, and after environmental stresses. The certification

results for each 980-Type Pump Laser Module are then examined to ensure that only the pump laser modules that exhibit performance consistent with long-term system operation are selected for product.

Each 980-Type is individually serialized for full traceability and is shipped with the appropriate test data. The 980-Type assembly, test, and certification facilities have all passed the rigorous qualification process required for all facilities that manufacture devices employed in undersea applications. Also, on an ongoing basis, small quantities of product from each manufacturing lot are retained and tested as part of a surveillance program for undersea devices. Each surveillance group is subjected to the complete spectrum of environmental/mechanical stresses required during the qualification process. The surveillance results are reviewed and compiled so that long-term trends can be studied. The reliability performance of the 980-Type Pump Laser Module is a result of a rigorous qualification process combined with an extensive and ongoing surveillance program.

Pinout Information

Top View.

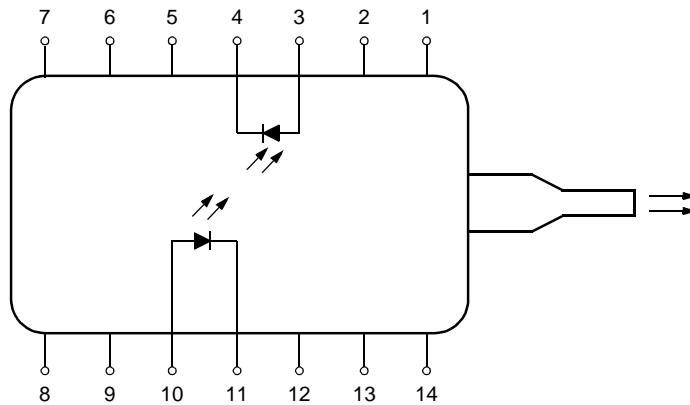

1-675(F).e

Figure 1. Pinout Schematic

Pinout Information (continued)

Table 1. Pinout Descriptions

Pin	Connection
1	Chassis Ground
2	Chassis Ground
3	Photodetector Anode
4	Photodetector Cathode
5	Chassis Ground
6	Chassis Ground
7	Chassis Ground
8	Chassis Ground
9	Chassis Ground
10	Pump Laser Anode
11	Pump Laser Cathode
12	Chassis Ground
13	Chassis Ground
14	Chassis Ground

Handling Precautions

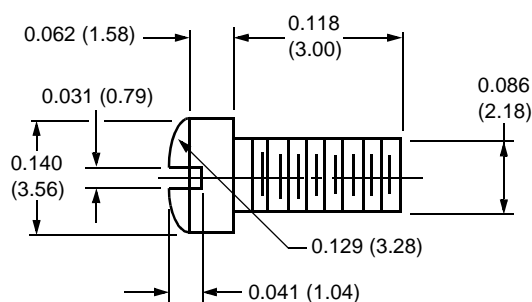

Note: Dimensions are inches and (millimeters).

1-532(F)

Figure 2. Fillister Head Screw

Power Sequencing

Adopt the following sequence for turn-on as a matter of good practice to avoid the possibility of damage to the pump laser module from power supply switching transients:

1. All ground connections
2. Most negative supply
3. Most positive supply
4. All remaining connections

Reverse the order for the proper turn-off sequence.

Mounting Instructions

The minimum fiber-bend radius is 25 mm.

To avoid degradation in performance, mount the module on the board as follows (see Figure 2):

1. Place the bottom flange of the module on a flat heat sink at least 0.5 in. x 1.180 in. (12.7 mm x 30 mm) in size. The surface finish of the heat sink should be better than 32 μ in. (0.8 μ m), and the surface flatness must be better than 0.001 in. (25.4 μ m).

Mount four #2-56 screws with Fillister heads (M2-3 mm) at the four screw hole locations (see Outline Diagram). The Fillister head diameter must not exceed 0.140 in. (3.55 mm). Do not apply more than 2 in./lb. of torque to the screws. To minimize package distortion, it is recommended that a washer is used above and beneath each mounting foot.

Electrostatic Discharge

Caution: This is a Class 0 ESD device which is susceptible to damage as a result of electrostatic discharge (ESD). Take proper precautions during both handling and testing. Follow JEDEC Publication No. 108-A (Dec. 1998).

Lucent employs a human-body model (HBM) and the field-induced charged-device model (CDM) for ESD-susceptibility testing and protection design evaluation. ESD voltage thresholds are dependent on the critical parameters used to define the model. A standard HBM (resistance = 1.5 k Ω , capacitance = 100 pF) is widely used and, therefore, can be used for comparison purposes. The HBM ESD threshold presented here was obtained using these circuit parameters:

Parameter	Value	Unit
Charged-device Model	≥ 200	V
Human-body Model	≥ 400	V

Absolute Maximum Ratings

The LPM will stay certified if it is operated at the maximum rating, for brief periods. Exposure to maximum ratings for extended periods can adversely affect device reliability.

Parameter	Symbol	Min	Max	Unit
Storage Temperature Range	T _{stg}	-20	60	°C
Operating Temperature Range	T _{OP}	0	40	°C
Laser Reverse Voltage	V _R	—	2	V
Laser Forward Current	I _F	—	400	mA
Laser Reverse Current	I _{REV}	—	50	μA
Fiber Output Power	P _F	—	150	mW
PIN Monitor Reverse Voltage	V _{PIN}	—	40	V
PIN Monitor Forward Current	I _{FPIN}	—	2	mA
Pigtail Pull Force (Axial)	F	—	9	N
Pigtail Bend Radius	R _P	25	—	mm
Shock	G	—	100	G
Vibration (10 Hz to 2000 Hz)	V _{IB}	—	5	G

Characteristics

Table 2. Electrical Characteristics

Parameter	Symbol	Min	Max	EOL	Unit
Operating Voltage (CW, 70 mW fiber output)	V _{OP}	—	2.2	2.2	V
Operating Current (CW, 70 mW fiber output)	I _{OP}	100	200	≤250	mA
Monitor Reverse-Bias Voltage	V _{RMON}	—	40	—	V
Monitor Current I = I _{OP}	I _{RMON}	0.3	2.0	2.0	mA
Monitor Dark Current (V _{DET} = -5 V)	I _D	—	25	—	mA

Table 3. Optical Characteristics

Parameter	Symbol	Min	Max	Unit
Optical Output Power Adjustment*	P _O	15	70	mW
Kink Power	P _K	85	—	mW
Center Wavelength	λ _C	974	984	nm
Power Tracking (over 25 °C interval)	ΔP _{OT}	—	0.6	dB
Weighted RMS Spectral Width	Δλ _{RMS}	—	0.7	nm
Output Spectrum Side-mode Suppression	Δλ _{SUPP}	—	20	dB
Optical Return Loss at Pigtail (1525 nm—1570 nm)	RL	13	—	dB
Reliability. Over 29 Years at the Max Operating Conditions of Figure 2.	≤5% failures at ≤25 °C			

* Depending on the exact requirements, there may be two codes (deep and shallow water) necessary.

Characteristics (continued)

Table 4. Physical Characteristics

Parameter	Description
Pigtail Fiber Type	Single-mode Lucent Technologies Optical Fiber Lightguide
Jacket Type	Lucent Technologies Minicord, 1.55 mm O.D.
Fiber Length Between FBG and LPM	≤1.1 m
Fiber Length Beyond FBG	1.5 m—2.0 m
Minimum Radius of Curvature	25 mm
Connector Type	FC/APC

Ordering Information

Device	Part Number	Comcode
Ultrahigh-Reliability Pump Laser Module	980X	TBD

Class IIIb Laser Product

This product complies with 21 CFR 1040.10 and 1040.11.

Single-mode connector

Wavelength = 0.98 μm

Maximum power = 70 mW

Because of size constraints, labeling is not affixed to the module but is contained in the shipping carton.

Product is not shipped with power supply.

Caution: Use of controls, adjustments, and procedures other than those specified herein may result in hazardous laser radiation exposure.

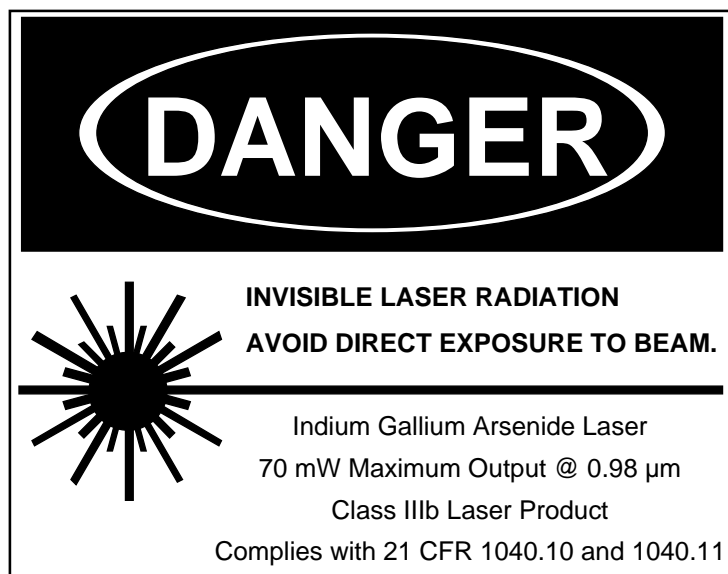

**DANGER: Invisible laser radiation when
disconnected and fiber removed.
AVOID DIRECT EXPOSURE TO BEAM.**

Outline Diagram

Dimensions are in inches and (millimeters). Tolerances are ± 0.005 in. (± 0.127 mm).

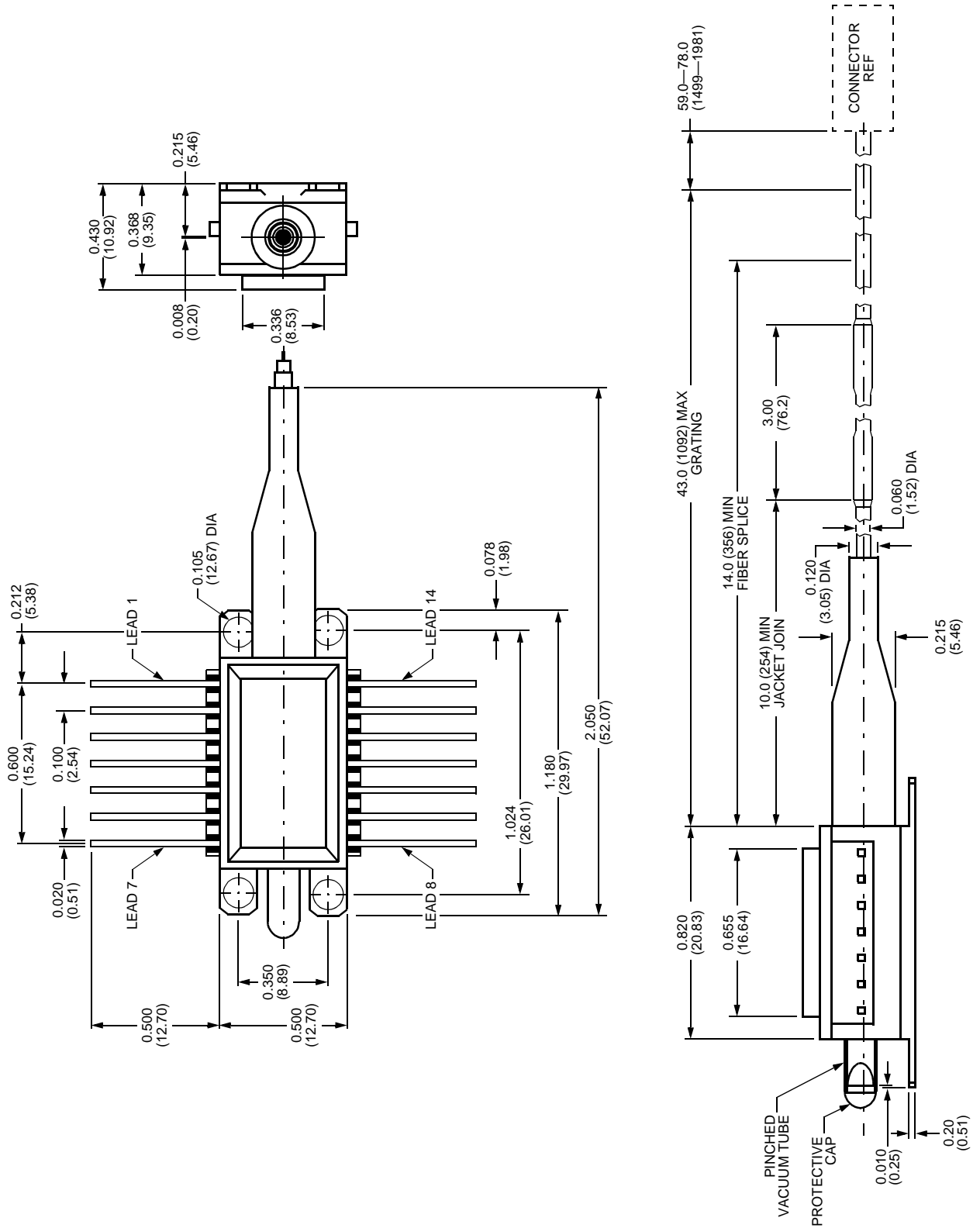

For additional information, contact your Microelectronics Group Account Manager or the following:

INTERNET: <http://www.lucent.com/micro>, or for Optoelectronics information, <http://www.lucent.com/micro/opto>

E-MAIL: docmaster@micro.lucent.com

N. AMERICA: Microelectronics Group, Lucent Technologies Inc., 555 Union Boulevard, Room 30L-15P-BA, Allentown, PA 18103

1-800-372-2447, FAX 610-712-4106 (In CANADA: **1-800-553-2448**, FAX 610-712-4106)

ASIA PACIFIC: Microelectronics Group, Lucent Technologies Singapore Pte. Ltd., 77 Science Park Drive, #03-18 Cintech III, Singapore 118256

Tel. (65) 778 8833, FAX (65) 777 7495

CHINA: Microelectronics Group, Lucent Technologies (China) Co., Ltd., A-F2, 23/F, Zao Fong Universe Building, 1800 Zhong Shan Xi Road, Shanghai 200233 P. R. China **Tel. (86) 21 6440 0468, ext. 316**, FAX (86) 21 6440 0652

JAPAN: Microelectronics Group, Lucent Technologies Japan Ltd., 7-18, Higashi-Gotanda 2-chome, Shinagawa-ku, Tokyo 141, Japan

Tel. (81) 3 5421 1600, FAX (81) 3 5421 1700

EUROPE: Data Requests: MICROELECTRONICS GROUP DATALINE: **Tel. (44) 1189 324 299**, FAX (44) 1189 328 148

Technical Inquiries: OPTOELECTRONICS MARKETING: **(44) 1344 865 900** (Ascot UK)

Lucent Technologies Inc. reserves the right to make changes to the product(s) or information contained herein without notice. No liability is assumed as a result of their use or application. No rights under any patent accompany the sale of any such product(s) or information.

Copyright © 1999 Lucent Technologies Inc.
All Rights Reserved

April 1999
DS99-112LWP

microelectronics group

Lucent Technologies
Bell Labs Innovations

