



Product Specification

AHA3422 StarLite™

***16 MBytes/sec Lossless
Decompressor IC***

2365 NE Hopkins Court
Pullman, WA 99163-5601
tel: 509.334.1000
fax: 509.334.9000
e-mail: sales@aha.com
www.aha.com



advancedhardwarearchitectures

Table of Contents

1.0	Introduction	1
1.1	Conventions, Notations and Definitions	1
1.2	Features	1
1.3	Functional Overview	2
2.0	System Configuration	3
2.1	Microprocessor Interface	3
3.0	Functional Description	5
3.1	Data Ports	5
3.2	DMA Mode	5
3.3	Pad Word Handling in Burst Mode	8
3.4	DMA Request Signals and Status	8
3.4.1	FIFO Threshold	8
3.4.2	Request During an End-of-Record	9
3.4.3	Request Status Bits	9
3.5	Data Format	9
3.6	Odd Byte Handling	10
3.6.1	Input, Pad Bytes and Error Checking	10
3.6.2	Output and Pad Bytes	10
3.7	Video Interface	10
3.7.1	Video Output	10
3.8	Algorithm	11
3.9	Decompression Engine	11
3.10	Prearming	11
3.11	Interrupts	11
3.12	Duplex Printing	12
3.13	Blank Bands	12
3.14	Low Power Mode	12
3.15	Test Mode	12
4.0	Register Descriptions	13
4.1	System Configuration 0, Address 0x00 - Read/Write	15
4.2	System Configuration 1, Address 0x01 - Read/Write	15
4.3	Input FIFO Thresholds, Address 0x02 - Read/Write	16
4.4	Output FIFO Thresholds, Address 0x03 - Read/Write	16
4.5	Decompression Ports Status, Address 0x05 - Read Only	16
4.6	Port Control, Address 0x06 - Read/Write	17
4.7	Interrupt Status/Control 0, Address 0x07 - Read/Write	17
4.8	Interrupt Mask 0, Address 0x09 - Read/Write	18
4.9	Version, Address 0x0A - Read Only	18
4.10	Decompression Record Length, Address 0x0C, 0x0D, 0x0E, 0x0F - Read/Write	18
4.11	Decompression Control, Address 0x18 - Read/Write	19
4.12	Decompression Reserved, Address 0x1A, 0x3A - Read/Write	19
4.13	Decompression Line Length, Address 0x1C, 0x1D - Read/Write	20
4.14	Interrupt Status/Control 1, Address 0x27 - Read/Write	20
4.15	Interrupt Mask 1, Address 0x29 - Read/Write	20
4.16	Decompression Record Count, Address 0x2C, 0x2D - Read/Write	20
4.17	Pattern, Address 0x35 - Read/Write	21
4.18	Decompression Control Prearm, Address 0x38 - Read/Write	21
4.19	Control, Address 0x3F - Read/Write	21

5.0 Signal Descriptions 22

 5.1 Microprocessor Interface 22

 5.2 Data Interface 23

 5.3 Video Interface 23

 5.4 System Control 24

6.0 Pinout 25

7.0 DC Electrical Specifications 27

 7.1 Operating Conditions 27

 7.2 Absolute Maximum Stress Ratings 27

8.0 AC Electrical Specifications 28

9.0 Package Specifications 34

10.0 Ordering Information 35

 10.1 Available Parts 35

 10.2 Part Numbering 35

11.0 Related Technical Publications 36

Appendix A: Additional Timing Diagrams for DMA Mode Transfers 37

Appendix B: Sequential Register Table 44

Figures

Figure 1:	Functional Block Diagram	2
Figure 2:	Microprocessor Port Write (PROCMODE[1:0]="01").	4
Figure 3:	Microprocessor Port Read (PROCMODE[1:0]="01")	4
Figure 4:	Microprocessor Port Write (PROCMODE[1:0]="11").	4
Figure 5:	Microprocessor Port Read (PROCMODE[1:0]="11")	5
Figure 6:	DMA Mode Timing for Single Word Writes, Strobe Condition of DSC=100	6
Figure 7:	DMA Mode Timing for Single Word Reads, Strobe Condition of DSC=100	6
Figure 8:	DMA Mode Timing for Four Word Burst Write, One Wait State, Strobe Condition of DSC=100.	6
Figure 9:	DMA Mode Timing for Four Word Burst Read, One Wait State, Strobe Condition of DSC=100	7
Figure 10:	DMA Mode Timing for Eight Word Burst Write, Zero Wait State, Strobe Condition of DSC=100.	7
Figure 11:	DMA Mode Timing for Eight Word Burst Read, Zero Wait State, Strobe Condition of DSC=100.	7
Figure 12:	FIFO Threshold Example (IFT=4, DSC=2, 1 Word Already in FIFO)	9
Figure 13:	Request vs. End-of-Record, Strobe Condition of DSC=010	9
Figure 14:	Timing Diagram, Video Output	10
Figure 15:	Pinout	26
Figure 16:	Data Interface Timing	28
Figure 17:	Request Deasserts at EOR, Strobe Condition of DSC=0-3, 6-15; ERC=0.	28
Figure 18:	Request Deasserts at EOR, Strobe Condition of DSC=0-3, 6-15; ERC=1.	29
Figure 19:	Request Deasserts at EOR, Strobe Condition of DSC=4 or 5; ERC=0	29
Figure 20:	Request Deasserts at EOR, Strobe Condition of DSC=4 or 5; ERC=1	29
Figure 21:	Output Enable Timing	30
Figure 22:	Video Output Port Timing	30
Figure 23:	Microprocessor Interface Timing (PROCMODE[1]=0)	31
Figure 24:	Microprocessor Interface Timing (PROCMODE[1]=1)	31
Figure 25:	Interrupt Timing	32
Figure 26:	Clock Timing	32
Figure 27:	Power On Reset Timing	33
Figure A1:	DMA Mode Timing for Single Word Writes, Strobe Condition of DSC=000	37
Figure A2:	DMA Mode Timing for Single Word Reads, Strobe Condition of DSC=000	37
Figure A3:	DMA Mode Timing for Four Word Burst Write, One Wait State, Strobe Condition of DSC=000.	37
Figure A4:	DMA Mode Timing for Four Word Burst Read, One Wait State, Strobe Condition of DSC=000	38
Figure A5:	DMA Mode Timing for Eight Word Burst Write, Zero Wait State, Strobe Condition of DSC=000.	38
Figure A6:	DMA Mode Timing for Eight Word Burst Read, Zero Wait State, Strobe Condition of DSC=000.	38
Figure A7:	DMA Mode Timing for Single Word Writes, Strobe Condition of DSC=010	39
Figure A8:	DMA Mode Timing for Single Word Reads, Strobe Condition of DSC=010	39
Figure A9:	DMA Mode Timing for Four Word Burst Write, One Wait State, Strobe Condition of DSC=010.	39
Figure A10:	DMA Mode Timing for Four Word Burst Read, One Wait State, Strobe Condition of DSC=010	40
Figure A11:	DMA Mode Timing for Eight Word Burst Write, Zero Wait State, Strobe Condition of DSC=010.	40
Figure A12:	DMA Mode Timing for Eight Word Burst Read, Zero Wait State, Strobe Condition of DSC=010.	40
Figure A13:	DMA Mode Timing for Single Word Writes, Strobe Condition of DSC=011	41
Figure A14:	DMA Mode Timing for Single Word Reads, Strobe Condition of DSC=011	41
Figure A15:	DMA Mode Timing for Four Word Burst Write, One Wait State, Strobe Condition of DSC=011.	41
Figure A16:	DMA Mode Timing for Four Word Burst Read, One Wait State, Strobe Condition of DSC=011	42
Figure A17:	DMA Mode Timing for Eight Word Burst Write, Zero Wait State, Strobe Condition of DSC=011.	42
Figure A18:	DMA Mode Timing for Eight Word Burst Read, Zero Wait State, Strobe Condition of DSC=011.	42
Figure A19:	DMA Mode Timing for Single Word Writes, Strobe Condition of DSC=111	43
Figure A20:	DMA Mode Timing for Single Word Reads, Strobe Condition of DSC=111	43

Tables

Table 1:	<i>Data Bus and FIFO Sizes Supported</i>	2
Table 2:	<i>Connection to Host Microprocessors</i>	2
Table 3:	<i>Microprocessor Port Configuration</i>	3
Table 4:	<i>Internal Strobe Conditions for DMA Mode</i>	5
Table 5:	<i>Internal Registers</i>	13
Table 6:	<i>Data Port Timing Requirements</i>	28
Table 7:	<i>Request vs. EOR Timing</i>	29
Table 8:	<i>Output Enable Timing Requirements</i>	30
Table 9:	<i>Video Output Port Timing Requirements</i>	30
Table 10:	<i>Microprocessor Interface Timing Requirements</i>	32
Table 11:	<i>Interrupt Timing Requirements</i>	32
Table 12:	<i>Clock Timing Requirements</i>	32
Table 13:	<i>Power On Reset Timing Requirements</i>	33

1.0 INTRODUCTION

AHA3422 is a lossless decompression coprocessor IC for hardcopy systems on many standard platforms. The device is targeted for high throughput and high resolution hardcopy systems.

Multiple record counters, higher clock frequency, advanced banding and duplex printing features enhance this product from the first StarLite™ introduction, AHA3410. Identical decompression algorithm and similar firmware considerations ease migration to this second generation device.

Blank band generation in real time and prearming registers between records enable advanced banding techniques. Bands may be in raw uncompressed, compressed or blank format in the frame buffer. The device processes all three formats and outputs the raster data to the printer engine. Appropriate registers are prearmed when switching from one type to the next. Byte ordering allows full reversal of the image data for duplex printing support. A system may use multiple record counters and End-of-Transfer interrupts to easily handle pages partitioned into smaller records or bands.

This document contains functional description, system configurations, register descriptions, electrical characteristics and ordering information. It is intended for system designers considering a decompression coprocessor in their embedded applications. Software simulation and an analysis of the algorithm for printer and copier images of various complexity are also available for evaluation. A comprehensive Designer's Guide complements this document to assist with the system design. Section 11.0 contains a list of related technical publications.

1.1 CONVENTIONS, NOTATIONS AND DEFINITIONS

- Active low signals have an “N” appended to the end of the signal name. For example, CSN and RDYN.
- A “bar” over a signal name indicates an inverse of the signal. For example, \overline{SD} indicates an inverse of SD. This terminology is used only in logic equations.
- “Signal assertion” means the output signal is logically true.
- Hex values are represented with a prefix of “0x”, such as Register “0x00”. Binary values do not contain a prefix, for example, DSC=000.

- A range of signal names or register bits is denoted by a set of colons between the numbers. Most significant bit is always shown first, followed by least significant bit. For example, VOD[7:0] indicates signal names VOD7 through VOD0.
- A logical “AND” function of two signals is expressed with an “&” between variables.
- Mega Bytes per second is referred to as MBytes/sec or MB/sec.
- In referencing microprocessors, an x, xx or xxx is used as suffix to indicate more than one processor. For example, Motorola 68xxx processor family includes various 68000 processors from Motorola.
- Reserved bits in registers are referred as “res”.
- REQN or ACKN refer to either DI, or DO Request or Acknowledge signals, as applicable.
- NC in pinout description means “no connect”.

1.2 FEATURES

PERFORMANCE:

- 16 MBytes/sec maximum sustained data throughput
- 132 MBytes/sec burst data rate over a 32-bit data bus
- 33 MBytes/sec synchronous 8-bit video out port
- Maximum clock speeds up to 33 MHz
- Average 15 to 1 compression ratio for 1200 dpi bitmap image data
- Advanced banding support: blank bands, prearming

FLEXIBILITY:

- Big Endian or Little Endian; 32 or 16-bit bus width and data byte reordering for duplex printing support
- Prearmable registers
- Scan line length up to 2K bytes
- Interfaces directly with various MIPS, Motorola 68xxx and Cold FIRE, Intel i960 embedded processors
- Pass-through mode passes raw data through the decompression engine
- Counter checks errors in decompression

SYSTEM INTERFACE:

- Single chip decompression solution – no external SRAM required
- Two 16 × 32-bit FIFOs with programmable threshold counters facilitate burst mode transfers

OTHERS:

- Low power modes
- Software emulation program available
- 128 pin quad flat package
- Test pin tristates outputs

Figure 1: Functional Block Diagram

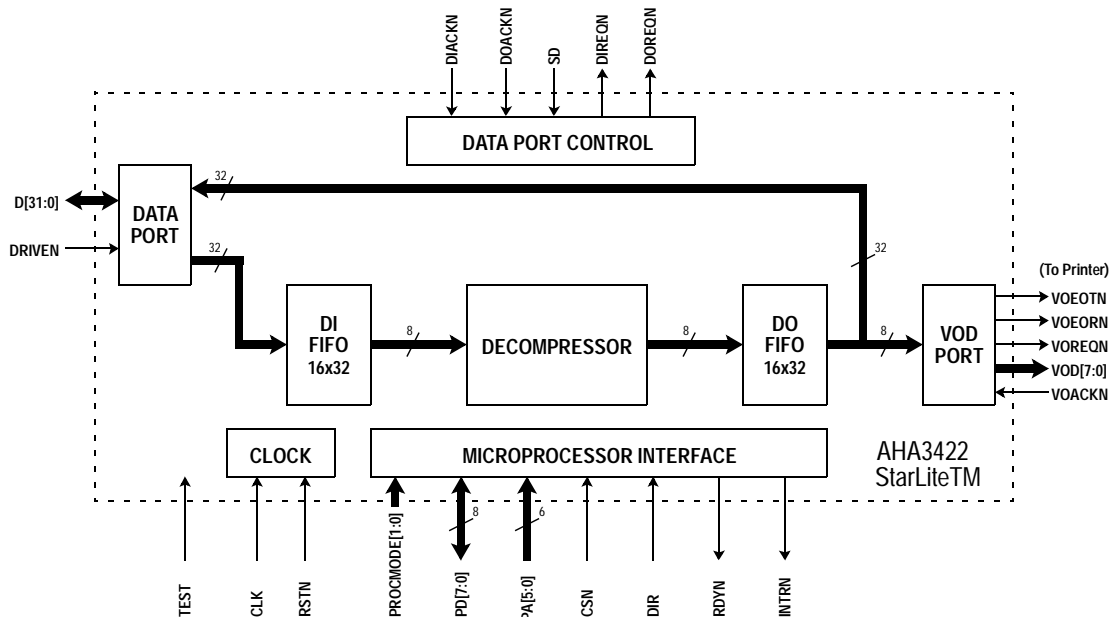

1.3 FUNCTIONAL OVERVIEW

The coprocessor device has two external high speed synchronous data ports capable of transferring once every clock cycle. These are a 32-bit bidirectional data port and a Video Output Data (VOD) port. The 32-bit port is capable of transferring up to 4 bytes per clock. The VOD is capable of up to one byte per clock.

Decompression data is accepted through the 32-bit data port, buffered in the Decompression Input FIFO (DI FIFO) and decompressed. The output data

is made available on the 32-bit data port via the Decompression Output FIFO (DO FIFO) or the 8-bit Video Output port. The decompression engine runs on the 33 MHz clock and is capable of processing an uncompressed byte every other clock.

The two FIFOs are organized as 16×32 each. For data transfers through the two ports, the “effective” FIFO sizes differ according to their data bus widths. The table below shows the size of the data port and the “effective” FIFO size for the various configurations supported by the device.

Table 1: Data Bus and FIFO Sizes Supported

OPERATION	DATA BUS WIDTH	PORT	EFFECTIVE FIFO SIZE
Decompression Data In/Out	32	Data Port	16 x 32
Decompression Data In/Out	16	Data Port	16 x 16
Decompressed Data Out	8	Video Out	16 x 8

Table 2: Connection to Host Microprocessors

PIN NAME	i960Cx	i960Kx	IDT3081	Motorola MCFS102(ColdFIRE)
PA	A	LAD	Latched Address	Latched Address
CSN	\overline{CS}	\overline{CS}	System Dependent	Decoded Chip Select
DIR	W/\overline{R}	W/\overline{R}	\overline{WR}	R/\overline{W}
PD	D	LAD	A/D	A/D[7:0]
SD	\overline{WAIT}	\overline{READY}	System Dependent	System Dependent
RDYN	No Connect	\overline{READY}	\overline{ACK}	\overline{TA}
DRIVEN	\overline{DEN}	System Dependent	System Dependent	System Dependent
CLOCK	PCLK	No Connect	\overline{SYSCLK}	BCLOCK

Movement of data for decompression is performed using synchronous DMA over the 32-bit data port. The Video port also supports synchronous DMA mode transfers. The DMA strobe conditions are configurable for the 32-bit data port depending upon the system processor and the available DMA controller.

Data transfer for decompression is synchronous over the two data ports functioning as DMA masters. To initiate a transfer out of the Video port, the device asserts VOREQN, the external device responds with VOACKN and begins to transfer data over the VOD bus on each succeeding rising edge of the clock until VOREQN is deasserted. The 32-bit port relies on the FIFO Threshold settings to determine the transfer.

The sections below describe the various configurations, programming and other special considerations in developing a decompression system using AHA3422.

2.0 SYSTEM CONFIGURATION

This section provides information on connecting the device to various microprocessors.

Data throughput is internally controlled by writing a control code to the *Control* register. If this feature is not used, the system must control data throughput to remain within the specified limit of 16 MBytes/sec. The control code for this device is 0x0E.

2.1 MICROPROCESSOR INTERFACE

The device is capable of interfacing directly to various processors for embedded application. Table 2 and Table 3 show how to connect to various host microprocessors.

All register accesses are performed on the 8-bit PD bus. The PD bus is the lowest byte of the 32-bit microprocessor bus. During reads of the internal registers, the upper 24 bits are not driven. System designers should terminate these lines with Pullup resistors.

The part provides four modes of operation for the microprocessor port. Both active high and active low write enable signals are allowed as well as two modes for chip select. The mode of operation is set by the PROCMODE[1:0] pins. The PROCMODE[1] signal selects when CSN must be active and also how long an access lasts.

When PROCMODE[1] is high, CSN determines the length of the access. CSN must be at least 5 clocks in length. On a read, valid data is driven onto PD[7:0] during the 5th clock. If CSN is longer than 5 clocks, then valid data continues to be driven out onto PD[7:0]. When CSN goes inactive (high), PD[7:0] goes tristate (asynchronously) and RDYN is driven high asynchronously. CSN must be high for at least two clocks. RDYN is always driven (it is not tristated when PROCMODE[1] is high). The mode is typical of processors such as the Motorola 68xxx.

When PROCMODE[1] is low, accesses are fixed at 5 clocks, PD[7:0] is only driven during the fifth clock, and RDYN is driven high for the first 4 clocks and low during the fifth clock. RDYN is tristated at all other times. Write data must be driven the clock after CSN is sampled low. Accesses may be back to back with no delays in between. This mode is typical of RISC processors such as the i960.

PROCMODE[0] determines the polarity of the DIR pin. If PROCMODE[0] is high, then the DIR pin is an active low write enable. If PROCMODE[0] is low, then the DIR pin is an active high write enable. Figure 2 through Figure 5 illustrate the detailed timing diagrams for the microprocessor interface.

For additional notes on interfacing to various microprocessors, refer to AHA Application Note (ANDC16), *Designer's Guide for StarLite™ Family Products*. AHA Applications Engineering is available to support with other processors not in the Designer's Guide.

Table 3: Microprocessor Port Configuration

PROCMODE[1:0]	DIR	CYCLE LENGTH	EXAMPLE PROCESSOR
00	Active high write	fixed	i960
01	Active low write	fixed	
10	Active high write	variable	
11	Active low write	variable	68xxx, MIPS R3000

Figure 2: Microprocessor Port Write (PROCMODE[1:0]="01")

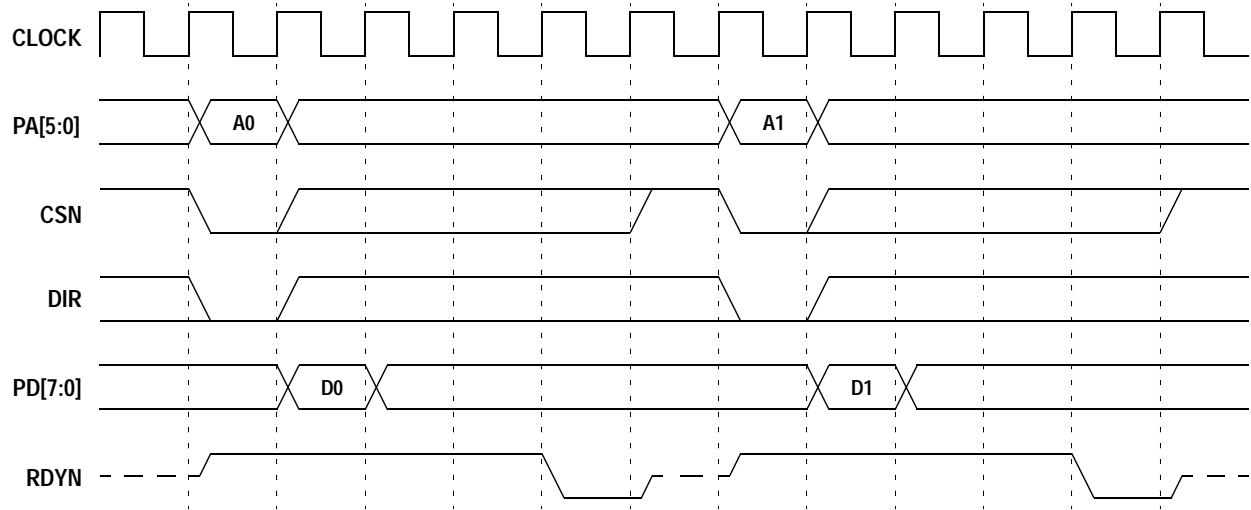

Figure 3: Microprocessor Port Read (PROCMODE[1:0]="01")

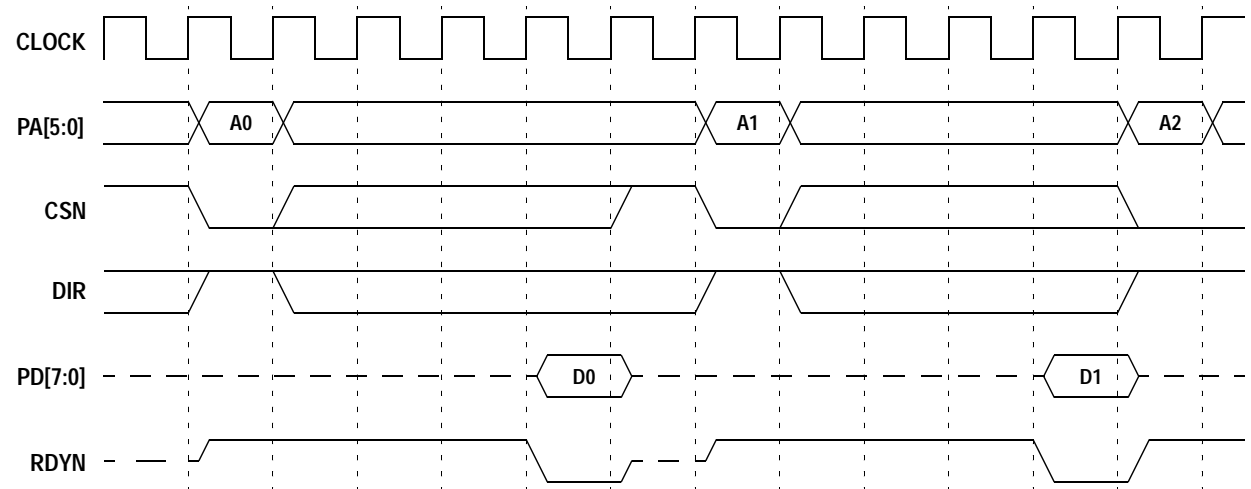

Figure 4: Microprocessor Port Write (PROCMODE[1:0]="11")

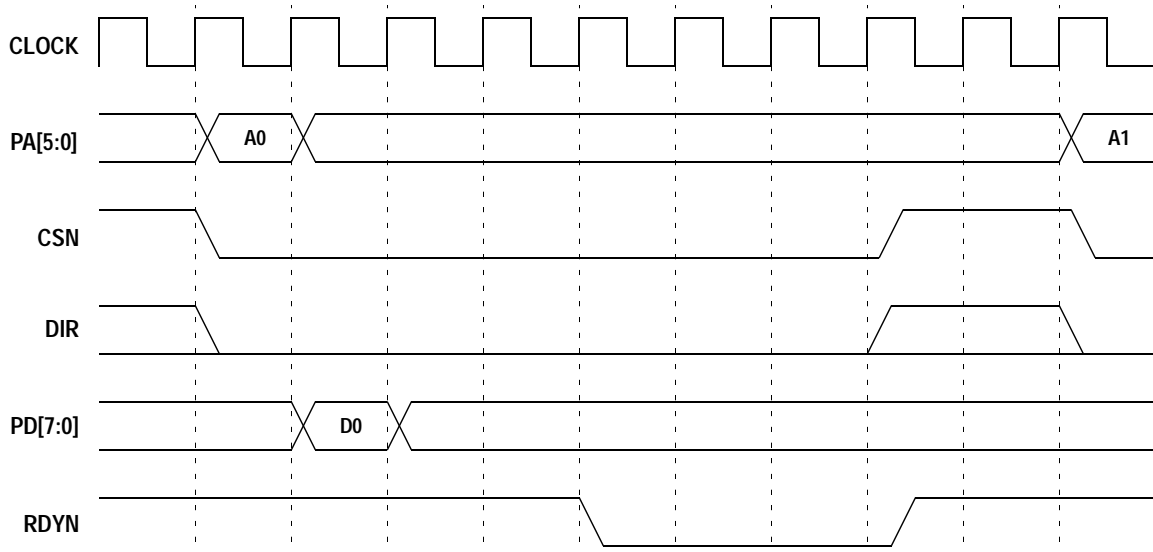
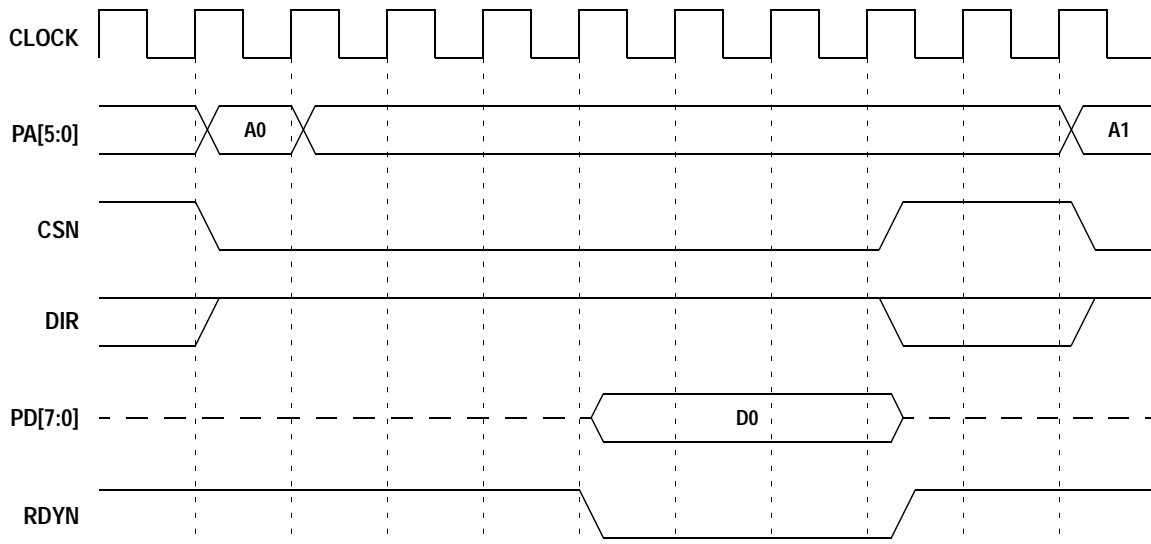

Figure 5: Microprocessor Port Read (PROCMODE[1:0]="11")



3.0 FUNCTIONAL DESCRIPTION

This section describes the various data ports, special handling, data formats and clocking structure.

3.1 DATA PORTS

The device contains one data input port, DI, and one data output port, DO, on the same 32-bit data bus, D[31:0]. Data transfers are controlled by external DMA control. The logical conditions under which data is written to the input FIFO or read from the output FIFO are set by the DSC (Data Strobe Condition) field of the *System Configuration 1* register.

A strobe condition defines under what logical conditions the input FIFO is written or the output FIFO read. DIACKN, DOACKN, and SD pins combine to strobe data in a manner similar to DMA controllers. The DMA Mode sub-section describes the various data strobe options.

3.2 DMA MODE

On the rising edge of CLOCK when the strobe condition is met, the port with the active acknowledge either strobes data into or out of the chip. No more than one port may assert acknowledge at any one time. Table 4 shows the various conditions that may be programmed into register DSC.

Figure 6 through Figure 11 illustrate the DMA mode timings for single, four word and eight word burst transfers for DSC=100 selection. For other DSC settings, please refer to Appendix A. Note that the only difference between odd and even values of DSC is the polarity of SD. Waveforms are only shown for polarities of SD corresponding to specific systems.

Table 4: Internal Strobe Conditions for DMA Mode

DSC[2:0]	LOGIC EQUATION	SYSTEM CONFIGURATION
000	$(\overline{ACKN}) \& (\overline{ACKN_{delayed}}) \& (SD)$	i960Cx with internal DMA controller. SD is connected to WAITN.
001	$(\overline{ACKN}) \& (\overline{ACKN_{delayed}}) \& (\overline{SD})$	No specific system
010	$(\overline{ACKN}) \& (SD)$	General purpose DMA controller
011	$(\overline{ACKN}) \& (\overline{SD})$	i960Kx with external, bus master type DMA controller. SD is connected to RDYN.
100	$(\overline{ACKN_{delayed}}) \& (SD_{delayed})$	No specific system
101	$(\overline{ACKN_{delayed}}) \& (\overline{SD_{delayed}})$	No specific system
110	$(ACKN) \& (\overline{ACKN_{delayed}})$	No specific system
111	$(ACKN) \& (ACKN_{delayed})$	No specific system

$$CKN_{delayed} = ACKN \text{ delayed 1 clock}$$

$$SD_{delayed} = SD \text{ delayed 1 clock}$$

Figure 6: DMA Mode Timing for Single Word Writes, Strobe Condition of DSC=100

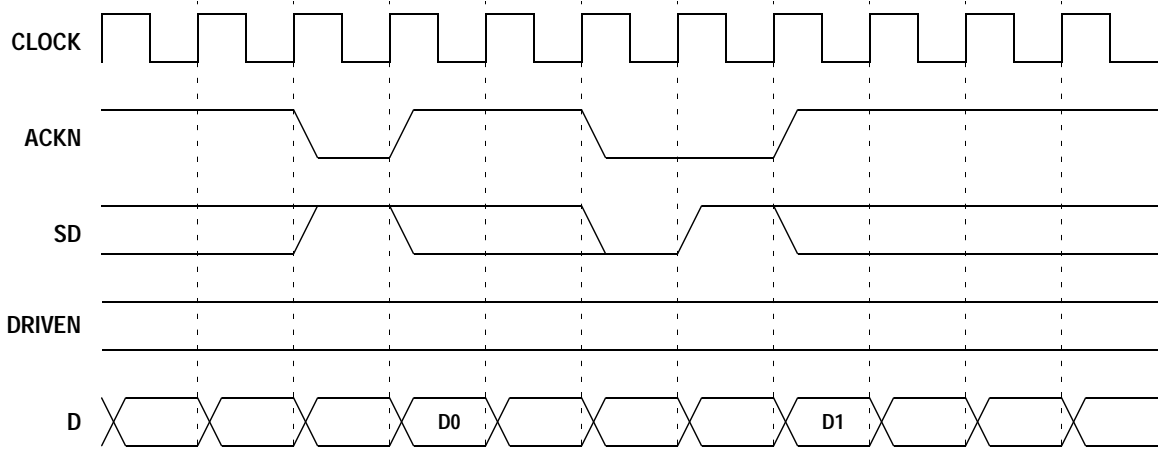

Figure 7: DMA Mode Timing for Single Word Reads, Strobe Condition of DSC=100

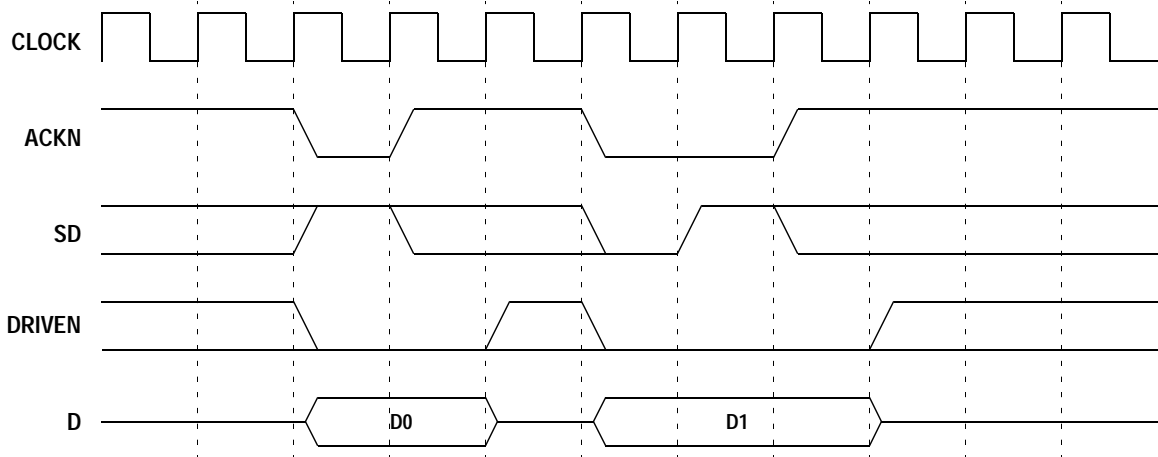

Figure 8: DMA Mode Timing for Four Word Burst Write, One Wait State, Strobe Condition of DSC=100

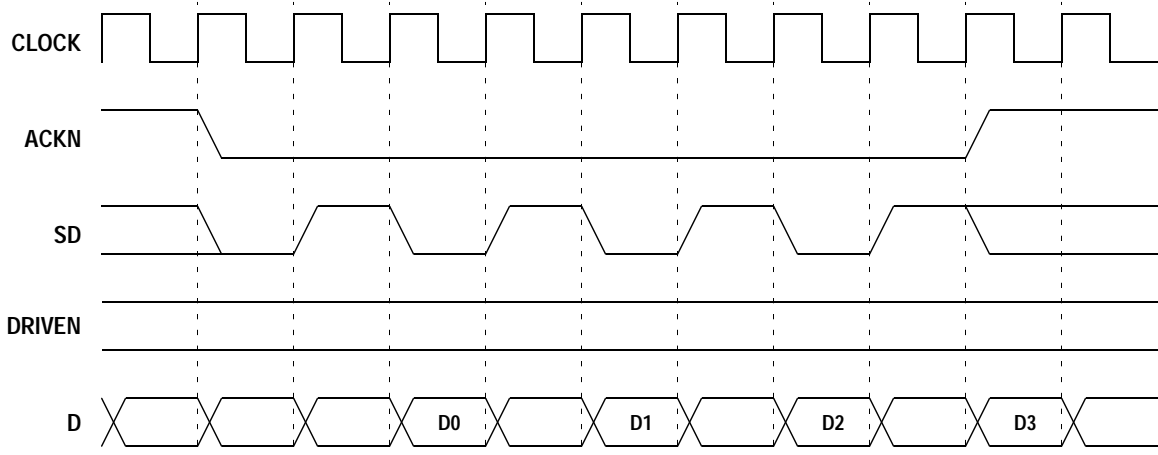

Figure 9: DMA Mode Timing for Four Word Burst Read, One Wait State, Strobe Condition of DSC=100

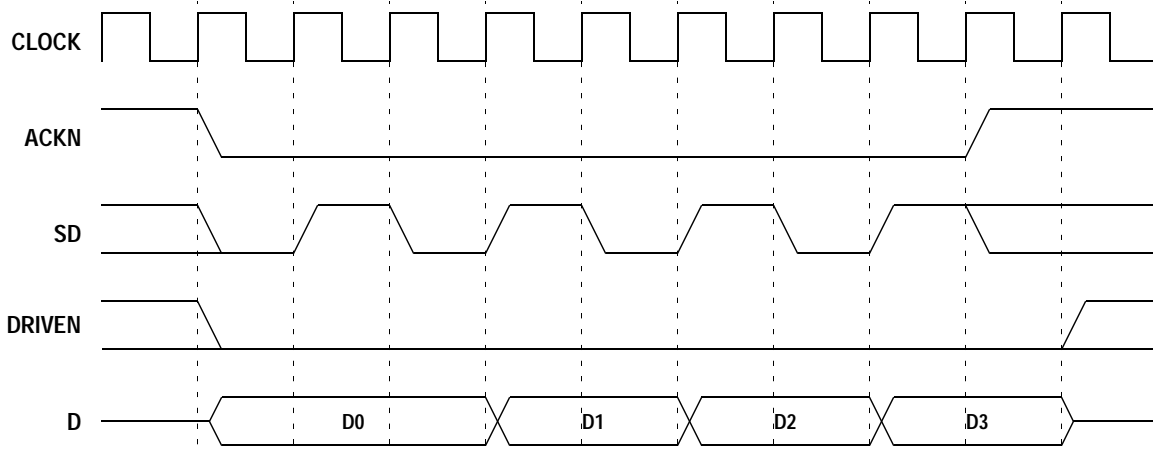

Figure 10: DMA Mode Timing for Eight Word Burst Write, Zero Wait State, Strobe Condition of DSC=100

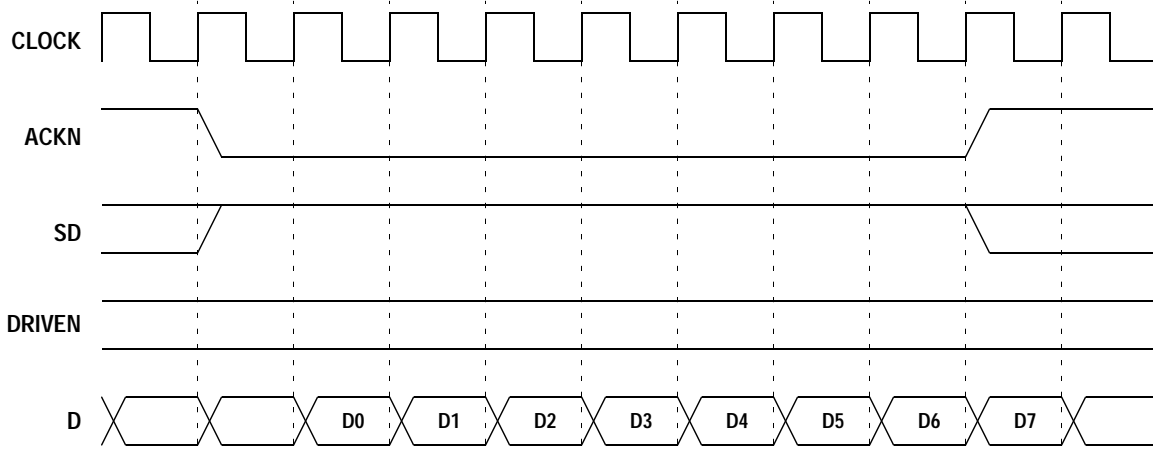
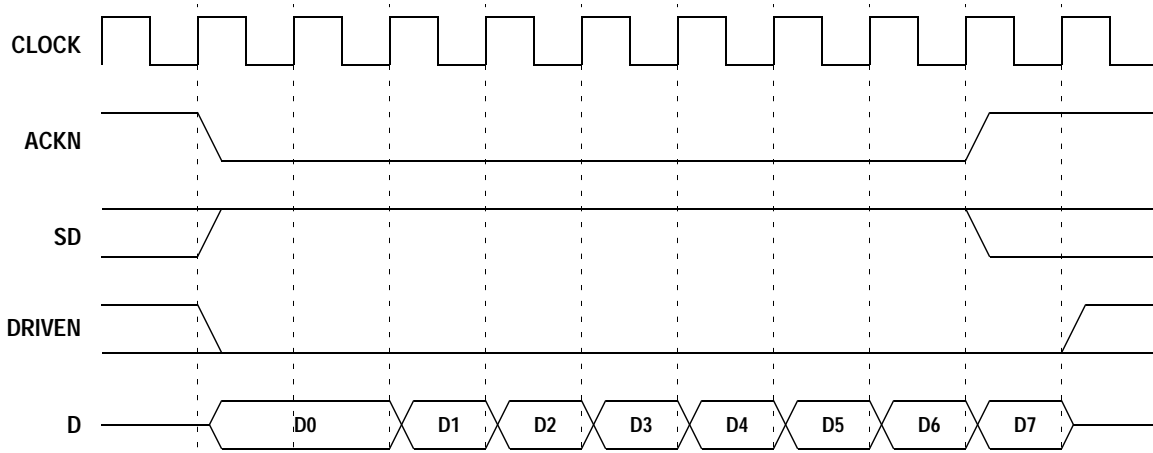

Figure 11: DMA Mode Timing for Eight Word Burst Read, Zero Wait State, Strobe Condition of DSC=100



3.3 PAD WORD HANDLING IN BURST MODE

A method is available to delete pad words during decompression. Pad words may be deleted by using the Decompression Pause on Record Boundaries bit (DPOR), in the Decompression Control register. After the part is paused, the DI FIFO must be reset by asserting the DIRST bit in the Port Control register. Decompressor must also be reset by asserting DDR bit in Decompression Control register.

3.4 DMA REQUEST SIGNALS AND STATUS

The part requests data using request pins (DIREQN, DOREQN). The requests are controlled by programmable FIFO thresholds. Both input and output FIFOs have programmable empty and full thresholds set in the *Input FIFO Threshold* and *Output FIFO Threshold* registers. By requesting only when a FIFO can sustain a certain burst size, the bus is used more efficiently.

Operation of these request signals should not be confused with the request signals on the video port. DIREQN active indicates space available in the input FIFO and DOREQN active indicates data is available in the output FIFO. These request signals being inactive do not prevent data transfers. The data transfers are controlled solely with the particular acknowledge signal being active.

The input request, DIREQN, operates under the following prioritized rules, listed in order of highest to lowest:

- 1) If the FIFO reset in the *Port Control* register is active, the request is inactive.
- 2) If a FIFO overflow interrupt is active, the request is inactive.
- 3) If the FIFO is at or below the empty threshold, the request remains active.
- 4) If the FIFO is at or above the full threshold, the request stays inactive.

The output request, DOREQN, operates under the following prioritized rules, listed in order of highest to lowest:

- 1) If the FIFO reset in the *Port Control* register is active, the request is inactive.
- 2) If the output FIFO underflow interrupt is active, the request is inactive.
- 3) If an EOR is present in the output FIFO, the request goes active.
- 4) If the output FIFO is at or above the full threshold, the request goes active.
- 5) If an EOR is read (strobed) out of the FIFO, the request goes inactive during the same clock as the strobe (if ERC=0), otherwise it goes inactive on the next clock.
- 6) If the output FIFO is at or below the empty threshold, the request goes inactive.

3.4.1 FIFO THRESHOLD

For maximum efficiency, the FIFO threshold should be set in such a way that the decompressor seldom runs out of data from the DI FIFO or completely fills the output FIFO. The FIFO is 16 words deep.

For example, in a system with fixed 8-word bursts, good values for the thresholds are:

$$IET=3, IFT=4, OFT=D, OET=C$$

Setting the input full threshold to one higher than the input empty threshold simply guarantees that the request deasserts as soon as possible. The latency between a word being strobed in and the request changing due to a FIFO threshold condition is 3 clocks. This should be kept in mind when programming threshold values. Refer to Section 4.0 of AHA Application Note (ANDC16), *Designer's Guide for StarLite™ Family Products* for a more thorough discussion of FIFO thresholds. The following figure shows an example of an input FIFO crossing its full threshold.

Figure 12: FIFO Threshold Example (IFT=4, DSC=2, 1 Word Already in FIFO)

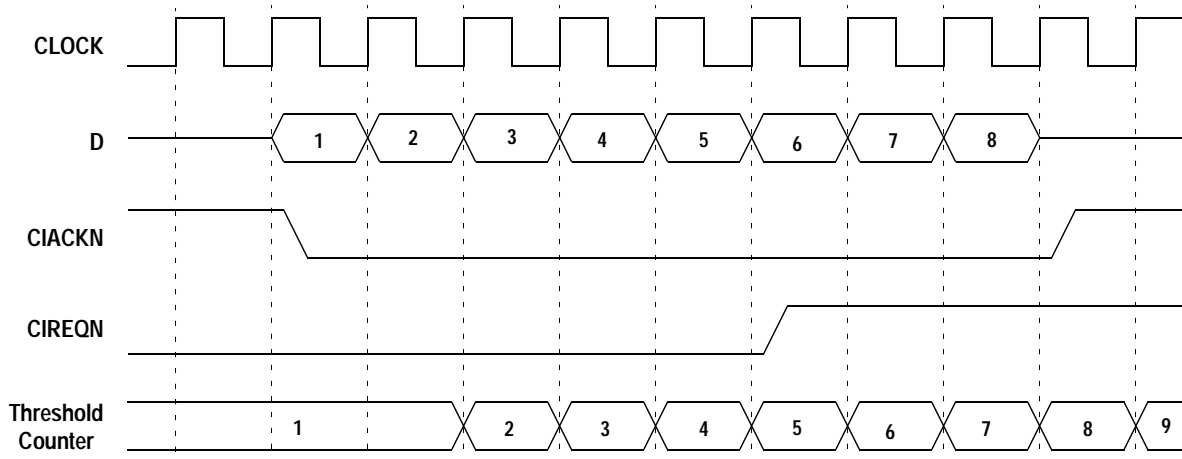

Note: *DIREQN* deasserted when threshold counter exceeded $IFT=4$, but additional words are read as long as *ACKN* is asserted.

Figure 13: Request vs. End-of-Record, Strobe Condition of DSC=010

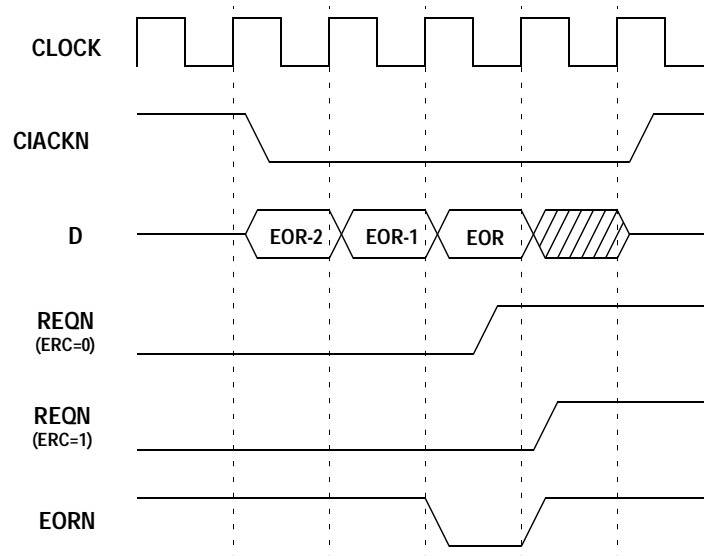

3.4.2 REQUEST DURING AN END-OF-RECORD

The request deasserts at an EOR in one of two ways. If *ERC* bit in *System Configuration 1* is zero, the request deasserts asynchronously during the clock where the EOR is strobed out of the FIFO. This leads to a long output delay for *REQN*, but may be necessary in some systems. For *DSC* values of 4 or 5, the request deasserts the first clock after the acknowledge pulse for the EOR. If *ERC* is set to one, then the request deasserts synchronously the clock after the EOR is strobed out. The minimum low time on the request in this case is one clock.

The request delay varies between the different strobe conditions. See Section 8.0 *AC Electrical Specifications* for further details.

3.4.3 REQUEST STATUS BITS

An external microprocessor can also read the value of each request using the *DIREQ* and *DOREQ* bits in the *Decompression Port Status* register. Please note the request status bits are active high while the pins are active low.

3.5 DATA FORMAT

The width of the *D* bus is selected with the *WIDE* bit in *System Configuration 0*. If *WIDE*=1, then *D* is a 32-bit bus. If *WIDE*=0, *D* is a 16-bit bus. If the bus is configured to be 16-bits wide (*WIDE*=0), all data transfers occur on *D*[15:0] and the upper 16 bits of the bus, *D*[31:16], should be terminated with Pullup resistors. If *WIDE*=0, the FIFO is sixteen words deep.

Since the compression algorithm is byte oriented, it is necessary for AHA3422 to know the ordering of the bytes within the word. The DECOMP BIG bit in *System Configuration 0* selects between big endian and little endian byte ordering. Little endian stores the first byte in the lower eight bits of a word (D[7:0]). Big endian stores the first byte in the uppermost eight bits of a word (D[31:24] for WIDE=1, D[15:8] for WIDE=0).

3.6 ODD BYTE HANDLING

All data transfers to or from the device are performed on the D bus on word boundaries. Since no provision is made for single byte transfers, occasionally words will contain pad bytes. Following is a description of when these pad bytes are necessary for each of the data interfaces.

3.6.1 INPUT, PAD BYTES AND ERROR CHECKING

The device recognizes the end of a record by the appearance of a special End-of-Record sequence in the data stream. Once this is seen, the remaining bytes in the current word are treated as pad bytes and discarded. The word following the end of the record is the beginning of the next record.

The *Decompression Record Length* (DRLEN) register can be used to provide error checking. The expected length of the decompressed record is programmed into the DRLEN register. The decompressor then counts down from the value in DRLEN to zero.

A DERR interrupt is issued if an EOR is not read out of the decompressor when the counter expires or if an EOR occurs before the counter expires (i.e., when the record lengths do not match). If the DERR interrupt is masked, use of the DRLEN register is optional.

When operating in pass-through mode, there is no End-of-Record codeword for the decompressor to see. In pass-through mode, the user must set the record length in the DRLEN register.

Figure 14: Timing Diagram, Video Output

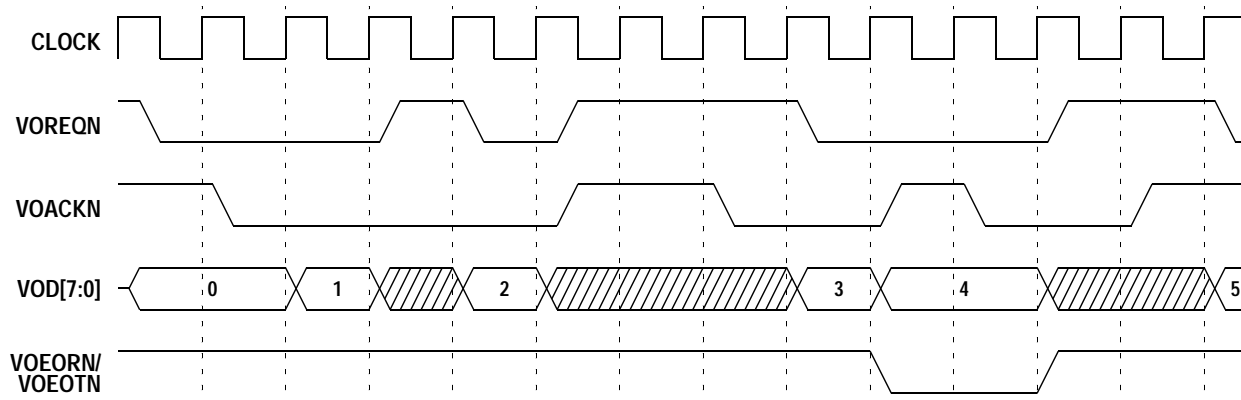

3.6.2 OUTPUT AND PAD BYTES

When the decompressor detects an End-of-Record codeword, it will add enough pad bytes of value 0x00 to complete the current word as defined by the WIDE bit in the *System Configuration 0* register. For example, if a record ends on a byte other than the last byte in a word, the final word contains 1, 2 or 3 pad bytes. This applies to the 32-bit data port only, not the VOD port. The VOD port never outputs pad bytes since it is 8-bits wide.

3.7 VIDEO INTERFACE

3.7.1 VIDEO OUTPUT

The video output port is enabled by the VDOE bit in the *System Configuration 1* register. The port uses VOREQN to indicate that the byte on VOD[7:0] is valid. An 8-bit word is read each clock when both VOREQN and VOACKN are sampled low on a rising edge of CLOCK. Pad bytes at an end of record are discarded by the video output port and do not appear on VOD[7:0]. When the byte on VOD[7:0] is the last byte in a record, the VOEORN signal goes low. Unlike a DMA transfer, there are no pad bytes after an End-of-Record.

VOEOTN operates similar to VOEORN. It flags the end of an output transfer of one or more decompressed records. VOEOTN is asserted when the End-of-Record is at the output of the DO FIFO and the decompression record count has decremented to zero.

The port requests whenever a valid byte is present on the output. The values in OET and OFT are all ignored. The decompression output FIFO is 16 bytes deep in this mode. The video output port can output up to one byte per clock. The DMA interface cannot access the decompression output FIFO when VDOE is set.

3.8 ALGORITHM

AHA3422 efficiently implements an algorithm optimized for bitonal images. For some comparison data refer to the AHA Application Note (ANDC13), *Compression Performance: StarLite™: ENCODEB2 on Bitonal Images*. A software emulation of the algorithm is available for evaluation.

3.9 DECOMPRESSION ENGINE

The decompression engine is enabled with the DCOMP bit in the *Decompression Control* register. When the engine is enabled, it takes data from the DI FIFO as it becomes available. This data is either decompressed by the engine or passed through unaltered. Pass-through mode is selected with the DPASS bit. DPASS may only be changed when DCOMP is set to zero and DEMP is set to one. The contents of the dictionary are preserved when DCOMP is changed. However, when DPASS is changed, the contents are lost. Consequently, AHA3422 cannot be changed from pass-through mode to decompression mode or vice versa without losing the contents of the dictionary.

The decompressor can be instructed to halt at the end of a record or an end of multiple-record transfer. If the DPOR bit is set, the decompressor stops taking data out of the DI FIFO immediately after the last byte of a record, and the DCOMP bit is cleared. If DPOT bit is set the decompressor halts at the end of the multiple-record transfer. The DEMP bit indicates the decompressor has emptied of all data. Decompression is restarted by setting the DCOMP bit. If DPOR or DPOT is set and data from a second record enters the FIFO immediately after the first record, bytes from the second record will have entered the decompressor prior to decoding the EOR. An implication of this is that bytes from the second record will remain in the decompressor and prevent DEMP from setting after all of the data from the first record has left the decompressor. This differs from operation of the compression engine. In either mode, a DEOR interrupt is generated when the last byte of a decompressed record is read out of the chip, and DEOT when the last byte of a transfer is read out of the chip.

The decompressor takes data from the decompression input FIFO at a maximum rate of 16 MBytes/sec. AHA3422 can maintain this data rate as long as the decompression input FIFO is not empty or the decompression output FIFO is not full.

Caveat: Changing the mode for the decompressor between records or multiple-record transfers must be done with the data of the following record or transfer held off until the DEOR status bit is true for the current record and the *Decompression Control* registers have been reprogrammed. This reprogramming can occur automatically with prearming.

3.10 PREARMING

Prearming is the ability to write certain registers that apply to the next record while the device is processing the current record. These registers may be prearmed for record boundaries. Prearming is automatic, meaning there is no way to disable it. If a prearmable register is written while the part is busy processing a record, at the end of the record the part takes its program from the register value last written. Decompression Control register has a corresponding prearm register.

The lower 3 bytes of *Decompression Length* register are prearmable. If the most significant byte of this register is written to, the counter is immediately loaded with the current 4 byte value. If the most significant byte is not written to the counter, the counter gets reloaded at the end of the current record.

3.11 INTERRUPTS

Five conditions are reported in the *Interrupt Status/Control 0* and *Status/Control 1* registers as individual bits. All interrupts are maskable by setting the corresponding bits in the *Interrupt Mask* register. A one in the *Interrupt Mask* register means the corresponding bit in the *Interrupt Status/Control* register is masked and does not affect the interrupt pin (INTRN). The INTRN pin is active whenever any unmasked interrupt bit is set to a one.

An End-of-Record interrupt is posted when a word containing an end-of-record is strobed out of the decompression output FIFO (DEOR). A DEOR interrupt is also reported if an end-of-record is read from the video output port. A decompression end of transfer interrupt will be posted if this is the last record of a transfer. End-of-Transfer interrupt (DEOT) is posted when an EOR occurs that causes the counter to decrement to zero.

Two FIFO error conditions are also reported. Overflowing the input FIFO generates a DIOF interrupt. An overflow can only be cleared by resetting the FIFO via the *Port Control* register.

Underflowing the output FIFO (reading when it is not ready) generates a DOUF. The underflow interrupt is cleared by writing a one to DOUF. In the event of an underflow, the FIFO must be reset.

3.12 DUPLEX PRINTING

Duplex Printing is the ability to print on both sides of the page. AHA3422 supports this with endian control.

During decompression of this reversed page the BIG bit in this register must be programmed to the same value used when this page of data was compressed. Use of this feature has virtually no effect on the decompression ratio when compared to decompressing in forward order.

3.13 BLANK BANDS

Setting DBLANK in the *Decompression Control* register causes the next record output from the Decompressor to be comprised of a repeating 8-bit pattern defined by the *Pattern* register. DBLANK automatically clears at the end of the next record. This command bit may be prearmed by writing to the *Decompression Control Prearm* register. When programming the device to generate blank records the system must not send data to be decompressed until the device has reached the end of record for the blank record.

3.14 LOW POWER MODE

The device is a data-driven system. When no data transfers are taking place, only the clock and on-chip RAMs including the FIFOs require power. To reduce power consumption to its absolute minimum, the user can stop the clock when it is high. With the system clock stopped and at a high level, the current consumption is due to leakage. *Control* and *Status* registers are preserved in this mode. Reinitialization of *Control* registers are not necessary when switching from Low Power to Normal operating mode.

3.15 TEST MODE

In order to facilitate board level testing, the device provides the ability to tristate all outputs. When the TEST0 pin is high, all outputs of the chip are tristated. When TEST0 is low, the chip returns to normal operation.

4.0 REGISTER DESCRIPTIONS

The microprocessor configures, controls and monitors IC operation through the use of the registers defined in this section. The bits labeled “*res*” are reserved and must be set to zero when writing to registers unless otherwise noted.

Always program the control register (address 0x3F) with a value of 0x0E following power on and any hard reset. This should be done prior to accessing any other registers.

A summary of registers is listed below.

Table 5: Internal Registers

ADDRESS	R/W	DESCRIPTION	FUNCTION	DEFAULT AFTER RSTN	PREARM
0x00	R/W	System Configuration 0	Big Endian vs. Little Endian, 32-bit vs. 16-bit	Undefined	No
0x01	R/W	System Configuration 1	Data Strobe Condition, EOR Request Control, VDO Port Enable	0x00	No
0x02	R/W	Input FIFO Thresholds	Input FIFO Empty Threshold, Full Threshold	Undefined	No
0x03	R/W	Output FIFO Thresholds	Output FIFO Empty Threshold, Full Threshold	Undefined	No
0x04	R	Reserved	Reserved	Undefined	
0x05	R	Decompression Ports Status	FIFO Status, Request Status, EOR Status	Undefined	No
0x06	R/W	Port Control 1	Reset Individual FIFOs	0x0F	No
0x07	R/W	Interrupt Status/Control 0	EOR, Overflow, Underflow	0x00	No
0x09	R/W	Interrupt Mask 0	Interrupt Mask bits	0xFF	No
0x0A	R	Version	Die Version Number	0x21	No
0x0C	R/W	Decompression Record Length 0	Bytes Remaining, Byte 0	0xFF	Yes
0x0D	R/W	Decompression Record Length 1	Bytes Remaining, Byte 1	0xFF	Yes
0x0E	R/W	Decompression Record Length 2	Bytes Remaining, Byte 2	0xFF	Yes
0x0F	R/W	Decompression Record Length 3	Bytes Remaining, Byte 3	0xFF	No
0x10	R	Reserved	Reserved	Undefined	
0x11	R	Reserved	Reserved	Undefined	
0x12	R	Reserved	Reserved	Undefined	
0x13	R	Reserved	Reserved	Undefined	
0x14	R	Reserved	Reserved	0x04	
0x15	R	Reserved	Reserved	0x00	
0x16	R	Reserved	Reserved	Undefined	
0x17	R	Reserved	Reserved	Undefined	
0x18	R/W	Decompression Control	Pause on Record Boundaries, Enable Decompression Engine, Decompression Engine Empty Status, Dictionary Reset, Enable Pass-Through Mode, Pause End-of-Transfer, Generate Blank Record, Enable Prearm	0x04	Yes

<i>ADDRESS</i>	<i>R/W</i>	<i>DESCRIPTION</i>	<i>FUNCTION</i>	<i>DEFAULT AFTER RSTN</i>	<i>PREARM</i>
0x1A	R/W	Decompression Reserved 1	Reserved	0x00	No
0x1C	R/W	Decompression Line Length 0	Line Length Register Lower 8 bits	Undefined	No
0x1D	R/W	Decompression Line Length 1	Line Length Register Upper 3 bits	Undefined	No
0x20	R	Reserved	Reserved	FF	
0x21	R	Reserved	Reserved	FF	
0x27	R/W	Interrupt Status/Control 1	Decompression EOT Interrupt	0x00	No
0x29	R/W	Interrupt Mask 1	Interrupt Mask bit for DEOT	0xFF	No
0x2C	R/W	Decompression Record Count 0	Decompressor number of records in a transfer	0xFF	No
0x2D	R/W	Decompression Record Count 1	Decompressor number of records in a transfer	0xFF	No
0x30	R	Reserved	Reserved	0x00	
0x31	R	Reserved	Reserved	0x00	
0x32	R	Reserved	Reserved	0x00	
0x33	R	Reserved	Reserved	0x00	
0x34	R	Reserved	Reserved	0x00	
0x35	R/W	Pattern	8-bit pattern for blank record generation	Undefined	No
0x38	R/W	Decompression Control Prearm	Prearm Register for Decompression Control	0x00	No
0x3A	R/W	Decompression Reserved 2	Reserved	0x00	No
0x3F	R/W	Control	Program to 0x0E	0x0F	No

4.1 SYSTEM CONFIGURATION 0, ADDRESS 0x00 - READ/WRITE

Address	<i>bit7</i>	<i>bit6</i>	<i>bit5</i>	<i>bit4</i>	<i>bit3</i>	<i>bit2</i>	<i>bit1</i>	<i>bit0</i>
0x00	<i>res</i>	WIDE	<i>res</i>				BIG	<i>res</i>

After reset, its contents are undefined. It must be written before any input or output data movement may be performed. After changing this register, reset FIFOs via the *Port Control* register.

BIG- Selects between little or big endian byte order for the decompressor. See table.

res - Bits must always be written with zeros.

WIDE - Selects between 32 and 16-bit D buses.

<i>COMP BIG or DECOMP BIG</i>	<i>WIDE</i>	<i>DESCRIPTION</i>				
0	0	Little Endian data order	16-bit words			
			D[15:8]	D[7:0]		
			Byte 1	Byte 0		
0	1	Little Endian data order	32-bit words			
			D[31:24]	D[23:16]	D[15:8]	D[7:0]
			Byte 3	Byte 2	Byte 1	Byte 0
1	0	Big Endian data order	16-bit words			
			D[15:8]	D[7:0]		
			Byte 0	Byte 1		
1	1	Big Endian data order	32-bit words			
			D[31:24]	D[23:16]	D[15:8]	D[7:0]
			Byte 0	Byte 1	Byte 2	Byte 3

4.2 SYSTEM CONFIGURATION 1, ADDRESS 0x01 - READ/WRITE

Address	<i>bit7</i>	<i>bit6</i>	<i>bit5</i>	<i>bit4</i>	<i>bit3</i>	<i>bit2</i>	<i>bit1</i>	<i>bit0</i>
0x01	<i>res</i>		VDOE	ERC	<i>res</i>	DSC[2:0]		

This register is cleared by reset.

DSC[2:0] - Data Strobe Condition. Control the condition used to strobe data into and out of the data ports on the D bus. Table 4 shows the programming for the strobe condition for various DMA modes.

res - Bits must always be written with zeros.

ERC - EOR Request Control. Determines when DOREQN deasserts at an End-of-Record. If ERC=0, then the request deasserts asynchronously during the clock when an EOR is strobed out. If ERC=1, then the request deasserts synchronously the clock after an EOR is strobed out. See Figure 17 through Figure 20.

VDOE - VDO Port Enable. When this bit is set, the data from the decompression output FIFO goes to the VDO port. When the bit is clear, the decompressed data is read by DMA on the D bus.

4.3 INPUT FIFO THRESHOLDS, ADDRESS 0x02 - READ/WRITE

Address	<i>bit7</i>	<i>bit6</i>	<i>bit5</i>	<i>bit4</i>	<i>bit3</i>	<i>bit2</i>	<i>bit1</i>	<i>bit0</i>
0x02	IFT[3:0]				IET[3:0]			

After reset, its contents are undefined. It must be written before any input or output data movement may be performed.

IET[3:0] - Empty threshold for the input FIFO. If the number of words in the input FIFO (DI) is less than or equal to this number, the request for that channel is asserted.

IFT[3:0] - Full threshold for the input FIFO. If the number of words in the input FIFO (DI) is greater than or equal to this number, the request for the channel is deasserted.

4.4 OUTPUT FIFO THRESHOLDS, ADDRESS 0x03 - READ/WRITE

Address	<i>bit7</i>	<i>bit6</i>	<i>bit5</i>	<i>bit4</i>	<i>bit3</i>	<i>bit2</i>	<i>bit1</i>	<i>bit0</i>
0x03	OFT[3:0]				OET[3:0]			

After reset, its contents are undefined. It must be written before any input or output data movement may be performed.

OET[3:0] - Empty threshold for the output FIFO. If the number of words in the output FIFO (DO) is less than or equal to this number, the request for the channel is deasserted (except in the case of an End-of-Record).

OFT[3:0] - Full threshold for the output FIFO. If the number of words in the output FIFO (DO) is greater than or equal to this number, the request for that channel is asserted.

4.5 DECOMPRESSION PORTS STATUS, ADDRESS 0x05 - READ ONLY

Address	<i>bit7</i>	<i>bit6</i>	<i>bit5</i>	<i>bit4</i>	<i>bit3</i>	<i>bit2</i>	<i>bit1</i>	<i>bit0</i>
0x05	DOEMP	DIEMP	<i>res</i>	DEOR	DOREQ	DOET	DIREQ	DIFT

This is a read only register. Writing to this register has no effect. After reset, its contents are undefined.

DIFT - Decompression input FIFO full threshold. This signal is active when the DI FIFO is at or above the programmed FIFO full threshold. After reset and the *Input FIFO Threshold* register has been written, this bit contains a zero.

DIREQ - Decompression input request signal state. Reports the current state for the DIREQN pin. Notice that this bit is active high while the pin is active low. Therefore, the value of this bit is always the inverse of the value of the signal. After reset this bit contains a zero.

DOET - Decompression output FIFO empty threshold. This bit is active when the DO FIFO is at or below the programmed FIFO empty threshold. After reset and the *Output FIFO Threshold* register has been written, this bit contains a one.

DOREQ - Decompression output request signal state. Reports the current state for the DOREQN pin. Notice that this bit is active high while the pin is active low. Therefore, the value of this bit is always the inverse of the value of the signal. After reset this bit contains a zero.

DEOR - Decompression output end of record. This bit is active when the output FIFO contains the End-of-Record code. After reset this bit contains a zero.

res - Bits must always be written with zeros.

- DIEMP - Decompression input empty. This bit is active when the DI FIFO is empty. After reset this bit contains a one.
- DOEMP - Decompression output empty. This bit is active when the DO FIFO is empty. After reset this bit contains a one.

4.6 PORT CONTROL, ADDRESS 0x06 - READ/WRITE

Address	<i>bit7</i>	<i>bit6</i>	<i>bit5</i>	<i>bit4</i>	<i>bit3</i>	<i>bit2</i>	<i>bit1</i>	<i>bit0</i>
0x06	<i>res</i>			DORST	DIRST	<i>res</i>		

This register is initialized to 0x0F after reset.

- DIRST - Decompression input reset. Setting this bit to a one resets the DI FIFO and clears the state machines in the decompression input port. The reset condition remains active until the microprocessor writes a zero to this bit.
- DORST - Decompression output reset. Setting this bit to a one resets the DO FIFO and clears the state machines in the decompression output port. The reset condition remains active until the microprocessor writes a zero to this bit.
- res* - Bits must always be written with zeros.

4.7 INTERRUPT STATUS/CONTROL 0, ADDRESS 0x07 - READ/WRITE

Address	<i>bit7</i>	<i>bit6</i>	<i>bit5</i>	<i>bit4</i>	<i>bit3</i>	<i>bit2</i>	<i>bit1</i>	<i>bit0</i>
0x07	DOUF	<i>res</i>	DIOF	<i>res</i>		DERR	DEOR	<i>res</i>

This register is initialized to 0x00 after reset.

- DEOR - Decompression End-of-Record interrupt. This bit is set when the last byte of a record is strobed out of the decompression DMA or video output port. The microprocessor must write a one to this bit to clear this interrupt.
- DERR - Decompression Error. This bit is set if an EOR leaves the decompressor before DRLEN has counted down to zero or if DRLEN counts to zero and the last byte is not an EOR. DERR is only active in decompression mode (DPASS=0). The microprocessor must write a one to this bit to clear this interrupt.
- res* - Bits must always be written with zeros.
- DIOF - Decompression Input FIFO Overflow. This interrupt is generated when a write to an already full DI FIFO is performed. Data written in this condition is lost. The only means of recovery from this error is to reset the FIFO with the DIRST bit. Resetting the FIFO causes this interrupt to clear. DIREQN is inactive while the interrupt is set.
- DOUF - Decompression Output FIFO underflow. This interrupt is generated when a read from an empty DO FIFO is performed. Once this interrupt is set, the DO FIFO must be reset with the DORST bit. The microprocessor must write a one to this bit to clear this interrupt. DOREQN is inactive while the interrupt is set.

4.8 INTERRUPT MASK 0, ADDRESS 0x09 - READ/WRITE

Address	<i>bit7</i>	<i>bit6</i>	<i>bit5</i>	<i>bit4</i>	<i>bit3</i>	<i>bit2</i>	<i>bit1</i>	<i>bit0</i>
0x09	DOUFM	<i>res</i>	DIOFM	<i>res</i>		DERRM	DEORM	<i>res</i>

This register is initialized to 0xFF after reset.

- DEORM - Decompression End-of-Record Interrupt Mask. When set to a one, prevents Decompression End-of-Record from causing INTRN to go active.
- DERRM - Decompression Error Mask. When set to a one, prevents a decompression error (DERR) from causing INTRN to go active.
- res* - Bits must always be written with zeros.
- DIOFM - Decompression Input FIFO Overflow Mask. When set to a one, prevents a decompression input FIFO overflow (DIOF) from causing INTRN to go active.
- DOUFM - Decompression Output FIFO Underflow Mask. When set to a one, prevents a decompression output FIFO underflow (DOUF) from causing INTRN to go active.

4.9 VERSION, ADDRESS 0x0A - READ ONLY

Address	<i>bit7</i>	<i>bit6</i>	<i>bit5</i>	<i>bit4</i>	<i>bit3</i>	<i>bit2</i>	<i>bit1</i>	<i>bit0</i>
0x0A	VERSION[7:0]							

VERSION[7:0] - Contains version number of the die.

4.10 DECOMPRESSION RECORD LENGTH, ADDRESS 0x0C, 0x0D, 0x0E, 0x0F - READ/WRITE

Address	<i>bit7</i>	<i>bit6</i>	<i>bit5</i>	<i>bit4</i>	<i>bit3</i>	<i>bit2</i>	<i>bit1</i>	<i>bit0</i>
0x0C	DRLEN[7:0]							
0x0D	DRLEN[15:8]							
0x0E	DRLEN[23:16]							
0x0F	DRLEN[31:24]							

These registers are initialized to 0xFF after reset.

- DRLEN[31:0]-Decompression Record Length. Contains the number of bytes in a decompressed record. These registers provide different functions depending on whether the decompressor is in pass-through or decompression mode. In decompression mode, the data itself contains EOR information and DRLEN is only used for error checking. DRLEN is decremented each time a byte leaves the decompressor.
- In decompression mode, a DERR interrupt is issued if an EOR is not read out of the decompressor when the counter expires or if an EOR occurs before the counter expires (i.e., when the record lengths do not match). If the DERR interrupt is masked, use of the DRLEN register is optional in decompression mode.
- In pass-through mode, DRLEN determines the size of records read out of the decompressor. The counter is decremented for each byte read into the decompressor.
- In either mode, the counter reloads when it reaches zero or when DRLEN[31:24] is written. Reading DRLEN returns the number of bytes left in the count. The lower three bytes of this register may be prearmed since the counter is automatically reloaded at the end of a record when the part is not programmed to pause on End-of-Record. The upper byte is not prearmable since writing to this byte triggers an immediate reload to the counter.

4.11 DECOMPRESSION CONTROL, ADDRESS 0x18 - READ/WRITE

Address	<i>bit7</i>	<i>bit6</i>	<i>bit5</i>	<i>bit4</i>	<i>bit3</i>	<i>bit2</i>	<i>bit1</i>	<i>bit0</i>
0x18	DPREARM	DBLANK	DPOT	DPASS	DDR	DEMP	DCOMP	DPOR

This register is initialized to 0x04 after reset. This register can be prearmed.

- DPOR** - Decompression Pause on record boundaries. When this bit is set to one, the decompressor stops taking data from the input FIFO once a record boundary is found. Upon finding the record boundary, DCOMP is cleared. This bit may only be changed when DCOMP is set to zero. After system reset or DDR, this bit is cleared.
- DCOMP** - Decompression. Setting this bit to a one enables the decompression engine (or pass-through mode if DPASS is set) to take data from the decompression input FIFO. If this bit is cleared, decompression stops. The bit is automatically cleared at the end of a record if DPOR is set. Decompression can be restarted without loss of data by setting DCOMP. After system reset or DDR, this bit is cleared.
- DEMP** - Decompression engine empty. This bit is set when the decompression engine is cleared of data. Writing to this bit has no effect. After system reset, this bit is set.
- DDR** - Decompression Dictionary Reset. Setting this bit immediately resets the decompressor including the decompression dictionary. The reset condition remains active until the microprocessor writes a zero to this bit.
- DPASS** - Decompression pass-through mode. While this bit is set, data is passed directly through the decompression engine without any effect on the data. This bit may only be changed when decompression is disabled (DCOMP=0) and the decompression engine is empty of data (DEMP=1). The pass-through operation is started by setting DCOMP. To stop the pass-through operation, DCOMP should be cleared (to pause operation) and then DPASS may be cleared.
- DPOT** - Decompression Pause on Transfer Boundaries. When this bit is set the decompressor stops taking data from the input FIFO once a decompression end of transfer boundary is found indicated by the Decompression Record Counter decrementing to zero.
- DBLANK** - Decompression Blank record. The data in the next record output from the decompressor is a repeating byte pattern using the 8-bit data defined in the PATTERN register. DBLANK automatically clears at the end of the record when the Decompression Record Count decrements to zero. When using DBLANK to generate a blank record the device must not contain data to be decompressed and the system must not send data to be decompressed for any future records until the part has reached the End-of-Record for the blank record. Also, the user must not set the DCOMP bit when the DBLANK bit is set.
- DPREARM** - Prearm Enable. When this bit is set, Decompression Control Prearm register is loaded into the Decompression Control register when the next end of record leaves the decompressor.

4.12 DECOMPRESSION RESERVED, ADDRESS 0x1A, 0x3A - READ/WRITE

Address	<i>bit7</i>	<i>bit6</i>	<i>bit5</i>	<i>bit4</i>	<i>bit3</i>	<i>bit2</i>	<i>bit1</i>	<i>bit0</i>
0x1A	<i>res</i>							
0x3A	<i>res</i>							

This register is used for production testing only. Initialized to 0x00 after reset.

4.13 DECOMPRESSION LINE LENGTH, ADDRESS 0x1C, 0x1D - READ/WRITE

Address	<i>bit7</i>	<i>bit6</i>	<i>bit5</i>	<i>bit4</i>	<i>bit3</i>	<i>bit2</i>	<i>bit1</i>	<i>bit0</i>
0x1C	LINE[7:0]							
0x1D	<i>res</i>					LINE[10:8]		

This register contains information necessary for the decompression operation. It must be set prior to any decompression operation. It should only be changed between records when DCOMP is cleared and DEMP is set. These registers are undefined after reset.

res - Bits must always be written with zeros.

LINE[10:0]-Line length. The number of bytes in the scan line. Minimum value is 16. For scan line lengths larger than the maximum allowed, set to 16.

4.14 INTERRUPT STATUS/CONTROL 1, ADDRESS 0x27 - READ/WRITE

Address	<i>bit7</i>	<i>bit6</i>	<i>bit5</i>	<i>bit4</i>	<i>bit3</i>	<i>bit2</i>	<i>bit1</i>	<i>bit0</i>
0x27	<i>res</i>						DEOT	<i>res</i>

This register is initialized to 0x00 after reset.

DEOT - Decompression End-of-Transfer Interrupt. This bit is set when a decompression end of transfer condition is reached indicated by the Decompression Record Counter counting down to zero. The microprocessor must write a one to this bit to clear this interrupt.

res - Bits must always be written with zeros.

4.15 INTERRUPT MASK 1, ADDRESS 0x29 - READ/WRITE

Address	<i>bit7</i>	<i>bit6</i>	<i>bit5</i>	<i>bit4</i>	<i>bit3</i>	<i>bit2</i>	<i>bit1</i>	<i>bit0</i>
0x29	<i>res</i>						DEOTM	<i>res</i>

This register is initialized to 0xFF after reset.

DEOTM - Decompression End-of-Transfer Interrupt Mask. When set to a one, prevents Decompression End-of-Transfer from causing INTRN to go active.

res - Bits must always be written with zeros.

res - Bits must always be written with zeros.

4.16 DECOMPRESSION RECORD COUNT, ADDRESS 0x2C, 0x2D - READ/WRITE

Address	<i>bit7</i>	<i>bit6</i>	<i>bit5</i>	<i>bit4</i>	<i>bit3</i>	<i>bit2</i>	<i>bit1</i>	<i>bit0</i>
0x2C	DRC[7:0]							
0x2D	DRC[15:8]							

These registers are initialized to 0xFFFF after reset.

DRC[15:0] -Decompression Record Count is the number of records in the current transfer. The internal record counter latches the value in this register when DRC[15:8] is written. The internal counter is decremented as the last byte of the record is decompressed. At the End-of-Transfer, the value in this register is reloaded into the internal record counter. Reading this register address returns the internal record counter value. Expiration of this counter causes the DEOT interrupt to be posted.

4.17 PATTERN, ADDRESS 0x35 - READ/WRITE

Address	<i>bit7</i>	<i>bit6</i>	<i>bit5</i>	<i>bit4</i>	<i>bit3</i>	<i>bit2</i>	<i>bit1</i>	<i>bit0</i>
0x35	PATTERN[7:0]							

This register is undefined after reset.

PATTERN[7:0]-Pattern is the 8-bit data used to generate blank bands or records. If DBLANK is set, the part outputs this register value repeatedly for the entire record (or band).

4.18 DECOMPRESSION CONTROL PREARM, ADDRESS 0x38 - READ/WRITE

Address	<i>bit7</i>	<i>bit6</i>	<i>bit5</i>	<i>bit4</i>	<i>bit3</i>	<i>bit2</i>	<i>bit1</i>	<i>bit0</i>
0x38	NDPREARM	NDBLANK	NDPOT	NDPASS	NDDR	res	NDCOMP	NDPOR

This register initializes to 0x00 after reset. This register is cleared when the prearm loads into the *Decompression Control* register, thus providing a method for the user to verify that the prearm loaded.

Note, the user must not change modes of operation between decompression, pass-through and blank when there is data in the decompressor. See Decompression Control register for bit descriptions. This register is the prearm register for the Decompression Control register.

res - Bits must always be written with zeros.

4.19 CONTROL, ADDRESS 0x3F - READ/WRITE

Address	<i>bit7</i>	<i>bit6</i>	<i>bit5</i>	<i>bit4</i>	<i>bit3</i>	<i>bit2</i>	<i>bit1</i>	<i>bit0</i>
0x3F	CONTROL CODE							

This register must be written with 0x0E before a decompression or pass-through operation begins. Default after reset is 0x0F.

5.0 SIGNAL DESCRIPTIONS

This section contains descriptions for all the pins. Each signal has a type code associated with it. The type codes are described in the following table.

<i>TYPE CODE</i>	<i>DESCRIPTION</i>
I	Input only pin
O	Output only pin
I/O	Input/Output pin
S	Synchronous signal
A	Asynchronous signal

5.1 MICROPROCESSOR INTERFACE

<i>MICROPROCESSOR INTERFACE</i>		
<i>SIGNAL</i>	<i>TYPE</i>	<i>DESCRIPTION</i>
PD[7:0]	I/O S	Processor Data. Data for all microprocessor reads and writes of registers within AHA3422 are performed on this bus. This bus may be tied to the Data bus, D[31:0], provided microprocessor accesses do not occur at the same time as DMA accesses.
PA[5:0]	I S	Processor Address Bus. Used to address internal registers within AHA3422.
CSN	I S	Chip Select. Selects AHA3422 as the source or destination of the current microprocessor bus cycle. CSN needs only be active for one clock cycle to start a microprocessor access.
DIR	I S	Direction. This signal indicates whether the access to the register specified by the PA bus is a read or a write. The polarity of this signal is programmed with the PROCMODE0 pin.
RDYN	O A,S	Ready. Indicates valid data is on the data bus during read operation and completion of write operation. Its operation depends on PROCMODE[1:0] settings.
INTRN	O S	Interrupt. The compression and decompression processes generate interrupts that are reported with this signal. INTRN is low whenever any non-masked bits are set in the <i>Interrupt Status/Control</i> register.
PROCMODE[1:0]	I S	Microprocessor Port Configuration Mode. Selects the polarity of the DIR pin and operation of the CSN pin. Refer to Section 2.1 <i>Microprocessor Interface</i> for details. (Figure 2 through Figure 5)

5.2 DATA INTERFACE

DATA INTERFACE		
SIGNAL	TYPE	DESCRIPTION
D[31:0]	I/O S	Data for all channels is transmitted on this bus. The ACKN is used to distinguish between the four channels. Data being written to AHA3422 is latched on the rising edge of CLOCK when the strobe condition is met. Data setup and hold times are relative to CLOCK. If the bus is configured to 16-bit transfers (WIDE=0), data is carried on D[15:0]. In this case, D[31:16] should be terminated with pullup resistors.
DRIVEN	I A	Drive Enable. Active low output driver enable. This input must be low in order to drive data onto D[31:0] in accordance with the current strobe condition.
SD	I S	Strobe Delay. Active high. Allows insertion of wait states for DMA access to the FIFOs. The strobe condition, as programmed in the DSC field of <i>System Configuration 1</i> , enables this signal and selects its polarity.
DIREQN	O S	Decompression Input Data Request, active low. When this signal is active, it indicates the ability of the DI port to accept data.
DIACKN	I S	Decompression Input Data Acknowledge. Active low decompression data input. When this signal is active, it indicates the data on D is for the decompression input port. Data on D is latched on the rising edge of CLOCK when the strobe condition is met.
DOREQN	O A, S	Decompression Output Data Request, active low. When this signal is active, it indicates the ability of the DO port to transmit data.
DOACKN	I S	Decompression Output Data Acknowledge. The definition of DOACKN varies with the data strobe condition in <i>System Configuration 1</i> . See Table 4.

5.3 VIDEO INTERFACE

VIDEO INTERFACE		
SIGNAL	TYPE	DESCRIPTION
VOREQN	O S	Video Output Request. Active low output indicating that the byte on VOD[7:0] is valid.
VOACKN	I S	Video Output Acknowledge. Active low input indicating that the external system is ready to read VOD[7:0].
VOD[7:0]	O S	Video Output Data. The value on this output bus is read when both VOREQN and VOACKN are low.
VOEORN	O S	Video Output End of Record is active low indicating the byte on VOD[7:0] contains the last byte in a record.
VOEOTN	O S	Video Output End of Transfer is active low indicating the byte on VOD[7:0] contains the last byte in a multi-record transfer.

5.4 SYSTEM CONTROL

<i>SYSTEM CONTROL</i>		
<i>SIGNAL</i>	<i>TYPE</i>	<i>DESCRIPTION</i>
CLOCK	I	System Clock. This signal is connected to the clock of the microprocessor. The Intel i960Cx calls this pin PCLK.
RSTN	I A	Power on Reset. Active low reset signal. The device must be reset before any DMA or microprocessor activity is attempted. RSTN should be a minimum of 10 CLOCK periods.
TEST0	I A	Board Test mode. When TEST is high, all outputs are tristated. When TEST is low, the chip performs normally.
TEST1	I A	Used for production tests. This input should always be tied low.

6.0 PINOUT

PIN	SIGNAL	PIN	SIGNAL	PIN	SIGNAL
1	VDD or VSS*	44	VSS	87	VOD[7]
2	VDD or VSS*	45	VSS	88	NC
3	VDD or VSS*	46	VDD	89	VDD
4	VDD or VSS*	47	CLOCK	90	VSS
5	VDD or VSS*	48	VSS	91	VOACKN
6	INTRN	49	VDD	92	TEST0
7	VSS	50	VDD	93	PA[0]
8	VDD	51	VSS	94	PA[1]
9	DRIVEN	52	VDD	95	PA[2]
10	SD	53	D[15]	96	PA[3]
11	DOACKN	54	D[16]	97	VDD
12	VDD	55	D[17]	98	PA[5]
13	DIACKN	56	D[18]	99	VSS
14	VDD	57	D[19]	100	PA[4]
15	VSS	58	D[20]	101	NC
16	VDD	59	D[21]	102	VOEOTN
17	DOREQN	60	D[22]	103	PROCMODE[1]
18	NC	61	D[23]	104	PROCMODE[0]
19	DIREQN	62	D[24]	105	CSN
20	NC	63	VSS	106	VDD
21	NC	64	VDD	107	VSS
22	D[0]	65	D[25]	108	DIR
23	VSS	66	D[26]	109	RSTN
24	VSS	67	D[27]	110	PD[7]
25	VDD	68	D[28]	111	PD[6]
26	VDD	69	D[29]	112	PD[5]
27	D[1]	70	D[30]	113	VDD
28	D[2]	71	VDD	114	VSS
29	D[3]	72	VDD	115	PD[4]
30	D[4]	73	VSS	116	PD[3]
31	D[5]	74	VSS	117	PD[2]
32	D[6]	75	D[31]	118	PD[1]
33	D[7]	76	VOREQN	119	PD[0]
34	D[8]	77	VOEORN	120	VDD
35	D[9]	78	VOD[0]	121	VSS
36	D[10]	79	VOD[1]	122	RDYN
37	D[11]	80	VOD[2]	123	VDD
38	VSS	81	VDD	124	VDD or VSS*
39	VDD	82	VSS	125	VDD or VSS*
40	D[12]	83	VOD[3]	126	VDD or VSS*
41	D[13]	84	VOD[4]	127	VDD
42	D[14]	85	VOD[5]	128	VSS
43	TEST1	86	VOD[6]		

*Note: the pins marked VDD or VSS can be connected to either VDD or VSS but should not be left unconnected.

Figure 15: Pinout

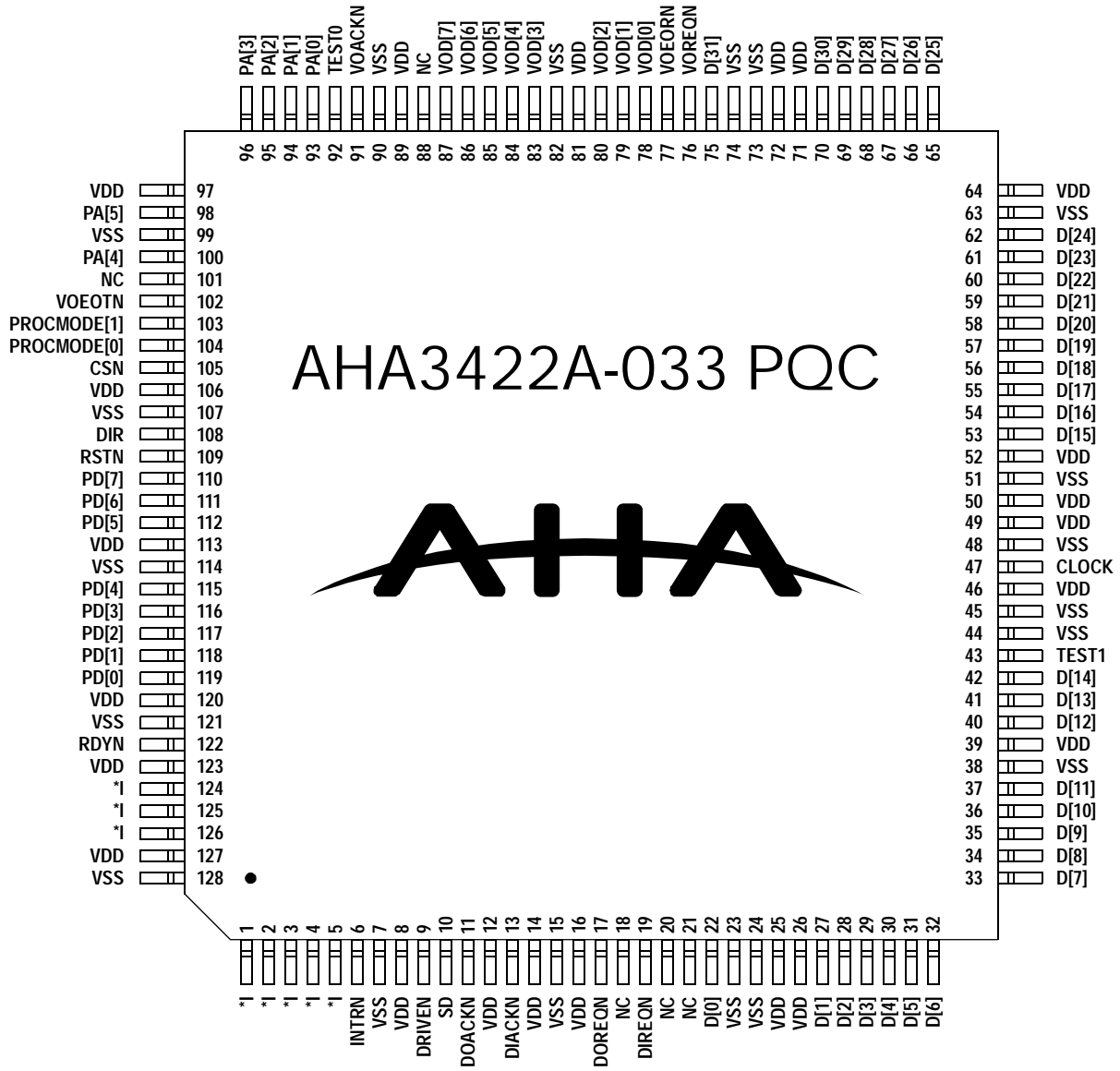

NC = No Connect
 *1 = Connect to VDD or VSS

7.0 DC ELECTRICAL SPECIFICATIONS

7.1 OPERATING CONDITIONS

OPERATING CONDITIONS					
SYMBOL	PARAMETER	MIN	MAX	UNITS	NOTES
Vdd	Supply voltage	4.75	5.25	V	
Idd	Supply current (active)		300	mA	4
Idd	Supply current (standby)		80	mA	1, 4
Idd	Supply current (low power)		1	mA	2, 4
Ta	Ambient temperature	0	70	°C	
Vil	Input low voltage: PROCMode[1:0], TEST0, TEST1 Other signals	Vss-0.5 Vss-0.5	0.3×Vdd 0.8	V	
Vih	Input high voltage: PROCMode[1:0], TEST0, TEST1 Other signals	0.7×Vdd 2.0	Vdd+0.5 Vdd+0.5	V	
Iil	Input leakage current	-10	10	μA	
Vol	Output low voltage (Iol=-4mA)		0.4	V	
Voh	Output high voltage (Ioh=4mA)	2.4		V	
Voh	Output high voltage (Ioh=100μA)	Vdd-0.8		V	
Iol	Output low current		4	mA	
Ioh	Output high current		-4	mA	
Ioz	Output leakage current	-10	10	μA	
Ioz	High impedance leakage current	-10	10	μA	
Cin	Input capacitance		5	pF	
Cout	Output capacitance		7	pF	
Cio	Input/Output capacitance		7	pF	
Comax	Maximum capacitance load for all signals (including self loading)		50	pF	3

Notes:

- 1) Dynamic current; no data transfers
- 2) Static current (clock high)
- 3) Timings referenced to this load
- 4) ILOAD = 0 mA

7.2 ABSOLUTE MAXIMUM STRESS RATINGS

ABSOLUTE MAXIMUM STRESS RATINGS					
SYMBOL	PARAMETER	MIN	MAX	UNITS	NOTES
Tstg	Storage temperature	-50	150	°C	
Vdd	Supply voltage	-0.5	7	V	
Vin	Input voltage	Vss-0.5	Vdd+0.5	V	

8.0 AC ELECTRICAL SPECIFICATIONS

Notes:

- 1) Production test condition is 50 pF. Output delay is decreased 2 ns with 25 pF load guaranteed by design or characterization.
- 2) All timings are referenced to 1.4 volts.

Figure 16: Data Interface Timing

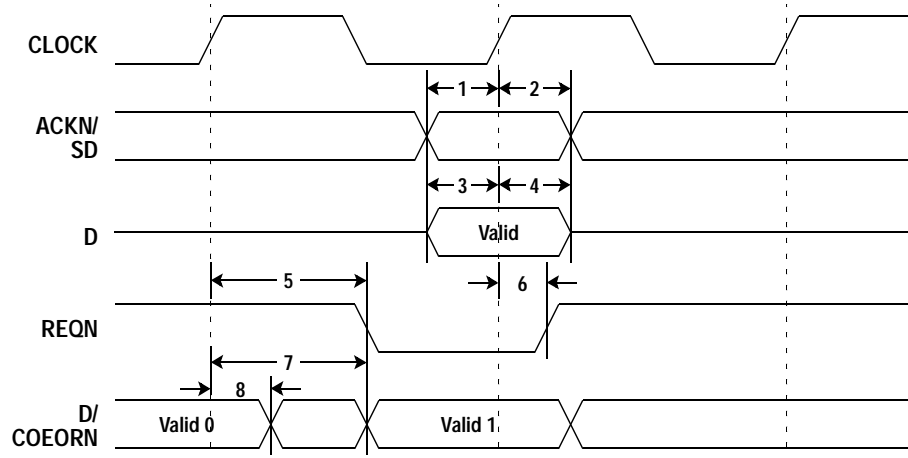

Table 6: Data Port Timing Requirements

NUMBER	PARAMETER	MIN	MAX	UNITS
1	DIACKN, DOACKN and SD setup time	8		ns
2	DIACKN, DOACKN and SD hold time	2		ns
3	D-bus input setup time	8		ns
4	D-bus input hold time	2		ns
5	REQN delay (non-EOR case)		18	ns
6	REQN hold (non-EOR case)	2		ns

Figure 17: Request Deasserts at EOR, Strobe Condition of DSC=0-3, 6-15; ERC=0

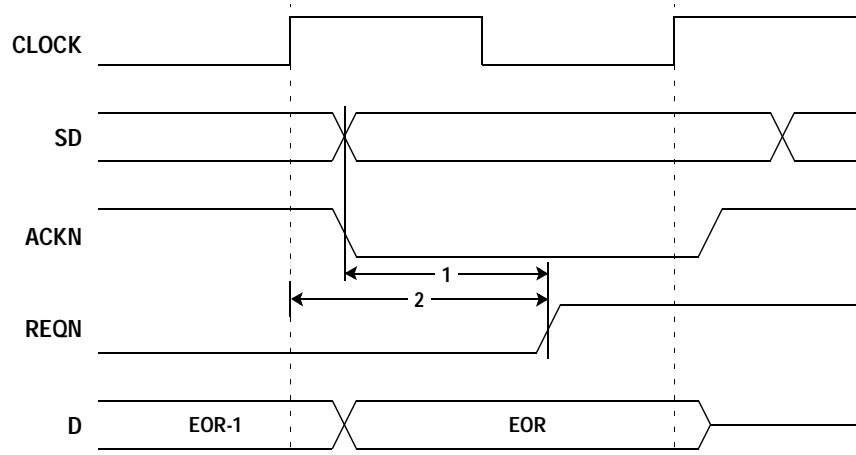

Figure 18: Request Deasserts at EOR, Strobe Condition of DSC=0-3, 6-15; ERC=1

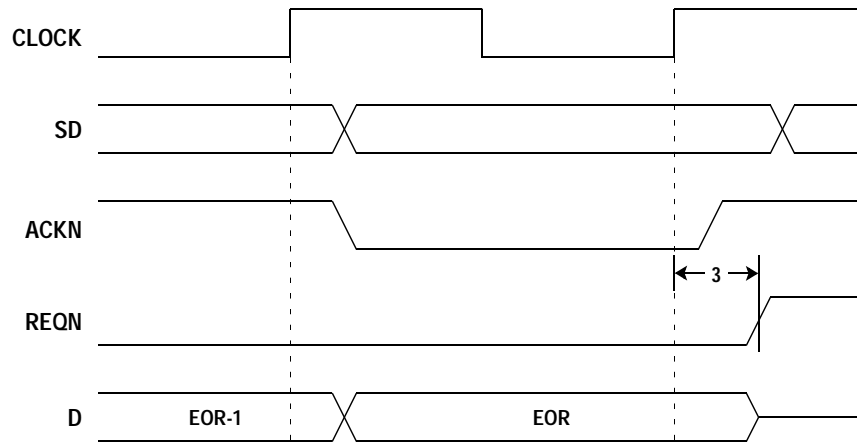

Figure 19: Request Deasserts at EOR, Strobe Condition of DSC=4 or 5; ERC=0

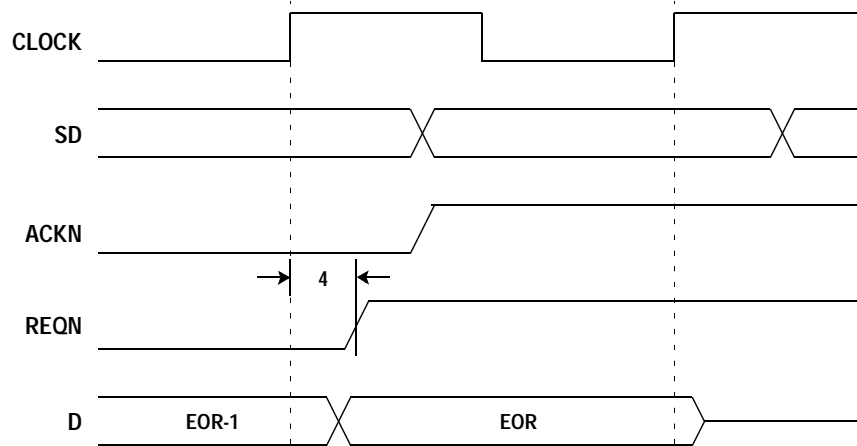

Figure 20: Request Deasserts at EOR, Strobe Condition of DSC=4 or 5; ERC=1

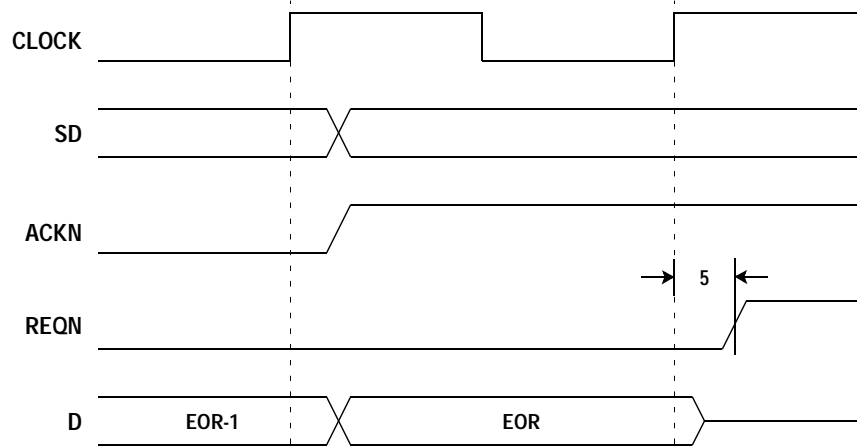

Table 7: Request vs. EOR Timing

NUMBER	PARAMETER	MIN	MAX	UNITS
1	ACKN, SD to REQN ERC=0		16	ns
2	CLOCK to REQN ERC=0		16	ns
3	CLOCK to REQN DSC=0-3, 6, 7; ERC=1		16	ns
4	CLOCK to REQN DSC=4, 5; ERC=0		16	ns
5	CLOCK to REQN DSC=4, 5; ERC=1		16	ns

Figure 21: Output Enable Timing

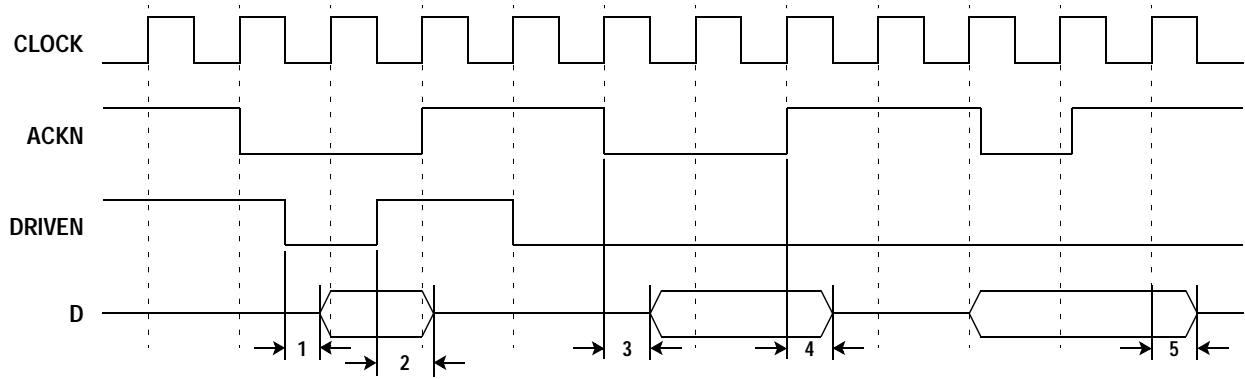

Table 8: Output Enable Timing Requirements

NUMBER	PARAMETER	MIN	MAX	UNITS
1	DRIVEN to D valid		15	ns
2	DRIVEN to D tristate		10	ns
3	Signal to D valid		15	ns
4	Signal to D tristate		10	ns
5	CLOCK to D tristate (DSC=100, 101)		15	ns

Figure 22: Video Output Port Timing

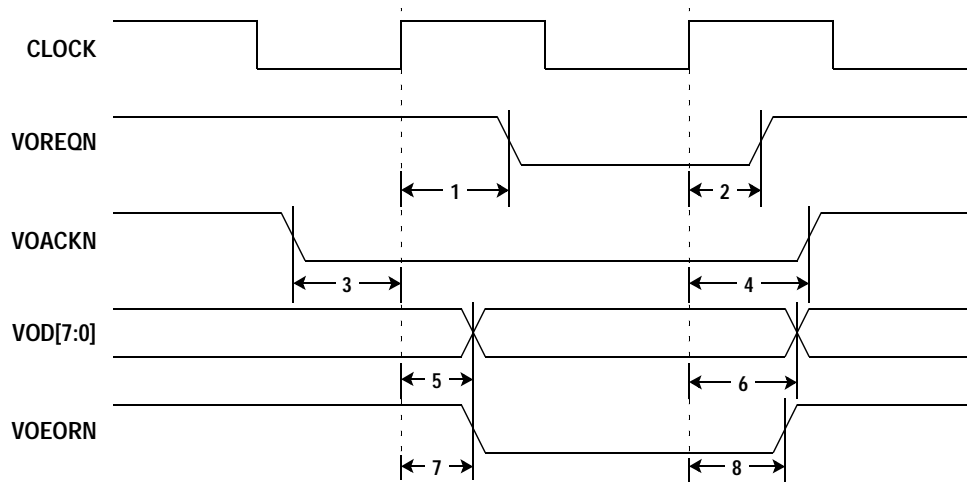

Table 9: Video Output Port Timing Requirements

NUMBER	PARAMETER	MIN	MAX	UNITS
1	VOREQN delay		16	ns
2	VOREQN hold	2		ns
3	VOACKN setup	8		ns
4	VOACKN hold	2		ns
5	VOD delay		16	ns
6	VOD hold	2		ns
7	VOEORN hold	2		ns
8	VOEORN delay		16	ns

Figure 23: Microprocessor Interface Timing (PROCMODE[1]=0)

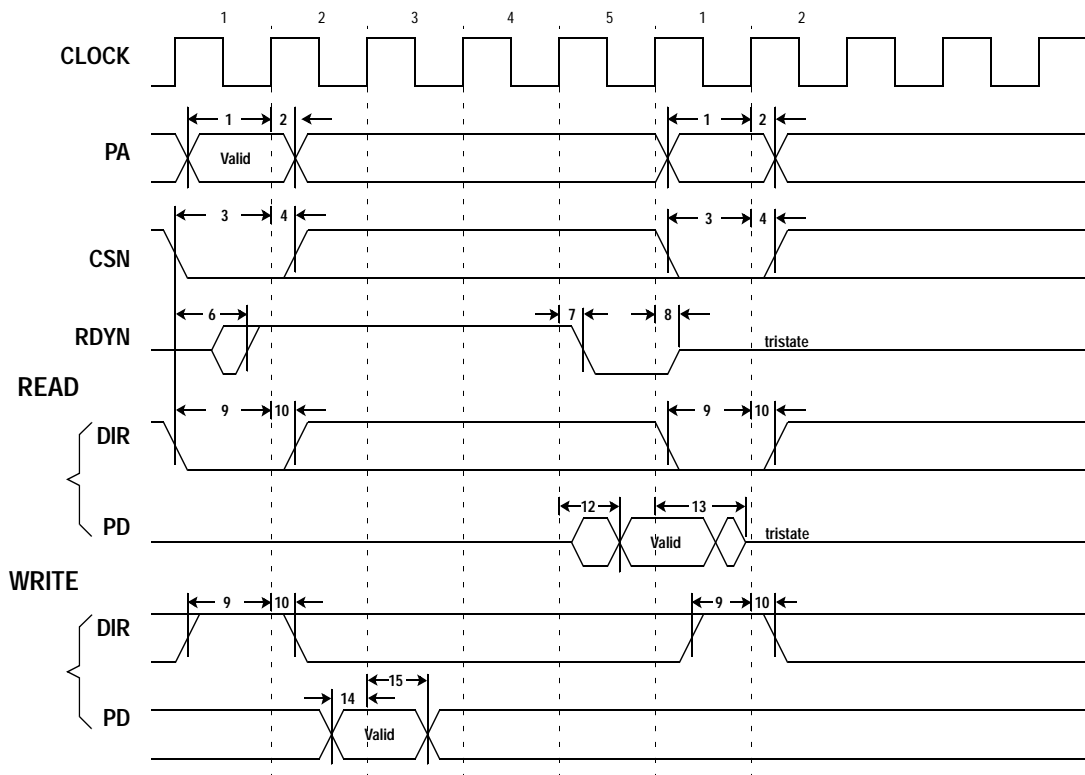

Figure 24: Microprocessor Interface Timing (PROCMODE[1]=1)

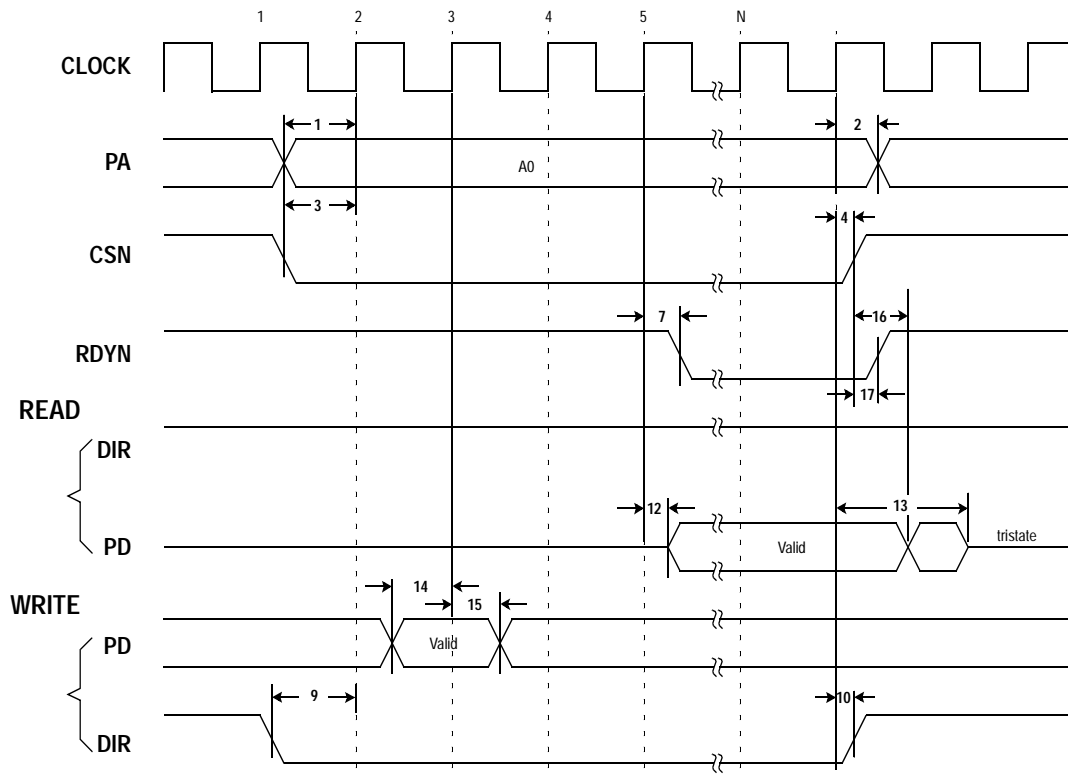

Table 10: Microprocessor Interface Timing Requirements

NUMBER	PARAMETER	MIN	MAX	UNITS
1	PA setup time	8		ns
2	PA hold time	2		ns
3	CSN setup time	8		ns
4	CSN hold time	2		ns
6	CSN to valid RDYN		15	ns
7	RDYN valid delay		16	ns
8	RDYN drive disable		10	ns
9	DIR setup time	8		ns
10	DIR hold time	2		ns
12	PD valid delay		16	ns
13	PD drive disable		12	ns
14	PD setup time	8		ns
15	PD hold time	2		ns
16	CSN high to PD tristate		10	ns
17	CSN high to RDYN high		15	ns

Figure 25: Interrupt Timing

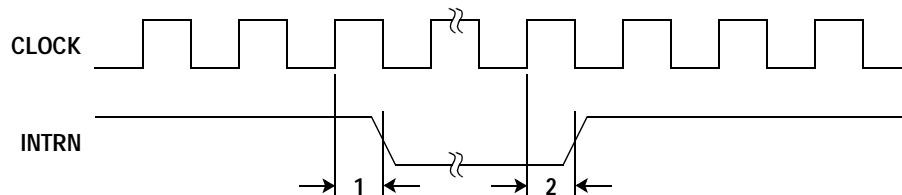

Table 11: Interrupt Timing Requirements

NUMBER	PARAMETER	MIN	MAX	UNITS
1	INTRN delay time		15	ns
2	INTRN hold time	2		ns

Figure 26: Clock Timing

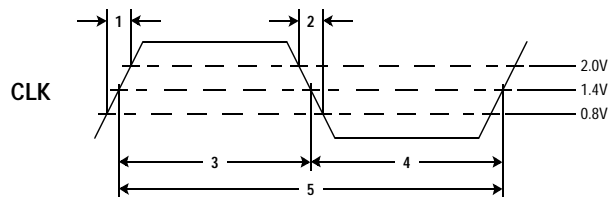

Table 12: Clock Timing Requirements

NUMBER	PARAMETER	MIN	MAX	UNITS
1	CLOCK rise time		2	ns
2	CLOCK fall time		2	ns
3	CLOCK high time	12		ns
4	CLOCK low time	12		ns
5	CLOCK period	30		ns

Figure 27: Power On Reset Timing

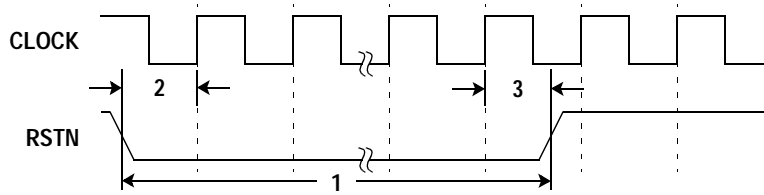

Table 13: Power On Reset Timing Requirements

NUMBER	PARAMETER	MIN	MAX	UNITS
1	RSTN low pulsewidth	10		clocks
2	RSTN setup to CLOCK rise	15		ns
3	RSTN hold time	2		ns

Notes:

- 1) RSTN signal can be asynchronous to the CLOCK signal. It is internally synchronized to the rising edge of CLOCK.

9.0 PACKAGE SPECIFICATIONS

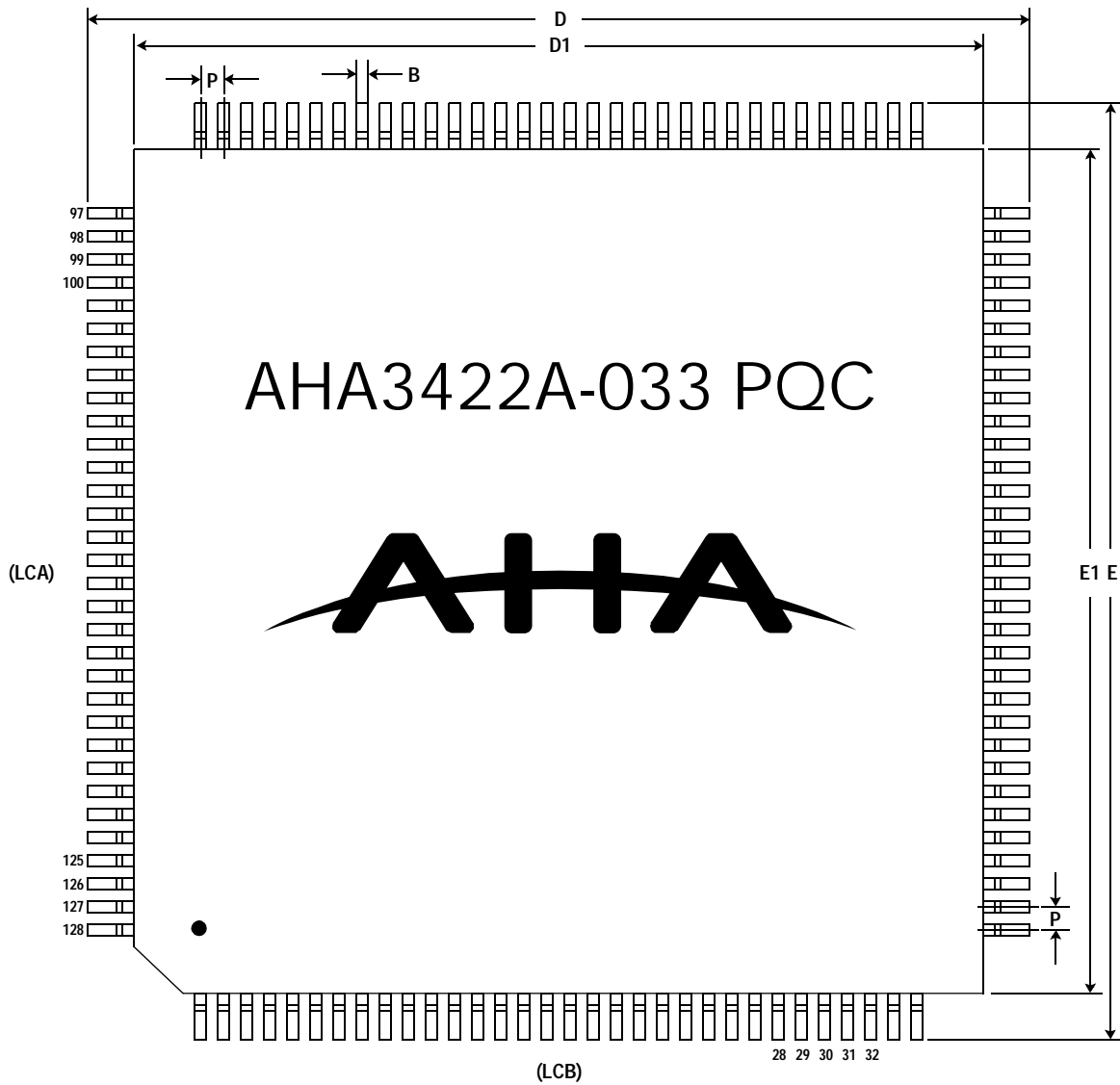
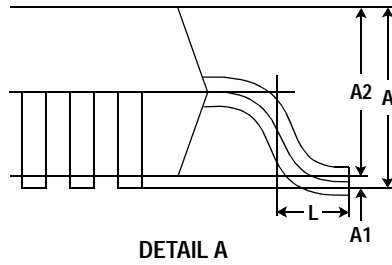
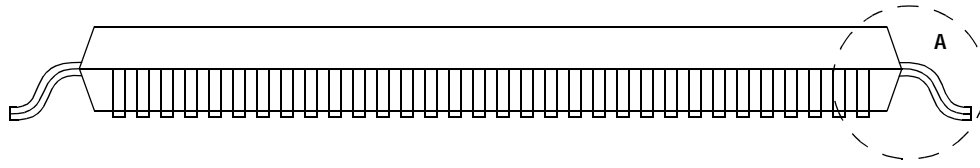

JEDEC outline is MO-108

PLASTIC QUAD FLAT PACK PACKAGE DIMENSIONS

SYMBOL	NUMBER OF PIN AND SPECIFICATION DIMENSION		
	128		
	SB		
	MIN	NOM	MAX
(LCA)	32		
(LCB)	32		
A		3.7	4.07
A1	0.25	0.33	
A2	3.2	3.37	3.6
D	30.95	31.2	31.45
D1	27.99	28	28.12
E	30.95	31.2	31.45
E1	27.99	28	28.12
L	0.73	0.88	1.03
P		0.8	
B	0.3	0.35	0.4

10.0 ORDERING INFORMATION**10.1 AVAILABLE PARTS**

PART NUMBER	DESCRIPTION
AHA3422A-033 PQC	16 MBytes/sec Lossless Decompressor IC

10.2 PART NUMBERING

AHA	3422	A-	033	P	Q	C
Manufacturer	Device Number	Revision Level	Speed Designation	Package Material	Package Type	Test Specification

Device Number:

3422

Revision Letter:

A

Package Material Codes:

P Plastic

Package Type Codes:

Q Quad Flat Pack

Test Specifications:

C Commercial 0°C to +70°C

11.0 RELATED TECHNICAL PUBLICATIONS

<i>DOCUMENT #</i>	<i>DESCRIPTION</i>
PS3410C	AHA Product Specification – AHA3410C StarLite™ 25 MBytes/sec Simultaneous Lossless Data Compression/Decompression Coprocessor IC
PS3411	AHA Product Specification – AHA3411 StarLite™ 33 MBytes/sec Simultaneous Compressor/Decompressor IC
PS3431	AHA Product Specification – AHA3431 StarLite™ 40 MBytes/sec Simultaneous Compressor/Decompressor IC, 3.3V
PB3410C	AHA Product Brief – AHA3410C StarLite™ 25 MBytes/sec Simultaneous Lossless Data Compression/Decompression Coprocessor IC
PB3411	AHA Product Brief – AHA3411 StarLite™ 33 MBytes/sec Simultaneous Compressor/Decompressor IC
PB3422	AHA Product Brief – AHA3422 StarLite™ 16 MBytes/sec Lossless Decompressor IC
PB3431	AHA Product Brief – AHA3431 StarLite™ 40 MBytes/sec Simultaneous Compressor/Decompressor IC, 3.3V
ABDC18	AHA Application Brief – AHA3410C, AHA3411 and AHA3431 Device Differences
ANDC12	AHA Application Note – AHA3410C StarLite™ Designer's Guide
ANDC13	AHA Application Note – Compression Performance on Bitonal Images
ANDC14	AHA Application Note – StarLite™ Evaluation Software
ANDC15	AHA Application Note – ENCODEB2 Compression Algorithm Description
ANDC16	AHA Application Note – Designer's Guide for StarLite™ Family Products: AHA3411, AHA3422 and AHA3431
ANDC17	AHA Application Note – StarLite™ Compression on Continuous Tone Images
GLGEN1	General Glossary of Terms
STARSW	StarLite™ Evaluation Software (Windows™)

APPENDIX A: ADDITIONAL TIMING DIAGRAMS FOR DMA MODE TRANSFERS

Figure A1: DMA Mode Timing for Single Word Writes, Strobe Condition of DSC=000

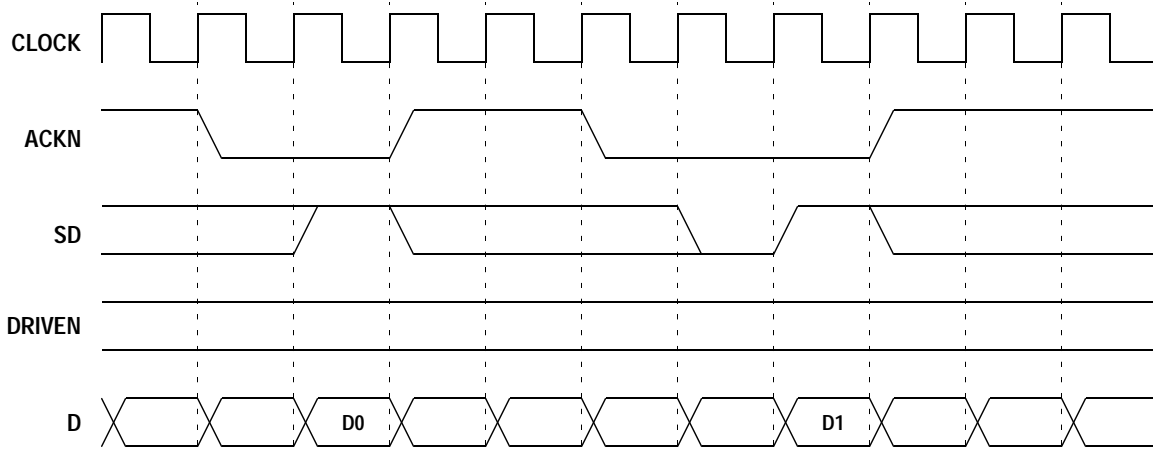

Figure A2: DMA Mode Timing for Single Word Reads, Strobe Condition of DSC=000

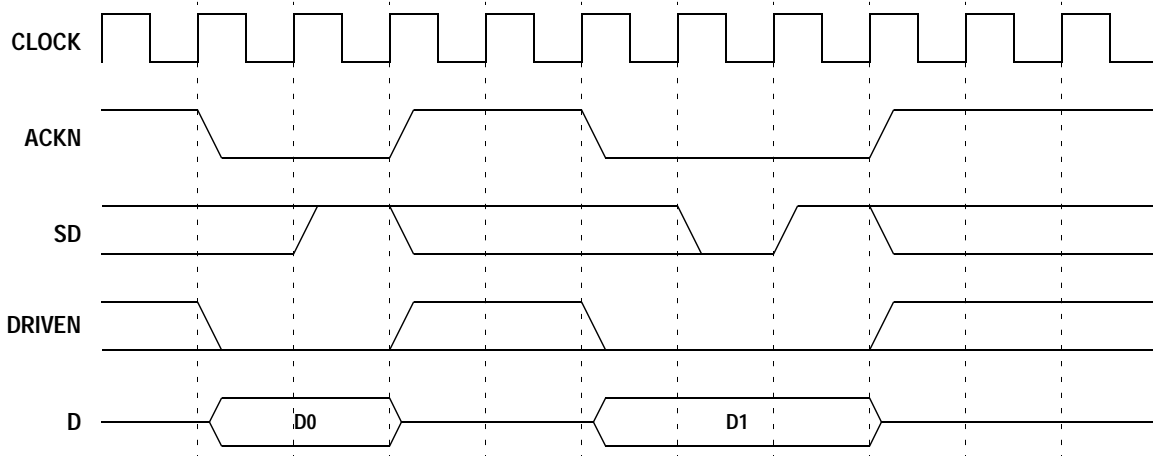

Figure A3: DMA Mode Timing for Four Word Burst Write, One Wait State, Strobe Condition of DSC=000

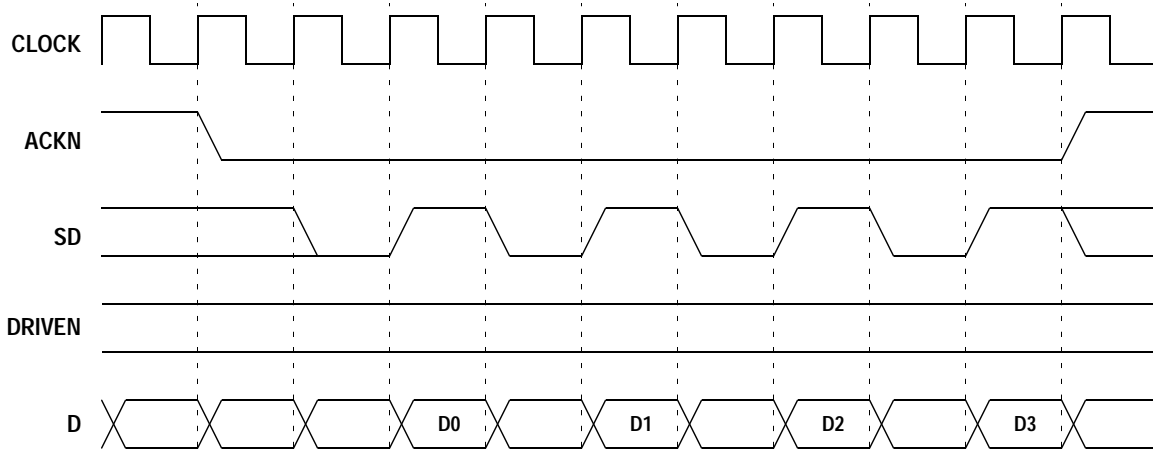

Figure A4: DMA Mode Timing for Four Word Burst Read, One Wait State, Strobe Condition of DSC=000

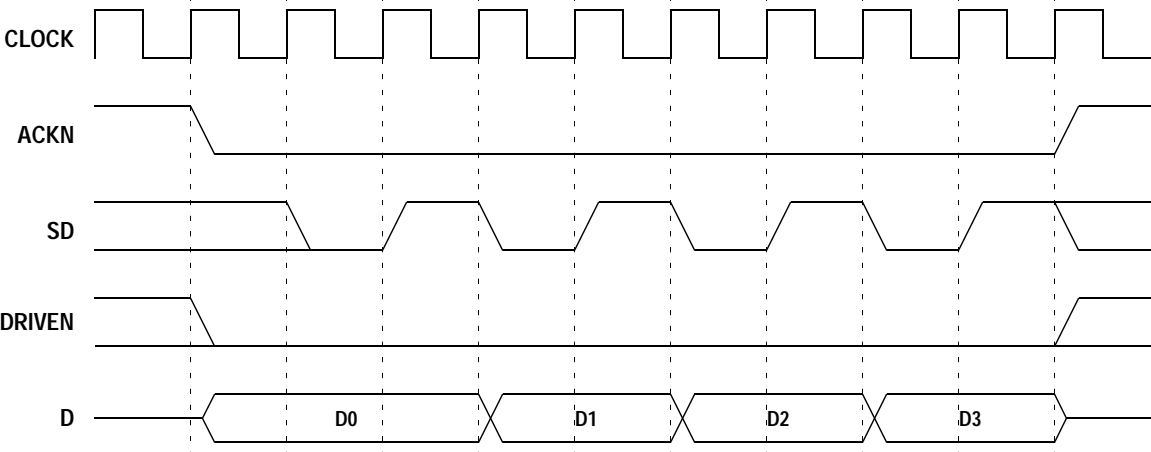

Figure A5: DMA Mode Timing for Eight Word Burst Write, Zero Wait State, Strobe Condition of DSC=000

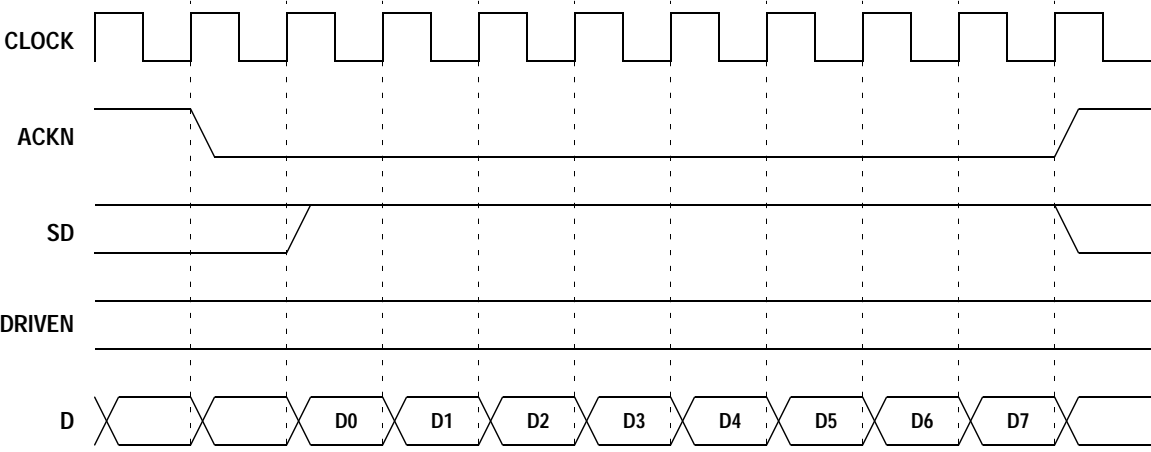

Figure A6: DMA Mode Timing for Eight Word Burst Read, Zero Wait State, Strobe Condition of DSC=000

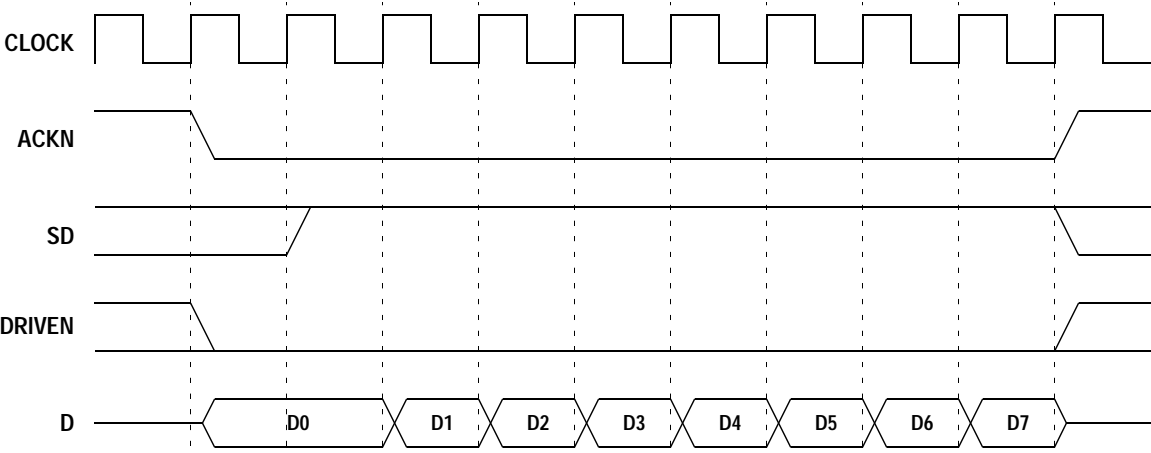

Figure A7: DMA Mode Timing for Single Word Writes, Strobe Condition of DSC=010

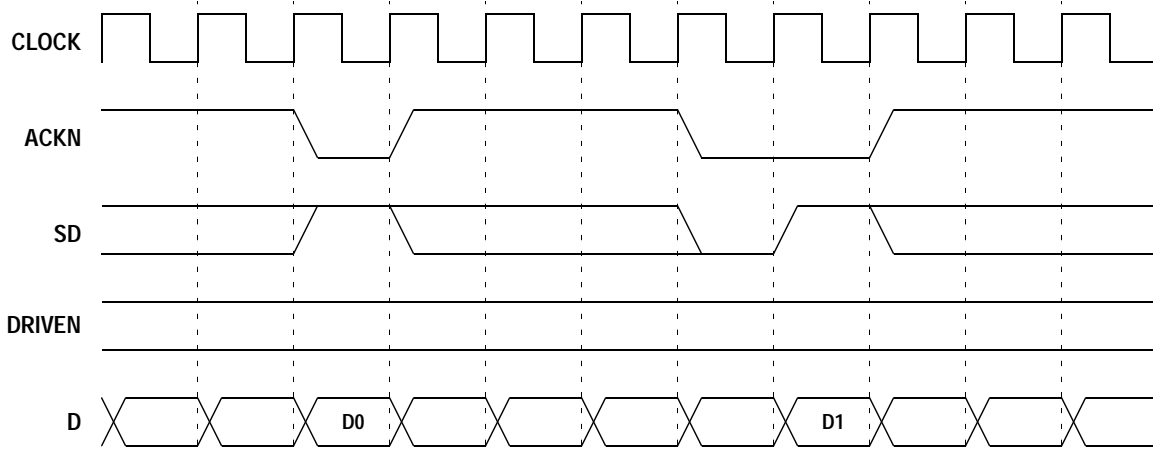

Figure A8: DMA Mode Timing for Single Word Reads, Strobe Condition of DSC=010

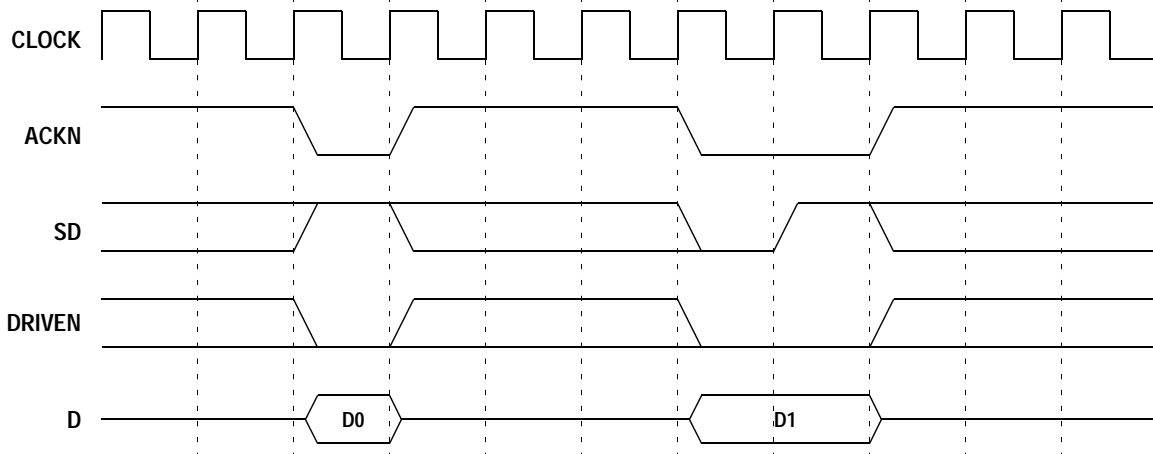

Figure A9: DMA Mode Timing for Four Word Burst Write, One Wait State, Strobe Condition of DSC=010

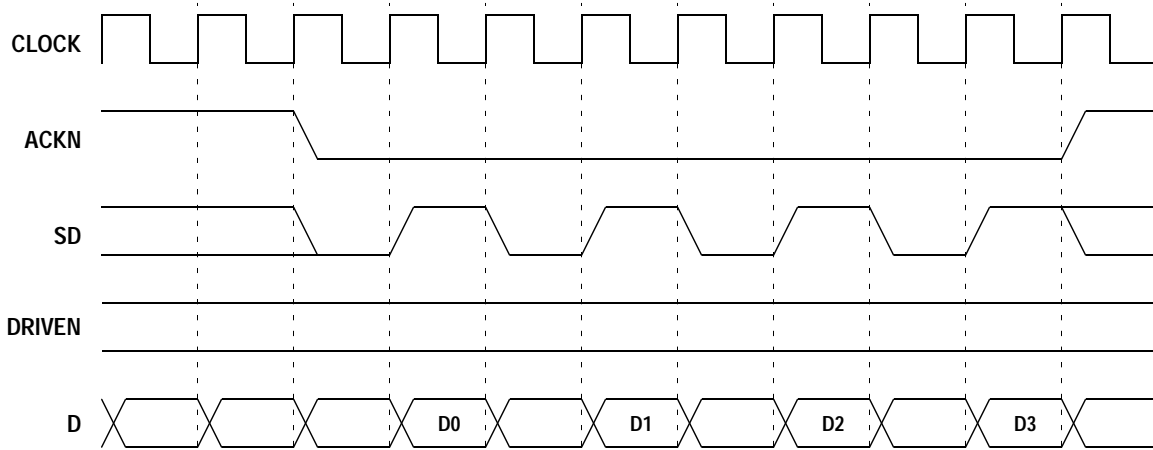

Figure A10: DMA Mode Timing for Four Word Burst Read, One Wait State, Strobe Condition of DSC=010

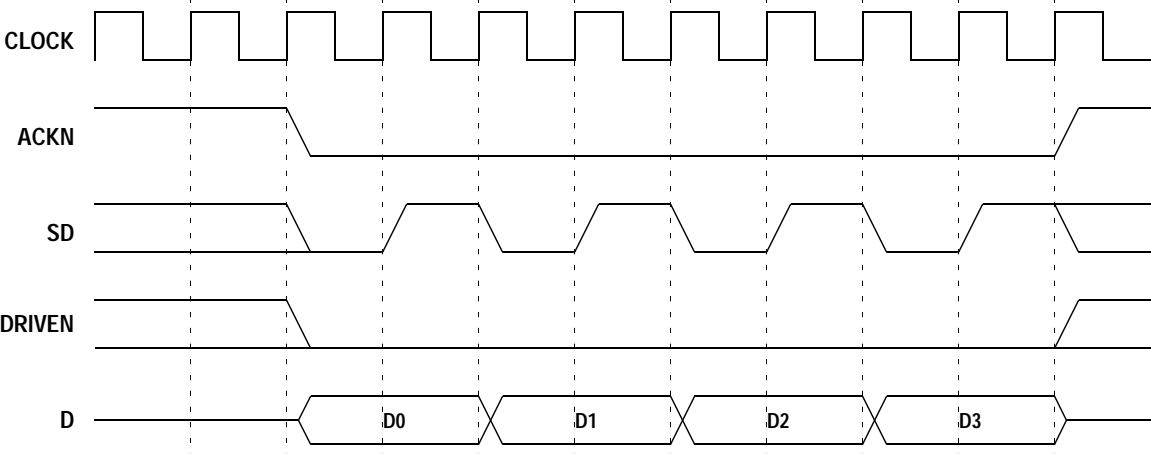

Figure A11: DMA Mode Timing for Eight Word Burst Write, Zero Wait State, Strobe Condition of DSC=010

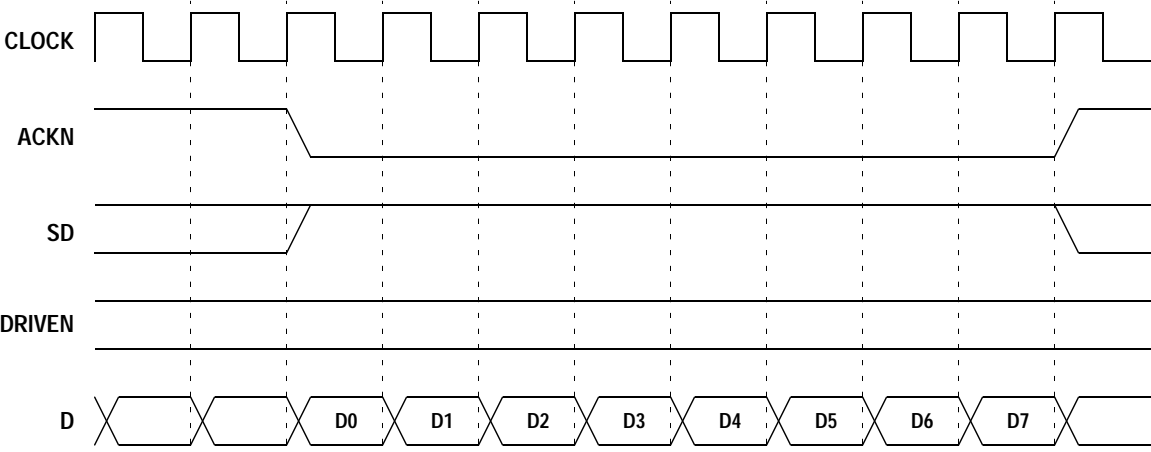

Figure A12: DMA Mode Timing for Eight Word Burst Read, Zero Wait State, Strobe Condition of DSC=010

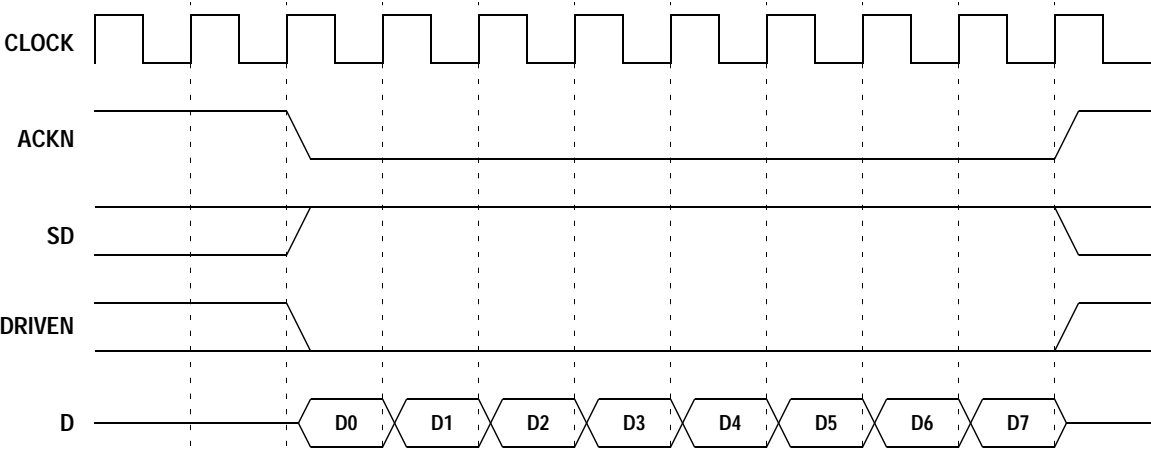

Figure A13: DMA Mode Timing for Single Word Writes, Strobe Condition of DSC=011

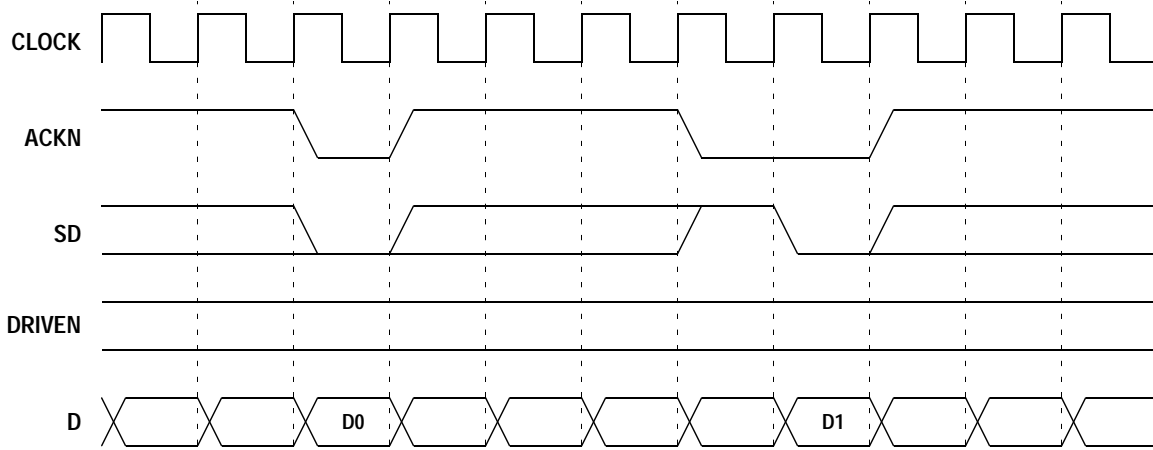

Figure A14: DMA Mode Timing for Single Word Reads, Strobe Condition of DSC=011

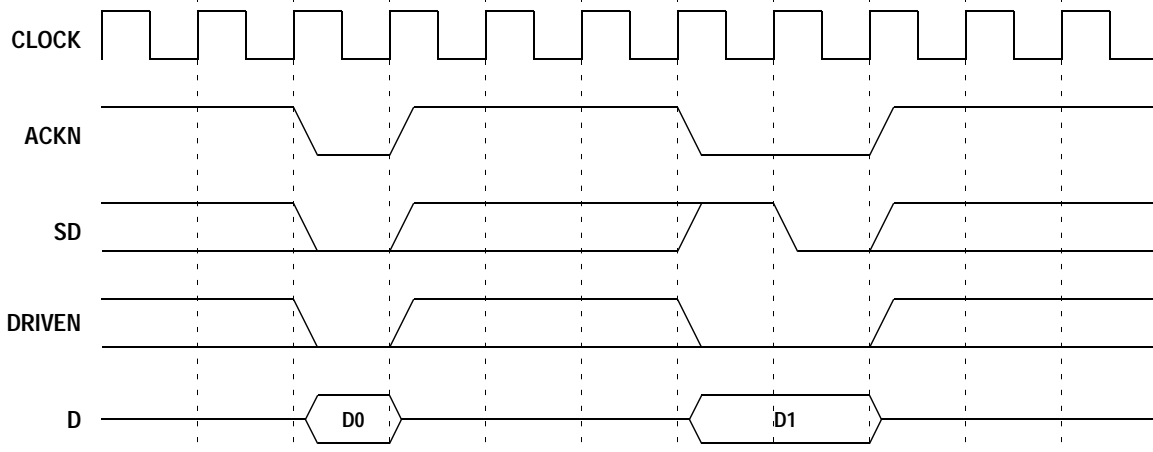

Figure A15: DMA Mode Timing for Four Word Burst Write, One Wait State, Strobe Condition of DSC=011

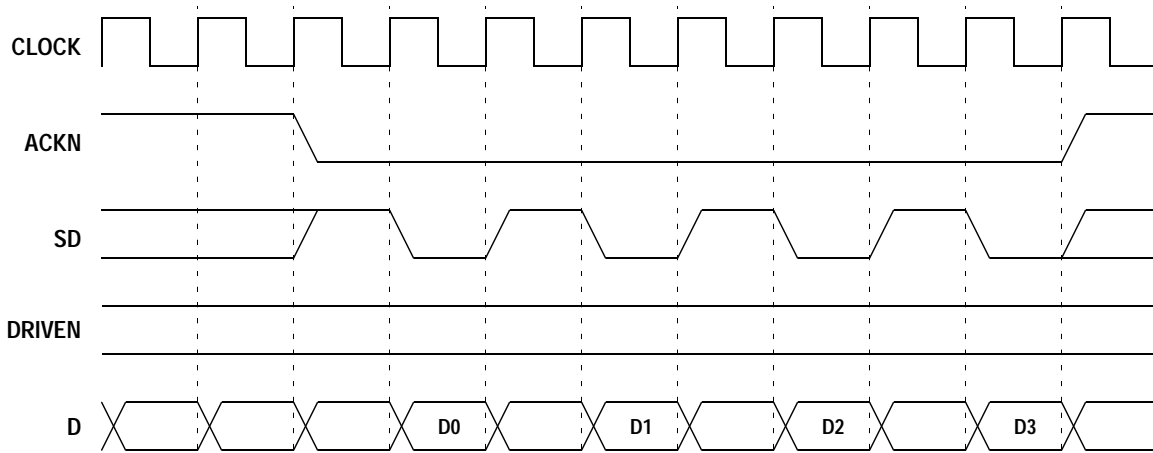

Figure A16: DMA Mode Timing for Four Word Burst Read, One Wait State, Strobe Condition of DSC=011

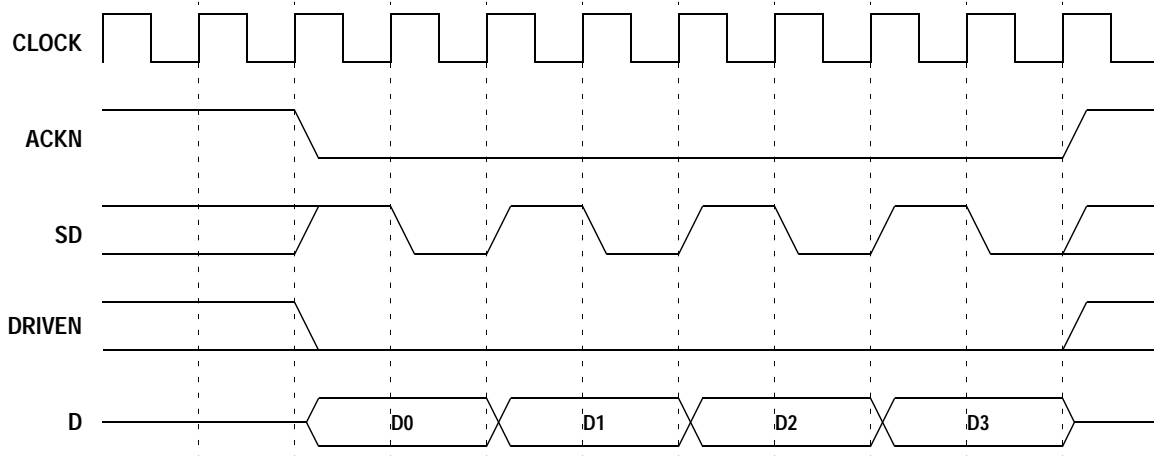

Figure A17: DMA Mode Timing for Eight Word Burst Write, Zero Wait State, Strobe Condition of DSC=011

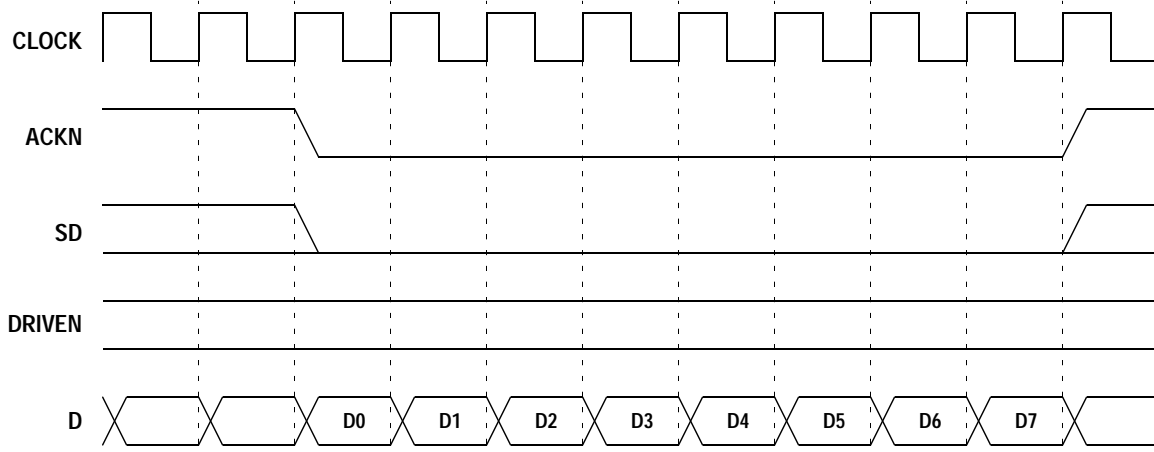

Figure A18: DMA Mode Timing for Eight Word Burst Read, Zero Wait State, Strobe Condition of DSC=011

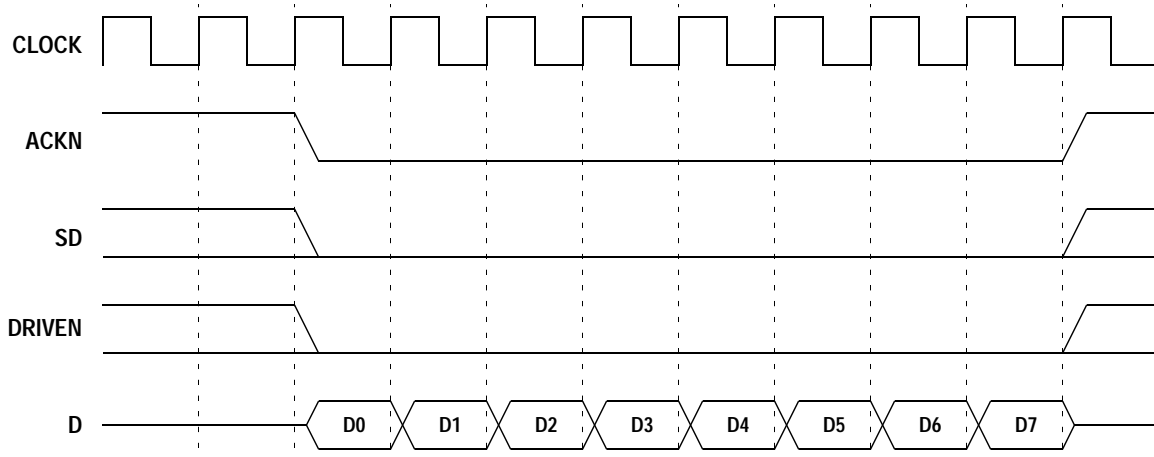

Figure A19: DMA Mode Timing for Single Word Writes, Strobe Condition of DSC=111

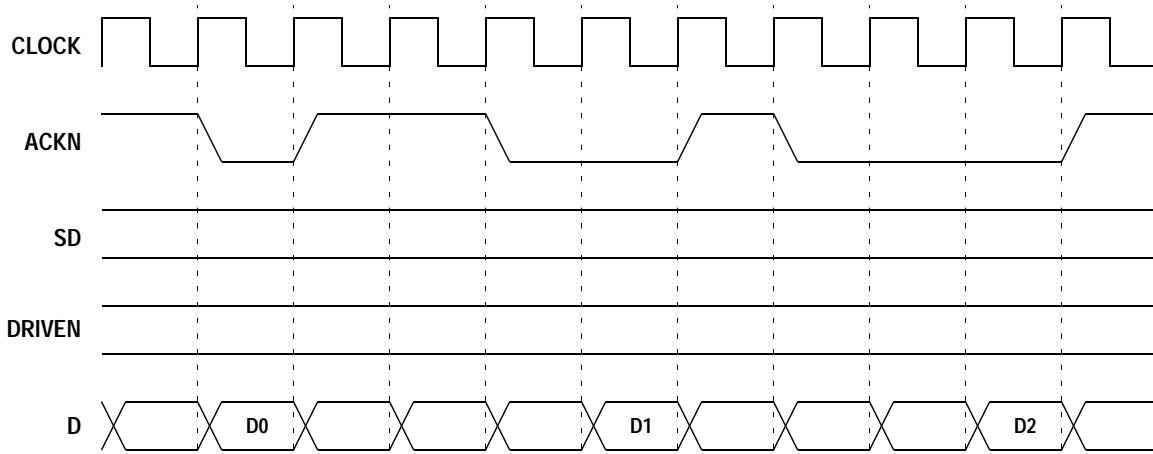
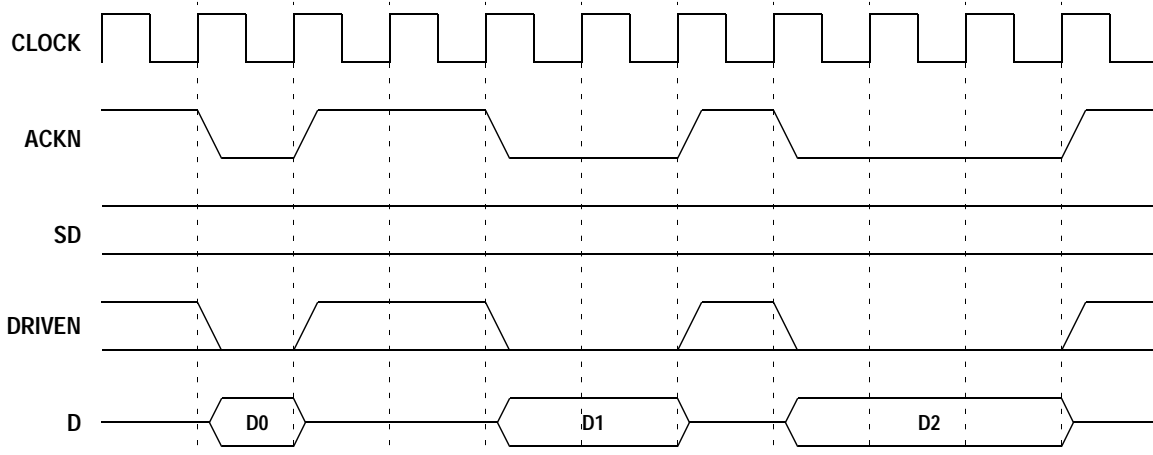

Figure A20: DMA Mode Timing for Single Word Reads, Strobe Condition of DSC=111



APPENDIX B: SEQUENTIAL REGISTER TABLE

<i>ADDRESS</i>	<i>DESCRIPTION</i>
00	System Configuration 0
01	System Configuration 1
02	Input FIFO Thresholds
03	Output FIFO Thresholds
04	Reserved
05	Decompression Ports Status
06	Port Control
07	Interrupt Status/Control 0
09	Interrupt Mask 0
0A	Version
0C	Decompression Record Length 0
0D	Decompression Record Length 1
0E	Decompression Record Length 2
0F	Decompression Record Length 3
10	Reserved
11	Reserved
12	Reserved
13	Reserved
14	Reserved
15	Reserved
16	Reserved
17	Reserved
18	Decompression Control
1A	Decompression Reserved 1
1C	Decompression Line Length 0
1D	Decompression Line Length 1
20	Reserved
21	Reserved
27	Interrupt Status/Control 1
29	Interrupt Mask 1
2C	Decompression Record Count 0
2D	Decompression Record Count 1
30	Reserved
31	Reserved
32	Reserved
33	Reserved
34	Reserved
35	Pattern
38	Decompression Control Prearm
3F	Control