

1A Low Dropout Positive Adjustable Regulator

FEATURES

- Dropout Voltage 1.3V at 1A Output Current.
- Fast Transient Response.
- Line Regulation typically at 0.015%.
- Load Regulation typically at 0.1%.
- Internal Thermal and Current Limiting.
- Adjustable Output Voltage or Fixed 2.85V, 3.3V, 5V.
- Standard 3-Pin Power Packages.

APPLICATIONS

- Post Regulator for Switching Supply.
- Active SCSI Termination.
- Battery Chargers.
- Constant-Current Regulators.
- Motherboard Clock Supplies.

DESCRIPTION

The AIC1117A is a low dropout three terminal regulator with 1A output current capability. The output voltage is adjustable with the use of a resistor divider or fixed 2.85V, 3.3V, 5V. Dropout is guaranteed at a maximum of 1.5V at maximum output current. Its low dropout voltage and fast transient response make it ideal for low voltage microprocessor applications. Internal current and thermal limiting provides protection against any overload condition that would create excessive junction temperatures.

TYPICAL APPLICATION CIRCUIT

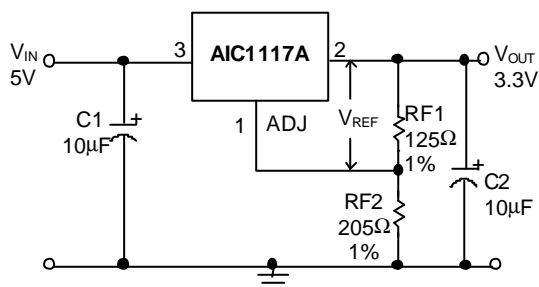

Adjustable Voltage Regulator

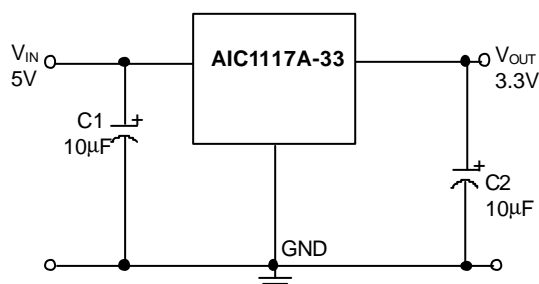

Fixed Voltage Regulator

$$V_{REF} = V_{OUT} - V_{ADJ} = 1.25V \text{ (typ.)}$$

$$V_{OUT} = V_{REF} \times (1 + RF2/RF1) + I_{ADJ} \times RF2$$

$$I_{ADJ} = 55\mu A \text{ (typ.)}$$

(1) C1 needed if device is far away from filter capacitors.

(2) C2 required for stability.

ORDERING INFORMATION

AIC1117A-~~XX~~CX

PACKAGING TYPE

E: TO-252

M: TO-263

T: TO-220

Y: SOT-223

DEFAULT: ADJ.

28: 2.85V

33: 3.3V

50: 5.0V

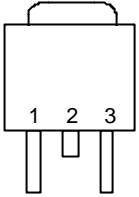
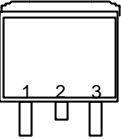
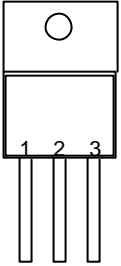
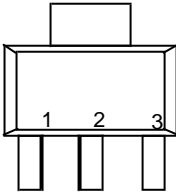
ORDER NUMBER	PIN CONFIGURATION
AIC1117ACE (TO-252)	FRONT VIEW 1: ADJ 2: VOUT (TAB) 3: VIN 
AIC1117ACM (TO-263)	FRONT VIEW 1: ADJ 2: VOUT (TAB) 3: VIN 
AIC1117ACT (TO-220)	FRONT VIEW 1: ADJ 2: VOUT (TAB) 3: VIN 
AIC1117ACY (SOT-223)	FRONT VIEW 1: ADJ 2: VOUT (TAB) 3: VIN 

■ ABSOLUTE MAXIMUM RATINGS

VIN pin to ADJ/GND pin	7V
Operating Junction Temperature Range	0°C ~ 125°C
Power Dissipation	Internally Limited
Thermal Resistance (Junction to Case)	TO-220 3°C /W
	TO-263 3°C /W
	SOT-223 15°C /W
	TO-252 12.5°C /W
Thermal Resistance (Junction to Ambient) (Assume no ambient airflow, no heatsink)	TO-220 50°C/W
	TO-263 60°C/W
	SOT-223 155°C/W
	TO-252 100°C/W
Storage Temperature Range	- 65°C ~ 150°C
Lead Temperature (Soldering) 10 sec.	260°C

■ ELECTRICAL CHARACTERISTICS ($V_{IN}=5V$, $T_J=25^\circ C$, $I_O=10mA$, Unless otherwise specified)

PARAMETER	TEST CONDITIONS	MIN.	TYP.	MAX.	UNIT
Reference Voltage	$T_J=25^\circ C$ $0^\circ C \leq T_J \leq 125^\circ C$ $2.65V \leq V_{IN} \leq 7V$ $10mA \leq I_O \leq 1A$	1.238 1.225	1.25 1.25	1.262 1.275	V
Output Voltage	AIC1117A-28, $V_{IN}=5V$ AIC1117A-33, $V_{IN}=5V$ AIC1117A-50, $V_{IN}=7V$ AIC1117A $0^\circ C \leq T_J \leq 125^\circ C$ $2.65V \leq V_{IN} \leq 7V$ $10mA \leq I_O \leq 1A$	2.82 3.26 4.95	2.85 3.30 5.00	2.88 3.33 5.05	V
Line Regulation	$2.65 \leq V_{IN} \leq 7V$ $T_J=25^\circ C$ $0^\circ C \leq T_J \leq 125^\circ C$		0.015 0.035	0.2 0.2	% V_{OUT}

ELECTRICAL CHARACTERISTICS (Continued)

PARAMETER	TEST CONDITIONS	MIN.	TYP.	MAX.	UNIT
Load Regulation	$T_J=25^{\circ}\text{C}$, $I_O=10\text{mA} \sim 1\text{A}$ $0^{\circ}\text{C} \leq T_J \leq 125^{\circ}\text{C}$		0.1 0.2	0.3 0.4	$\%V_{OUT}$
Dropout Voltage	$\Delta V_{OUT}, \Delta V_{REF}=1\%$ $I_O=1\text{A}$ $0^{\circ}\text{C} \leq T_J \leq 125^{\circ}\text{C}$		1.3	1.5	V
Current Limit	$0^{\circ}\text{C} \leq T_J \leq 125^{\circ}\text{C}$	1			A
Adjusted Pin Current (I_{ADJ})	$2.65 \leq V_{IN} \leq 7\text{V}$ $10\text{mA} \leq I_O \leq 1\text{A}$ $0^{\circ}\text{C} \leq T_J \leq 125^{\circ}\text{C}$		55	120	μA
Adjusted Pin Current Change (ΔI_{ADJ})	$2.65 \leq V_{IN} \leq 7\text{V}$ $10\text{mA} \leq I_O \leq 1\text{A}$ $0^{\circ}\text{C} \leq T_J \leq 125^{\circ}\text{C}$		0.2	5	μA
Temperature Stability	$I_O=0.5\text{A}$ $0^{\circ}\text{C} \leq T_J \leq 125^{\circ}\text{C}$		0.5		$\% V_{OUT}$
Minimum Load Current (Adj.)	$0^{\circ}\text{C} \leq T_J \leq 125^{\circ}\text{C}$		5	10	mA
Quiescent Current (Fixed Version)	$0^{\circ}\text{C} \leq T_J \leq 125^{\circ}\text{C}$		10	14	mA
RMS Output Noise (% of V_{OUT})	$10\text{Hz} \leq f \leq 10\text{KHz}$		0.003		$\%V_{OUT}$
Ripple Rejection Ratio	120Hz input ripple $C_{OUT}=25\mu\text{F}$	60	72		dB

TYPICAL PERFORMANCE CHARACTERISTICS

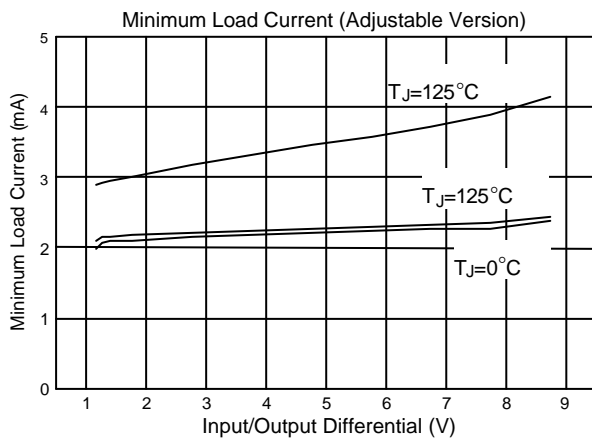
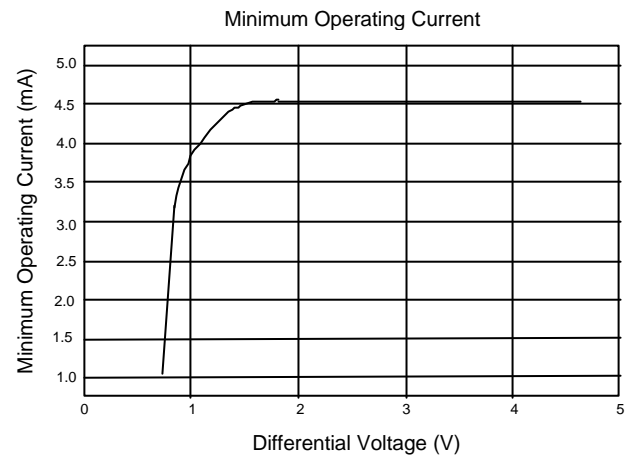
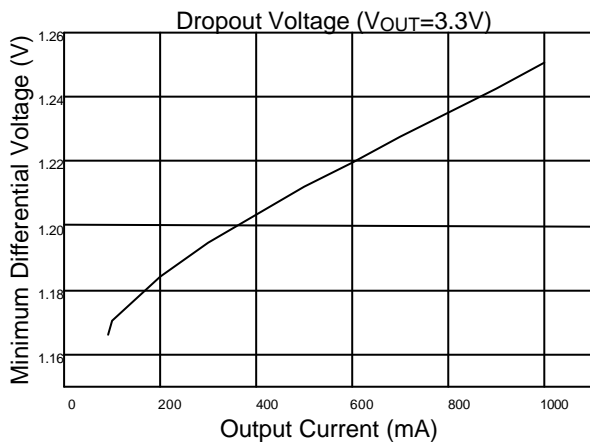
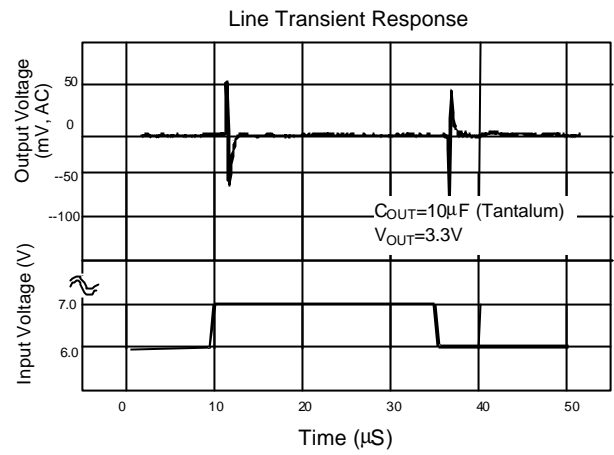
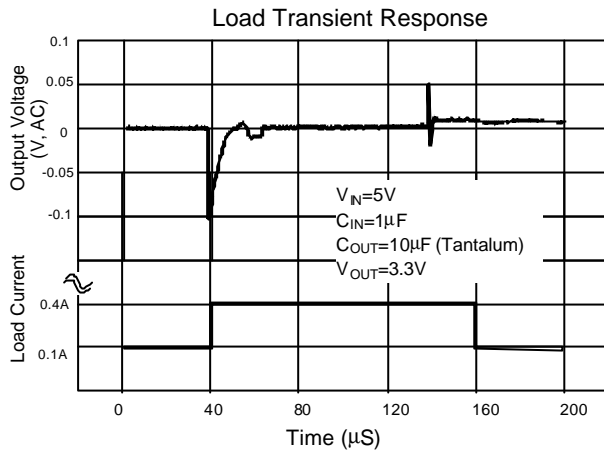

■ BLOCK DIAGRAM

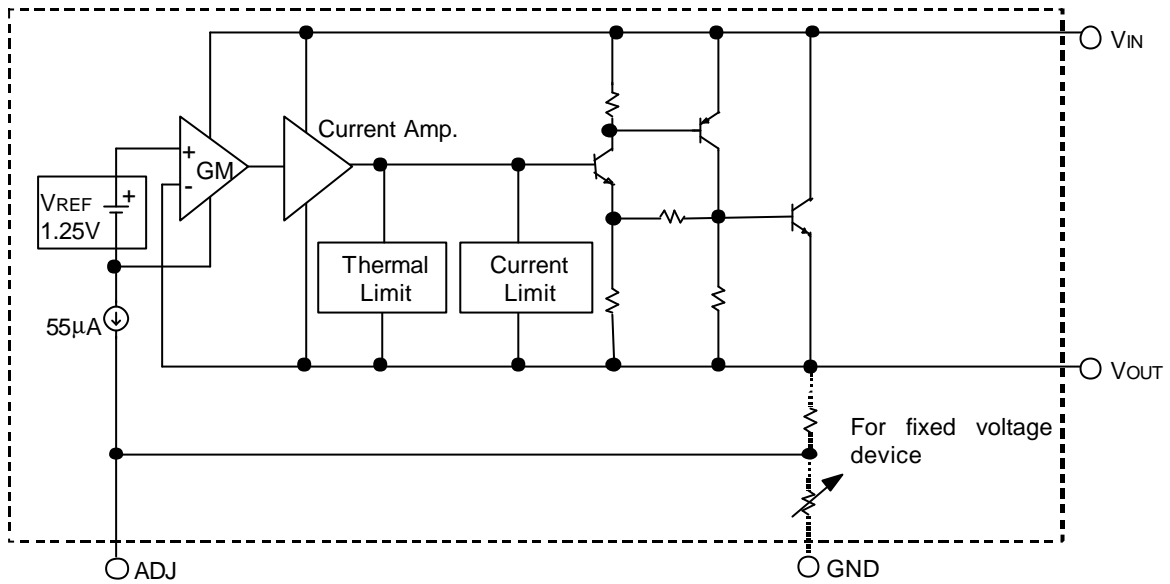

■ PIN DESCRIPTIONS

- ADJ PIN - Providing $V_{REF}=1.25V$ (typ.) for adjustable V_{OUT} . $V_{REF}=V_{OUT}-V_{ADJ}$ and $I_{ADJ}=55\mu A$ (typ.)
- (GND PIN - Power ground.)
- VOUT PIN - Adjustable output voltage.
- VIN PIN - Power Input.

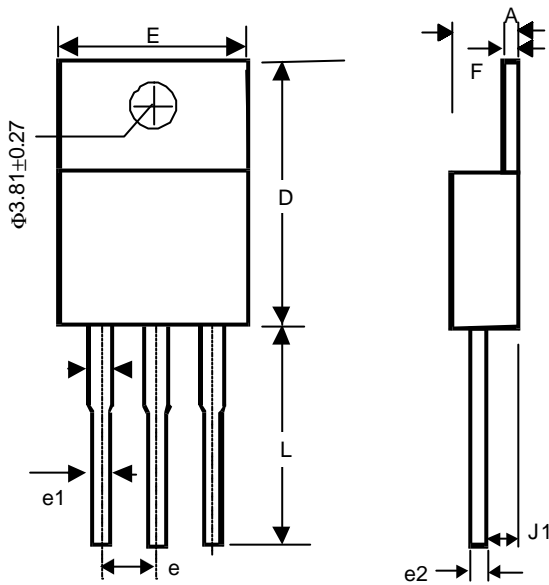
PHYSICAL DIMENSIONS
TO-220 (unit: mm)

SYMBOL	MIN	MAX
A	3.56	4.82
D	14.23	16.51
E	9.66	10.66
e	2.29	2.79
e1	0.50	1.15
e2	-	1.10
F	0.51	1.39
J1	2.04	2.92
L	12.70	14.73

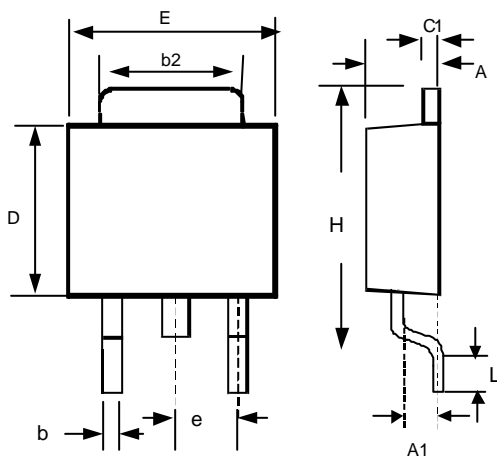
TO-252 (unit: mm)

SYMBOL	MIN	MAX
A	2.19	2.38
A1	1.02	1.27
b	0.64	0.88
b2	5.21	5.46
C1	0.46	0.58
D	5.33	5.59
E	6.35	6.73
e	2.28 (TYP.)	
H	9.40	10.42
L	0.51	-

● SOT-223

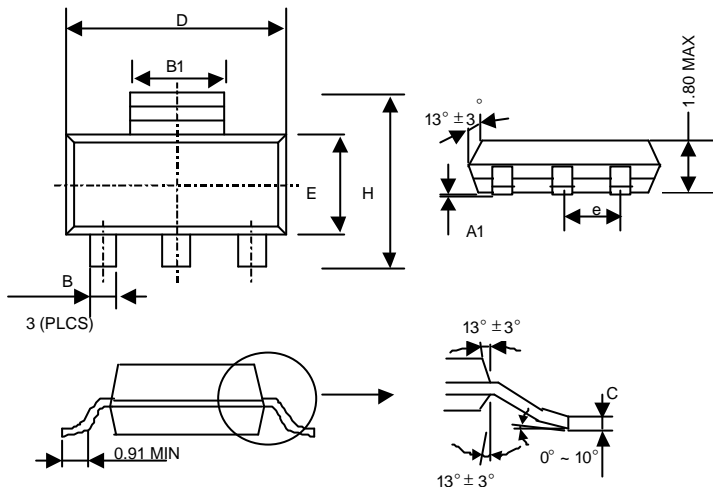

SYMBOL	MIN	MAX
A1	0.02	0.12
B	0.60	0.80
B1	2.90	3.15
C	0.24	0.35
D	6.30	6.80
E	3.30	3.70
e	2.30 (TYP.)	
H	6.70	7.30

● SOT-223 Marking

Part No.	Marking
AIC1117ACY	BS17
AIC1117A-28CY	BS28
AIC1117A-33CY	BS33
AIC1117A-50CY	BS50

● TO-263 (unit: mm)

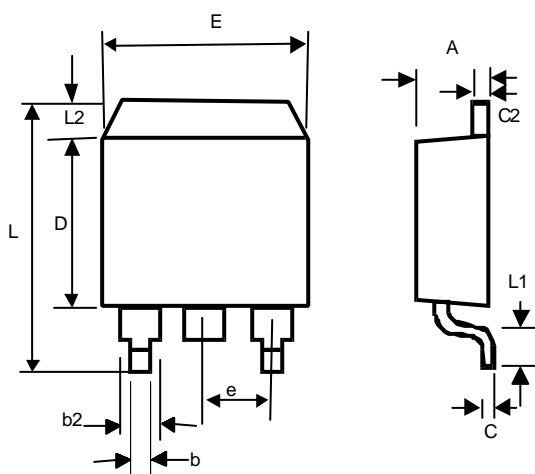

SYMBOL	MIN	MAX
A	4.06	4.83
b	0.50	1.00
b2	1.14	1.40
C	-	0.7
c2	1.14	1.40
D	8.63	9.66
E	9.65	10.29
e	2.54 (TYP.)	
L	14.60	15.88
L1	2.28	2.80
L2	-	1.40