

300mA Low Dropout Linear Regulator

■ FEATURES

- Low Dropout Voltage of 180mV at 100mA Output Current (3.0V Output Version).
- Guaranteed 300mA Output Current.
- Internal 1.3Ω P-MOSFET Draws no Base Current.
- Low Ground Current at 55μA.
- 2% Accuracy Output Voltage of 1.8V/ 2.0V/ 2.5V/ 2.7V/ 3.0V.
- Input Voltage Range up to 12V.
- Needs only 1μF for Stability.
- Current and Thermal Limiting.

■ APPLICATIONS

- Voltage Regulator for CD-ROM Drivers.
- Voltage Regulator for LAN Cards.
- Voltage Regulator for Microprocessor.
- Wireless Communication Systems.
- Battery Powered Systems.

■ DESCRIPTION

The AIC1739 is a 3-pin low dropout linear regulator. The superior characteristics of the AIC1739 include zero base current loss, very low dropout voltage, and 2% accuracy output voltage. Typical ground current remains approximately 55μA, from no load to maximum loading conditions. Dropout voltage is exceptionally low. Output current limiting and thermal limiting are built in to provide maximal protection to the AIC1739 against fault conditions.

The AIC1739 comes in the popular 3-pin SOT-89 and TO-92 packages.

■ TYPICAL APPLICATION CIRCUIT

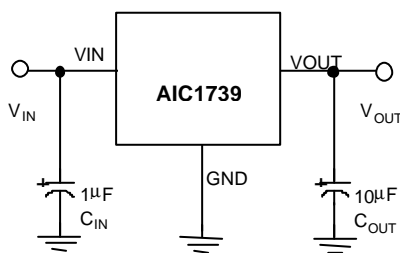

Low Dropout Linear Regulator

ORDERING INFORMATION

AIC1739-XCX

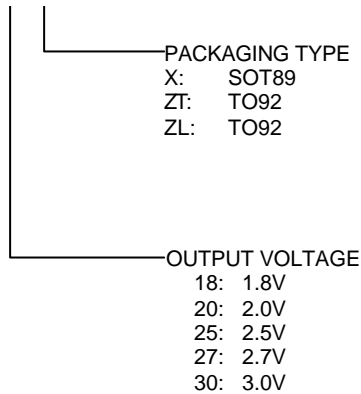

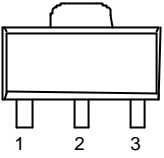
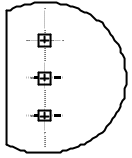
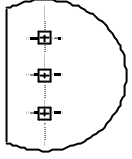
ORDER NUMBER	PIN CONFIGURATION
AIC1739-18CX AIC1739-20CX AIC1739-25CX AIC1739-27CX AIC1739-30CX (SOT-89)	FRONT VIEW 1: VOUT 2: GND 3: VIN 
AIC1739-18CZT AIC1739-20CZT AIC1739-25CZT AIC1739-27CZT AIC1739-30CZT (TO-92)	TOP VIEW 1: GND 2: VIN 3: VOUT 
AIC1739-18CZL AIC1739-20CZL AIC1739-25CZL AIC1739-27CZL AIC1739-30CZL (TO-92 L TYPE)	TOP VIEW 1: VIN 2: GND 3: VOUT 

ABSOLUTE MAXIMUM RATINGS

Input Supply Voltage	-0.3~12V
Operating Junction Temperature Range	-40°C~ 85°C
Storage Temperature Range	-65°C~150°C
Power Dissipation	SOT-89 Package 0.5W TO-92 Package 0.5W

TEST CIRCUIT

Refer to the TYPICAL APPLICATION CIRCUIT

ELECTRICAL CHARACTERISTICS (Ta=25°C, C_{IN}=1mF, C_{OUT}=10mF, unless otherwise specified.)

PARAMETER	TEST CONDITIONS	MIN.	TYP.	MAX.	UNIT	
Output Voltage	No Load				V	
	AIC1739-30	V _{IN} =4.0~12V	2.940	3.000		3.060
	AIC1739-27	V _{IN} =4.0~12V	2.646	2.700		2.754
	AIC1739-25	V _{IN} =4.0~12V	2.550	2.500		2.550
	AIC1739-20	V _{IN} =4.0~12V	1.960	2.000		2.040
AIC1739-18	V _{IN} =4.0~12V	1.764	1.800	1.836		
Output Voltage Temperature Coefficiency	(Note 1)		50	150	PPM/°C	

ELECTRICAL CHARACTERISTICS (Continued)

PARAMETER	TEST CONDITIONS		MIN.	TYP.	MAX.	UNIT
Line Regulation	$I_L=1\text{mA}$	$V_{IN}=4.0\sim 12\text{V}$		3	10	mV
Load Regulation (Note 2)		$V_{IN}=5\text{V}, I_L=0.1\sim 300\text{mA}$		7	25	mV
Current Limit (Note 3)		$V_{IN}=5\text{V}, V_{OUT}=0\text{V}$	320	440		mA
Dropout Voltage (Note 4)	AIC1739s	$I_L=0.1\text{mA}$		0.2	10	mV
	AIC1739-30	$I_L=300\text{mA}$		540	640	
	AIC1739-27	$I_L=300\text{mA}$		570	670	
	AIC1739-25	$I_L=300\text{mA}$		610	710	
	AIC1739-20	$I_L=300\text{mA}$		820	970	
	AIC1739-18	$I_L=300\text{mA}$		920	1070	
Ground Current	$I_O=0.1\text{mA}\sim I_{MAX}$	$V_{IN}=4\sim 12\text{V}$		55	80	μA

Note 1: Guaranteed by design.

Note 2: Regulation is measured at constant junction temperature, using pulse testing with a low ON time.

Note 3: Current limit is measured by pulsing a short time.

Note 4: Dropout voltage is defined as the input to output differential at which the output voltage drops 100mV below the value measured with a 1V differential.

TYPICAL PERFORMANCE CHARACTERISTICS

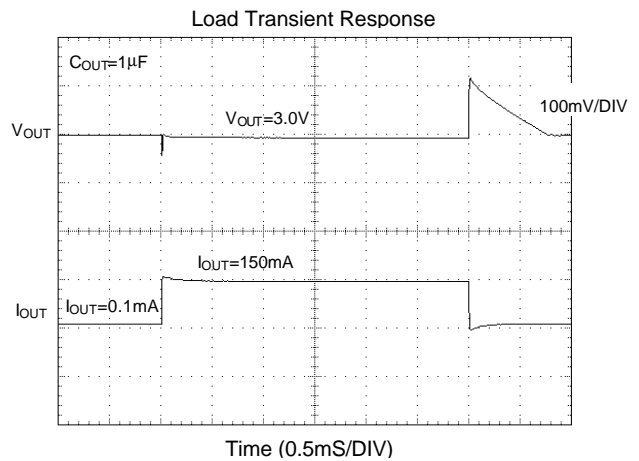
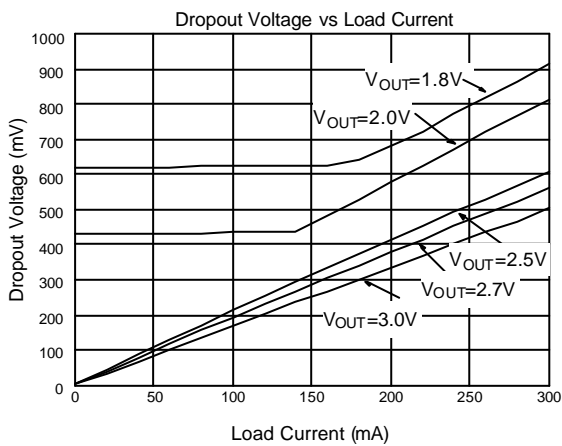

TYPICAL PERFORMANCE CHARACTERISTICS (Continued)

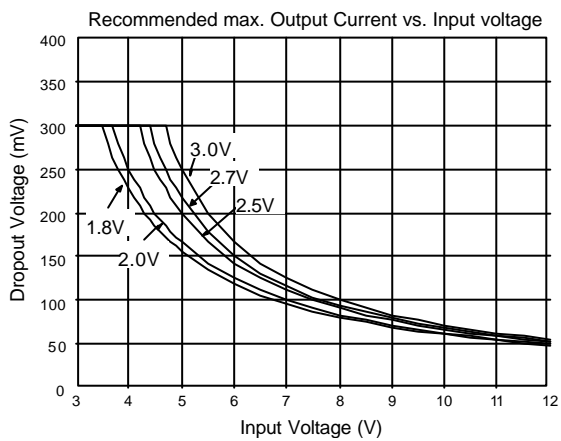
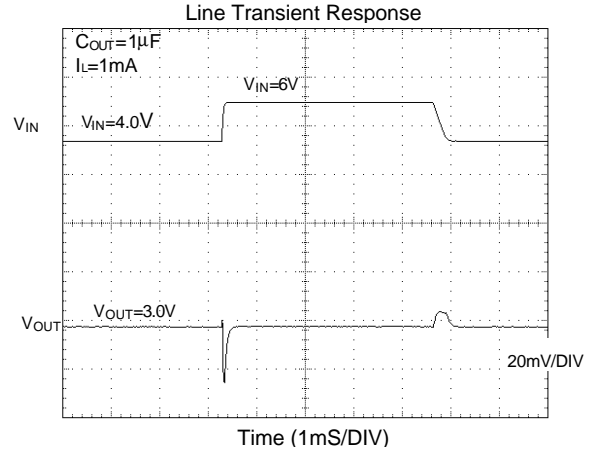
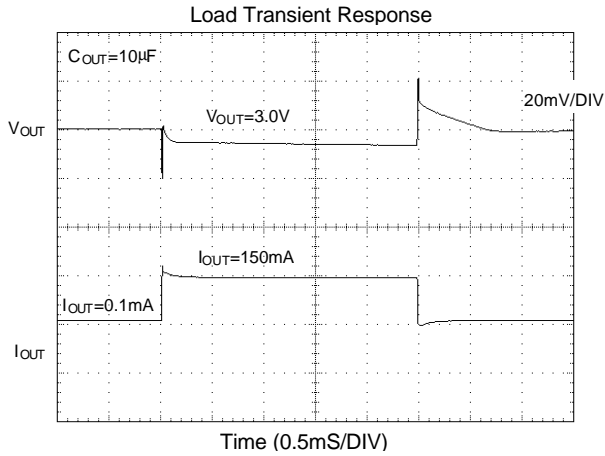

BLOCK DIAGRAM

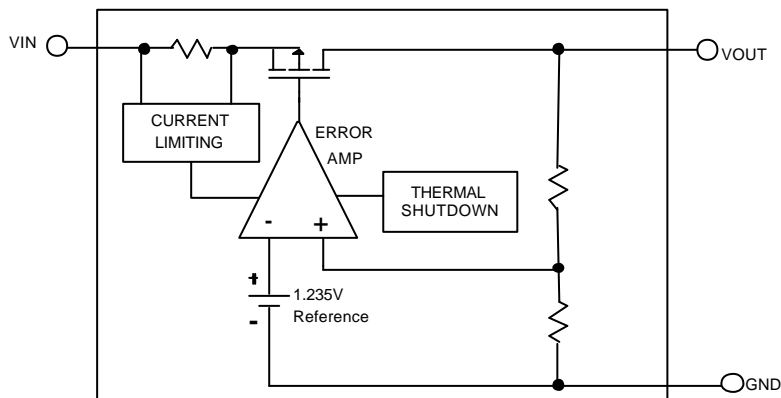

PIN DESCRIPTION

VOUT PIN - Output pin.

GND PIN - Power GND.

VIN PIN - Power Supply Input.

APPLICATION INFORMATIONS

A 1 μ F (or greater) capacitor is required between the AIC1739 output and ground for stability. Without this capacitor the part will oscillate. Even though most types of capacitor may work, the equivalent series resistance (ESR) should be held to 5 Ω or less if Aluminum electrolytic type is used. Many Aluminum electrolytics have electrolytes that freeze at about -30°C, so solid tantalums are recommended for operation below -25°C. The

value of this capacitor may be increased without limit.

A 0.1 μ F capacitor (or greater) should be placed from the AIC1739 input to ground if the lead inductance between the input and power source exceeds 500nH (approximately 10 inches of trace).

PHYSICAL DIMENSIONS

● SOT-89 (unit: mm)

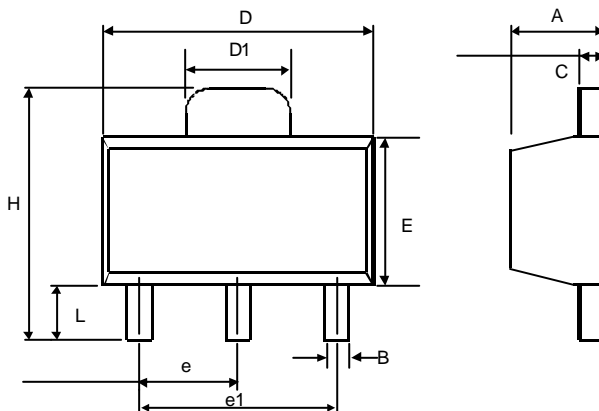

SYMBOL	MIN	MAX
A	1.40	1.60
B	0.36	0.48
C	0.35	0.44
D	4.40	4.60
D1	1.62	1.83
E	2.29	2.60
e	1.50 (TYP.)	
e1	3.00 (TYP.)	
H	3.94	4.25
L	0.89	1.20

SOT-89 MARKING

Part No.	Marking
AIC1739-18	AY18
AIC1739-20	AY20
AIC1739-25	AY25
AIC1739-27	AY27
AIC1739-30	AY30

● TO-92 (unit: mm)

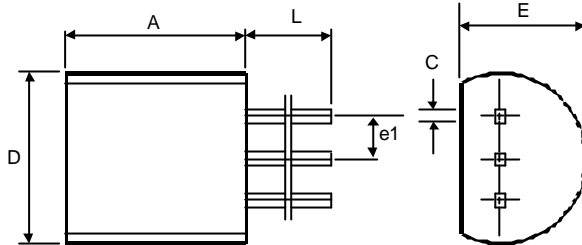

SYMBOL	MIN	MAX
A	4.32	5.33
C	0.38 (TYP.)	
D	4.40	5.20
E	3.17	4.20
e1	1.27 (TYP.)	
L	12.7	-