

# GaAs IC High Isolation SPDT Non-Reflective Switch with Driver DC–6.0 GHz

**AS196-307**

## Features

- Positive Voltage Control (0/+3 to 0/+5 V)
- High Isolation (55 dB @ 0.9 GHz and 1.9 GHz)
- LPCC 4 x 4 mm Package
- Integrated Silicon CMOS Driver
- Non-Reflective

## Description

The AS196-307 is a GaAs FET IC SPDT non-reflective switch packaged in a 16 lead leadless exposed pad plastic package for low cost, high isolation commercial applications. Ideal building block for base station applications where synthesizer isolation is critical. Typical applications include GSM, PCS, WCDMA, 2.4 and 5.8 GHz ISM and wireless local loop.

## LPCC 4 x 4 (-307)

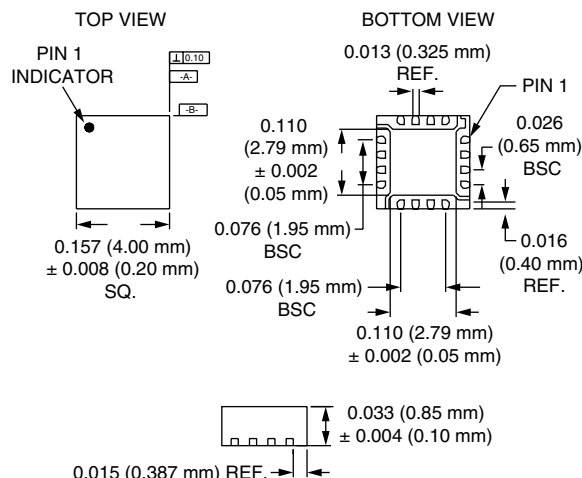

## Electrical Specifications (0, +5 V) 25°C

Parameter <sup>1</sup>	Frequency	Min.	Typ.	Max.	Unit
Insertion Loss	DC–2.0 GHz		0.9	1.15	dB
	DC–3.0 GHz		1.0	1.25	dB
	DC–4.0 GHz		1.2	1.4	dB
	DC–6.0 GHz		2.0	2.5	dB
Isolation <sup>2</sup>	DC–2.0 GHz	50	55		dB
	DC–3.0 GHz	43	50		dB
	DC–4.0 GHz	35	40		dB
	DC–6.0 GHz	25	30		dB
VSWR (On State)	DC–2.0 GHz		1.3:1	1.5:1	
	DC–6.0 GHz		1.3:1	1.6:1	
VSWR (Off State)	0.5–6.0 GHz		1.35:1	1.7:1	

## Operating Characteristics at 25°C (0, +5 V)

Parameter	Condition	Frequency	Min.	Typ.	Max.	Unit
Switching Characteristics <sup>3</sup>	Rise, Fall (10/90% or 90/10% RF)			30		ns
	On, Off (50% CTL to 90/10% RF)			50		ns
	Video Feedthru			25		mV
Input Power for 1 dB Compression	0/+3 V	0.9–6.0 GHz		21		dBm
	0/+5 V	0.9–6.0 GHz		27		dBm
Intermodulation Intercept Point (IP3)	For Two-tone Input Power +8 dBm	0/+3 V	0.9–6.0 GHz		38	dBm
		0/+5 V	0.9–6.0 GHz		46	dBm
Control Voltages	$V_{CTL} = "0"$		0.0		0.5	V
	$V_{CTL} = "1"$ for $V_{CC} = 5 V @ 200 \mu A$ Max.		3.5		5.0	V

1. All measurements made in a 50  $\Omega$  system, unless otherwise specified.

2. Backside of exposed pad must be connected to RF ground to obtain specified isolation.

3. Video feedthru measured for 3 ns risetime pulse.

### Typical Performance Data (0, +5 V)

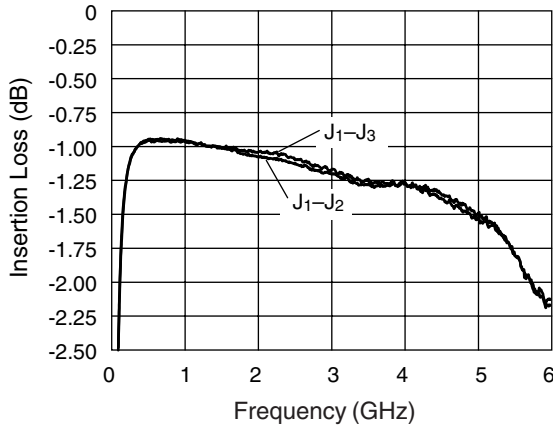

Insertion Loss vs. Frequency

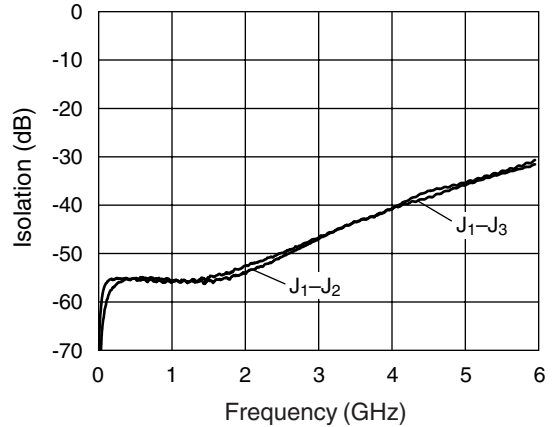

Isolation vs. Frequency

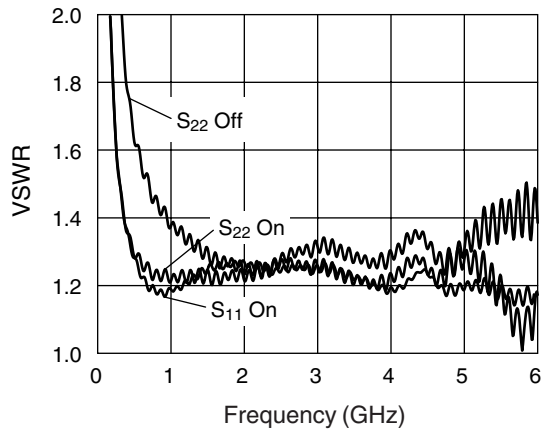

VSWR vs. Frequency

### Absolute Maximum Ratings

Characteristic	Value
RF Input Power	1 W Max. > 500 MHz, 0/+8 V Control
Control Voltage	-0.2 V, +8 V
Operating Temperature	-40°C to +85°C
Storage Temperature	-65°C to +150°C
$\theta_{JC}$	25°C/W

### Truth Table

$V_{CTL}$	J <sub>1</sub> -J <sub>2</sub>	J <sub>1</sub> -J <sub>3</sub>
0	Insertion Loss	Isolation
1	Isolation	Insertion Loss

"0" = 0–0.5 V.  
"1" = 3.5–5 V.  
 $V_{CC}$  = 5 V.

### Surface Mount Land Pattern

4 x 4 mm LPGA-16 Lead

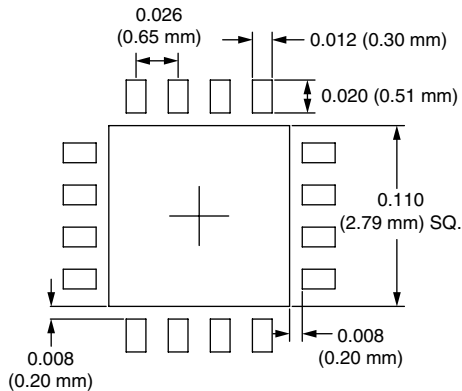

### Pin Out (Bottom View)

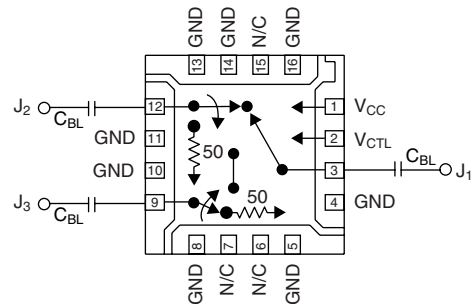

$C_{BL}$  = 47 pF for operation > 500 MHz.