



3V 1M × 8/512K × 16 CMOS Flash EEPROM

Features

- Organization: 1M×8/512K×16
- Sector architecture
 - One 16K; two 8K; one 32K; and fifteen 64K byte sectors
 - One 8K; two 4K; one 16K; and fifteen 32K word sectors
 - Boot code sector architecture—T (top) or B (bottom)
 - Erase any combination of sectors or full chip
- Single 2.7-3.6V power supply for read/write operations
- Sector protection
- High speed 70/80/90/120 ns address access time
- Automated on-chip programming algorithm
 - Automatically programs/verifies data at specified address
- Automated on-chip erase algorithm
 - Automatically preprograms/erases chip or specified sectors
- Hardware $\overline{\text{RESET}}$ pin
 - Resets internal state machine to read mode

- Low power consumption
 - 200 nA typical automatic sleep mode current
 - 200 nA typical standby current
 - 10 mA typical read current
- JEDEC standard software, packages and pinouts
 - 48-pin TSOP
 - 44-pin SO; availability TBD
- Detection of program/erase cycle completion
 - DQ7 $\overline{\text{DATA}}$ polling
 - DQ6 toggle bit
 - DQ2 toggle bit
 - RY/ $\overline{\text{BY}}$ output
- Erase suspend/resume
 - Supports reading data from or programming data to a sector not being erased
- Low V_{CC} write lock-out below 1.5V
- 10 year data retention at 150C
- 100,000 write/erase cycle endurance

Logic block diagram

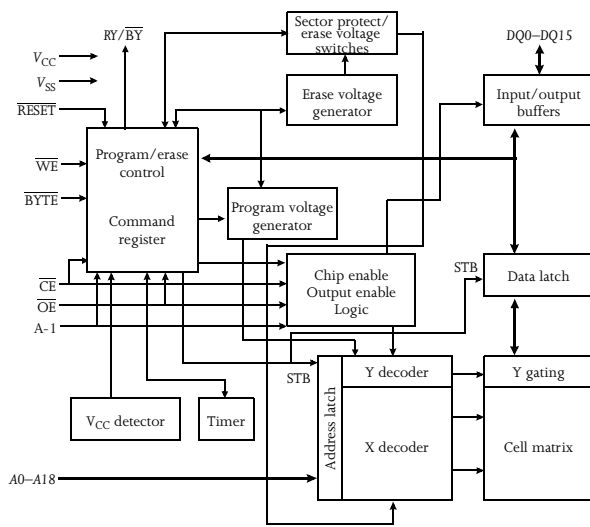

Pin arrangement

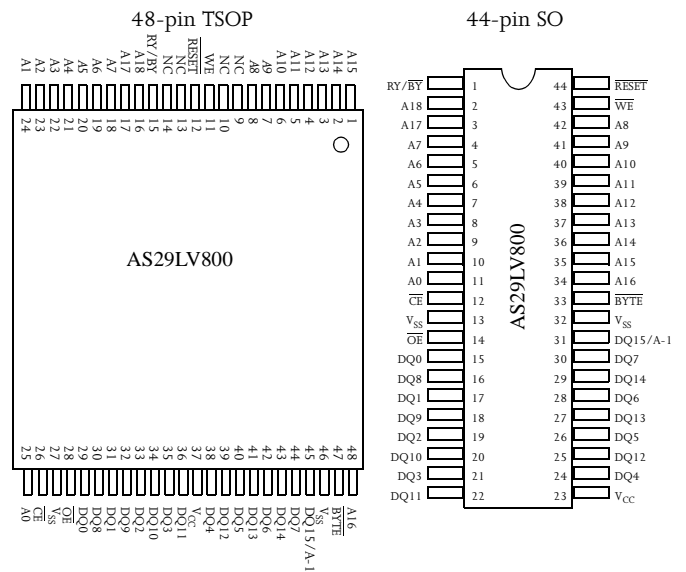

Selection guide

		29LV800-70R*	29LV800-80	29LV800-90	29LV800-120	Unit
Maximum access time	t_{AA}	70	80	90	120	ns
Maximum chip enable access time	t_{CE}	70	80	90	120	ns
Maximum output enable access time	t_{OE}	30	30	35	50	ns

* Regulated voltage range of 3.0 to 3.6V



Functional description

The AS29LV800 is an 8 megabit, 3.0 volt Flash memory organized as 1 Megabyte of 8 bits/512Kbytes of 16 bits each. For flexible erase and program capability, the 8 megabits of data is divided into nineteen sectors: one 16K, two 8K, one 32K, and fifteen 64k byte sectors; or one 8K, two 4K, one 16K, and fifteen 32K word sectors. The $\times 8$ data appears on DQ0–DQ7; the $\times 16$ data appears on DQ0–DQ15. The AS29LV800 is offered in JEDEC standard 48-pin TSOP and 44-pin SOP packages. This device is designed to be programmed and erased in-system with a single 3.0V V_{CC} supply. The device can also be reprogrammed in standard EPROM programmers.

The AS29LV800 offers access times of 70/80/90/120 ns, allowing 0-wait state operation of high speed microprocessors. To eliminate bus contention the device has separate chip enable (\overline{CE}), write enable (\overline{WE}), and output enable (\overline{OE}) controls. Word mode ($\times 16$ output) is selected by $\overline{BYTE} = \text{high}$. Byte mode ($\times 8$ output) is selected by $\overline{BYTE} = \text{low}$.

The AS29LV800 is fully compatible with the JEDEC single power supply Flash standard. Write commands are sent to the command register using standard microprocessor write timings. An internal state-machine uses register contents to control the erase and programming circuitry. Write cycles also internally latch addresses and data needed for the programming and erase operations. Read data from the device occurs in the same manner as other Flash or EPROM devices. Use the program command sequence to invoke the automated on-chip programming algorithm that automatically times the program pulse widths and verifies proper cell margin. Use the erase command sequence to invoke the automated on-chip erase algorithm that preprograms the sector (if it is not already programmed before executing the erase operation), times the erase pulse widths, and verifies proper cell margin.

Boot sector architecture enables the system to boot from either the top (AS29LV800T) or the bottom (AS29LV800B) sector. Sector erase architecture allows specified sectors of memory to be erased and reprogrammed without altering data in other sectors. A sector typically erases and verifies within 1.0 seconds. Hardware sector protection disables both program and erase operations in all, or any combination of, the nineteen sectors. The device provides true background erase with Erase Suspend, which puts erase operations on hold to either read data from, or program data to, a sector that is not being erased. The chip erase command will automatically erase all unprotected sectors.

A factory shipped AS29LV800 is fully erased (all bits = 1). The programming operation sets bits to 0. Data is programmed into the array one byte at a time in any sequence and across sector boundaries. A sector must be erased to change bits from 0 to 1. Erase returns all bytes in a sector to the erased state (all bits = 1). Each sector is erased individually with no effect on other sectors.

The device features single 3.0V power supply operation for Read, Write, and Erase functions. Internally generated and regulated voltages are provided for the Program and Erase operations. A low V_{CC} detector automatically inhibits write operations during power transitions. The $\overline{RY}/\overline{BY}$ pin, \overline{DATA} polling of DQ7, or toggle bit (DQ6) may be used to detect end of program or erase operations. The device automatically resets to the read mode after program/erase operations are completed. DQ2 indicates which sectors are being erased.

The AS29LV800 resists accidental erasure or spurious programming signals resulting from power transitions. Control register architecture permits alteration of memory contents only after successful completion of specific command sequences. During power up, the device is set to read mode with all program/erase commands disabled when V_{CC} is less than V_{LKO} (lockout voltage). The command registers are not affected by noise pulses of less than 5 ns on \overline{OE} , \overline{CE} , or \overline{WE} . To initiate write commands, \overline{CE} and \overline{WE} must be logical zero and \overline{OE} a logical 1.

When the device's hardware \overline{RESET} pin is driven low, any program/erase operation in progress is terminated and the internal state machine is reset to read mode. If the \overline{RESET} pin is tied to the system reset circuitry and a system reset occurs during an automated on-chip program/erase algorithm, data in address locations being operated on may become corrupted and requires rewriting. Resetting the device enables the system's microprocessor to read boot-up firmware from the Flash memory.

The AS29LV800 uses Fowler-Nordheim tunnelling to electrically erase all bits within a sector simultaneously. Bytes are programmed one at a time using EPROM programming mechanism of hot electron injection.



Operating modes

Mode	\overline{CE}	\overline{OE}	\overline{WE}	A0	A1	A6	A9	\overline{RESET}	DQ
ID read MFR code	L	L	H	L	L	L	V _{ID}	H	Code
ID read device code	L	L	H	H	L	L	V _{ID}	H	Code
Read	L	L	H	A0	A1	A6	A9	H	D _{OUT}
Standby	H	X	X	X	X	X	X	H	High Z
Output disable	L	H	H	X	X	X	X	H	High Z
Write	L	H	L	A0	A1	A6	A9	H	D _{IN}
Enable sector protect	L	V _{ID}	Pulse/L	L	H	L	V _{ID}	H	X
Sector unprotect	L	V _{ID}	Pulse/L	L	H	H	V _{ID}	H	X
Temporary sector unprotect	X	X	X	X	X	X	X	V _{ID}	X
Verify sector protect [†]	L	L	H	L	H	L	V _{ID}	H	Code
Verify sector unprotect [†]	L	L	H	L	H	H	V _{ID}	H	Code
Hardware Reset	X	X	X	X	X	X	X	L	High Z

L = Low (<V_{IL}) = logic 0; H = High (>V_{IH}) = logic 1; V_{ID} = 10.0 ± 1.0V; X = don't care.

In ×16 mode, BYTE = V_{IH}. In ×8 mode, BYTE = V_{IL} with DQ8-DQ14 in high Z and DQ15 = A-1.

[†]Verification of sector protect/unprotect during A9 = V_{ID}.

Mode definitions

Item	Description
ID MFR code, device code	Selected by A9 = V _{ID} (9.5V–10.5V), $\overline{CE} = \overline{OE} = A1 = A6 = L$, enabling outputs. When A0 is low (V _{IL}) the output data = 52h, a unique Mfr. code for Alliance Semiconductor Flash products. When A0 is high (V _{IH}), D _{OUT} represents the device code for the AS29LV800.
Read mode	Selected with $\overline{CE} = \overline{OE} = L$, $\overline{WE} = H$. Data is valid in t _{ACC} time after addresses are stable, t _{CE} after \overline{CE} is low and t _{OE} after \overline{OE} is low.
Standby	Selected with $\overline{CE} = H$. Part is powered down, and I _{CC} reduced to <1.0 μA when $\overline{CE} = V_{CC} \pm 0.3V = \overline{RESET}$. If activated during an automated on-chip algorithm, the device completes the operation before entering standby.
Output disable	Part remains powered up; but outputs disabled with \overline{OE} pulled high.
Write	Selected with $\overline{CE} = \overline{WE} = L$, $\overline{OE} = H$. Accomplish all Flash erasure and programming through the command register. Contents of command register serve as inputs to the internal state machine. Address latching occurs on the falling edge of \overline{WE} or \overline{CE} , whichever occurs later. Data latching occurs on the rising edge \overline{WE} or \overline{CE} , whichever occurs first. Filters on \overline{WE} prevent spurious noise events from appearing as write commands.
Enable sector protect	Hardware protection circuitry implemented with external programming equipment causes the device to disable program and erase operations for specified sectors. For in-system sector protection, refer to Sector protect algorithm on page 14.
Sector unprotect	Disables sector protection for all sectors using external programming equipment. All sectors must be protected prior to sector unprotection. For in-system sector unprotection, refer to Sector unprotect algorithm on page 14.
Verify sector protect/unprotect	Verifies write protection for sector. Sectors are protected from program/erase operations on commercial programming equipment. Determine if sector protection exists in a system by writing the ID read command sequence and reading location XXX02h, where address bits A12–18 select the defined sector addresses. A logical 1 on DQ0 indicates a protected sector; a logical 0 indicates an unprotected sector.



Item	Description
Temporary sector unprotect	Temporarily disables sector protection for in-system data changes to protected sectors. Apply +10V to $\overline{\text{RESET}}$ to activate temporary sector unprotect mode. During temporary sector unprotect mode, program protected sectors by selecting the appropriate sector address. All protected sectors revert to protected state on removal of +10V from $\overline{\text{RESET}}$.
$\overline{\text{RESET}}$	Resets the internal state machine to read mode. If device is programming or erasing when $\overline{\text{RESET}} = \text{L}$, data may be corrupted.
Deep power down	Hold $\overline{\text{RESET}}$ low to enter deep power down mode (<1 μA). Recovery time to start of first read cycle is 50ns.
Automatic sleep mode	Enabled automatically when addresses remain stable for 300ns. Typical current draw is 1 μA . Existing data is available to the system during this mode. If an address is changed, automatic sleep mode is disabled and new data is returned within standard access times.

Flexible sector architecture

Bottom boot sector architecture (AS29LV800B)

Sector	Bottom boot sector architecture (AS29LV800B)		Size (Kbytes)
	$\times 8$	$\times 16$	
0	0000h–03FFFh	0000h–01FFFh	16
1	0400h–05FFFh	0200h–02FFFh	8
2	0600h–07FFFh	0300h–03FFFh	8
3	0800h–0FFFFh	0400h–07FFFh	32
4	1000h–1FFFFh	0800h–0FFFFh	64
5	2000h–2FFFFh	1000h–17FFFh	64
6	3000h–3FFFFh	1800h–1FFFFh	64
7	4000h–4FFFFh	2000h–27FFFh	64
8	5000h–5FFFFh	2800h–2FFFFh	64
9	6000h–6FFFFh	3000h–37FFFh	64
10	7000h–7FFFFh	3800h–3FFFFh	64
11	8000h–8FFFFh	4000h–47FFFh	64
12	9000h–9FFFFh	4800h–4FFFFh	64
13	A000h–AFFFFh	5000h–57FFFh	64
14	B000h–BFFFFh	5800h–5FFFFh	64
15	C000h–CFFFFh	6000h–67FFFh	64
16	D000h–DFFFFh	6800h–6FFFFh	64
17	E000h–EFFFFh	7000h–77FFFh	64
18	F000h–FFFFh	7800h–7FFFFh	64

Top boot sector architecture (AS29LV800T)

Sector	Top boot sector architecture (AS29LV800T)		Size (Kbytes)
	$\times 8$	$\times 16$	
0	0000h–0FFFFh	0000h–07FFFh	64
1	1000h–1FFFFh	0800h–0FFFFh	64
2	2000h–2FFFFh	1000h–17FFFh	64
3	3000h–3FFFFh	1800h–1FFFFh	64
4	4000h–4FFFFh	2000h–27FFFh	64
5	5000h–5FFFFh	2800h–2FFFFh	64
6	6000h–6FFFFh	3000h–37FFFh	64
7	7000h–7FFFFh	3800h–3FFFFh	64
8	8000h–8FFFFh	4000h–47FFFh	64
9	9000h–9FFFFh	4800h–4FFFFh	64
10	A000h–AFFFFh	5000h–57FFFh	64
11	B000h–BFFFFh	5800h–5FFFFh	64
12	C000h–CFFFFh	6000h–67FFFh	64
13	D000h–DFFFFh	6800h–6FFFFh	64
14	E000h–EFFFFh	7000h–77FFFh	64
15	F000h–F7FFFh	7800h–7BFFFh	32
16	F800h–F9FFFh	7C00h–7CFFFh	8
17	FA00h–FBFFFh	7D00h–7DFFFh	8
18	FC00h–FFFFh	7E00h–7FFFFh	16

In word mode, there are one 8K word, two 4K word, one 16K word, and fifteen 32K word sectors. Address range is A18–A-1 if $\overline{\text{BYTE}} = \text{V}_{\text{IL}}$; address range is A18–A0 if $\overline{\text{BYTE}} = \text{V}_{\text{IH}}$.



ID Sector address table

Sector	Bottom boot sector address (AS29LV800B)							Top boot sector address (AS29LV800T)						
	A18	A17	A16	A15	A14	A13	A12	A18	A17	A16	A15	A14	A13	A12
0	0	0	0	0	0	0	X	0	0	0	0	X	X	X
1	0	0	0	0	0	1	0	0	0	0	1	X	X	X
2	0	0	0	0	0	1	1	0	0	1	0	X	X	X
3	0	0	0	0	1	X	X	0	0	1	1	X	X	X
4	0	0	0	1	X	X	X	0	1	0	0	X	X	X
5	0	0	1	0	X	X	X	0	1	0	1	X	X	X
6	0	0	1	1	X	X	X	0	1	1	0	X	X	X
7	0	1	0	0	X	X	X	0	1	1	1	X	X	X
8	0	1	0	1	X	X	X	1	0	0	0	X	X	X
9	0	1	1	0	X	X	X	1	0	0	1	X	X	X
10	0	1	1	1	X	X	X	1	0	1	0	X	X	X
11	1	0	0	0	X	X	X	1	0	1	1	X	X	X
12	1	0	0	1	X	X	X	1	1	0	0	X	X	X
13	1	0	1	0	X	X	X	1	1	0	1	X	X	X
14	1	0	1	1	X	X	X	1	1	1	0	X	X	X
15	1	1	0	0	X	X	X	1	1	1	1	0	X	X
16	1	1	0	1	X	X	X	1	1	1	1	1	0	0
17	1	1	1	0	X	X	X	1	1	1	1	1	0	1
18	1	1	1	1	X	X	X	1	1	1	1	1	1	X

READ codes

Mode	A18–A12	A6	A1	A0	Code
MFR code (Alliance Semiconductor)	X	L	L	L	52h
Device code	×8 T boot	X	L	L	DAh
	×8 B boot	X	L	L	5Bh
	×16 T boot	X	L	L	22DAh
	×16 B boot	X	L	L	225Bh
Sector protection	Sector address	L	H	L	01h protected 00h unprotected

Key: L =Low (<V_{IL}); H = High (>V_{IH}); X =Don't care



Command format

Command sequence	Required bus write cycles	1st bus cycle		2nd bus cycle		3rd bus cycle		4th bus cycle		5th bus cycle		6th bus cycle	
		Address	Data	Address	Data	Address	Data	Address	Data	Address	Data	Address	Data
Reset/Read	1	XXXh	F0h	Read Address	Read Data								
Reset/Read	×16	555h	AAh	2AAh	55h	555h	F0h	Read Address	Read Data				
	×8	AAAh		555h		AAAh							
Autoselect ID Read	×16	555h	AAh	2AAh	55h	555h	90h	01h Device code	22DAh (T) 225Bh (B)				
	×8	AAAh		555h		AAAh		02h Device code	DAh (T) 5Bh (B)				
	×16	555h	AAh	2AAh	55h	555h	90h	00h MFR code	0052h				
	×8	AAAh		555h		AAAh		52h					
	×16	555h	AAh	2AAh	55h	555h	90h	XXX02h Sector protection	0001h = protected 0000h = unprotected				
	×8	AAAh		555h		AAAh		XXX04h Sector protection	0001h=protected 0000h=unprotected				
Program	×16	555h	AAh	2AAh	55h	555h	A0h	Program Address	Program Data				
	×8	AAAh		555h		AAAh							
Unlock bypass	×16	555	AAh	2AA	55h	555	20h						
	×8	AAA		555		AAA							
Unlock bypass program	2	XXX	A0h	Program address	Program data								
Unlock bypass reset	2	XXX	90h	XXX	00h								
Chip Erase	×16	555h	AAh	2AAh	55h	555h	80h	555h	AAh	2AAh	55h	555h	10h
	×8	AAAh		555h		AAAh		555h		AAAh			
Sector Erase	×16	555h	AAh	2AAh	55h	555h	80h	555h	AAh	2AAh	55h	Sector Address	30h
	×8	AAAh		555h		AAAh		555h		AAAh			
Sector Erase Suspend	1	XXXh	B0h										
Sector Erase Resume	1	XXXh	30h										

- 1 Bus operations defined in "Mode definitions," on page 3.
- 2 Reading from and programming to non-erasing sectors allowed in Erase Suspend mode.
- 3 Address bits A11-A18 = X = Don't Care for all address commands except where Program Address and Sector Address are required.
- 4 Data bits DQ15-DQ8 = don't care for unlock and command cycles.
- 5 The Unlock Bypass command must be initiated before the Unlock Bypass Program command.
- 6 The Unlock Bypass Reset command returns the device to reading array data when it is in the unlock bypass mode.



Command definitions

Item	Description
Reset/Read	<p>Initiate read or reset operations by writing the Read/Reset command sequence into the command register. This allows the microprocessor to retrieve data from the memory. Device remains in read mode until command register contents are altered.</p> <p>Device automatically powers up in read/reset state. This feature allows only reads, therefore ensuring no spurious memory content alterations during power up.</p>
ID Read	<p>AS29LV800 provides manufacturer and device codes in two ways. External PROM programmers typically access the device codes by driving +10V on A9. AS29LV800 also contains an ID Read command to read the device code with only +3V, since multiplexing +10V on address lines is generally undesirable.</p> <p>Initiate device ID read by writing the ID Read command sequence into the command register. Follow with a read sequence from address XXX00h to return MFR code. Follow ID Read command sequence with a read sequence from address XXX01h to return device code.</p> <p>To verify write protect status on sectors, read address XXX02h. Sector addresses A18–A12 produce a 1 on DQ0 for protected sector and a 0 for unprotected sector.</p> <p>Exit from ID read mode with Read/Reset command sequence.</p>
Hardware Reset	<p>Holding $\overline{\text{RESET}}$ low for 500 ns resets the device, terminating any operation in progress; data handled in the operation is corrupted. The internal state machine resets 20 μs after $\overline{\text{RESET}}$ is driven low. $\text{RY}/\overline{\text{BY}}$ remains low until internal state machine resets. After $\overline{\text{RESET}}$ is set high, there is a delay of 50 ns for the device to permit read operations.</p>
Byte/word Programming	<p>Programming the AS29LV800 is a four bus cycle operation performed on a byte-by-byte or word-by-word basis. Two unlock write cycles precede the Program Setup command and program data write cycle. Upon execution of the program command, no additional CPU controls or timings are necessary. Addresses are latched on the falling edge of $\overline{\text{CE}}$ or $\overline{\text{WE}}$, whichever is last; data is latched on the rising edge of $\overline{\text{CE}}$ or $\overline{\text{WE}}$, whichever is first. The AS29LV800's automated on-chip program algorithm provides adequate internally-generated programming pulses and verifies the programmed cell margin.</p> <p>Check programming status by sampling data on the $\text{RY}/\overline{\text{BY}}$ pin, or either the $\overline{\text{DATA}}$ polling (DQ7) or toggle bit (DQ6) at the program address location. The programming operation is complete if DQ7 returns equivalent data, if DQ6 = no toggle, or if $\text{RY}/\overline{\text{BY}}$ pin = high.</p> <p>The AS29LV800 ignores commands written during programming. A hardware reset occurring during programming may corrupt the data at the programmed location.</p> <p>AS29LV800 allows programming in any sequence, across any sector boundary. Changing data from 0 to 1 requires an erase operation. Attempting to program data 0 to 1 results in either DQ5 = 1 (exceeded programming time limits); reading this data after a read/reset operation returns a 0. When programming time limit is exceeded, DQ5 reads high, and DQ6 continues to toggle. In this state, a Reset command returns the device to read mode.</p>



Item	Description
Unlock Bypass Command Sequence	<p>The unlock bypass feature increases the speed at which the system programs bytes or words to the device because it bypasses the first two unlock cycles of the standard program command sequence.</p> <p>To initiate the unlock bypass command sequence, two unlock cycles must be written, then followed by a third cycle which has the unlock bypass command, 20h.</p> <p>The device then begins the unlock bypass mode. In order to program in this mode, a two cycle unlock bypass program sequence is required. The first cycle has the unlock bypass program command, A0h. It is followed by a second cycle which has the program address and data. To program additional data, the same sequence must be followed.</p> <p>The unlock bypass mode has two valid commands, the Unlock Bypass Program command and the Unlock Bypass Reset command. The only way the system can exit the unlock bypass mode is by issuing the unlock bypass reset command sequence. This sequence involves two cycles. The first cycle contains the data, 90h. The second cycle contains the data 00h. Addresses are don't care for both cycles. The device then returns to reading array data.</p>
Chip Erase	<p>Chip erase requires six bus cycles: two unlock write cycles; a setup command, two additional unlock write cycles; and finally the Chip Erase command.</p> <p>Chip erase does not require logical 0s to be written prior to erasure. When the automated on-chip erase algorithm is invoked with the Chip Erase command sequence, AS29LV800 automatically programs and verifies the entire memory array for an all-zero pattern prior to erase. The 29LV800 returns to read mode upon completion of chip erase unless DQ5 is set high as a result of exceeding time limit.</p>
Sector Erase	<p>Sector erase requires six bus cycles: two unlock write cycles, a setup command, two additional unlock write cycles, and finally the Sector Erase command. Identify the sector to be erased by addressing any location in the sector. The address is latched on the falling edge of \overline{WE}; the command, 30h is latched on the rising edge of \overline{WE}. The sector erase operation begins after a sector erase time-out.</p> <p>To erase multiple sectors, write the Sector Erase command to each of the addresses of sectors to erase after following the six bus cycle operation above. Timing between writes of additional sectors must be less than the erase time-out period, or the AS29LV800 ignores the command and erasure begins. During the time-out period any falling edge of \overline{WE} resets the time-out. Any command (other than Sector Erase or Erase Suspend) during time-out period resets the AS29LV800 to read mode, and the device ignores the sector erase command string. Erase such ignored sectors by restarting the Sector Erase command on the ignored sectors.</p> <p>The entire array need not be written with 0s prior to erasure. AS29LV800 writes 0s to the entire sector prior to electrical erase; writing of 0s affects only selected sectors, leaving non-selected sectors unaffected. AS29LV800 requires no CPU control or timing signals during sector erase operations.</p> <p>Automatic sector erase begins after sector erase time-out from the last rising edge of \overline{WE} from the sector erase command stream and ends when the \overline{DATA} polling (DQ7) is logical 1. \overline{DATA} polling address must be performed on addresses that fall within the sectors being erased. AS29LV800 returns to read mode after sector erase unless DQ5 is set high by exceeding the time limit.</p>



Item	Description
Erase Suspend	<p>Erase Suspend allows interruption of sector erase operations to read data from or program data to a sector not being erased. Erase suspend applies only during sector erase operations, including the time-out period. Writing an Erase Suspend command during sector erase time-out results in immediate termination of the time-out period and suspension of erase operation.</p> <p>AS29LV800 ignores any commands during erase suspend other than Read/Reset, Program or Erase Resume commands. Writing the Erase Resume Command continues erase operations. Addresses are Don't Care when writing Erase Suspend or Erase Resume commands.</p> <p>AS29LV800 takes 0.2–15 μs to suspend erase operations after receiving Erase Suspend command. To determine completion of erase suspend, either check DQ6 after selecting an address of a sector not being erased, or poll RY/\overlineBY. Check DQ2 in conjunction with DQ6 to determine if a sector is being erased. AS29LV800 ignores redundant writes of Erase Suspend.</p> <p>While in erase-suspend mode, AS29LV800 allows reading data (erase-suspend-read mode) from or programming data (erase-suspend-program mode) to any sector not undergoing sector erase; these operations are treated as standard read or standard programming mode. AS29LV800 defaults to erase-suspend-read mode while an erase operation has been suspended.</p> <p>Write the Resume command 30h to continue operation of sector erase. AS29LV800 ignores redundant writes of the Resume command. AS29LV800 permits multiple suspend/resume operations during sector erase.</p>
Sector Protect	<p>When attempting to write to a protected sector, \overlineDATA polling and Toggle Bit 1 (DQ6) are activated for about <1 μs. When attempting to erase a protected sector, \overlineDATA polling and Toggle Bit 1 (DQ6) are activated for about <5 μs. In both cases, the device returns to read mode without altering the specified sectors.</p>
Ready/Busy	<p>RY/\overlineBY indicates whether an automated on-chip algorithm is in progress (RY/\overlineBY = low) or completed (RY/\overlineBY = high). The device does not accept Program/Erase commands when RY/\overlineBY = low. RY/\overlineBY = high when device is in erase suspend mode. RY/\overlineBY = high when device exceeds time limit, indicating that a program or erase operation has failed. RY/\overlineBY is an open drain output, enabling multiple RY/\overlineBY pins to be tied in parallel with a pull up resistor to V_{CC}.</p>



Status operations

$\overline{\text{DATA}}$ polling (DQ7)	Only active during automated on-chip algorithms or sector erase time outs. DQ7 reflects complement of data last written when read during the automated on-chip program algorithm (0 during erase algorithm); reflects true data when read after completion of an automated on-chip program algorithm (1 after completion of erase algorithm).
Toggle bit 1 (DQ6)	Active during automated on-chip algorithms or sector erase time outs. DQ6 toggles when $\overline{\text{CE}}$ or $\overline{\text{OE}}$ toggles, or an Erase Resume command is invoked. DQ6 is valid after the rising edge of the fourth pulse of $\overline{\text{WE}}$ during programming; after the rising edge of the sixth $\overline{\text{WE}}$ pulse during chip erase; after the last rising edge of the sector erase $\overline{\text{WE}}$ pulse for sector erase. For protected sectors, DQ6 toggles for <1 μs during program mode writes, and <5 μs during erase (if all selected sectors are protected).
Exceeding time limit (DQ5)	Indicates unsuccessful completion of program/erase operation (DQ5 = 1). $\overline{\text{DATA}}$ polling remains active. If DQ5 = 1 during chip erase, all or some sectors are defective; during byte programming or sector erase, the sector is defective (in this case, reset the device and execute a program or erase command sequence to continue working with functional sectors). Attempting to program 0 to 1 will set DQ5 = 1.
Sector erase timer (DQ3)	Checks whether sector erase timer window is open. If DQ3 = 1, erase is in progress; no commands will be accepted. If DQ3 = 0, the device will accept sector erase commands. Check DQ3 before and after each Sector Erase command to verify that the command was accepted.
Toggle bit 2 (DQ2)	During sector erase, DQ2 toggles with $\overline{\text{OE}}$ or $\overline{\text{CE}}$ only during an attempt to read a sector being erased. During chip erase, DQ2 toggles with $\overline{\text{OE}}$ or $\overline{\text{CE}}$ for all addresses. If DQ5 = 1, DQ2 toggles only at sector addresses where failure occurred, and will not toggle at other sector addresses. Use DQ2 in conjunction with DQ6 to determine whether device is in auto erase or erase suspend mode.

Write operation status

	Status	DQ7	DQ6	DQ5	DQ3	DQ2	RY/ $\overline{\text{BY}}$
Standard mode	Auto programming	$\overline{\text{DQ7}}$	Toggle	0	N/A	No toggle	0
	Program/erase in auto erase	0	Toggle	0	1	Toggle [†]	0
Erase suspend mode	Read erasing sector	1	No toggle	0	N/A	Toggle	1
	Read non-erasing sector	Data	Data	Data	Data	Data	1
	Program in erase suspend	$\overline{\text{DQ7}}$	Toggle	0	N/A	Toggle [†]	0
Exceeded time limits	Auto programming (byte)	$\overline{\text{DQ7}}$	Toggle	1	N/A	No toggle	1
	Program/erase in auto erase	0	Toggle	1	N/A	Toggle [†]	1
	Program in erase suspend (non-erase suspended sector)	$\overline{\text{DQ7}}$	Toggle	1	N/A	No toggle	1

DQ2 toggles when an erase-suspended sector is read repeatedly.

DQ6 toggles when any address is read repeatedly.

DQ2 = 1 if byte address being programmed is read during erase-suspend program mode.

[†]DQ2 toggles when the read address applied points to a sector which is undergoing erase, suspended erase, or a failure to erase.



Automated on-chip programming algorithm

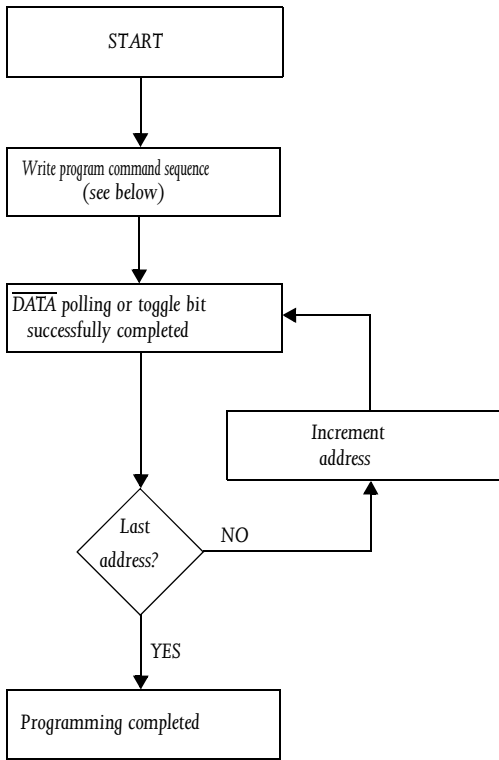

Program command sequence
×16 mode (address/data):

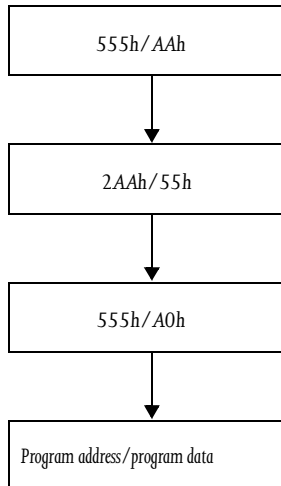

Automated on-chip erase algorithm

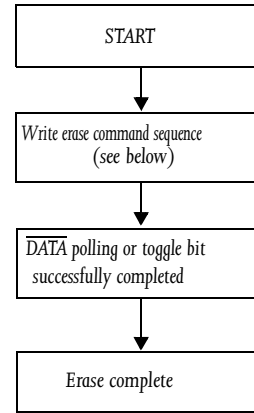

Chip erase command sequence
×16 mode (address/data):

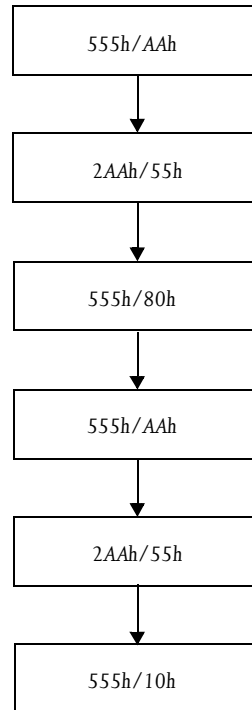

Individual sector/multiple sector
erase command sequence
×16 mode (address/data):

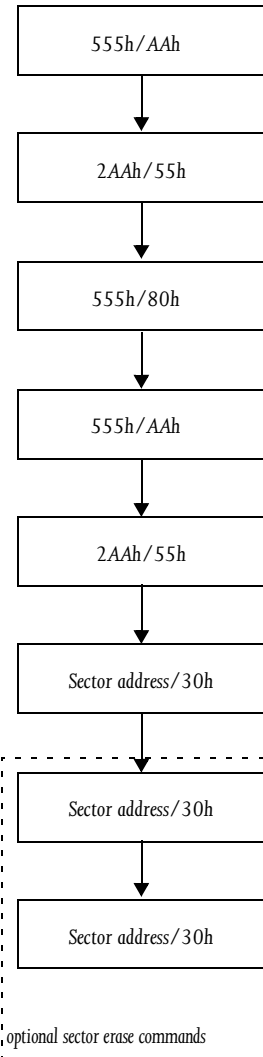

† The system software should check the status of DQ3 prior to and following each subsequent sector erase command to ensure command completion. The device may not have accepted the command if DQ3 is high on second status check.



Programming using unlock bypass command

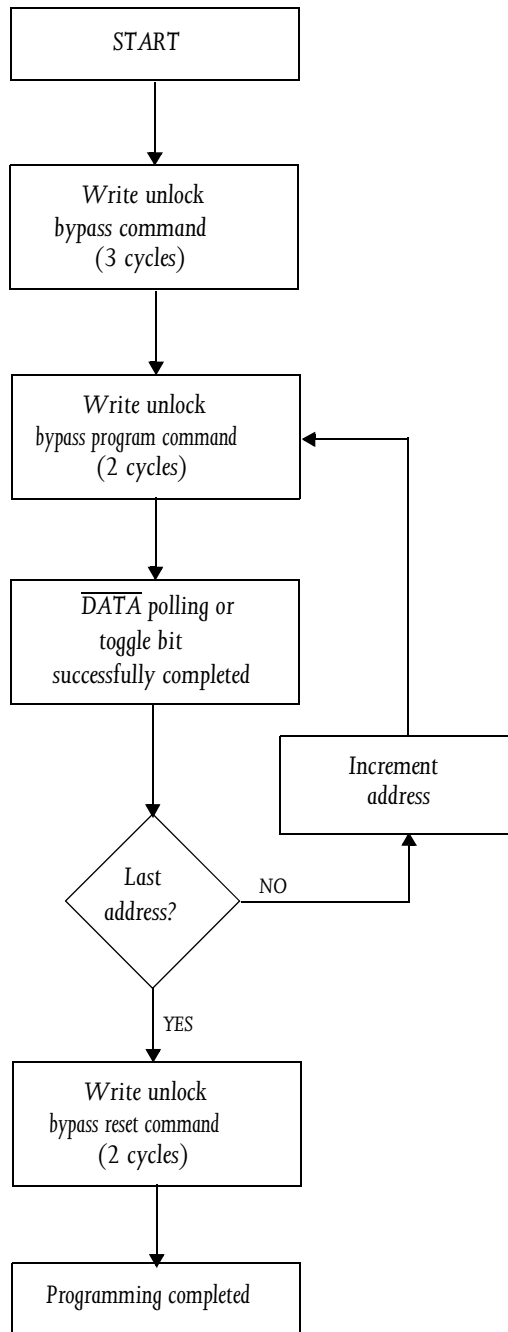

Unlock bypass command sequence
x16 mode (address/data)

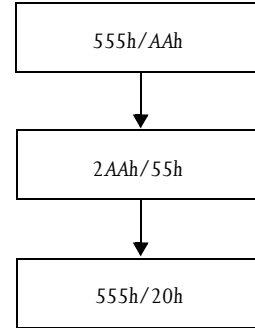

Unlock bypass program command sequence
x16 mode (address/data)

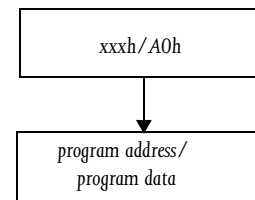

Unlock bypass reset command sequence
x16 mode (address/data)

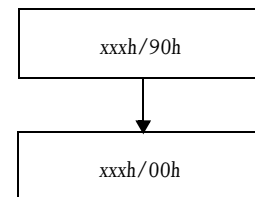



DATA polling algorithm

Toggle bit algorithm

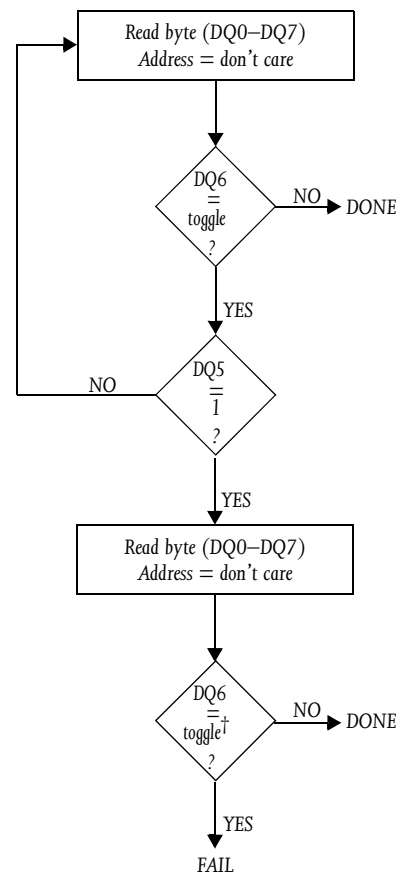
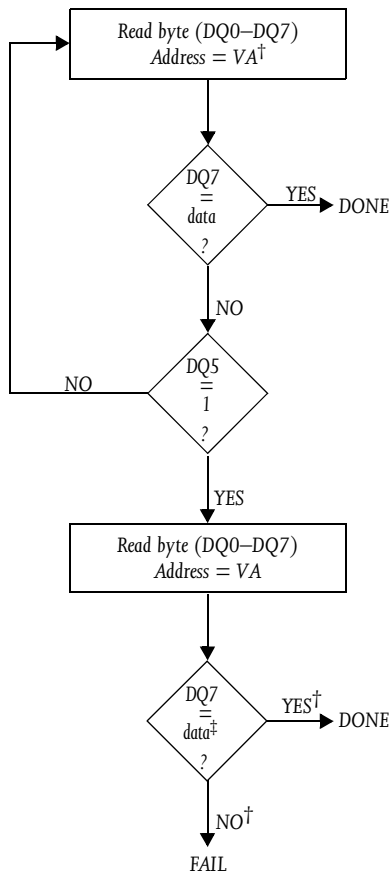

† VA = Byte address for programming. VA = any of the sector addresses within the sector being erased during Sector Erase. VA = valid address equals any non-protected sector group address during Chip Erase.

‡ DQ7 rechecked even if DQ5 = 1 because DQ5 and DQ7 may not change simultaneously.

‡DQ6 rechecked even if DQ5 = 1 because DQ6 may stop toggling when DQ5 changes to 1.



Sector protect algorithm

Sector unprotect algorithm

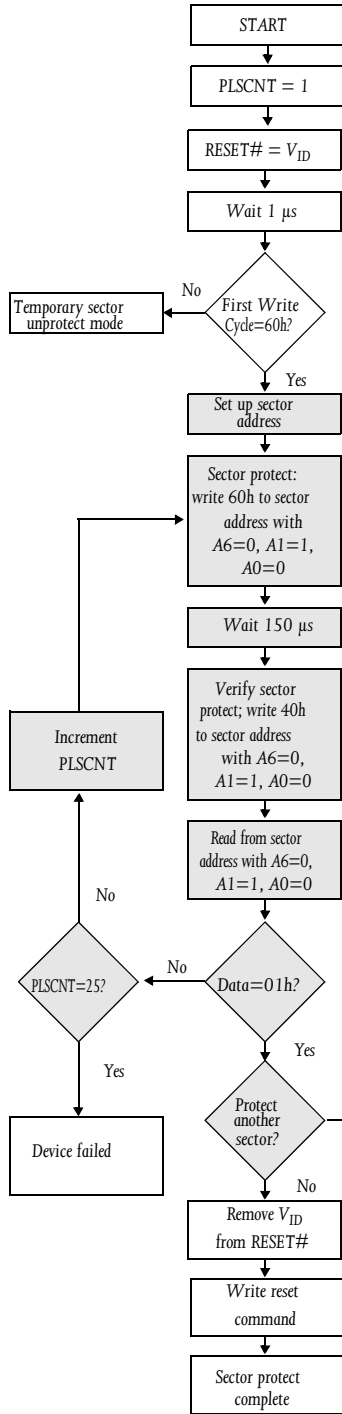

Protect all sectors:
The shaded portion of the sector protect algorithm must be initiated for all unprotected sectors before calling the sector unprotect

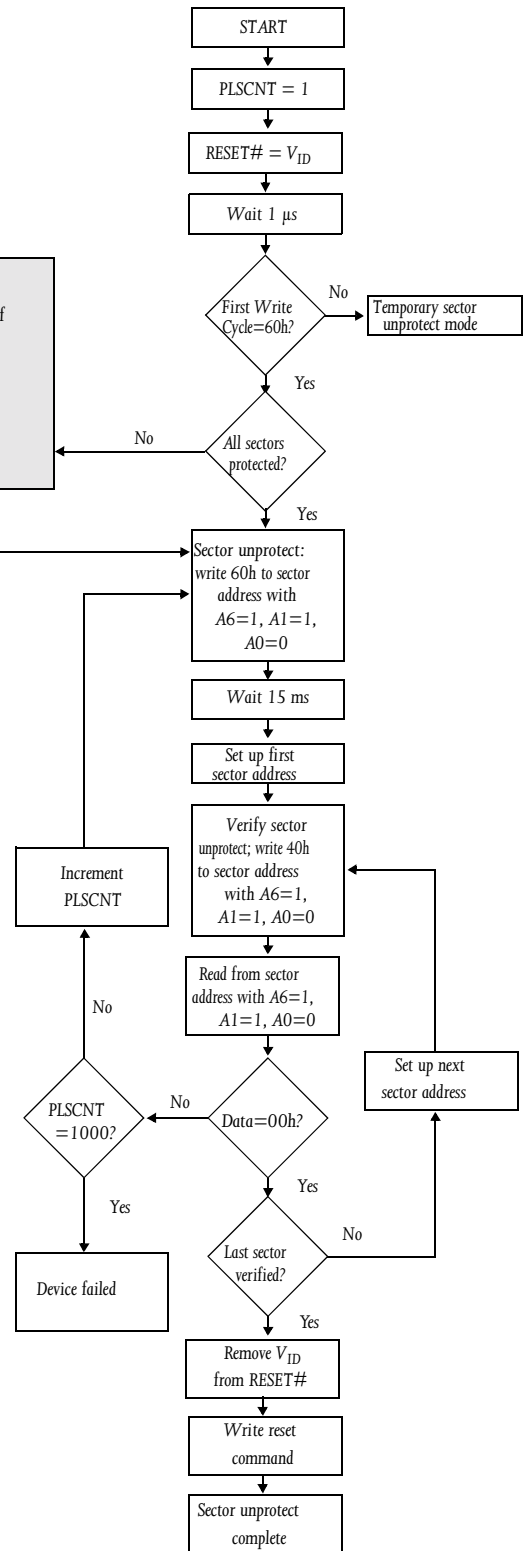



DC electrical characteristics

 $V_{CC} = 2.7\text{--}3.6\text{V}$

Parameter	Symbol	Test conditions	Min	Max	Unit
Input load current	I_{LI}	$V_{IN} = V_{SS}$ to V_{CC} , $V_{CC} = V_{CC\ MAX}$	-	± 1	μA
A9 Input load current	I_{LIT}	$V_{CC} = V_{CC\ MAX}$, A9 = 10V		35	μA
Output leakage current	I_{LO}	$V_{OUT} = V_{SS}$ to V_{CC} , $V_{CC} = V_{CC\ MAX}$	-	± 1	μA
Active current, read @ 5MHz	I_{CC1}	$\overline{CE} = V_{IL}$, $\overline{OE} = V_{IH}$	-	20	mA
Active current, program/erase	I_{CC2}	$\overline{CE} = V_{IL}$, $\overline{OE} = V_{IH}$	-	100	mA
Automatic sleep mode*	I_{CC3}	$\overline{CE} = V_{IL}$, $\overline{OE} = V_{IH}$; $V_{IL} = 0.3\text{V}$, $V_{IH} = V_{CC} - 0.3\text{V}$	-	5	μA
Standby current	I_{SB}	$\overline{CE} = V_{CC} - 0.3\text{V}$, $\overline{RESET} = V_{CC} - .3\text{V}$	-	5	μA
Deep power down current ³	I_{PD}	$\overline{RESET} = 0.3\text{V}$	-	5	μA
Input low voltage	V_{IL}		-0.5	0.8	V
Input high voltage	V_{IH}		$0.7 \times V_{CC}$	$V_{CC} + 0.3$	V
Output low voltage	V_{OL}	$I_{OL} = 4.0\text{mA}$, $V_{CC} = V_{CC\ MIN}$	-	0.45	V
Output high voltage	V_{OH}	$I_{OH} = -2.0\text{mA}$, $V_{CC} = V_{CC\ MIN}$	$0.85 \times V_{CC}$	-	V
Low V_{CC} lock out voltage	V_{LKO}		1.5	-	V
Input HV select voltage	V_{ID}		9	11	V

* Automatic sleep mode enables the deep power down mode when addresses are stable for 150 ns. Typical sleep mode current is 200 nA.



AC parameters — read cycle

JEDEC Symbol	Std Symbol	Parameter	-70R		-80		-90		-120		Unit
			Min	Max	Min	Max	Min	Max	Min	Max	
t_{AVAV}	t_{RC}	Read cycle time	70	-	80	-	90	-	120	-	ns
t_{AVQV}	t_{ACC}	Address to output delay	-	70	-	80	-	90	-	120	ns
t_{ELQV}	t_{CE}	Chip enable to output	-	70	-	80	-	90	-	120	ns
t_{GLQV}	t_{OE}	Output enable to output	-	30	-	30	-	35	-	50	ns
	t_{OES}	Output enable setup time	0	-	0	-	0	-	0	-	ns
t_{EHQZ}	t_{DF}	Chip enable to output High Z	-	20	-	20	-	30	-	30	ns
t_{GHQZ}	t_{DF}	Output enable to output High Z	-	20	-	20	-	30	-	30	ns
t_{AXQX}	t_{OH}	Output hold time from addresses, first occurrence of \overline{CE} or \overline{OE}	0	-	0	-	0	-	0	-	ns
	t_{OEH}	Output enable hold time: Read Toggle and data polling	10	-	10	-	10	-	10	-	ns
t_{PHQV}	t_{RH}	\overline{RESET} high to output delay	-	50	-	50	-	50	-	50	ns
	t_{READY}	\overline{RESET} pin low to read mode	-	10	-	10	-	10	-	10	μ s
	t_{RP}	\overline{RESET} pulse	500	-	500	-	500	-	500	-	ns

Read waveform

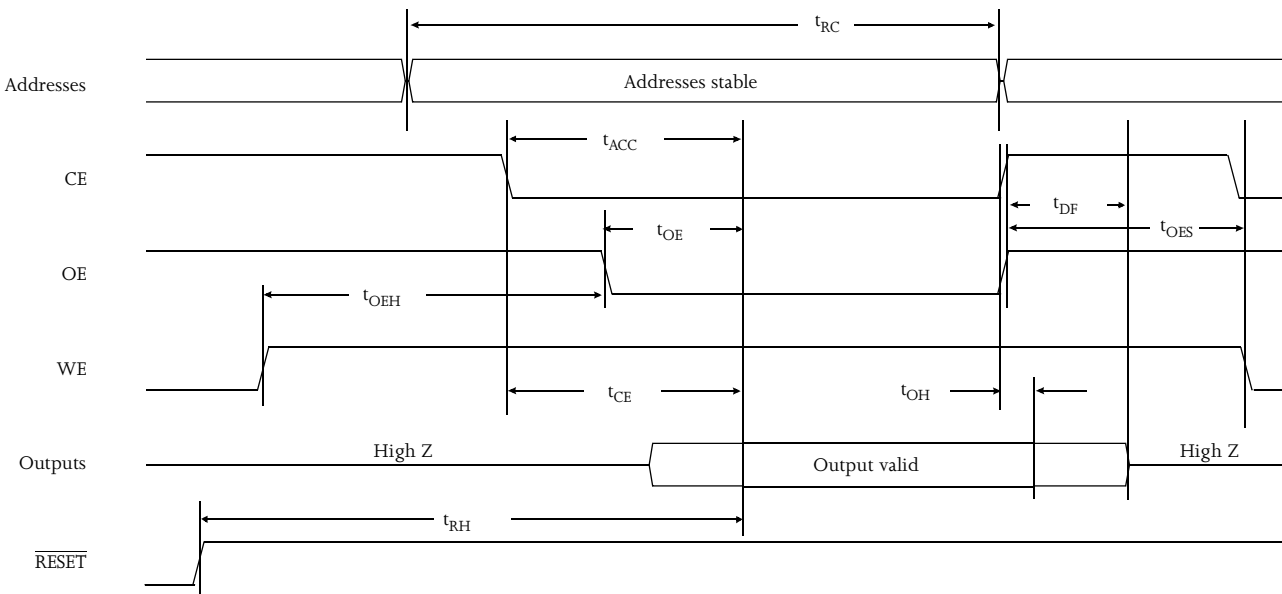



AC parameters — write cycle

\overline{WE} controlled

JEDEC Symbol	Std Symbol	Parameter	-70R		-80		-90		-120		Unit
			Min	Max	Min	Max	Min	Max	Min	Max	
t_{AVAV}	t_{WC}	Write cycle time	70	-	80	-	90	-	120	-	ns
t_{AVWL}	t_{AS}	Address setup time	0	-	0	-	0	-	0	-	ns
t_{WLAX}	t_{AH}	Address hold time	45	-	45	-	45	-	50	-	ns
t_{DVWH}	t_{DS}	Data setup time	35	-	35	-	45	-	50	-	ns
t_{WHDX}	t_{DH}	Data hold time	0	-	0	-	0	-	0	-	ns
t_{GHWL}	t_{GHWL}	Read recover time before write	0	-	0	-	0	-	0	-	ns
t_{ELWL}	t_{CS}	CE setup time	0	-	0	-	0	-	0	-	ns
t_{WHEH}	t_{CH}	CE hold time	0	-	0	-	0	-	0	-	ns
t_{WLWH}	t_{WP}	Write pulse width	35	-	35	-	35	-	50	-	ns
t_{WHWL}	t_{WPH}	Write pulse width high	30	-	30	-	30	-	30	-	ns

Write waveform

\overline{WE} controlled

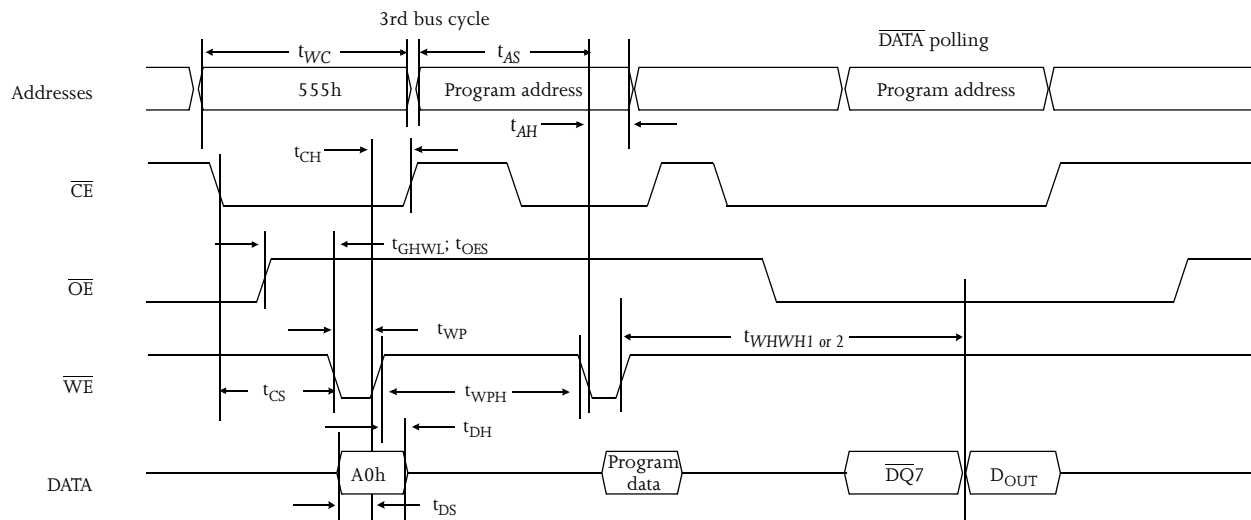



AC parameters — write cycle 2

\overline{CE} controlled

JEDEC Symbol	Std Symbol	Parameter	-70R		-80		-90		-120		Unit
			Min	Max	Min	Max	Min	Max	Min	Max	
t_{AVAV}	t_{WC}	Write cycle time	70	-	80	-	90	-	120	-	ns
t_{AVEL}	t_{AS}	Address setup time	0	-	0	-	0	-	0	-	ns
t_{ELAX}	t_{AH}	Address hold time	45	-	45	-	45	-	50	-	ns
t_{DVEH}	t_{DS}	Data setup time	35	-	35	-	45	-	50	-	ns
t_{EHDX}	t_{DH}	Data hold time	0	-	0	-	0	-	0	-	ns
t_{GHXL}	t_{GHXL}	Read recover time before write	0	-	0	-	0	-	0	-	ns
t_{WLEL}	t_{WS}	WE setup time	0	-	0	-	0	-	0	-	ns
t_{EHWH}	t_{WH}	WE hold time	0	-	0	-	0	-	0	-	ns
t_{ELEH}	t_{CP}	CE pulse width	35	-	35	-	35	-	50	-	ns
t_{EHEL}	t_{CPH}	CE pulse width high	30	-	30	-	30	-	30	-	ns

Write waveform 2

\overline{CE} controlled

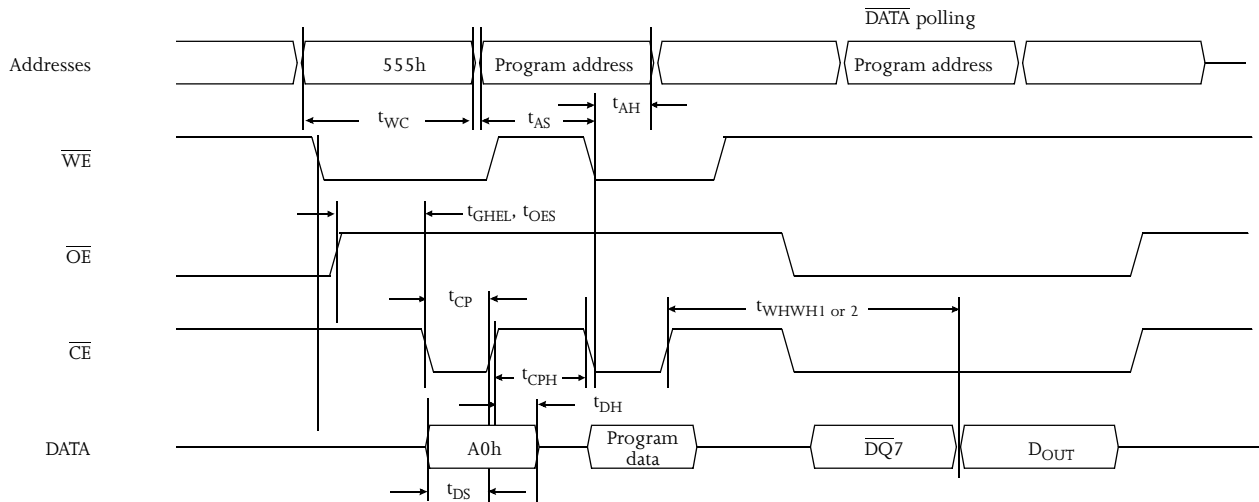



AC parameters — temporary sector unprotect

-70R/80/90/120

JEDEC Symbol	Std Symbol	Parameter	Min	Max	Unit
t _{VIDR}	V _{ID}	V _{ID} rise and fall time	500	-	ns
t _{RSP}	RESET	RESET setup time for temporary sector unprotect	4	-	μs

Temporary sector unprotect waveform

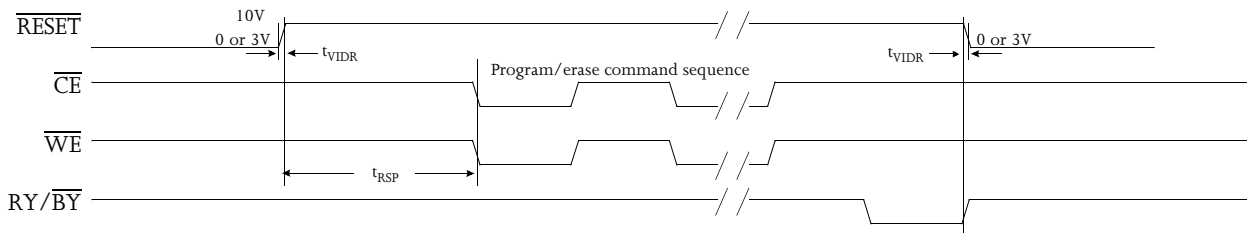

AC parameters — $\overline{\text{RESET}}$

-70R/80/90/120

JEDEC Symbol	Std Symbol	Parameter	Min	Max	Unit
t _{RP}	RESET	RESET pulse	500	-	ns
t _{RH}	RESET	RESET High time before Read	-	50	ns
t _{READY}	RESET	RESET Low to Read mode	-	10	μs

$\overline{\text{RESET}}$ waveform

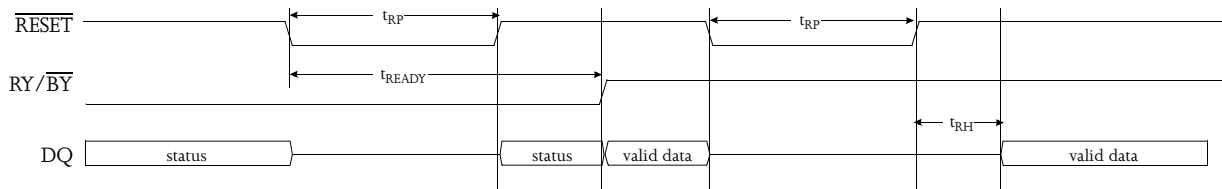

Erase waveform

×16 mode

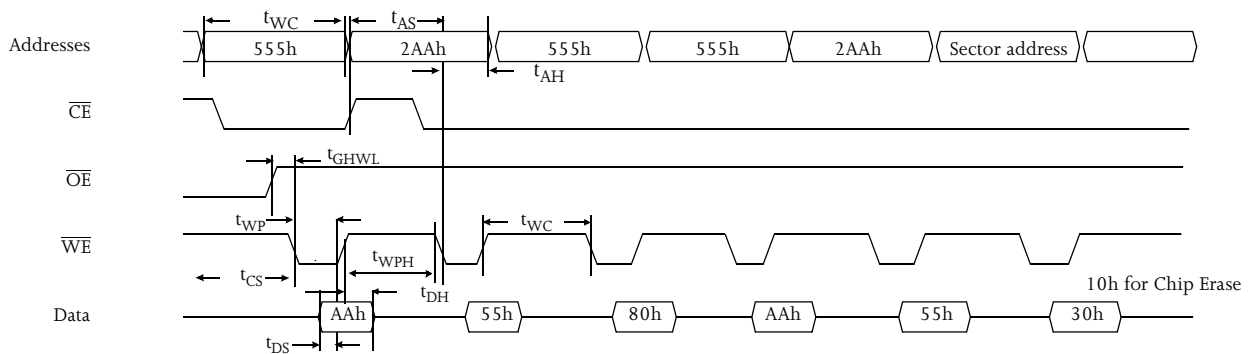



AC Parameters — READY/BUSY

-70R/80/90/120

JEDEC Symbol	Std Symbol	Parameter	Min	Max	Unit
-	t_{VCS}	V_{CC} setup time	50	-	μs
-	t_{RB}	Recovery time from $\overline{RY}/\overline{BY}$	0	-	ns
-	t_{BUSY}	Program/erase valid to $\overline{RY}/\overline{BY}$ delay	90	-	ns

$\overline{RY}/\overline{BY}$ waveform

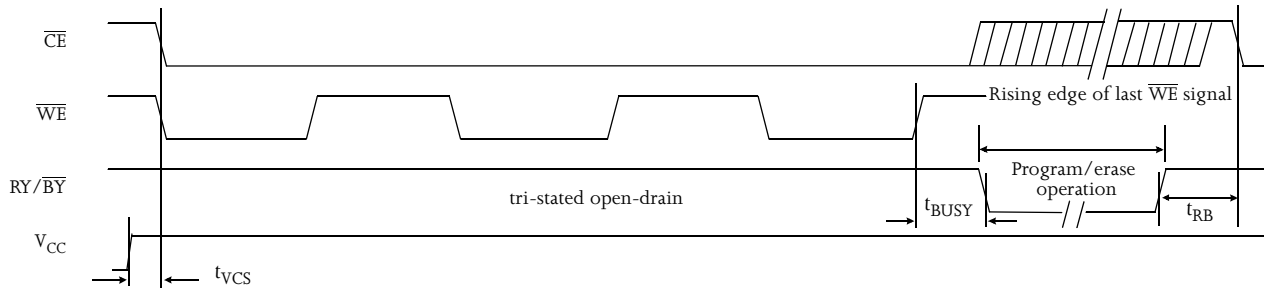

\overline{DATA} polling waveform

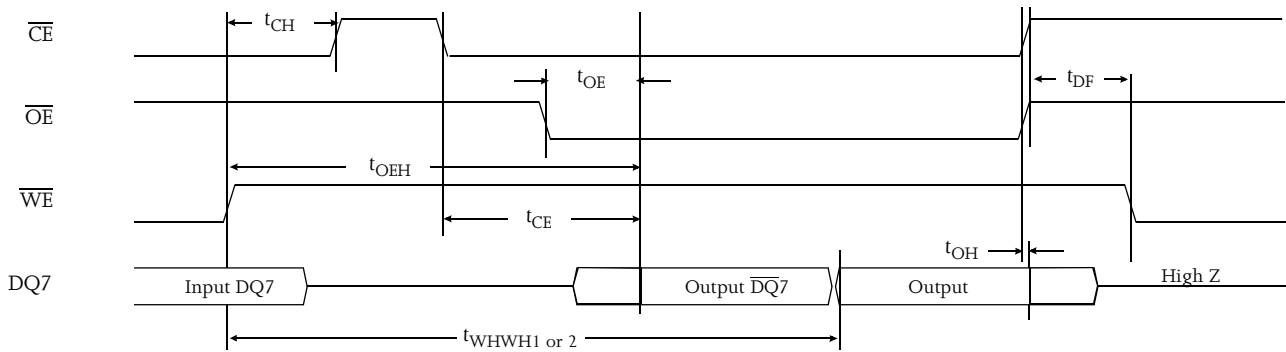

Toggle bit waveform

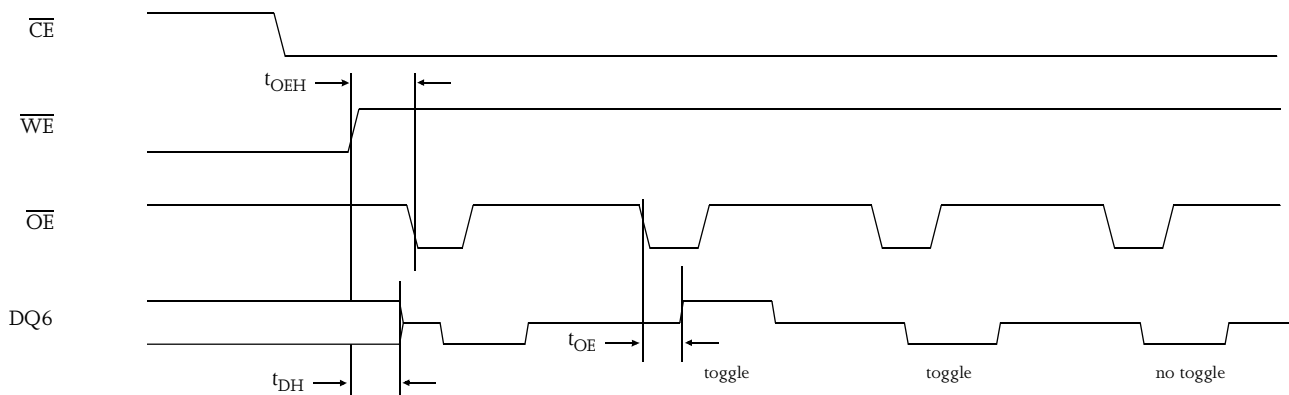



Word/byte configuration

-70R/80/90/120

JEDEC Symbol	Std Symbol	Parameter	Min	Max	Unit
-	t_{ELFL}/t_{ELFH}	CE to BYTE switching Low or High	-	10	ns
-	t_{FLQZ}	BYTE switching Low to output High-Z	-	30	ns
-	t_{FHQZ}	BYTE switching High to output Active	80	-	ns

BYTE read waveform

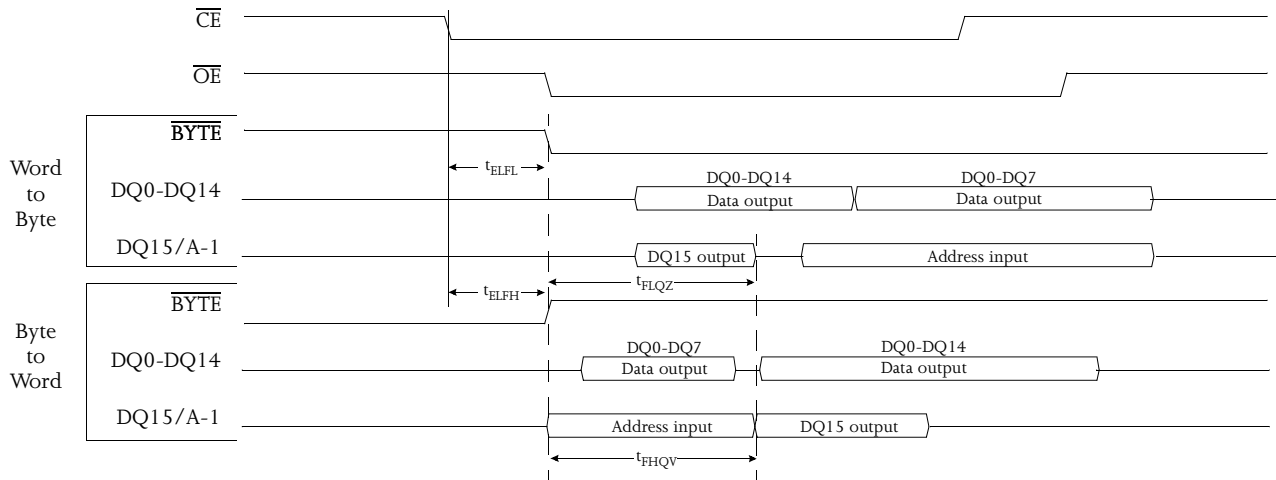

BYTE write waveform

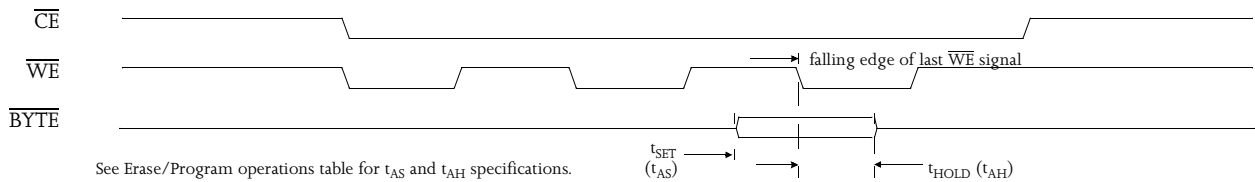

Sector protect/unprotect

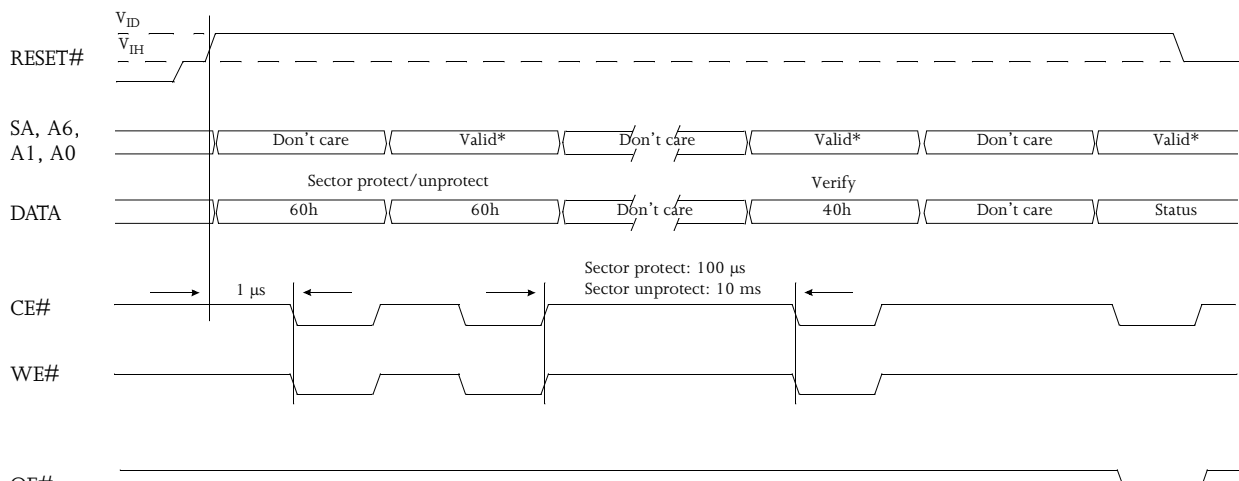



AC test conditions

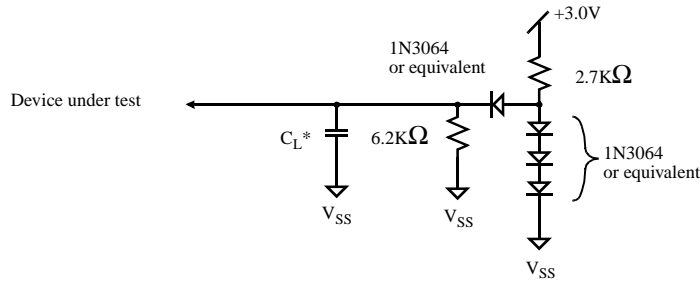

Test specifications

Test Condition	-70R,-80	-90, -120	Unit
Output Load	1 TTL gate		
Output Load Capacitance C_L (including jig capacitance)	30	100	pF
Input Rise and Fall Times	5		ns
Input Pulse Levels	0.0-3.0		V
Input timing measurement reference levels	1.5		V
Output timing measurement reference levels	1.5		V

Erase and programming performance

Parameter	Limits			Unit	
	Min	Typical	Max		
Sector erase and verify-1 time (excludes 00h programming prior to erase)	-	1.0	15	sec	
Programming time	Byte	-	10	300	μ s
	Word	-	15	360	μ s
Chip programming time	-	7.2	27	sec	
Erase/program cycles*	-	100,000	-	cycles	

* Erase/program cycle test is not verified on each shipped unit.

Latchup tolerance

Parameter	Min	Max	Unit
Input voltage with respect to V_{SS} on A9, OE, and RESET pin	-1.0	+12.0	V
Input voltage with respect to V_{SS} on all DQ, address, and control pins	-0.5	$V_{CC}+0.5$	V
Current	-100	+100	mA

Includes all pins except V_{CC} . Test conditions: $V_{CC} = 3.0V$, one pin at a time.



Recommended operating conditions

Parameter	Comments	Symbol	Min	Max	Unit
Supply voltage	For full voltage range	V_{CC}	+2.7	+3.6	V
	For regulated voltage range	V_{CC}	+3.0	+3.6	V
Input voltage		V_{SS}	0	0	V
		V_{IH}	1.9	$V_{CC} + 0.3$	V
		V_{IL}	-0.5	0.8	V

Absolute maximum ratings

Parameter	Symbol	Min	Max	Unit
Input voltage (Input or DQ pin)	V_{IN}	-0.5	$V_{CC} + 0.5$	V
Input voltage (A9 pin, \overline{OE} , \overline{RESET})	V_{IN}	-0.5	+12.5	V
Power supply voltage	V_{CC}	-0.5	+4.0	V
Operating temperature	T_{OPR}	-55	+125	°C
Storage temperature (plastic)	T_{STG}	-65	+150	°C
Short circuit output current	I_{OUT}	-	150	mA

Stresses greater than those listed under *Absolute Maximum Ratings* may cause permanent damage to the device. This is a stress rating only and functional operation of the device at these or any other conditions outside those indicated in the operational sections of this specification is not implied. Exposure to absolute maximum rating conditions for extended periods may affect reliability.

TSOP pin capacitance

Symbol	Parameter	Test setup	Typ	Max	Unit
C_{IN}	Input capacitance	$V_{IN} = 0$	6	7.5	pF
C_{OUT}	Output capacitance	$V_{OUT} = 0$	8.5	12	pF
C_{IN2}	Control pin capacitance	$V_{IN} = 0$	8	10	pF

SO pin capacitance

Symbol	Parameter	Test setup	Typ	Max	Unit
C_{IN}	Input capacitance	$V_{IN} = 0$	6	7.5	pF
C_{OUT}	Output capacitance	$V_{OUT} = 0$	8.5	12	pF
C_{IN2}	Control pin capacitance	$V_{IN} = 0$	8	10	pF

Data retention

Parameter	Temp.(°C)	Min	Unit
Minimum pattern data retention time	150°	10	years
	125°	20	years



Thin small outline package (TSOP-I)

Package dimensions

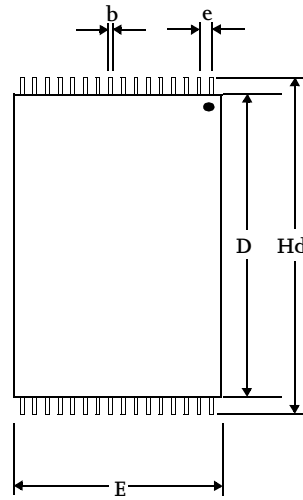
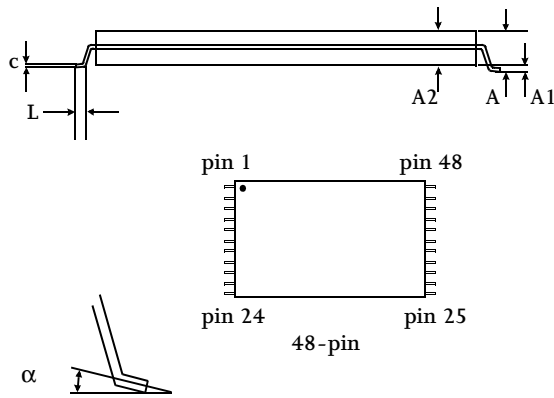

	48-pin 12x20	
	Min	Max
A	—	1.27
A1	0.05	0.15
A2	0.95	1.05
b	0.17	0.27
c	0.15 nominal	
D	18.20	18.60
e	0.50 nominal	
E	11.90	12.10
Hd	19.80	20.20
L	0.50	0.70
α	0°	5°

Small Outline Plastic (SO)

Package dimensions

JEDEC MO - 175 AA
44-pin SO

	Min (mm)	Max (mm)
A	—	3.1
A1	0.05	—
A2	2.5	2.9
b	0.25	0.45
c	0.09	0.25
d	28.0	28.4
e	12.4	12.8
E	1.27 (typical)	
He	16.05 (typical)	
l	0.73	1.3

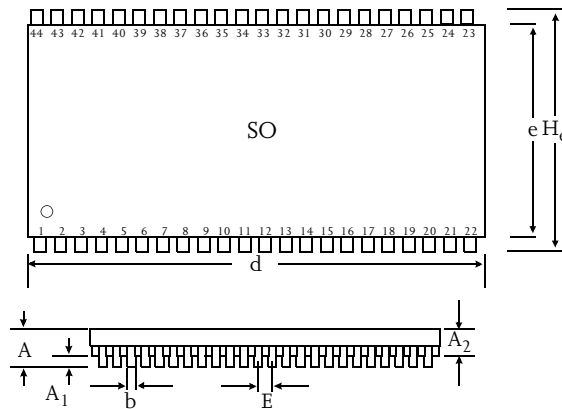



AS29LV800 ordering codes

Package \ Access Time	70 ns (commercial/ industrial)	80 ns (commercial/ industrial)	90 ns (commercial/ industrial)	120 ns (commercial/ industrial)
TSOP, 12x20 mm, 48-pin Top boot configuration	AS29LV800T-70RTC AS29LV800T-70RTI	AS29LV800T-80TC AS29LV800T-80TI	AS29LV800T-90TC AS29LV800T-90TI	AS29LV800T-120TC AS29LV800T-120TI
TSOP, 12x20 mm, 48-pin Bottom boot configuration	AS29LV800B-70RTC AS29LV800B-70RTI	AS29LV800B-80TC AS29LV800B-80TI	AS29LV800B-90TC AS29LV800B-90TI	AS29LV800B-120TC AS29LV800B-120TI
SO, 13.3 mm, 44-pin* Top boot configuration	AS29LV800T-70RSC AS29LV800T-70RSI	AS29LV800T-80SC AS29LV800T-80SI	AS29LV800T-90SC AS29LV800T-90SI	AS29LV800T-120SC AS29LV800T-120SI
SO, 13.3 mm, 44-pin Bottom boot configuration	AS29LV800B-70RSC AS29LV800B-70RSI	AS29LV800B-80SC AS29LV800B-80SI	AS29LV800B-90SC AS29LV800B-90SI	AS29LV800B-120SC AS29LV800B-120SI

* Shaded area indicates advanced information. Availability of SO package is TBD.

AS29LV800 part numbering system

AS29LV	800	X	-XXX	X	X	X
3V Flash EEPROM prefix	Device number	T= Top boot configuration B= Bottom boot configuration	Address access time*	Package: S = SO T = TSOP	Temperature range: C = Commercial: 0°C to 70°C I = Industrial: -40°C to 85°C	Options: B = Burn-in H = High I _{SB} (<1mA) Blank= Standard

* Suffix "R" denotes regulated voltage range.

© Copyright Alliance Semiconductor Corporation. All rights reserved. Our three-point logo, our name and Intelliwatt are trademarks or registered trademarks of Alliance. All other brand and product names may be the trademarks of their respective companies. Alliance reserves the right to make changes to this document and its products at any time without notice. Alliance assumes no responsibility for any errors that may appear in this document. The data contained herein represents Alliance's best data and/or estimates at the time of issuance. Alliance reserves the right to change or correct this data at any time, without notice. If the product described herein is under development, significant changes to these specifications are possible. The information in this product data sheet is intended to be general descriptive information for potential customers and users, and is not intended to operate as, or provide, any guarantee or warranty to any user or customer. Alliance does not assume any responsibility or liability arising out of the application or use of any product described herein, and disclaims any express or implied warranties related to the sale and/or use of Alliance products including liability or warranties related to fitness for a particular purpose, merchantability, or infringement of any intellectual property rights, except as expressly agreed to in Alliance's Terms and Conditions of Sale (which are available from Alliance). All sales of Alliance products are made exclusively according to Alliance's Terms and Conditions of Sale. The purchase of products from Alliance does not convey a license under any patent rights, copyrights, mask works rights, trademarks, or any other intellectual property rights of Alliance or third parties. Alliance does not authorize its products for use as critical components in life-supporting systems where a malfunction or failure may reasonably be expected to result in significant injury to the user, and the inclusion of Alliance products in such life-supporting systems implies that the manufacturer assumes all risk of such use and agrees to indemnify Alliance against all claims arising from such use.