

## DUAL FULL-BRIDGE PWM MOTOR DRIVER

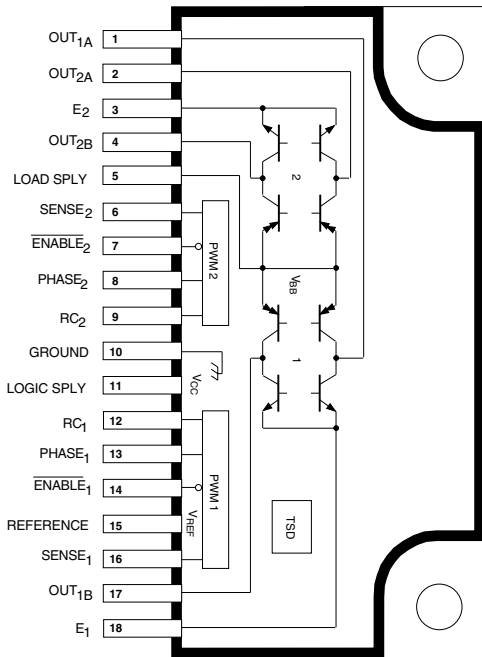

Dwg. PP-051

### ABSOLUTE MAXIMUM RATINGS at $T_J \leq +150^\circ\text{C}$

Motor Supply Voltage, $V_{BB}$ .....	<b>45 V</b>
Output Current, $I_{OUT}$ ( $t_w \leq 20 \mu\text{s}$ ) ..	<b><math>\pm 1.75 \text{ A}</math></b>
(Continuous) .....	<b><math>\pm 1.5 \text{ A}</math></b>
Logic Supply Voltage, $V_{CC}$ .....	<b>7.0 V</b>
Logic Input Voltage Range, $V_{IN}$ .....	<b>-0.3 V to +7.0 V</b>
Output Emitter Voltage, $V_E$ .....	<b>1.5 V</b>
Package Power Dissipation, $P_D$ .....	<b>See Graph</b>
Operating Temperature Range, $T_A$ .....	<b><math>-20^\circ\text{C}</math> to <math>+85^\circ\text{C}</math></b>
Storage Temperature Range, $T_S$ .....	<b><math>-40^\circ\text{C}</math> to <math>+150^\circ\text{C}</math></b>

Output current rating may be limited by duty cycle, ambient temperature, and heat sinking. Under any set of conditions, do not exceed the specified peak current rating or a junction temperature of  $+150^\circ\text{C}$ .

The A2918SWH and A2918SWV motor drivers are designed to drive both windings of a bipolar stepper motor or bidirectionally control two dc motors. All bridges are capable of sustaining 45 V and include internal pulse-width modulation (PWM) control of the output current to 1.5 A.

For PWM current control, the maximum output current is determined by the user's selection of a reference voltage and sensing resistor. A PHASE input to each bridge determines load current direction. Active low ENABLE inputs control the four drivers in each bridge.

The bridges include both ground clamp and flyback diodes for protection against inductive transients. Internally generated delays prevent cross-over currents when switching current direction. Special power-up sequencing is not required. Thermal protection circuitry disables the outputs if the chip temperature exceeds safe operating limits.

The A2918SWH/V are supplied in an 18-lead power-tab package with staggered lead forming. The tab is internally insulated from the device and requires no external isolation. The A2918SWH/V are available for operation from  $-40^\circ\text{C}$  to  $+85^\circ\text{C}$ . To order, change the suffix from 'S-' to 'E-'. These devices are also available on special order for operation to  $+125^\circ\text{C}$ .

### FEATURES

- $\pm 1.5 \text{ A}$  Continuous Output Current
- 45 V Output Sustaining Voltage
- Internal PWM Current Control
- Low Output Saturation Voltage
- Internal Clamp Diodes
- Internal Thermal Shutdown Circuitry
- Similar to Dual PBL3718 or Dual PBL3770

Always order by complete part number:

Part Number	Application
A2918SWH	For Horizontal Mount
A2918SWV	For Vertical Mount

# 2918 DUAL FULL-BRIDGE PWM MOTOR DRIVER

## FUNCTIONAL BLOCK DIAGRAM

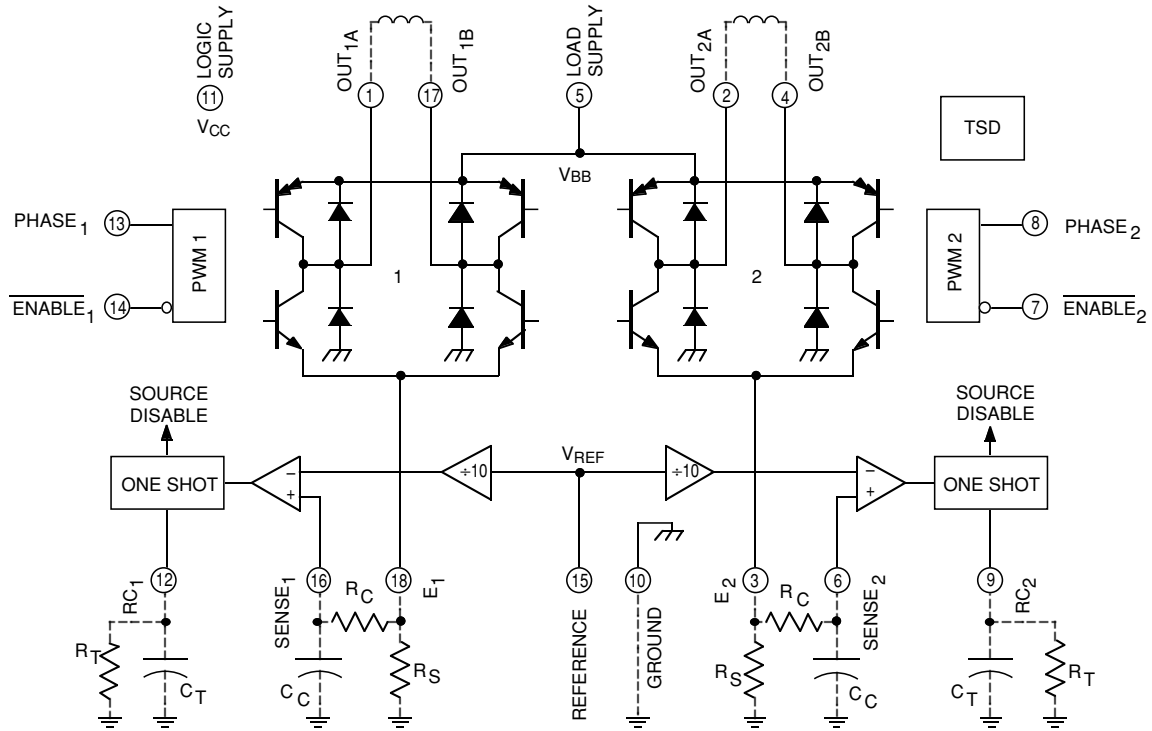

Dwg. FP-033

## TRUTH TABLE

Enable	Phase	Out <sub>A</sub>	Out <sub>B</sub>
L	H	H	L
L	L	L	H
H	X	Z	Z

X = Don't care

Z = High impedance

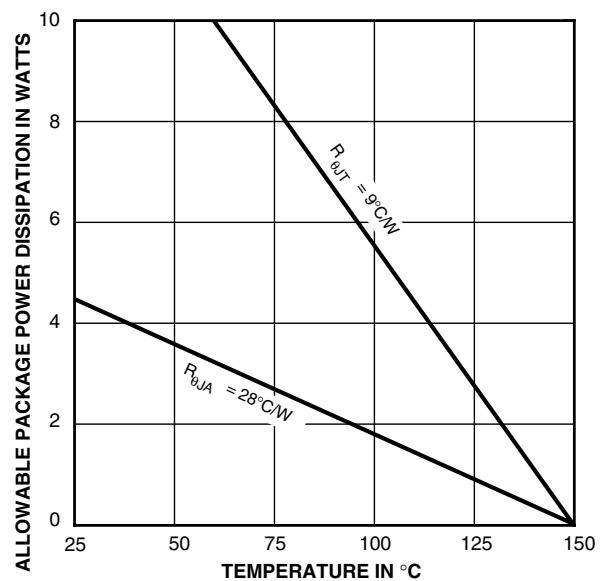

Dwg. GP-043



115 Northeast Cutoff, Box 15036  
Worcester, Massachusetts 01615-0036 (508) 853-5000  
Copyright © 1991, 1993, Allegro MicroSystems, Inc.

# 2918 DUAL FULL-BRIDGE PWM MOTOR DRIVER

**ELECTRICAL CHARACTERISTICS at  $T_A = +25^\circ\text{C}$ ,  $V_{BB} = 45\text{ V}$ ,  $V_{CC} = 4.75\text{ V to } 5.25\text{ V}$ ,  $V_{REF} = 5.0\text{ V}$  (unless otherwise noted).**

Characteristic	Symbol	Test Conditions	Limits			Units
			Min.	Typ.	Max.	
<b>Output Drivers (OUT<sub>A</sub> or OUT<sub>B</sub>)</b>						
Motor Supply Range	$V_{BB}$		10	—	45	V
Output Leakage Current	$I_{CEX}$	$V_{OUT} = V_{BB}$	—	<1.0	50	$\mu\text{A}$
		$V_{OUT} = 0$	—	<-1.0	-50	$\mu\text{A}$
Output Sustaining Voltage	$V_{CE(sus)}$	$I_{OUT} = \pm 1.5\text{ A}$ , $L = 3.0\text{ mH}$	45	—	—	V
Output Saturation Voltage	$V_{CE(SAT)}$	Sink Driver, $I_{OUT} = +1.0\text{ A}$	—	0.7	0.8	V
		Sink Driver, $I_{OUT} = +1.5\text{ A}$	—	0.9	1.1	V
		Source Driver, $I_{OUT} = -1.0\text{ A}$	—	1.8	2.0	V
		Source Driver, $I_{OUT} = -1.5\text{ A}$	—	1.9	2.2	V
Clamp Diode Leakage Current	$I_R$	$V_R = 45\text{ V}$	—	<1.0	50	$\mu\text{A}$
Clamp Diode Forward Voltage	$V_F$	$I_F = 1.5\text{ A}$	—	1.6	2.0	V
Driver Supply Current	$I_{BB(ON)}$	Both Bridges ON, No Load	—	12	15	mA
	$I_{BB(OFF)}$	Both Bridges OFF	—	8.0	10	mA

### Control Logic

Input Voltage	$V_{IN(1)}$	All Inputs	2.4	—	—	V
	$V_{IN(0)}$	All Inputs	—	—	0.8	V
Input Current	$I_{IN(1)}$	$V_{IN} = 2.4\text{ V}$	—	<1.0	20	$\mu\text{A}$
	$I_{IN(0)}$	$V_{IN} = 0.8\text{ V}$	—	-3.0	-200	$\mu\text{A}$
Reference Voltage Range	$V_{REF}$	Operating	1.5	—	$V_{CC}$	V
Current Limit Threshold	$V_{REF}/V_{SENSE}$	At Trip Point	9.5	10	10.5	—
Thermal Shutdown Temp.	$T_J$		—	170	—	$^\circ\text{C}$
Total Logic Supply Current	$I_{CC(ON)}$	$V_{EN} = 0.8\text{ V}$ , No Load	—	105	140	mA
	$I_{CC(OFF)}$	$V_{EN} = 2.4\text{ V}$ , No Load	—	10	12	mA

Negative current is defined as coming out of (sourcing) the specified device pin.

Typical Data is for design information only.

# 2918 DUAL FULL-BRIDGE PWM MOTOR DRIVER

## PWM OUTPUT CURRENT WAVEFORM

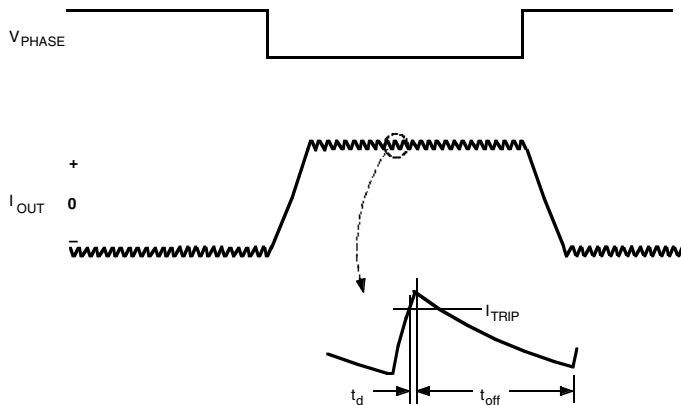

Dwg. WM-003-1A

## APPLICATIONS INFORMATION

### PWM Current Control

The A2918SWH/V dual bridges are designed to drive both windings of a bipolar stepper motor. Output current is sensed and controlled independently in each bridge by an external sense resistor ( $R_S$ ), an internal comparator, and an internal monostable multivibrator.

When the bridge is turned ON, current increases in the motor winding and it is sensed by  $R_S$  until the sense voltage ( $V_{SENSE}$ ) reaches the level set at the comparator's input:

$$I_{TRIP} = V_{REF}/10 R_S$$

The comparator then triggers the monostable which turns OFF the source driver of the bridge. The actual load current peak will be slightly higher than the trip point (especially for low-inductance loads) because of internal logic and switching delays. This delay ( $t_d$ ) is 2  $\mu$ s typically. After turn-off, the motor current decays, circulating through the ground clamp diode and sink transistor. The source driver's OFF time  $t_{off}$ , and therefore the magnitude of the current decrease, is determined by the monostable's external RC timing components, where  $t_{off} = R_T C_T$  within the range of 20 k $\Omega$  to 100 k $\Omega$  and 200 pF to 500 pF.

When the source driver is re-enabled, the winding current (the sense voltage) again is allowed to rise to the comparator's threshold. This cycle repeats itself, maintaining the average motor winding current at the desired level.

Special circuitry has been included to prevent runaway current control when  $t_{off}$  is set too short. This circuitry prevents the source driver from being re-enabled until the load current has decayed to below the  $I_{TRIP}$  level.

Loads with high distributed capacitances may result in high turn-ON current peaks. This peak, appearing across  $R_S$ , will attempt to trip the comparator, resulting in possible erroneous current control or high-frequency oscillations. An external  $R_C C_C$  low-pass filter may be used to delay the action of the comparator, and thus ignore turn-on spikes.

# 2918 DUAL FULL-BRIDGE PWM MOTOR DRIVER

## General

To avoid excessive voltage spikes on the LOAD SUPPLY pin ( $V_{BB}$ ), a large-value capacitor ( $\geq 47 \mu\text{F}$ ) should be connected from  $V_{BB}$  to the ground pin as close as possible to the device. Under no circumstances should the voltage at  $V_{BB}$  exceed 45 V.

The PHASE input to each bridge determines the direction motor winding current flows. An internally generated deadtime, of approximately  $3 \mu\text{s}$ , prevents crossover currents that can occur when switching the PHASE input.

All four drivers in the bridge output can be turned OFF, with  $V_{EN} \geq 2.4$ , resulting in a fast current decay through the internal ground clamp and flyback diodes. The fast current decay is desirable in half-step and high-speed applications. The ENABLE input must be tied low if it is not used.

Varying the reference voltage ( $V_{REF}$ ) provides continuous control of the peak load current.

Thermal protection circuitry turns OFF all drivers when the junction temperature reaches approximately  $+170^\circ\text{C}$ . It is intended only to protect the device from failures due to excessive junction temperature and should not imply that output short circuits are permitted. The output drivers are re-enabled when the junction temperature cools to approximately  $+145^\circ\text{C}$ .

## LOAD CURRENT PATHS

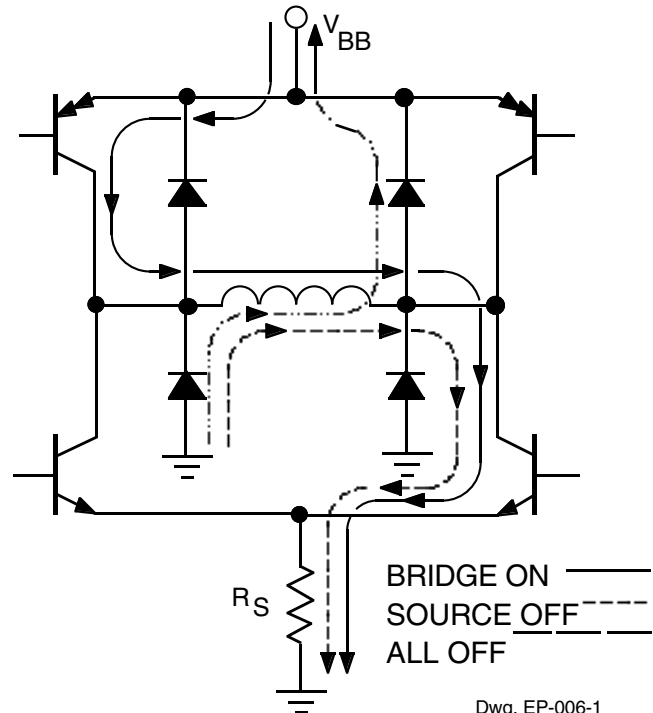

Dwg. EP-006-1

*The products described here are manufactured in Japan by Sanken Electric Co., Ltd. for sale by Allegro MicroSystems, Inc.*

*Sanken Electric Co., Ltd. and Allegro MicroSystems, Inc. reserve the right to make, from time to time, such departures from the detail specifications as may be required to permit improvements in the performance, reliability, or manufacturability of their products. Therefore, the user is cautioned to verify that the information in this publication is current before placing any order.*

*These products are not authorized for use as critical components in life-support appliances, devices, or systems without express written approval.*

*The information included herein is believed to be accurate and reliable. However, Sanken Electric Co., Ltd. and Allegro MicroSystems, Inc. assume no responsibility for its use; nor for any infringements of patents or other rights of third parties which may result from its use.*

# 2918 DUAL FULL-BRIDGE PWM MOTOR DRIVER

## A2918SWH for horizontal mounting

Dimensions in Inches  
(for reference only)

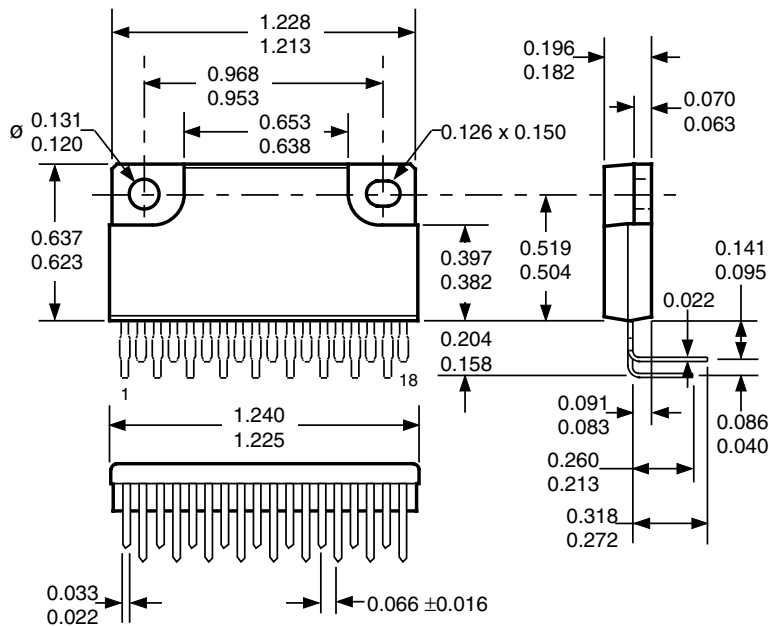

Dimensions in Millimeters  
(controlling dimensions)

Dwg. MP-006 in

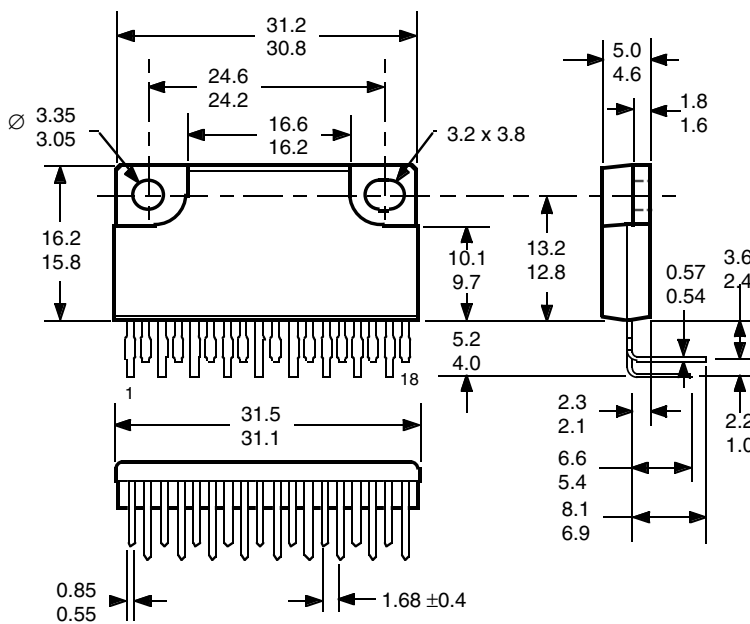

- NOTES: 1. Exact body and lead configuration at vendor's option within limits shown. Dwg. MP-006 mm  
2. Lead spacing tolerance is non-cumulative.



115 Northeast Cutoff, Box 15036  
Worcester, Massachusetts 01615-0036 (508) 853-5000

# 2918 DUAL FULL-BRIDGE PWM MOTOR DRIVER

## A2918SWV for vertical mounting

Dimensions in Inches  
(for reference only)

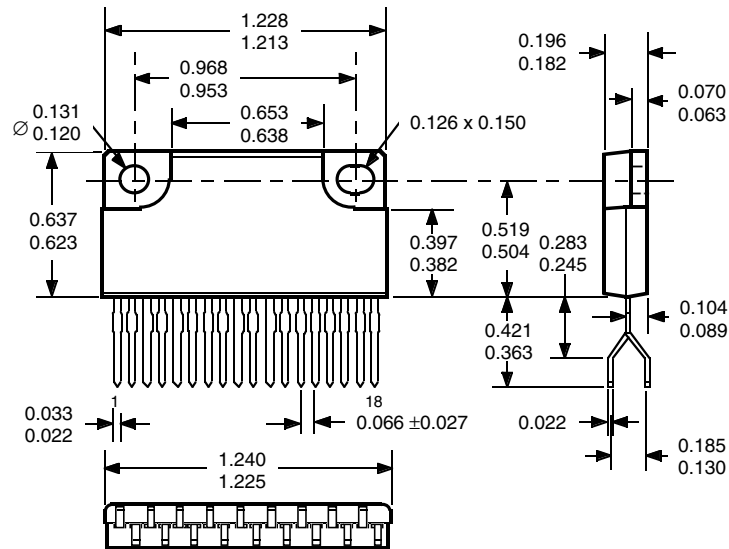

Dwg. MP-004 in

Dimensions in Millimeters  
(controlling dimensions)

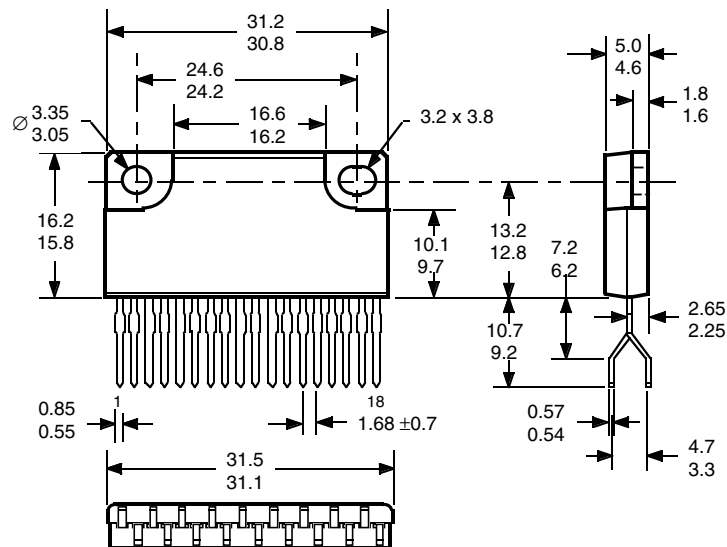

Dwg. MP-004 mm

- NOTES: 1. Exact body and lead configuration at vendor's option within limits shown.  
2. Lead spacing tolerance is non-cumulative.

**2918**  
**DUAL FULL-BRIDGE**  
**PWM MOTOR DRIVER**

**MOTOR DRIVERS**

Function	Output Ratings*		Part Number†
<b>INTEGRATED CIRCUITS FOR BRUSHLESS DC MOTORS</b>			
3-Phase Power MOSFET Controller	—	28 V	3933
3-Phase Power MOSFET Controller	—	50 V	3932
3-Phase Power MOSFET Controller	—	50 V	7600
2-Phase Hall-Effect Sensor/Driver	400 mA	26 V	3626
Bidirectional 3-Phase Back-EMF Controller/Driver	±600 mA	14 V	8906
2-Phase Hall-Effect Sensor/Driver	900 mA	14 V	3625
3-Phase Back-EMF Controller/Driver	±900 mA	14 V	8902–A
3-Phase Controller/Drivers	±2.0 A	45 V	2936 & 2936-120
<b>INTEGRATED BRIDGE DRIVERS FOR DC AND BIPOLAR STEPPER MOTORS</b>			
Dual Full Bridge with Protection & Diagnostics	±500 mA	30 V	3976
PWM Current-Controlled Dual Full Bridge	±650 mA	30 V	3966
PWM Current-Controlled Dual Full Bridge	±650 mA	30 V	3968
PWM Current-Controlled Dual Full Bridge	±750 mA	45 V	2916
PWM Current-Controlled Dual Full Bridge	±750 mA	45 V	2919
PWM Current-Controlled Dual Full Bridge	±750 mA	45 V	6219
PWM Current-Controlled Dual Full Bridge	±800 mA	33 V	3964
PWM Current-Controlled Full Bridge	±1.3 A	50 V	3953
PWM Current-Controlled Dual Full Bridge	±1.5 A	45 V	2917
PWM Current-Controlled Microstepping Full Bridge	±1.5 A	50 V	3955
PWM Current-Controlled Microstepping Full Bridge	±1.5 A	50 V	3957
PWM Current-Controlled Dual DMOS Full Bridge	±1.5 A	50 V	3972
Dual Full-Bridge Driver	±2.0 A	50 V	2998
PWM Current-Controlled Full Bridge	±2.0 A	50 V	3952
DMOS Full Bridge PWM Driver	±2.0 A	50 V	3958
Dual DMOS Full Bridge	±2.5 A	50 V	3971
<b>UNIPOLAR STEPPER MOTOR &amp; OTHER DRIVERS</b>			
Voice-Coil Motor Driver	±500 mA	6 V	8932–A
Voice-Coil Motor Driver	±800 mA	16 V	8958
Unipolar Stepper-Motor Quad Drivers	1 A	46 V	7024 & 7029
Unipolar Microstepper-Motor Quad Driver	1.2 A	46 V	7042
Unipolar Stepper-Motor Translator/Driver	1.25 A	50 V	5804
Unipolar Stepper-Motor Quad Driver	1.8 A	50 V	2540
Unipolar Stepper-Motor Quad Driver	1.8 A	50 V	2544
Unipolar Stepper-Motor Quad Driver	3 A	46 V	7026
Unipolar Microstepper-Motor Quad Driver	3 A	46 V	7044

\* Current is maximum specified test condition, voltage is maximum rating. See specification for sustaining voltage limits or over-current protection voltage limits. Negative current is defined as coming out of (sourcing) the output.

† Complete part number includes additional characters to indicate operating temperature range and package style.

Also, see 3175, 3177, 3235, and 3275 Hall-effect sensors for use with brushless dc motors.



115 Northeast Cutoff, Box 15036  
Worcester, Massachusetts 01615-0036 (508) 853-5000