

MULTIPLEXED TWO-WIRE HALL-EFFECT SENSOR ICs

The A3054KU and A3054SU Hall-effect sensors are digital magnetic sensing ICs capable of communicating over a two-wire power/signal bus. Using a sequential addressing scheme, the device responds to a signal on the bus and returns the diagnostic status of the IC, as well as the status of each monitored external magnetic field. As many as 30 sensors can function on the same two-wire bus. This IC is ideal for multiple sensor applications where minimizing the wiring harness size is desirable or essential.

Each device consists of high-resolution bipolar Hall-effect switching circuitry, the output of which drives high-density CMOS logic stages. The logic stages decode the address pulse and enable a response at the appropriate address. The combination of magnetic-field or switch-status sensing, low-noise amplification of the Hall-transducer output, and high-density decoding and control logic is made possible by the development of a new sensor DABiC™ (digital analog bipolar CMOS) fabrication technology. The A3054SU is an improved replacement for the original UGN3055U.

These unique magnetic sensing ICs are available in two temperature ranges; the A3054SU operates within specifications between -20°C and +85°C, while the A3054KU is rated for operation between -40°C and +125°C. Alternative magnetic and temperature specifications are available on special order. Both versions are supplied in 0.060" (1.54 mm) thick, three-pin plastic SIPs. Each device is clearly marked with a two-digit device address (XX).

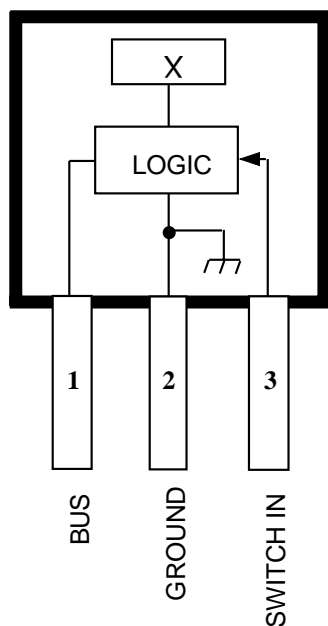

Dwg. PH-005

Pinning is shown viewed from branded side.

ABSOLUTE MAXIMUM RATINGS at T_A = +25°C

Supply Voltage, V _{BUS}	18 V
Magnetic Flux Density, B	Unlimited
Operating Temperature Range, T _A	
A3054KU	-40°C to +125°C
A3054SU	-20°C to +85°C
Storage Temperature Range,	
T _S	-55°C to +150°C
Package Power Dissipation,	
P _D	635 mW

FEATURES

- Complete Multiplexed Hall-Effect ICs with Simple Sequential Addressing Protocol
- Allows Power and Communication Over a Two-Wire Bus (Supply/Signal and Ground)
- Up to 30 Hall-Effect Sensors Can Share a Bus
- Sensor Diagnostic Capabilities
- Magnetic-Field or Switch-Status Sensing
- Low Power of DABiC Technology Favors Battery-Powered and Mobile Applications
- Ideal for Automotive, Consumer, and Industrial Applications

Always order by complete part number:

Part Number	Operating Temperature Range
A3054KU-XX	-40°C to +125°C
A3054SU-XX	-20°C to +85°C

where XX = address (01, 02, ... 29, 30).

3054
MULTIPLEXED
TWO-WIRE
HALL-EFFECT SENSOR ICs

ELECTRICAL CHARACTERISTICS over operating temperature range.

Characteristic	Symbol	Test Conditions	Limits			Units
			Min	Typ	Max	
Power Supply Voltage	V_{BUS}		—	—	15	V
Signal Current	I_S	DUT Addressed, B > 300 G	12	15	20	mA
Quiescent Current	I_{QL}	$V_{BUS} = 6\text{ V}$	—	1.5	2.5	mA
	I_{QH}	$V_{BUS} = 9\text{ V}$	—	1.4	2.5	mA
	ΔI_Q	$I_{QL} - I_{QH}$	—	100	300	μA
Address Range	Addr	Factory Specified	1	—	30	—
Clock Thresholds	V_{CLH}	LOW to HIGH	—	—	8.5	V
	V_{CHL}	HIGH to LOW	6.5	—	—	V
	V_{CHYS}	Hysteresis	—	0.8	—	V
Max. Clock Frequency*	f_{CLK}	50% Duty Cycle	2.5	—	—	kHz
Address LOW Voltage	V_L		V_{RST}	6.0	V_{CHL}	V
Address HIGH Voltage	V_H		V_{CLH}	9.0	V_{BUS}	V
Reset Voltage	V_{RST}		2.5	3.5	5.5	V
Propagation Delay*	t_{pLH}	LOW to HIGH	10	20	30	μs
	t_{pHL}	HIGH to LOW	—	5.0	10	μs
Pin 3-2 Resistance	R_{SWH}	DUT Addressed, B < 5 G	—	50	—	k Ω
	R_{SWL}	DUT Addressed, B > 300 G	—	200	—	Ω
Pin 3-2 Output Voltage	V_{SWH}	DUT Addressed, B < 5 G	—	3.9	—	V
	V_{SWL}	DUT Addressed, B > 300 G	—	30	—	mV

MAGNETIC CHARACTERISTICS over operating temperature range.

Characteristic	Symbol	Test Conditions	Limits			Units
			Min.	Typ.	Max.	
Magnetic Threshold†	B_{OP}	Turn-On	50	150	300	G
	B_{RP}	Turn-Off	5.0	100	295	G
Hysteresis	B_{HYS}	$B_{OP} - B_{RP}$	5.0	50	—	G

Typical Data is at $T_A = +25^\circ\text{C}$ and is for design information only.

*This parameter, although warranted, is not production tested.

†Alternative magnetic switch point specifications are available on special order. Please contact the factory.



115 Northeast Cutoff, Box 15036
Worcester, Massachusetts 01615-0036 (508) 853-5000
Copyright © 1995 Allegro MicroSystems, Inc.

3054 MULTIPLEXED TWO-WIRE HALL-EFFECT SENSOR ICs

SENSOR LOCATION

(±0.005" [0.13 mm] die placement)

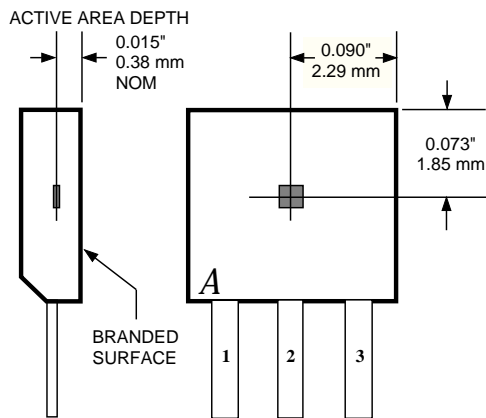

Dwg. MH-002-10A

FUNCTIONAL BLOCK DIAGRAM

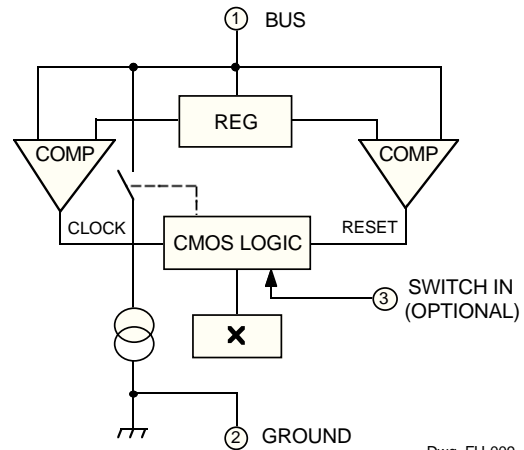

Dwg. FH-009

DEFINITION OF TERMS

Sensor Address

Each bus sensor has a factory-specified predefined address. At present, allowable sensor addresses are integers from 01 to 30.

LOW-to-HIGH Clock Threshold (V_{CLH})

Minimum voltage required during the positive-going transition to increment the bus address and trigger a diagnostic response from the bus sensors. This is also the maximum threshold of the on-chip comparator that monitors the supply voltage, V_{BUS} .

HIGH-to-LOW Threshold (V_{HL})

Maximum voltage required during the negative-going transition to trigger a *signal* current response from the bus sensors. This is also the maximum threshold of the on-chip comparator that monitors the supply voltage, V_{BUS} .

Bus HIGH Voltage (V_H)

Bus HIGH voltage during addressing. Voltage should be greater than V_{CLH} .

Address LOW Voltage (V_L)

Bus LOW voltage during addressing. Voltage should be greater than V_{RST} and less than V_{CHL} .

Bus Reset Voltage (V_{RST})

Voltage level while resetting sensors.

Sensor Quiescent Current Drain (I_Q)

The current drain of bus sensors when active but not addressed. I_{QH} is the quiescent current drain when the sensor is not addressed and is at V_H . I_{QL} is the quiescent current drain when the sensor is not addressed and is at V_L . Note that I_{QL} is greater than I_{QH} .

Diagnostic Phase

Period on the bus when the address voltage is at V_H . During this period, a correctly addressed sensor responds by increasing its current drain on the bus. This response from the sensor is called the **diagnostic response** and the bus current *increase* is called the **diagnostic current**.

Signal Phase

Period on the bus when the address voltage is at V_L . During this period, a correctly addressed sensor that detects a magnetic field greater than the magnetic operate point, B_{OP} , responds by maintaining a current drain of I_S on the bus. This response from the sensor is called the **signal response** and the bus current is called the **signal current**.

Sensor Address Response Current (I_S)

Sensor current during the *diagnostic* and the *signal* responses of the bus sensor. This is accomplished by enabling an internal constant-current source.

3054 MULTIPLEXED TWO-WIRE HALL-EFFECT SENSOR ICs

ADDRESSING PROTOCOL

Magnetic Operate Point (B_{OP})

Minimum magnetic field required to switch ON the Hall amplifier and switching circuitry of the addressed sensor. This circuitry is only active when the sensor is addressed.

Magnetic Release Point (B_{RP})

Magnetic field required to switch OFF the Hall amplifier and switching circuitry after the output has been switched ON. When a device is deactivated by changing the bus address, all magnetic memory is lost.

Magnetic Hysteresis (B_{HYS})

Difference between the B_{OP} and B_{RP} magnetic field thresholds.

A device may be addressed by changing the supply voltage as shown in Figure 1. A preferred addressing protocol is as follows: the bus supply voltage is brought low (<2.5 V) so that all devices on the bus are reset. The voltage is then raised to the address LOW voltage (V_L) and the bus quiescent current is measured. The bus is then toggled between V_L and V_H (address HIGH voltage), with each positive transition representing an increment in the bus address. After each voltage transition, the bus current may be monitored to check for diagnostic and signal responses from sensor ICs.

Sensor Addressing

When a sensor detects a bus address equal to its factory-programmed address, it responds with an increase in its supply current drain (I_S) during the next HIGH portion

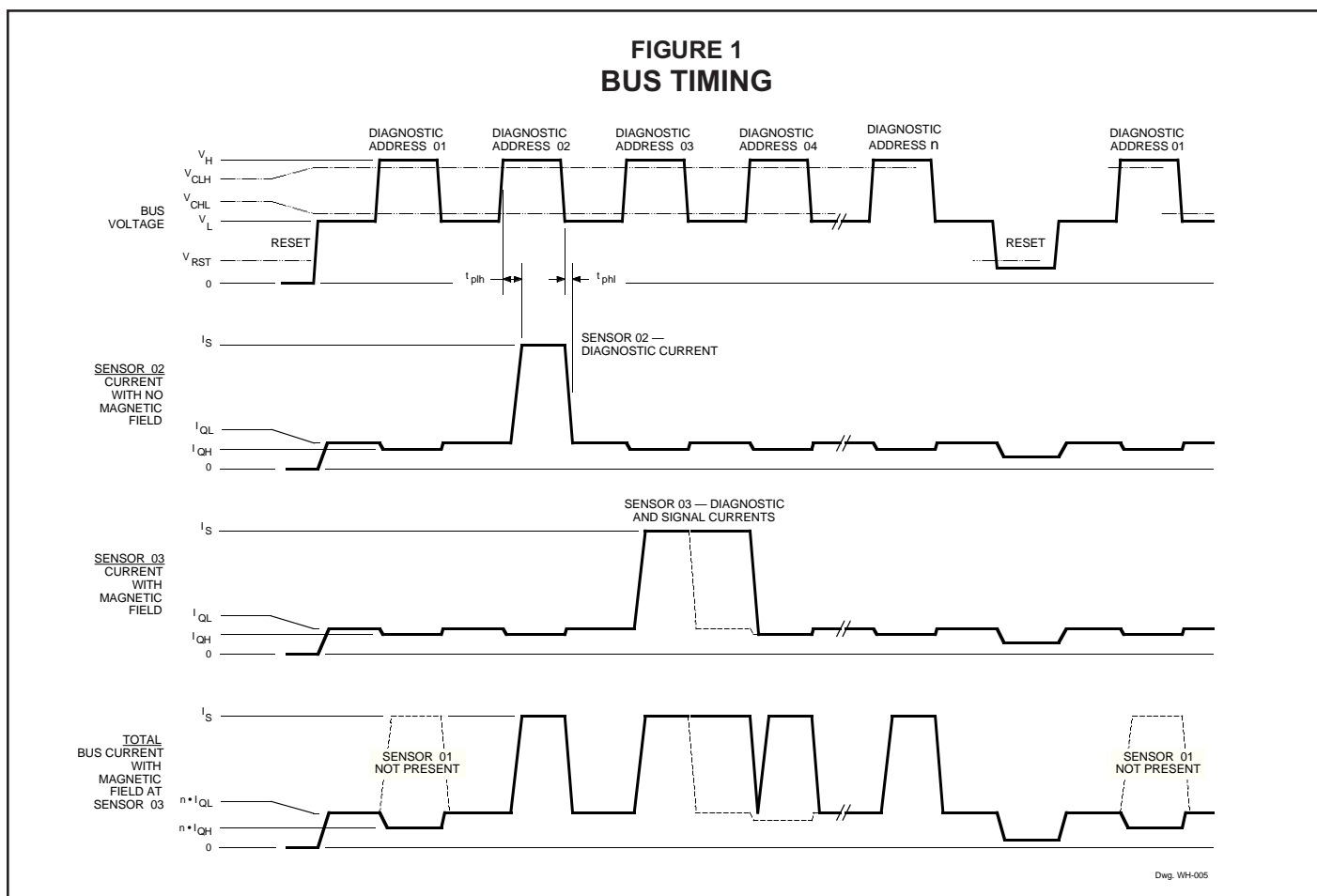

3054 MULTIPLEXED TWO-WIRE HALL-EFFECT SENSOR ICs

of the address cycle. This response may be used as an indication that the sensor is "alive and well" on the bus and is called the *diagnostic* response. If the sensor detects an ambient magnetic field, it continues with I_S during the low portion of the address cycle. This response from the sensor is called the *signal* response. When the next positive (address) transition is detected, the sensor becomes disabled, and its contribution to the bus signal current returns to I_Q .

Bus Current

Figure 1 shows the addressing protocol. The top trace represents the bus voltage transitions as controlled by the bus driver (see Applications Notes for an optimal bus driver schematic). The second trace represents the bus current contribution of Sensor 02. The *diagnostic* response from the sensor indicates that it detected its address on the bus. However, no *signal* current is shown, which indicates that sufficient magnetic field is not detected at the chip surface and that pin 3 is open circuited. The third trace represents the current drain of Sensor 03 when a magnetic field is detected. Note both the *diagnostic* and *signal* currents from the sensor. The last trace represents the overall bus current drain. When no sensors are addressed, the net bus current is the sum of quiescent currents of all sensors on the bus (for 'n' sensors, the bus current drain is $n \cdot I_Q$).

Bus Issues

After a reset, while at the address LOW voltage (V_L), and before the first address pulse, bus current calibration may be performed. This feature allows for fail-safe detection of signal current and eliminates detection problems caused by low signal current (I_S), the operation of sensors at various ambient temperatures, lot-to-lot variation of quiescent current, and the addition or replacement of sensors to the bus while in the field. At present, a maximum of 30 active sensors can coexist on the same bus, each with a different address. Address

TYPICAL DEVICE QUIESCENT CURRENT

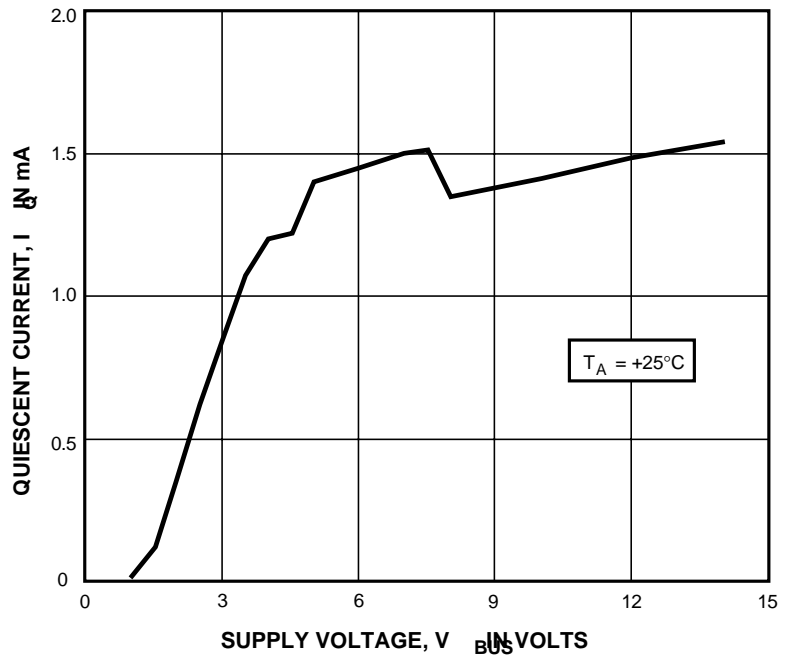

Dwg. GH-045

FIGURE 2
SENSOR CONNECTIONS

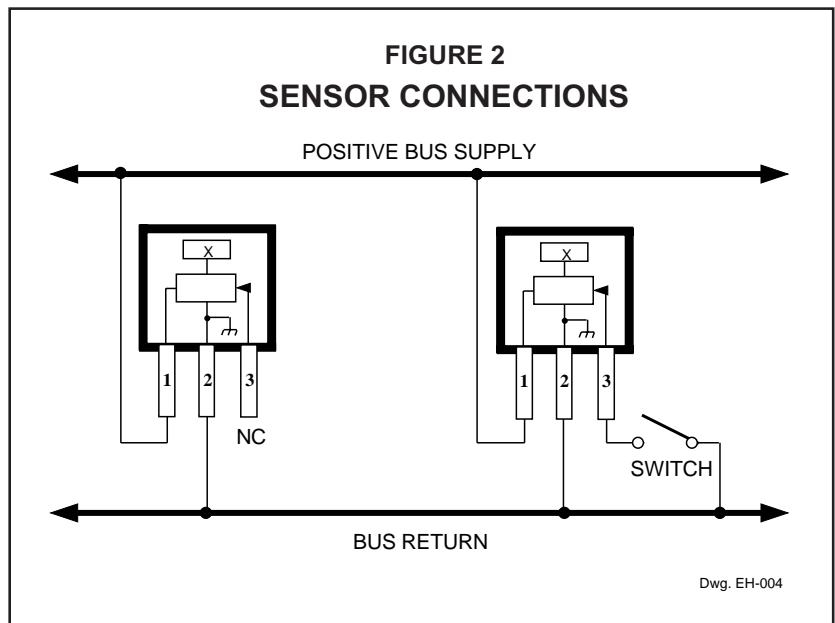

Dwg. EH-004

3054 MULTIPLEXED TWO-WIRE HALL-EFFECT SENSOR ICs

FIGURE 3
BUS INTERCONNECTION

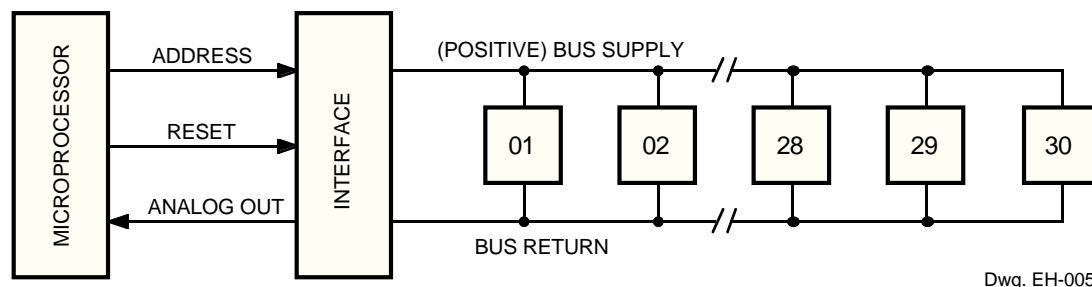

31 is designed to be inactive to allow for further address expansion of the bus (to 62 maximum addresses). In order to repeat the address cycle, the bus must be reset, as shown in Figure 1, by bringing the supply voltage to below V_{RST} . Sensors have been designed not to 'wrap-around'.

Magnetic Sensing

The sensor IC has been designed to respond to an external magnetic field whose magnetic strength is greater than B_{OP} . It accomplishes this by amplifying the output of an on-chip Hall transducer and applying it to a threshold detector. In order that bus current is kept to a minimum, the transducer and amplification circuitry is kept powered down until the sensor is addressed. Hence, the magnetic status is evaluated only when the sensor is addressed.

External Switch Sensing

Pin 3 of the IC may be used to detect the status of an external switch when magnetic field sensing is not desired (and in the absence of a magnetic field). The allowable states for the switch are 'open' or 'closed' (shorted to sensor ground).

APPLICATIONS NOTES

Magnetic Actuation

The left side of Figure 2 shows the wiring of an A3054KU or A3054SU when used as a magnetic threshold detector. Pin 1 of the sensor is wired to the positive terminal of the bus, pin 2 is connected to the bus negative terminal, and *pin 3 has no connection*.

Mechanical Actuation

The right side of Figure 2 shows the wiring of an A3054KU or A3054SU when used to detect the status of a mechanical switch. In this case, pin 3 is connected to the switch. The other side of the switch is connected to the bus return (negative bus supply or ground). When the mechanical switch is closed, and the correct bus address is detected by the IC, the sensor responds with a signal current. If the switch is open, only the diagnostic current is returned.

Bus Configuration

A maximum of 30 individually addressable sensors may be connected across the same two-wire bus as shown in Figure 3. It is recommended that the sensors use a dedicated digital ground wire to minimize the effects of changing ground potential (as in the case of chassis ground in the automotive industry).

The bus was not designed to require two-wire twisted pair wiring to the sensors. However, in areas of extreme electromagnetic interference, it may be advisable to install a small bypass capacitor (0.01 μF for example) between the supply and ground terminals of each sensor instead of using the more expensive wiring.

3054 MULTIPLEXED TWO-WIRE HALL-EFFECT SENSOR ICs

Bus Driver

It is recommended that the bus be controlled by microprocessor-based hardware for the following reasons:

- Sensor address information may be stored in ROM in the form of a look-up table.
- Bus faults can be pinpointed by the microprocessor by comparing the diagnostic response to the expected response in the ROM look-up table.
- The microprocessor, along with an A/D converter, can also be used to self calibrate the quiescent currents in the bus and hence be able to easily detect a signal response.

- The microprocessor can also be used to filter out random line noise by digitally filtering the bus responses.
- The microprocessor can easily keep track of the signal responses and initiate the appropriate action (e.g., light a lamp or sound an alarm, and also pinpoint the location of the signal).

Optimally, the microprocessor is used to control bus-driving circuitry that will accept TTL-level inputs to drive the bus and will return an analog voltage representation of the bus current.

Interface Schematic

The bus driver is easily designed using a few operational amplifiers, resistors, and transistors. Figure 4 shows a schematic of a recommended bus driver circuit that is capable of providing 6 V to 9 V transitions, resetting the bus, and providing an analog measurement of the bus current for the A/D input of the microprocessor.

**FIGURE 4
BUS INTERFACE SCHEMATIC**

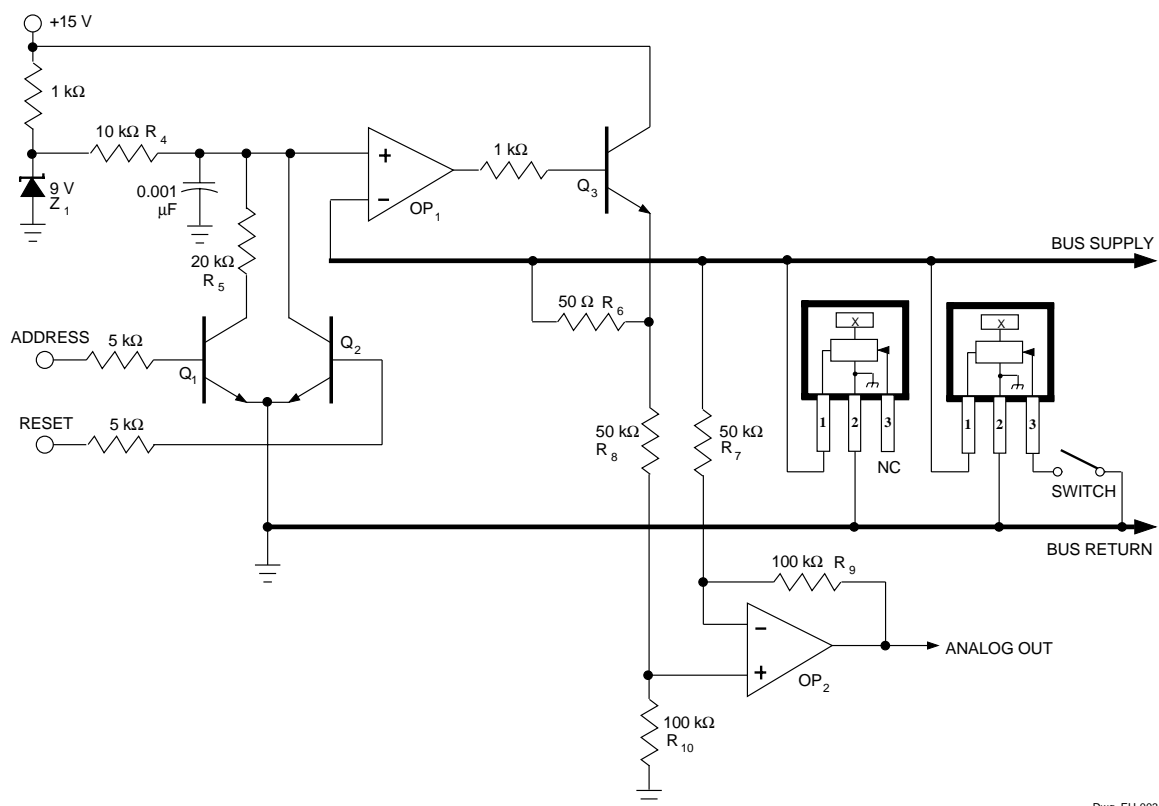

Dwg. EH-003A

3054 MULTIPLEXED TWO-WIRE HALL-EFFECT SENSOR ICs

In Figure 4, the ADDRESS input provides a TTL-compatible input to control the bus supply. A HIGH (5 V) input switches Q₁ ON and sets the bus voltage to 6 V through the resistor divider R₄, R₅, and Zener Z₁. A LOW input switches Q₁ OFF and sets the bus voltage to 9 V (Z₁). This voltage is fed into the positive input of the operational amplifier OP₁ and is buffered and made available at BUS SUPPLY (or sensor supply). Bus reset control is also available in the form of a TTL-compatible input. When the RESET input is HIGH, Q₂ is switched ON and the positive input of the operational amplifier is set to the saturation voltage of the transistor (approximately 0 V). This resets the bus.

A linear reading of the bus current is made possible by amplifying the voltage generated across R₆ (which is I_{BUS} • R₆). The amplifier, OP₂, is a standard differential amplifier of gain R₉/R₇ (provided that R₇ = R₈, R₉ = R₁₀). The gain of the total transimpedance amplifier is given by:

$$V_{OUT} = I_{BUS} \cdot R_6 \cdot R_9/R_7$$

This voltage is available at the ANALOG OUT terminal.

Bus Control Software

The processing of the bus current (available at ANALOG OUT) is best done by feeding it into the A/D input of a microprocessor. If the flexibility provided by a microprocessor is not desired, this signal could be fed into threshold detection circuitry; e.g., comparator, and the output used to drive a display.

Related References

1. G. AVERY, "Two-Terminal Hall Sensor," *ASSIGNEE: Sprague Electric Company, North Adams, MA, United States. Patent number 4,374,333; Feb. 1983.*
2. T. WROBLEWSKI and F. MEISTERFIELD, "Switch Status Monitoring System, Single-Wire Bus, Smart Sensor Arrangement There Of," *ASSIGNEE: Chrysler Motor Corporation, Highland Park, MI, United States. Patent number 4,677,308; June 1987.*



3054 MULTIPLEXED TWO-WIRE HALL-EFFECT SENSOR ICs

Dimensions in Inches
(controlling dimensions)

Dimensions in Millimeters
(for reference only)

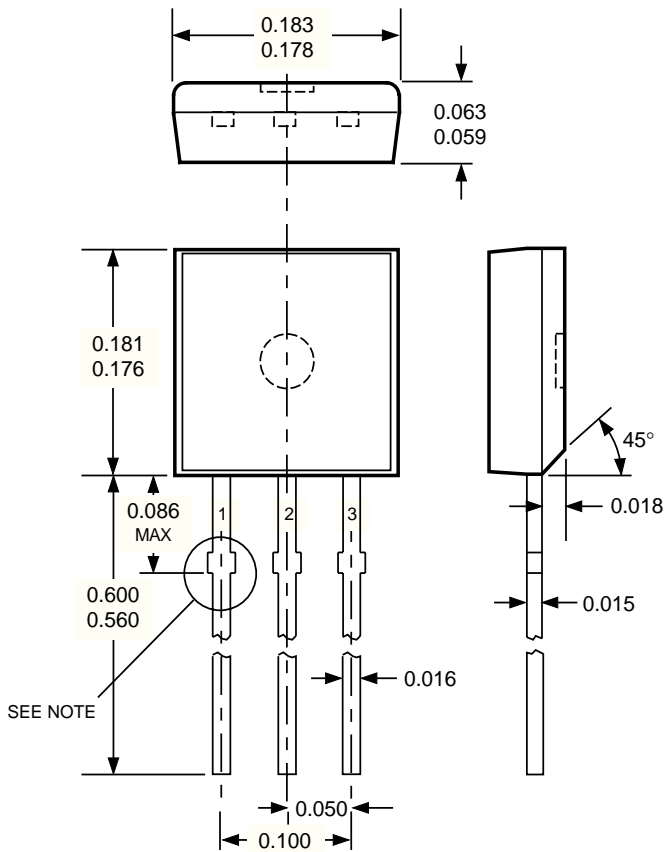

Dwg. MH-003D in

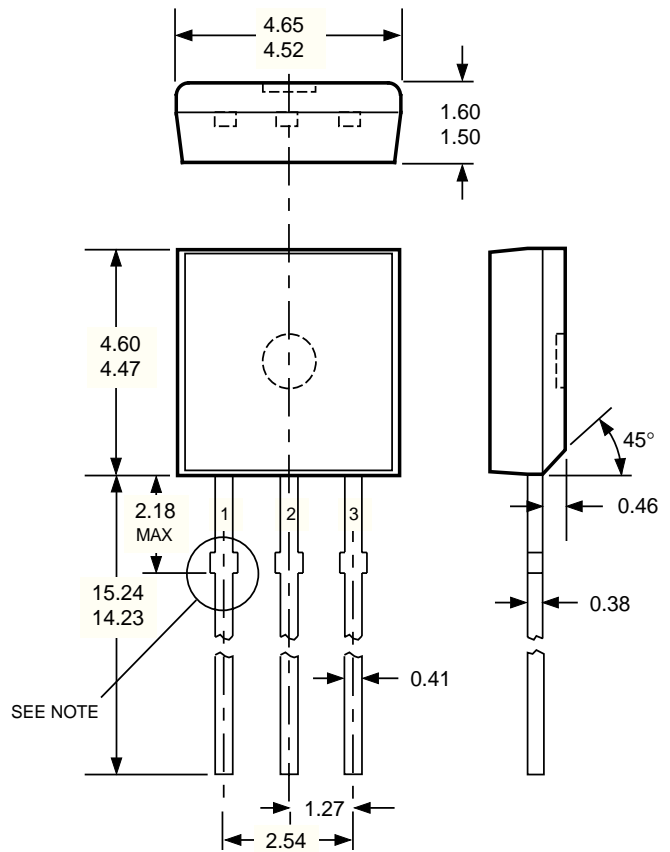

Dwg. MH-003D mm

- NOTES:
1. Tolerances on package height and width represent allowable mold offsets. Dimensions given are measured at the widest point (parting line).
 2. Exact body and lead configuration at vendor's option within limits shown.
 3. Height does not include mold gate flash.
 4. Recommended minimum PWB hole diameter to clear transition area is 0.035" (0.89 mm).
 5. Where no tolerance is specified, dimension is nominal.
 6. Minimum lead length was 0.500" (12.70 mm). If existing product to the original specifications is not acceptable, contact sales office before ordering.

3054
MULTIPLEXED
TWO-WIRE
HALL-EFFECT SENSOR ICs

This page intentionally left blank



115 Northeast Cutoff, Box 15036
Worcester, Massachusetts 01615-0036 (508) 853-5000

3054
MULTIPLEXED
TWO-WIRE
HALL-EFFECT SENSOR ICs

Allegro MicroSystems, Inc. reserves the right to make, from time to time, such departures from the detail specifications as may be required to permit improvements in the design of its products. The information included herein is believed to be accurate and reliable. However, Allegro MicroSystems, Inc. assumes no responsibility for its use; nor for any infringements of patents or other rights of third parties which may result from its use.

3054
MULTIPLEXED
TWO-WIRE
HALL-EFFECT SENSOR ICs

HALL-EFFECT SENSORS SELECTION GUIDE

Partial Part Number	Avail. Oper. Temp.	Operate Limits Over Temp.			Function†	Notes
		B _{OP} max	B _{RP} min	B _{hys} min		
3046	E/L	+200	-200	15	Gear-Tooth Sensor	
3054	K/S	+300	+5	5.0	Unipolar Multiplex	1
3056	E/L	+225	-225	15	Gear-Tooth Sensor	
3058	E/L	+300	-300	150	Gear-Tooth Sensor	
3059	K/S	+100	-100	20	AC Gear-Tooth Sensor	
3060	K/S	+35	-35	10	AC Gear-Tooth Sensor	
3121	E/L	+500	+80	60	Unipolar Switch	
3122	E/L	+430	+120	70	Unipolar Switch	
3123	E/L	+470	+160	70	Unipolar Switch	
3132	K/L/S	+95	-95	30	Bipolar Switch	
3133	K/L/S	+75	-75	30	Bipolar Switch	
3134	E/L	+50	-40	10	Bipolar Switch	
3141	E/L	+175	+10	20	Unipolar Switch	
3142	E/L	+245	+60	30	Unipolar Switch	
3143	E/L	+355	+150	30	Unipolar Switch	
3144	E/L	+450	+25	20	Unipolar Switch	
3161	E	+160	+30	5.0	2-Wire Unipolar Switch	
3175	S	+180	-180	80	Bipolar Latch	
3177	S	+150	-150	50	Bipolar Latch	
3185	E/L	+300	-300	280	Bipolar Latch	
3187	E/L	+175	-175	100	Bipolar Latch	
3188	E/L	+200	-200	160	Bipolar Latch	
3189	E/L	+250	-250	100	Bipolar Latch	
3195	E/L	+200	-200	110	Bipolar Latch	2, 3
3197	L	+200	-200	110	Bipolar Latch	3
3235	S	+200	+15	15	Unipolar Switch	4
		-200	-15	15	Unipolar Switch	
3275	S	+250	-250	100	Bipolar Latch	5
3421	E/L	+300	-300	240	Direction Detection	
3422	E/L	+85	-85	10	Direction Detection	
3503	S	Typ. 1.3 mV/G		–	Linear Sensor	
3515	E/L	Typ. 5.0 mV/G		–	Chopper-Stabilized Linear Sensor	
3516	E/L	Typ. 2.5 mV/G		–	Chopper-Stabilized Linear Sensor	
3517	L/S	Typ. 5.0 mV/G		–	Chopper-Stabilized Linear Sensor	
3518	L/S	Typ. 2.5 mV/G		–	Chopper-Stabilized Linear Sensor	
3625	S	+150	-150	200*	900 mA Bipolar Latch	3, 5, 6
3626	S	+150	-150	200*	400 mA Bipolar Latch	3, 5, 6
5140	E	+240	+25	20	300 mA Unipolar Switch	3, 6

Operating Temperature Ranges:

C = 0°C to +70°C, S = -20°C to +85°C, E = -40°C to +85°C, K = -40°C to +125°C, L = -40°C to +150°C

Notes 1. Multiplexed two-wire sensor; after proper address, power/signal bus current indicates magnetic field condition.

2. Active pull down.

3. Protected.

4. Output 1 switches on south pole, output 2 switches on north pole for 2-phase, bifilar-wound, unipolar-driven brushless dc motor control.

5. Complementary outputs for 2-phase bifilar-wound, unipolar-driven brushless dc motor control.

6. Power driver output.

* Typical.

† Latches will not switch on removal of magnetic field; bipolar switches may switch on removal of field but require field reversal for reliable operation over operating temperature range.



115 Northeast Cutoff, Box 15036
Worcester, Massachusetts 01615-0036 (508) 853-5000