

# 3185 THRU 3189

## HALL-EFFECT LATCHES FOR HIGH-TEMPERATURE OPERATION

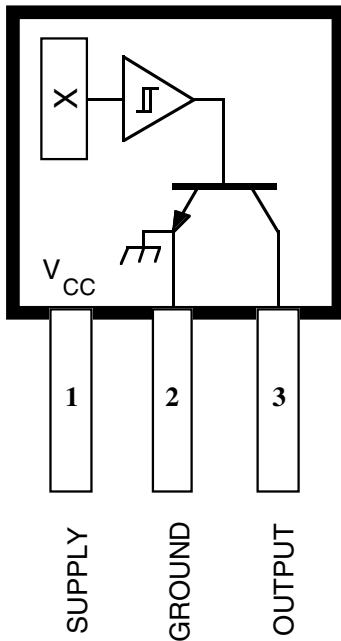

Dwg. PH-003A

Pinning is shown viewed from branded side.

### ABSOLUTE MAXIMUM RATINGS at $T_A = +25^\circ\text{C}$

Supply Voltage, $V_{CC}$ .....	30 V
Reverse Battery Voltage, $V_{RCC}$ .....	-30 V
Magnetic Flux Density, B .....	Unlimited
Output OFF Voltage, $V_{OUT}$ .....	30 V
Reverse Output Voltage, $V_{OUT}$ .....	-0.5 V
Continuous Output Current, $I_{OUT}$ .....	25 mA
Operating Temperature Range, $T_A$	
Suffix 'E-' .....	-40°C to +85°C
Suffix 'L-' .....	-40°C to +150°C
Storage Temperature Range,	
$T_S$ .....	-65°C to +170°C

These Hall-effect latches are extremely temperature-stable and stress-resistant sensors especially suited for operation over extended temperature ranges to +150°C. Superior high-temperature performance is made possible through a novel Schmitt trigger circuit that maintains operate and release point symmetry by compensating for temperature changes in the Hall element. Additionally, internal compensation provides magnetic switch points that become more sensitive with temperature, hence offsetting the usual degradation of the magnetic field with temperature. The symmetry capability makes these devices ideal for use in pulse-counting applications where duty cycle is an important parameter. The four basic devices (3185, 3187, 3188, and 3189) are identical except for magnetic switch points.

Each device includes on a single silicon chip a voltage regulator, quadratic Hall-voltage generator, temperature compensation circuit, signal amplifier, Schmitt trigger, and a buffered open-collector output to sink up to 25 mA. The on-board regulator permits operation with supply voltages of 3.8 to 24 volts.

The first character of the part number suffix determines the device operating temperature range. Suffix 'E-' is for -40°C to +85°C, and suffix 'L-' is for -40°C to +150°C. Three package styles provide a magnetically optimized package for most applications. Suffix '-LT' is a miniature SOT-89/TO-243AA transistor package for surface-mount applications; suffix '-U' is a three-lead plastic mini-SIP, while suffix '-UA' is a three-lead ultra-mini-SIP.

### FEATURES

- Symmetrical Switch Points
- Superior Temperature Stability
- Operation From Unregulated Supply
- Open-Collector 25 mA Output
- Reverse Battery Protection
- Activate With Small, Commercially Available Permanent Magnets
- Solid-State Reliability
- Small Size
- Resistant to Physical Stress

Always order by complete part number: the prefix 'A' + the basic four-digit part number + a suffix to indicate operating temperature range + a suffix to indicate package style, e.g., **A3185ELT**.

# 3185 THRU 3189 HALL-EFFECT LATCHES FOR HIGH-TEMPERATURE OPERATION

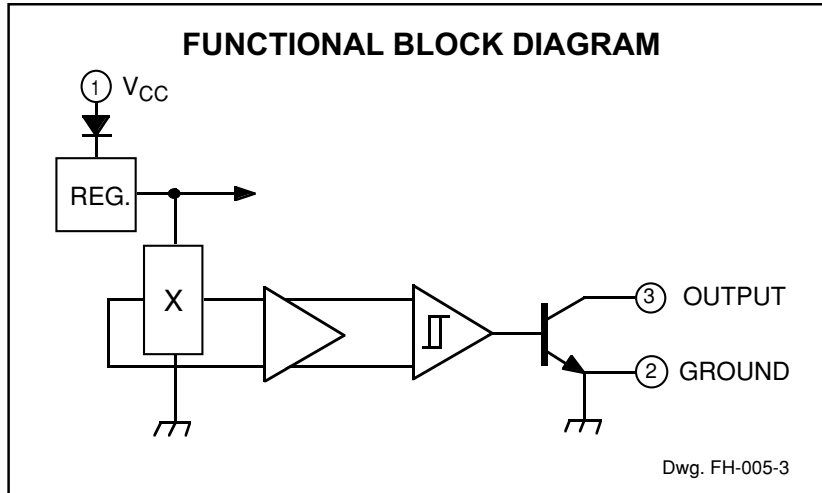

## ELECTRICAL CHARACTERISTICS over operating temperature range, at $V_{CC} = 12\text{ V}$ .

Characteristic	Symbol	Test Conditions	Limits			
			Min.	Typ.	Max.	Units
Supply Voltage	$V_{CC}$	Operating	3.8	—	24	V
Output Saturation Voltage	$V_{OUT(SAT)}$	$I_{OUT} = 20\text{ mA}$ , $B > B_{OP}$	—	175	400	mV
Output Leakage Current	$I_{OFF}$	$V_{OUT} = 24\text{ V}$ , $B < B_{RP}$	—	0.05	5.0	$\mu\text{A}$
Supply Current	$I_{CC}$	$B < B_{RP}$ (Output OFF)	—	4.75	8.0	mA
		$B > B_{OP}$ (Output ON)	—	5.7	—	mA
Output Rise Time	$t_r$	$R_L = 820\ \Omega$ , $C_L = 20\text{ pF}$	—	100	—	ns
Output Fall Time	$t_f$	$R_L = 820\ \Omega$ , $C_L = 20\text{ pF}$	—	100	—	ns

## MAGNETIC CHARACTERISTICS in gauss over operating supply voltage range.

Characteristic	Part Numbers*							
	A3185		A3187		A3188		A3189	
	Min.	Max.	Min.	Max.	Min.	Max.	Min.	Max.
$B_{OP}$ at $T_A = 25^\circ\text{C}$	170	270	50	150	100	180	50	230
over operating temp. range	140	300	50	175	80	200	50	250
$B_{RP}$ at $T_A = 25^\circ\text{C}$	-270	-170	-150	-50	-180	-100	-230	-50
over operating temp. range	-300	-140	-175	-50	-200	-80	-250	-50
$B_{hys}$ at $T_A = 25^\circ\text{C}$	340	540	100	300	200	360	100	460
over operating temp. range	280	600	100	350	160	400	100	500

NOTES:  $B_{OP}$  = operate point (output turns ON);  $B_{RP}$  = release point (output turns OFF);  $B_{hys}$  = hysteresis ( $B_{OP} - B_{RP}$ ).

As used here, negative flux densities are defined as less than zero (algebraic convention).

\*Complete part number includes a suffix to identify operating temperature range (E or L) and package type (LT, U, or UA).



115 Northeast Cutoff, Box 15036  
Worcester, Massachusetts 01615-0036 (508) 853-5000  
Copyright © 1995, 1999, Allegro MicroSystems, Inc.

# 3185 THRU 3189 HALL-EFFECT LATCHES FOR HIGH-TEMPERATURE OPERATION

## TYPICAL OPERATING CHARACTERISTICS

**A3185\* SWITCH POINTS**

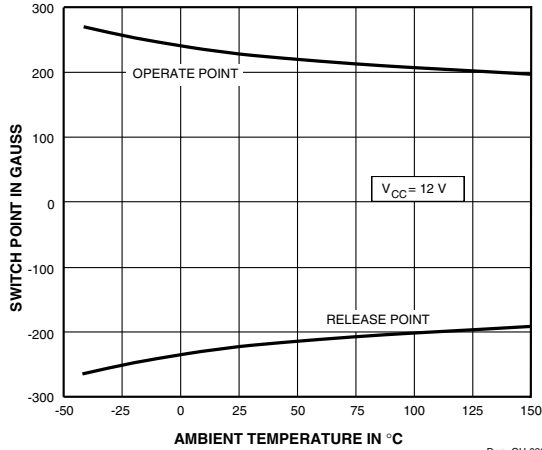

Dwg. GH-026

**A3187\* SWITCH POINTS**

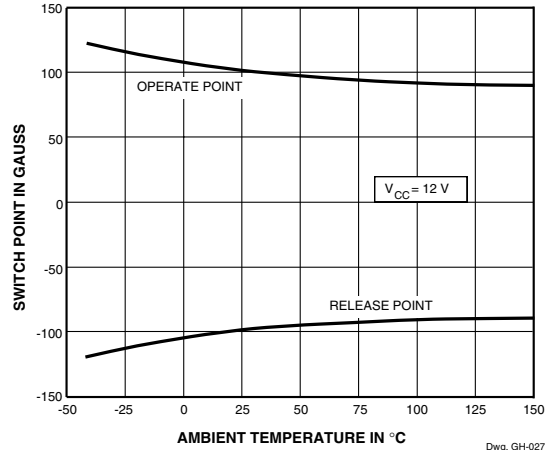

Dwg. GH-027

**OUTPUT SATURATION VOLTAGE**

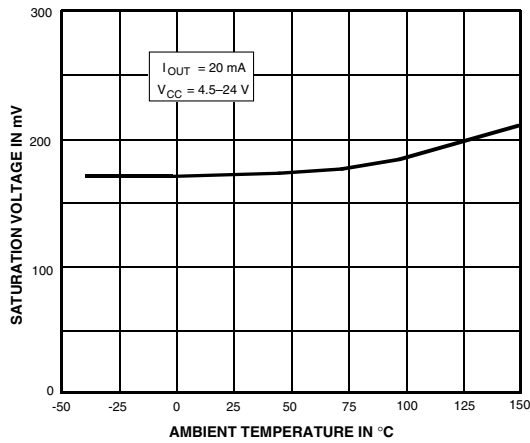

Dwg. GH-029

**SUPPLY CURRENT**

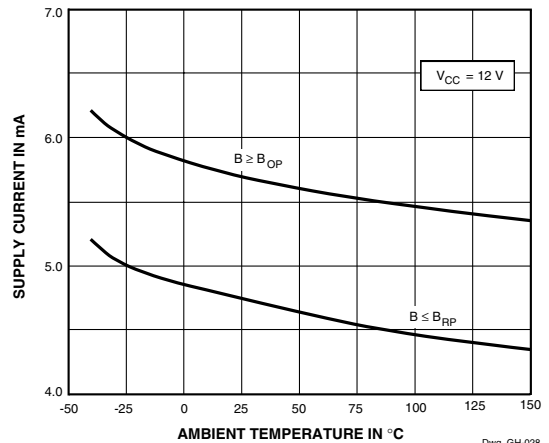

Dwg. GH-028

**SUPPLY CURRENT**

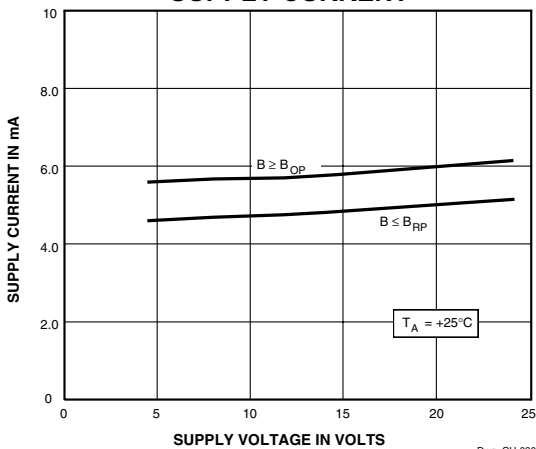

Dwg. GH-030

**OPERATE POINT**

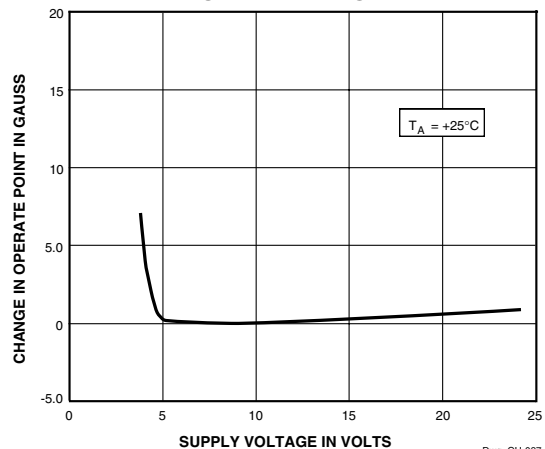

Dwg. GH-037

\* Complete part number includes a suffix denoting operating temperature range (E or L) and package type (LT, U, or UA).

# 3185 THRU 3189 HALL-EFFECT LATCHES FOR HIGH-TEMPERATURE OPERATION

## SENSOR LOCATIONS

( $\pm 0.005$ " [0.13 mm] die placement)

### Package Designators "LT"

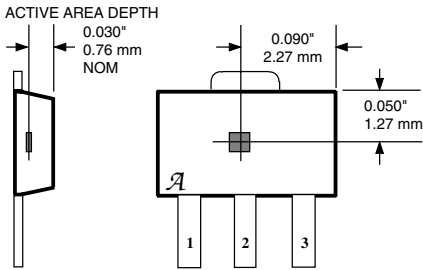

Dwg. MH-008-4B

### Package Designator "U"

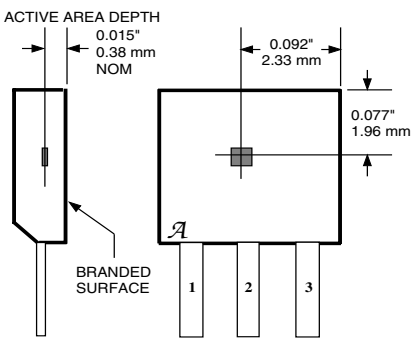

Dwg. MH-002-7B

### Package Designators "UA" and "UA-TL"

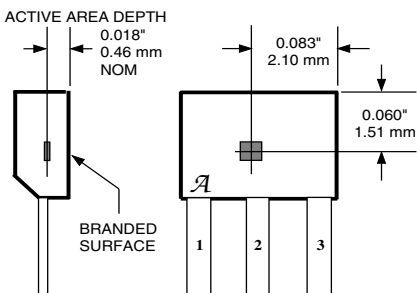

Dwg. MH-011-4B

Although sensor location is accurate to three sigma for a particular design, product improvements may result in small changes to sensor location.

## OPERATION

In operation, the output transistor is OFF until the strength of the magnetic field perpendicular to the surface of the chip exceeds the threshold or operate point ( $B_{OP}$ ). When the field strength exceeds  $B_{OP}$ , the output transistor switches ON and is capable of sinking 25 mA of current.

The output transistor switches OFF when magnetic field reversal results in a magnetic flux density below the OFF threshold ( $B_{RP}$ ). This is illustrated in the transfer characteristics graph (A3187\* shown).

Note that the device latches; that is, a south pole of sufficient strength will turn the device ON. Removal of the south pole will leave the device ON. The presence of a north pole of sufficient strength is required to turn the device OFF.

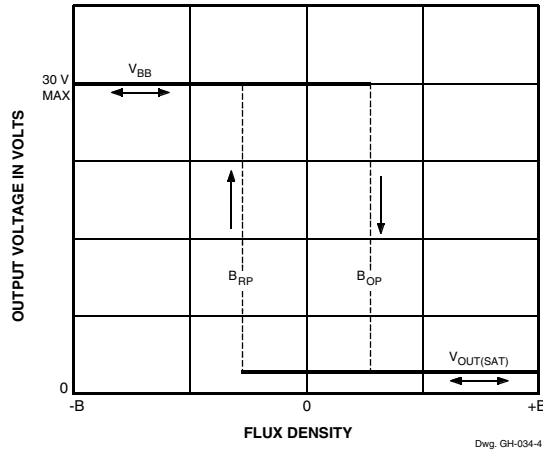

Dwg. GH-034-4

The simplest form of magnet that will operate these devices is a ring magnet, as shown below. Other methods of operation are possible.

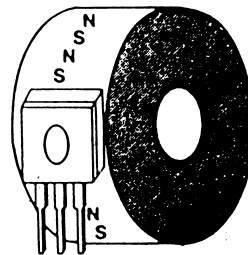

Dwg. A-11,899

## APPLICATIONS INFORMATION

Extensive applications information on magnets and Hall-effect sensors is also available in the *Allegro Integrated and Discrete Semiconductors Data Book* or *Application Note 27701*.

# 3185 THRU 3189 HALL-EFFECT LATCHES FOR HIGH-TEMPERATURE OPERATION

## PACKAGE DESIGNATOR 'U'

**Dimensions in Inches**  
(controlling dimensions)

**Dimensions in Millimeters**  
(for reference only)

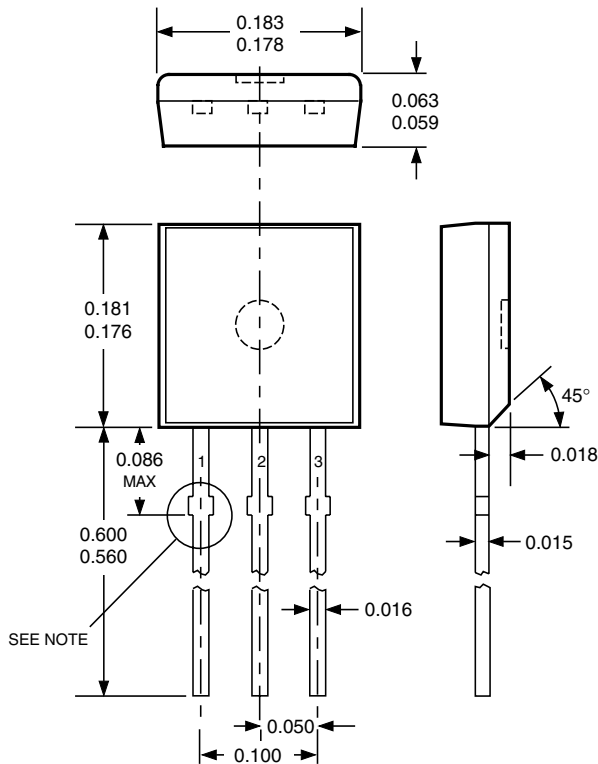

Dwg. MH-003D in

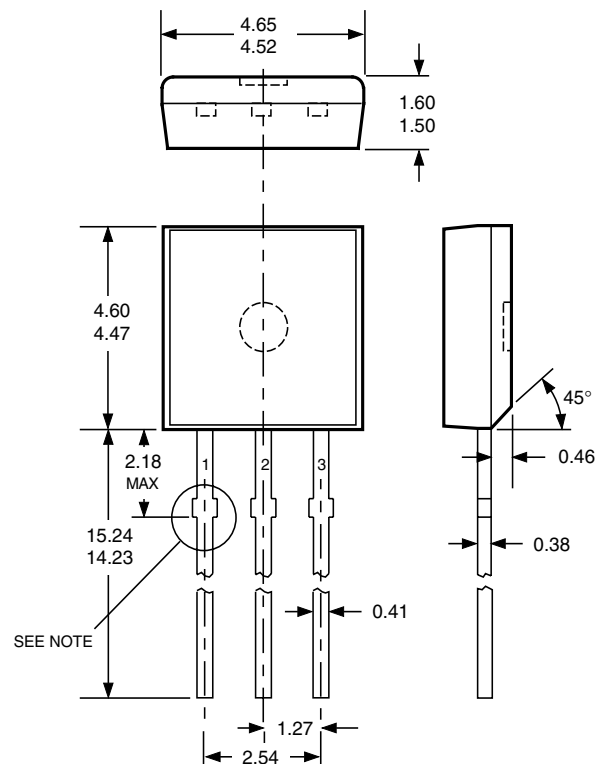

Dwg. MH-003D mm

**Devices in the 'U' package are  
NOT RECOMMENDED FOR NEW DESIGN**

- NOTES: 1. Tolerances on package height and width represent allowable mold offsets. Dimensions given are measured at the widest point (parting line).
2. Exact body and lead configuration at vendor's option within limits shown.
3. Height does not include mold gate flash.
4. Recommended minimum PWB hole diameter to clear transition area is 0.035" (0.89 mm).
5. Where no tolerance is specified, dimension is nominal.
6. Minimum lead length was 0.500" (12.70 mm). If existing product to the original specifications is not acceptable, contact sales office before ordering.

# 3185 THRU 3189 HALL-EFFECT LATCHES FOR HIGH-TEMPERATURE OPERATION

## PACKAGE DESIGNATOR 'UA'

**Dimensions in Inches**  
(controlling dimensions)

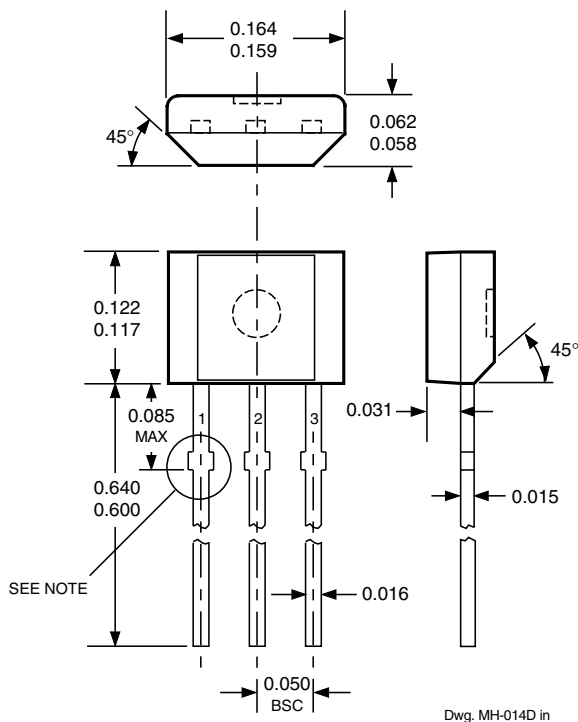

**Dimensions in Millimeters**  
(for reference only)

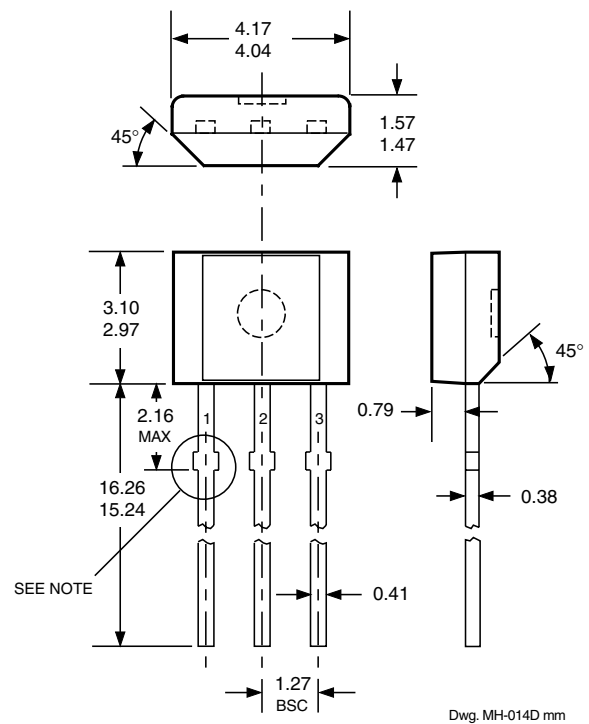

## Surface-Mount Lead Form (Suffix '-TL')

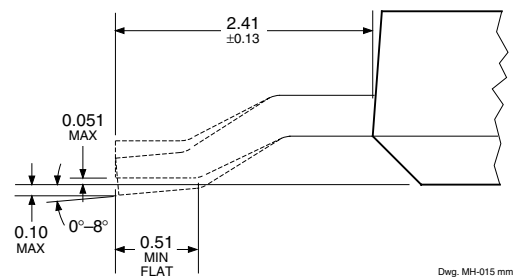
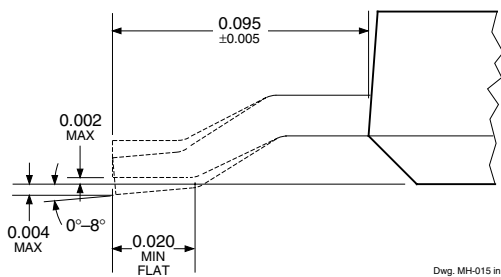

- NOTES: 1. Tolerances on package height and width represent allowable mold offsets. Dimensions given are measured at the widest point (parting line).
2. Exact body and lead configuration at vendor's option within limits shown.
3. Height does not include mold gate flash.
4. Recommended minimum PWB hole diameter to clear transition area is 0.035" (0.89 mm).
5. Where no tolerance is specified, dimension is nominal.

# 3185 THRU 3189 HALL-EFFECT LATCHES FOR HIGH-TEMPERATURE OPERATION

## PACKAGE DESIGNATOR 'LT' (SOT-89/TO-243AA)

**Dimensions in Inches**  
(for reference only)

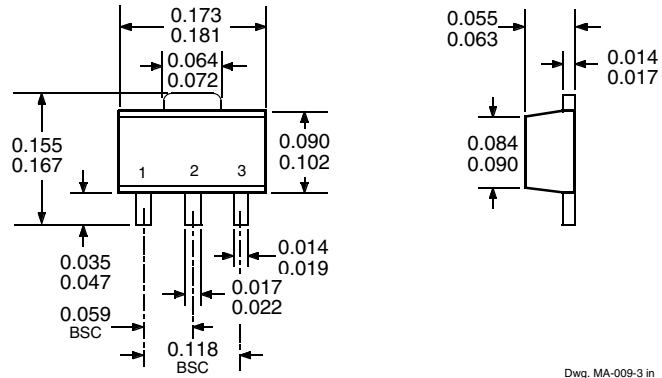

**Dimensions in Millimeters**  
(controlling dimensions)

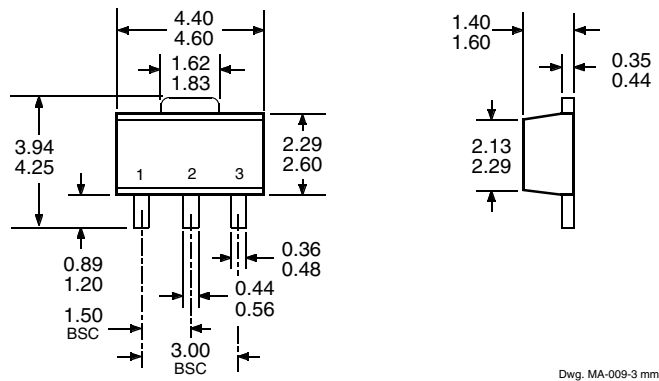

NOTE: Exact body and lead configuration at vendor's option within limits shown.

*Allegro MicroSystems, Inc. reserves the right to make, from time to time, such departures from the detail specifications as may be required to permit improvements in the design of its products.*

*The information included herein is believed to be accurate and reliable. However, Allegro MicroSystems, Inc. assumes no responsibility for its use; nor for any infringements of patents or other rights of third parties which may result from its use.*

**3185 THRU 3189**  
**HALL-EFFECT LATCHES**  
**FOR HIGH-TEMPERATURE**  
**OPERATION**

**HALL-EFFECT SENSORS SELECTION GUIDE**

Partial Part Number	Avail. Oper. Temp.	Characteristics at T <sub>A</sub> = +25°C			Features	Notes
		B <sub>OP</sub> (max)	B <sub>RP</sub> (min)	B <sub>hys</sub> (typ)		
<b>HALL-EFFECT UNIPOLAR SWITCHES in order of B<sub>OP</sub> and B<sub>hys</sub></b>						
3240	E/L	+50	+5.0	10	chopper stabilized	1
3210	E	±70	±5.0	7.7	micropower, chopper stabilized	
3361	E	+120	+50	5.0*	2-wire, chopper stabilized	
3362	E	+120	+50	5.0*	2-wire, chopper stabilized	
3161	E	+160	+30	20	2-wire	
3141	E/L	+160	+10	55		
3235	S	+175	+25	15*	output 1	2
		-25	-175	15*	output 2	2
5140	E	+200	+50	55	300 mA output	1, 3
3142	E/L	+230	+75	55		
3143	E/L	+340	+165	55		
3144	E/L	+350	+50	55		
3122	E/L	+400	+140	105		
3123	E/L	+440	+180	105		
3121	E/L	+450	+125	105		
3150	J	+40 to +850	-	20	programmable, chopper stabilized	1
<b>HALL-EFFECT LATCHES &amp; BIPOLAR SWITCHES<sup>†</sup> in order of B<sub>OP</sub> and B<sub>hys</sub></b>						
3260	E/L	+30	-30	20	bipolar, chopper stabilized	
3280	E/L	+40	-40	45	chopper stabilized	
3134	E/L	+50	-50	27	bipolar switch	
3133	K/L/S	+75	-75	52	bipolar switch	
3281	E/L	+90	-90	100	chopper stabilized	
3132	K/L/S	+95	-95	52	bipolar switch	
3187	E/L	+150	-150	100*		
3177	S	+150	-150	200		
3625	S	+150	-150	200	900 mA outputs	1, 3, 5
3626	S	+150	-150	200	400 mA outputs	1, 3, 5
3195	E/L	+160	-160	220		1, 4
3197	L	+160	-160	230		1
3175	S	+170	-170	200		
3188	E/L	+180	-180	200*		
3283	E/L	+180	-180	300	chopper stabilized	
3189	E/L	+230	-230	100*		
3275	S	+250	-250	100*		5
3185	E/L	+270	-270	340*		

Operating Temperature Ranges:

S = -20°C to +85°C, E = -40°C to +85°C, J = -40°C to +115°C, K = -40°C to +125°C, L = -40°C to +150°C

Notes 1. Protected.

2. Output 1 switches on south pole, output 2 switches on north pole for 2-phase, bifilar-wound, unipolar-driven brushless dc motor control.

3. Power driver output.

4. Active pull down.

5. Complementary outputs for 2-phase bifilar-wound, unipolar-driven brushless dc motor control.

\* Minimum.

† Latches will not switch on removal of magnetic field; bipolar switches may switch on removal of field but require field reversal for reliable operation over operating temperature range.



115 Northeast Cutoff, Box 15036  
Worcester, Massachusetts 01615-0036 (508) 853-5000