

PROTECTED POWERHALL® SENSOR — LAMP/SOLENOID DRIVER

The UGQ5140K unipolar Hall effect switch is a monolithic integrated circuit designed for magnetic actuation of low-power incandescent lamps or inductive loads such as relays or solenoids. Included on chip is a Darlington output that is capable of continuously sinking in excess of 300 mA. Internal protection circuitry limits surge (lamp turn-ON) or fault currents to approximately 900 mA. A sensitive magnetic threshold allows the device to be used in conjunction with inexpensive magnets or in applications that require relatively large operating distances.

Each sensor/driver includes a magnetic sensing Hall voltage generator, operational amplifier, Schmitt trigger, voltage regulator, and an open-collector, high-gain Darlington power output stage. The regulator allows use of the device with supply voltages of 4.5 V to 28 V. On-chip compensation circuitry stabilizes switch-point performance over temperature. The magnetic operation of this device is similar to that of the A3141E— Hall-effect switch.

The sensitive magnetic switch point coupled with the power output, current limiting, and thermal limiting circuitry allow the UGQ5140K to magnetically actuate various loads without requiring any external components.

The UGQ5140K is rated for operation over an extended temperature range of -40°C to +85°C. It is supplied in a four-pin mini-SIP plastic package, 0.200" (5.08 mm) wide, 0.130" (3.30 mm) high, and 0.060" (1.54 mm) thick.

FEATURES

- Magnetically Actuated Power Switch
- Temperature-Compensated Switch Points
- High Current-Sink Capability
 - 300 mA Continuous
 - 900 mA Peak Current Limit
- Output Short-Circuit Protection
- Low Quiescent Standby Current
- Linear Thermal Limiting
- Automotive Temperature Range
 - 40°C to +85°C, Operating
- Internal Inductive Flyback/Clamp Diode Protection
- Reverse Battery Protection
- Low-Profile 4-Pin Mini-SIP

Always order by complete part number: **UGQ5140K**.

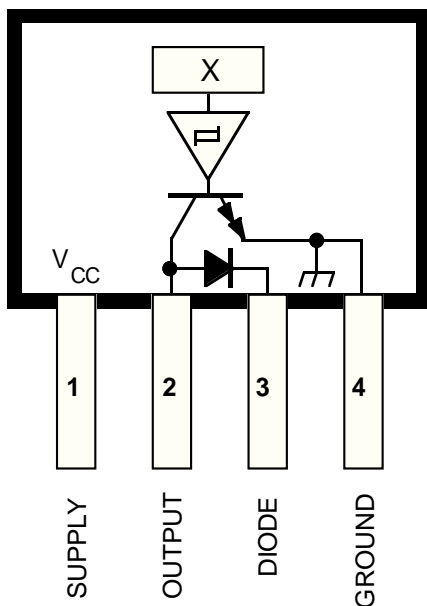

Dwg. PH-001

Pinning is shown viewed from branded side.

ABSOLUTE MAXIMUM RATINGS at $T_A = +25^\circ\text{C}$

Supply Voltage, V_{CC}	28 V
Reverse Battery Voltage, V_{RCC}	-45 V
Output OFF Voltage, V_{OUT}	45 V
Over-Current Protected Output Voltage, V_{OUT}	25 V
Output ON Current, I_{OUT}	900 mA*
Magnetic Flux Density, B	Unlimited
Package Power Dissipation, P_D	See Graph
Operating Temperature Range, T_A	-40°C to +85°C
Storage Temperature Range, T_S	-65°C to +150°C

* Output is current limited at approximately 900 mA and junction temperature limited if current in excess of 900 mA is attempted. See Circuit Description and Applications for further information.

5140 PROTECTED POWERHALL[®] SENSOR: LAMP/SOLENOID DRIVER

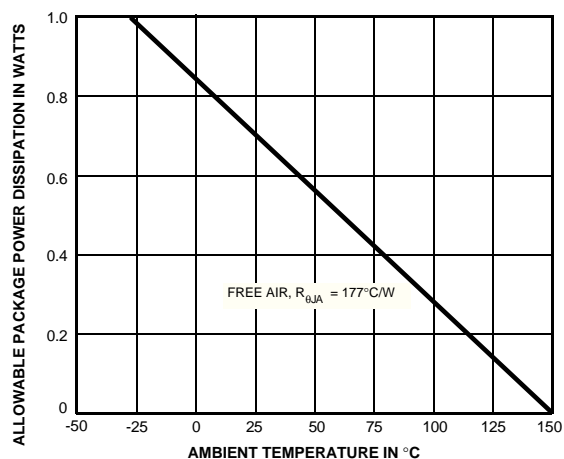
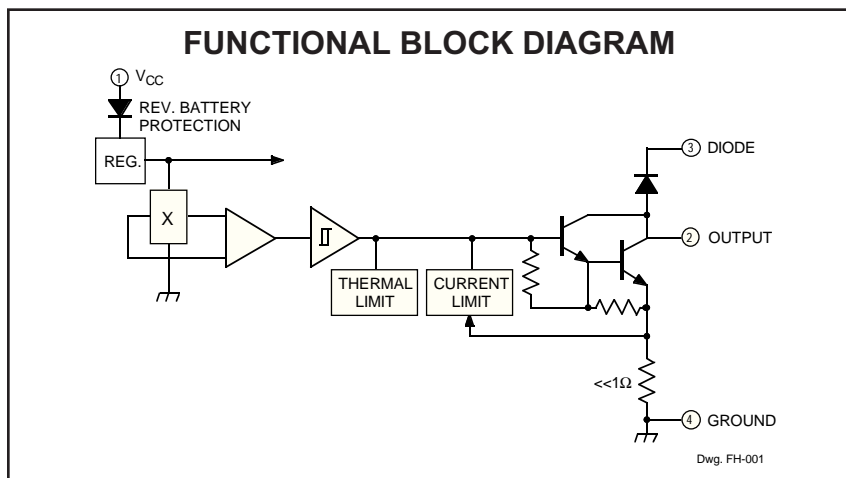

ELECTRICAL CHARACTERISTICS at $T_A = -40^\circ\text{C}$ to $+85^\circ\text{C}$, $V_{CC} = 4.5\text{ V}$ to 24 V (unless otherwise noted).

Characteristic	Symbol	Test Conditions	Limits			Units
			Min.	Typ.	Max.	
Supply Voltage Range	V_{CC}	Operating	4.5	12	24	V
Output Leakage Current	I_{OUT}	$V_{OUT} = 24\text{ V}$	—	<1.0	10	μA
Output Sustaining Voltage	$V_{OUT(SUS)}$	$I_{OUT} = 100\text{ mA}$	35	—	—	V
Output Saturation Voltage	$V_{OUT(SAT)}$	$I_{OUT} = 300\text{ mA}$, $V_{CC} = 24\text{ V}$	—	0.84	1.2	V
Over-Current Limit	I_{LIMIT}	$V_{CC} = V_{OUT} = 12\text{ V}$, $B \geq 500\text{ G}$	—	900	—	mA
Output Rise Time	t_r	$V_{CC} = 12\text{ V}$, $V_{BB} = 18\text{ V}$, $R_L = 1.1\text{ k}\Omega$, $C_L = 20\text{ pF}$	—	0.04	2.0	μs
Output Fall Time	t_f		—	0.04	2.0	μs
Supply Current	I_{CC}	Output OFF	—	5.5	10	mA
Diode Forward Voltage	V_F	$I_F = 300\text{ mA}$	—	1.1	1.5	V
Diode Leakage Current	I_R	$V_R = 35\text{ V}$	—	<1.0	50	μA
Thermal Limit	T_{LIMIT}	$V_{CC} = V_{OUT} = 12\text{ V}$, $B \geq 500\text{ G}$, $I_{OUT} = 10\text{ mA}$	—	165	—	$^\circ\text{C}$

Typical Data is at $T_A = +25^\circ\text{C}$ and is for design information only.

MAGNETIC CHARACTERISTICS at $V_{CC} = 4.5\text{ V}$ to 24 V .

Characteristic	Symbol	$T_A = +25^\circ\text{C}$			$T_A = -40^\circ\text{C}$ to $+85^\circ\text{C}$			Units
		Min.	Typ.	Max.	Min.	Typ.	Max.	
Magnetic Operate Point	B_{OP}	70	155	200	45	—	240	G
Magnetic Release point	B_{RP}	50	100	180	25	—	220	G
Hysteresis	B_{hys}	20	55	—	20	—	—	G



5140
PROTECTED POWERHALL[®]
SENSOR:
LAMP/SOLENOID DRIVER

TYPICAL OPERATING CHARACTERISTICS

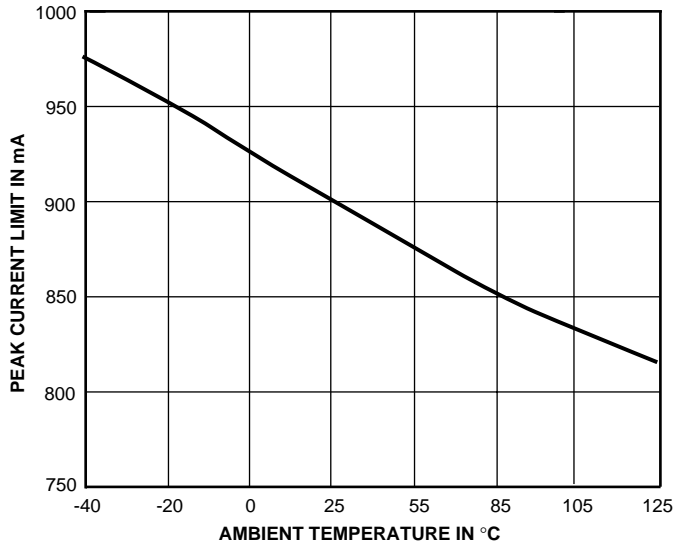

Dwg. GH-004

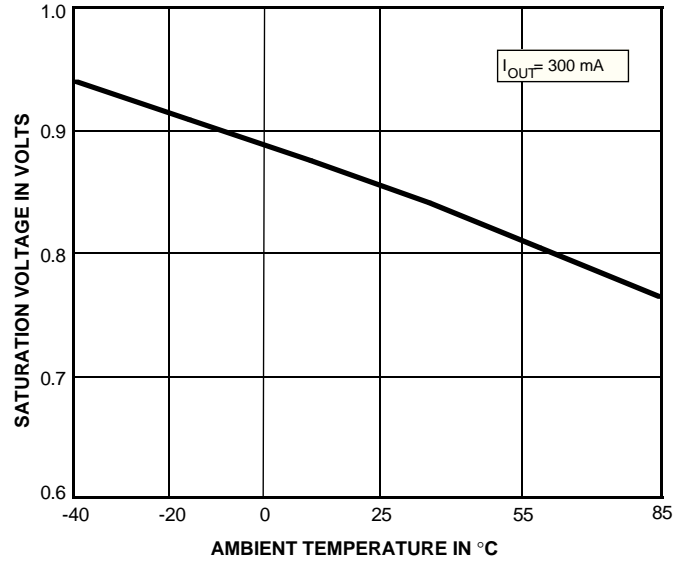

Dwg. GH-002A

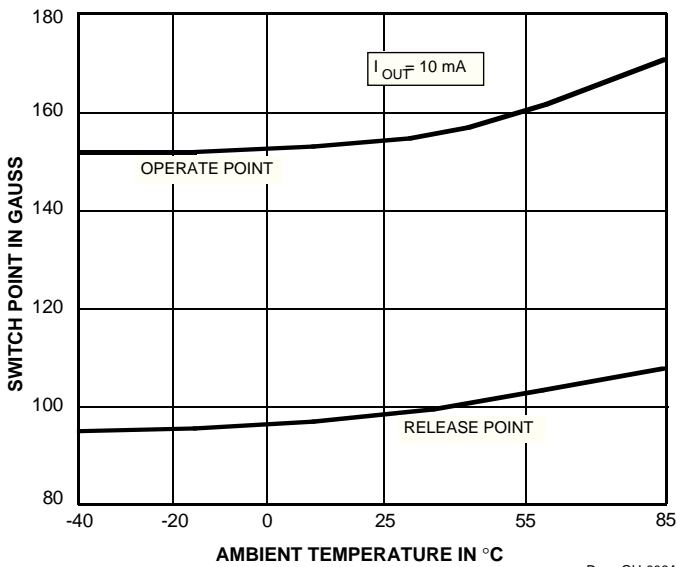

Dwg. GH-006A

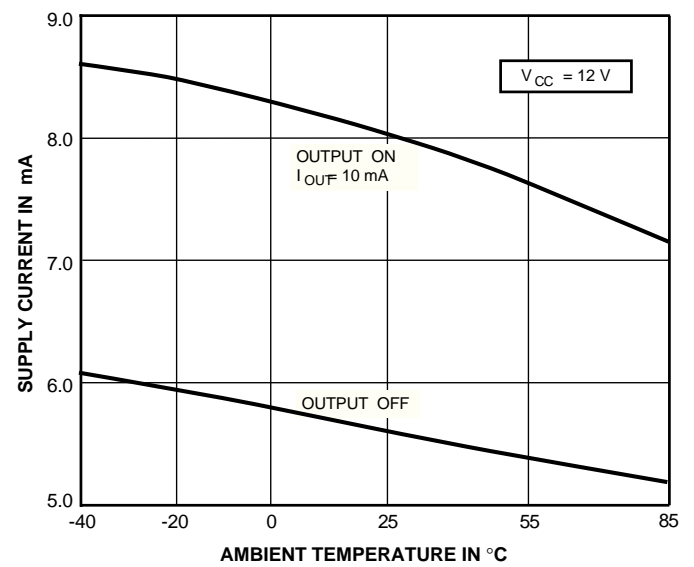

Dwg. GH-003A

5140
PROTECTED POWERHALL®
SENSOR:
LAMP/SOLENOID DRIVER

TYPICAL TRANSFER CHARACTERISTICS
at $T_A = +25^\circ\text{C}$

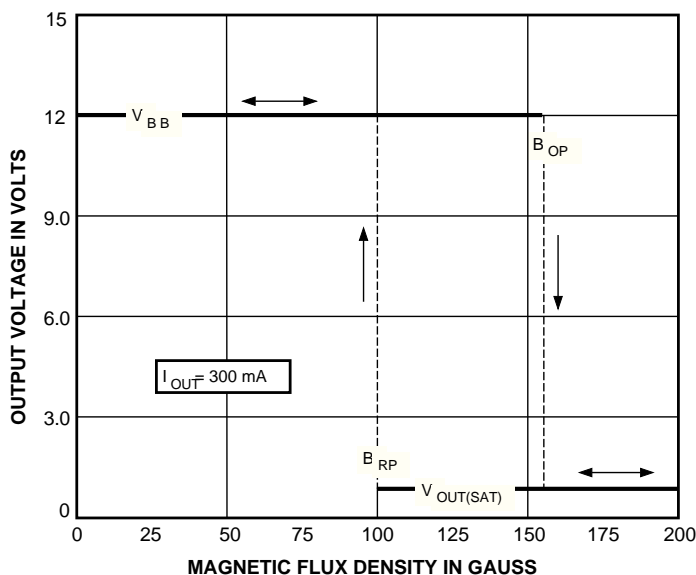

Dwg. GH-007

CIRCUIT DESCRIPTION AND OPERATION

The UGQ5140K merges state-of-the-art Hall effect sensing and power driving technologies to allow precision non-contact actuation of incandescent lamps or inductive loads. It is rated for operation over an extended temperature range as typically required in automotive applications.

MAGNETIC OPERATION

As shown in the Transfer Characteristics graph, the output of the device (pin 2) switches low when the magnetic field at the Hall sensor exceeds the operate point threshold (B_{OP}). At this point, the output voltage is $V_{OUT(SAT)}$. When the magnetic field is reduced to below the release point threshold (B_{RP}), the device output goes high. The difference in the magnetic operate and release points is called the hysteresis (B_H) of the part. This built-in hysteresis allows clean switching of the output even in the presence of external mechanical vibration and electrical noise.

CURRENT AND THERMAL LIMITING

Output short circuits may be caused by faulty connectors, crimped wiring harnesses, or blown loads. In such cases, current and thermal limit circuitry will protect the output transistor against destruction.

Current through the output transistor is sensed with a low-value on-chip aluminum resistor. The voltage drop across this resistor is fed back to control the base drive of the output stage. This feedback prevents the output transistor from exceeding its maximum current density rating by limiting the output current to approximately 900 mA. It may also cause the output voltage to increase ($V_{OUT} = V_{BB} - [I_{LIMIT} \times R_L]$). In this mode, the device will dissipate an increased amount of power ($P_D = V_{OUT} \times I_{LIMIT}$) and the output transistor will be thermally stressed.

5140
PROTECTED POWERHALL[®]
SENSOR:
LAMP/SOLENOID DRIVER

This stress, unless protected against (as in the UGQ5140K), will cause the device junction temperature to rise until it fails catastrophically.

Thermal stress protection is provided in two manners; delta temperature protection, and junction temperature protection. Under worst-case conditions (see Figures 1 and 2), if the output is shorted to supply, the output transistor will heat up much faster than the rest of the integrated circuit. This condition could cause localized failure in the output transistor. To prevent damage, a delta temperature limiting scheme is used. If a large thermal gradient is sensed across the device, the output transistor base drive is reduced to lower the output current. This reduces the power (heat) generated by the output transistor.

When thermal stresses cause the junction temperature to reach approximately +165°C, a linear thermal limiting circuit is activated. This circuit linearly reduces the base drive of the output transistor to maintain a constant junction temperature of 165°C. In this mode, the output current will be a function of the heat dissipating characteristics of the package and its environment. Linear thermal limiting eliminates the low-frequency thermal oscillation problems experienced by thermal shutdown (ON-OFF) schemes.

The output characteristics are shown in Figures 1 and 2. Note the three distinct operating regions: peak limit, delta limit, and thermal limit. In practice the output voltage and current may exhibit some oscillations during peak current limiting due to output load characteristics. These oscillations are of very-short duration (typically 50 ms) and may be damped with an external capacitor between pins 2 and 4.

When the fault condition that caused the output overload is corrected, the device returns to normal operating mode.

FIGURE 1
OUTPUT CURRENT UNDER SHORT-CIRCUIT CONDITIONS

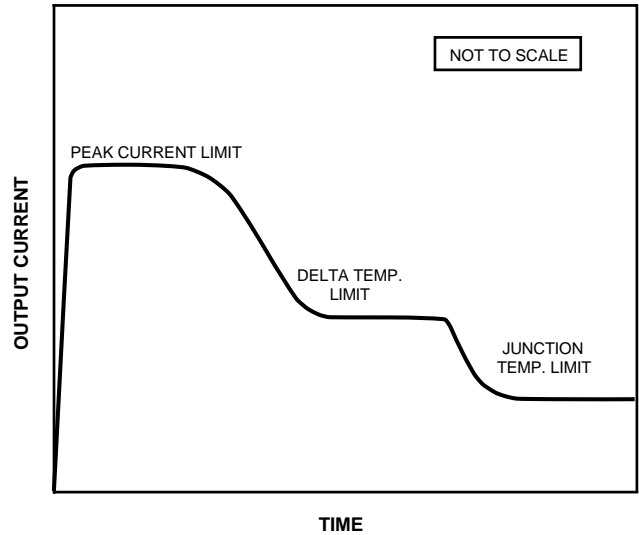
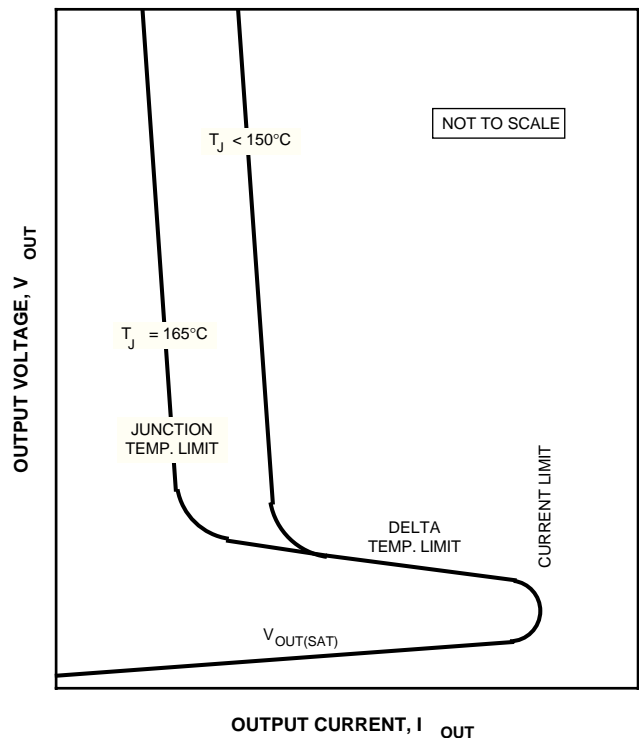

FIGURE 2
OUTPUT VOLTAGE vs OUTPUT CURRENT



5140
PROTECTED POWERHALL®
SENSOR:
LAMP/SOLENOID DRIVER

FIGURE 3
TYPICAL LAMP DRIVER APPLICATION

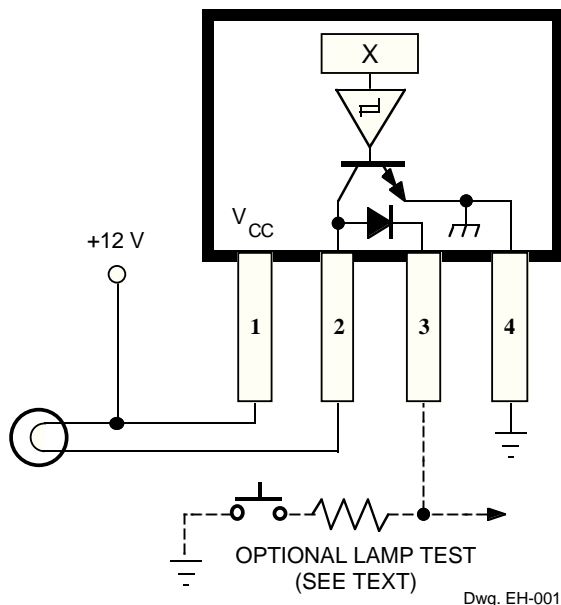
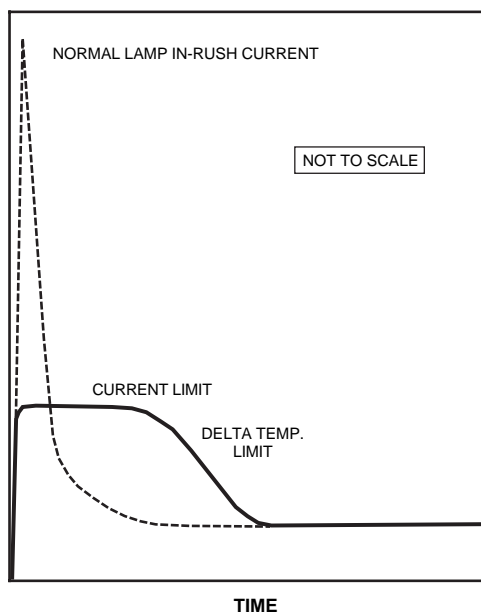

FIGURE 4
LAMP CURRENT vs TIME



TYPICAL APPLICATIONS

INCANDESCENT LAMP DRIVER

High incandescent lamp turn-ON currents (commonly called in-rush currents) can contribute to poor lamp reliability and destroy semiconductor lamp drivers. Warming resistors protect both driver and lamp but use significant power when the lamp is OFF while current-limiting resistors waste power when the lamp is ON. Lamps with steady-state current ratings to 300 mA can be driven by the UGQ5140K (Figure 3) without the need for warming or current limiting resistors. In applications using several sensor/drivers to control multiple lamps, the internal clamp diodes may be connected together to an appropriate current-limiting resistor and simple "lamp test" switch.

As shown in Figure 4, when an incandescent lamp is initially turned ON, the cold filament is at minimum resistance and will normally allow a 10x to 12x peak in-rush current. As the lamp warms up, the filament resistance increases to its rated value and the lamp current is reduced to its steady-state rating. When switching a lamp with the UGQ5140K, the internal current-limiting circuitry limits the peak current to approximately 900 mA. The device will stay in the current limit and delta temperature limit modes until the lamp resistance increases to its rated steady-state value (Figure 4). A side-effect of this current-limiting feature is that lamp turn-on times will increase. Typical lamp turn-on times are shown in Figure 5.

INDUCTIVE LOAD DRIVER

Connecting the internal clamp diode (pin 3) to the positive supply allows relays or other inductive loads to be driven directly, as shown in Figure 6. The internal diode prevents damage to the output transistor by clamping the high-voltage spikes which occur when turning OFF an inductive load. An optional external Zener diode can be used to increase the flyback voltage, providing a much faster inductive load turn-OFF current decay, resulting in faster dropout (reduced relay contact arcing), and improved performance. The maximum Zener voltage, plus the load supply voltage, plus the clamp diode forward voltage should not exceed 35 volts.

5140
PROTECTED POWERHALL[®]
SENSOR:
LAMP/SOLENOID DRIVER

FIGURE 5
LAMP TURN-ON TIME

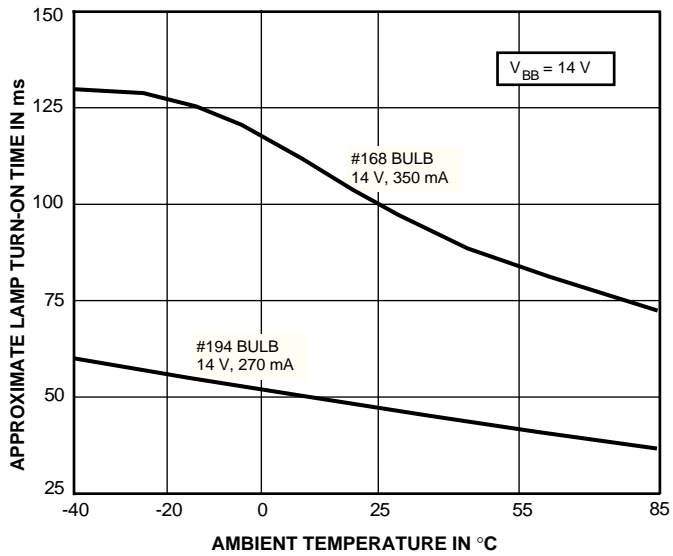

Dwg. GH-005A

SENSOR LOCATION

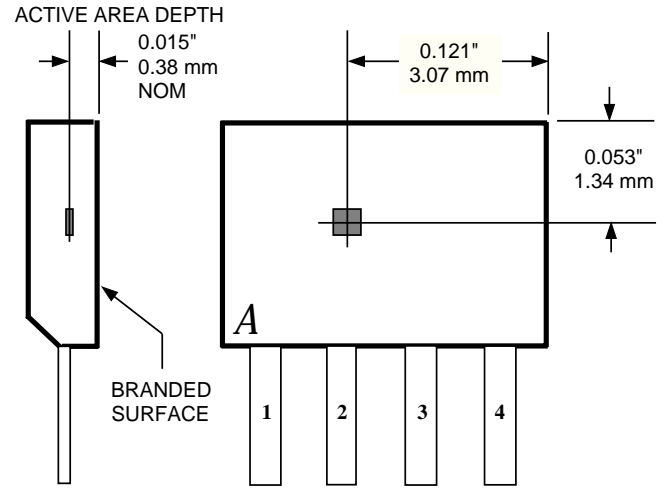

Dwg. MH-001B

FIGURE 6
TYPICAL RELAY/SOLENOID DRIVER APPLICATION

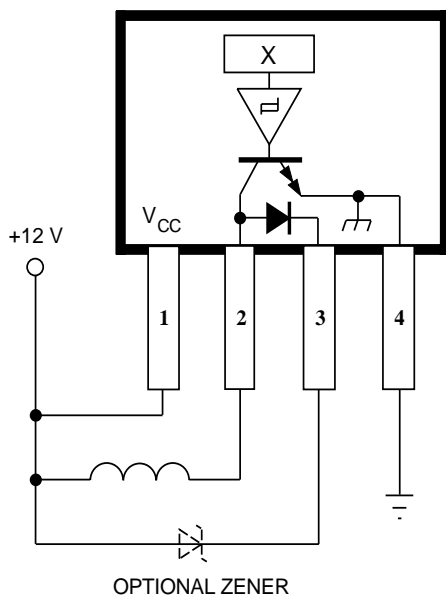

Dwg. EH-002

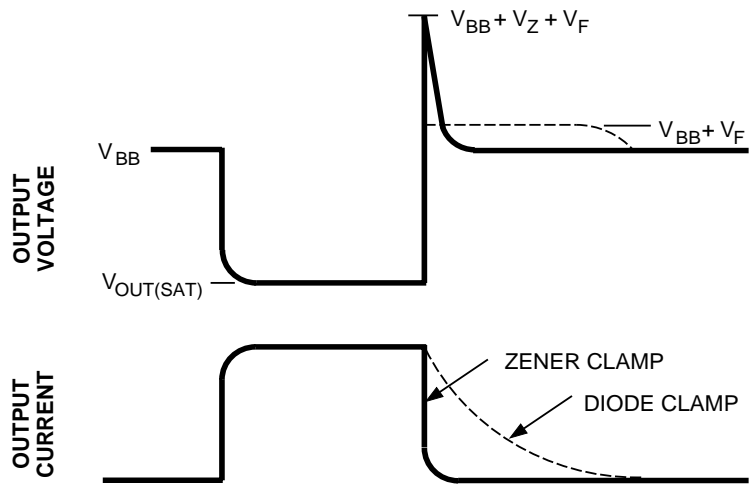

Dwg. WP-001-1

5140

PROTECTED POWERHALL[®]

SENSOR:

LAMP/SOLENOID DRIVER

Dimensions in Inches (controlling dimensions)

Dimensions in Millimeters (for reference only)

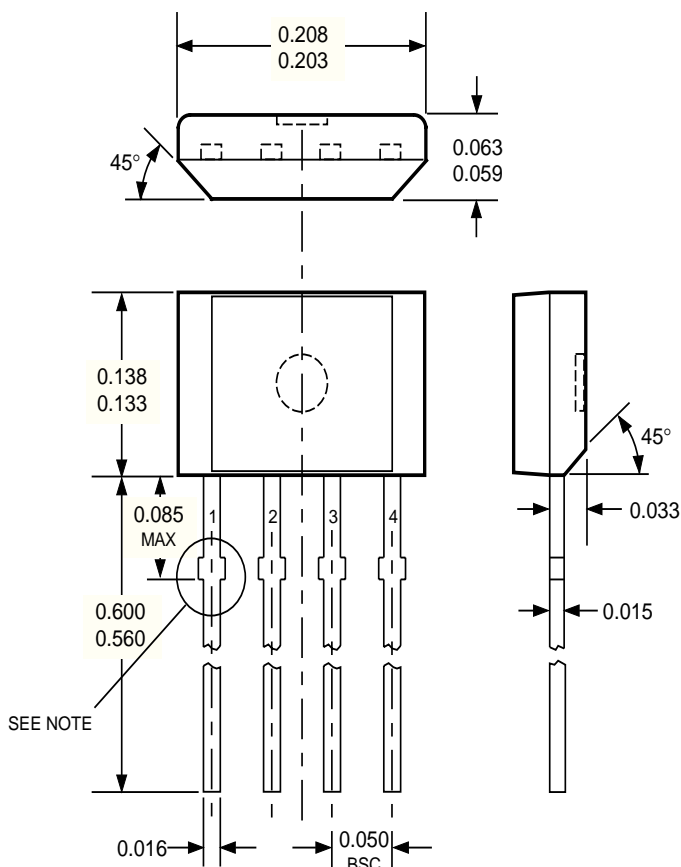

Dwg. MH-009C in

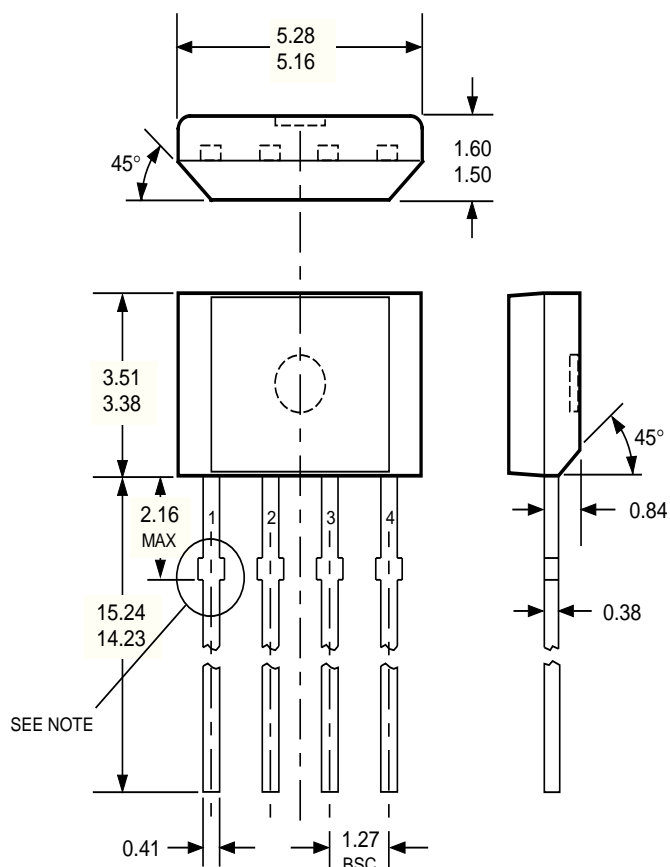

Dwg. MH-009C mm

- NOTES:
1. Tolerances on package height and width represent allowable mold offsets. Dimensions given are measured at the widest point (parting line).
 2. Exact body and lead configuration at vendor's option within limits shown.
 3. Height does not include mold gate flash.
 4. Recommended minimum PWB hole diameter to clear transition area is 0.035" (0.89 mm).
 5. Where no tolerance is specified, dimension is nominal.

Allegro MicroSystems, Inc. reserves the right to make, from time to time, such departures from the detail specifications as may be required to permit improvements in the design of its products.

The information included herein is believed to be accurate and reliable. However, Allegro MicroSystems, Inc. assumes no responsibility for its use; nor for any infringements of patents or other rights of third parties which may result from its use.