

6277

PRELIMINARY INFORMATION 8-BIT SERIAL-INPUT, CONSTANT-CURRENT LATCHED LED DRIVER

(Subject to change without notice)
July 20, 2000

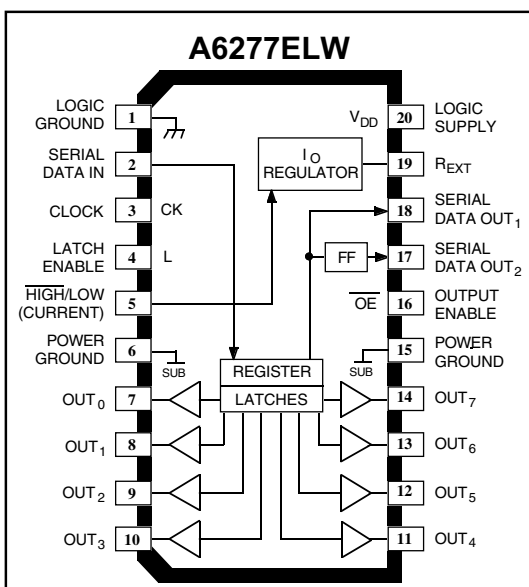

Dwg. PP-029-17A

Note that the A6277EA (DIP) and the A6277ELW (SOIC) are electrically identical and share a common terminal number assignment.

ABSOLUTE MAXIMUM RATINGS

Supply Voltage, V_{DD}	7.0 V
Output Voltage Range, V_O	-0.5 V to +24 V
Output Current, I_O	150 mA
Input Voltage Range, V_I	-0.4 V to $V_{DD} + 0.4$ V
Package Power Dissipation, P_D	See Graph
Operating Temperature Range, T_A	
Suffix 'S-'	-20°C to +85°C
Suffix 'E-'	-40°C to +85°C
Storage Temperature Range, T_S	-55°C to +150°C

Caution: These CMOS devices have input static protection (Class 2) but are still susceptible to damage if exposed to extremely high static electrical charges.

The A6277x is specifically designed for LED-display applications. Each BiCMOS device includes an 8-bit CMOS shift register, accompanying data latches, and eight npn constant-current sink drivers. Two package styles and two operating temperature ranges are available.

The CMOS shift register and latches allow direct interfacing with microprocessor-based systems. With a 5 V logic supply, typical serial data-input rates are up to 20 MHz. The LED drive current is determined by the user's selection of a single resistor. A CMOS serial data output permits cascade connections in applications requiring additional drive lines. For inter-digit blanking, all output drivers can be disabled with an ENABLE input high. In addition, a HIGH/LOW function enables full selected current with the application of a logic low, or 50% selected current with the application of a logic high.

The first character of the part number suffix determines the device operating temperature range. Suffix 'E-' is for -40°C to +85°C, and suffix 'S-' is -20°C to +85°C. Two package styles are provided for through-hole DIP (suffix '-A') or surface-mount SOIC (suffix '-LW') applications. The copper lead frame and low logic-power dissipation allow the dual in-line package to sink 122 mA through all outputs continuously over the operating temperature range (1.0 V drop, +85°C).

FEATURES

- To 150 mA Constant-Current Outputs
- 24 V Outputs
- Under-Voltage Lockout
- Low-Power CMOS Logic and Latches
- High Data Input Rate
- Similar to Toshiba TD62715FN
- High/Low Output Current Function

Always order by complete part number, e.g., **A6277EA**.

6277

8-BIT SERIAL-INPUT, CONSTANT-CURRENT LATCHED LED DRIVER

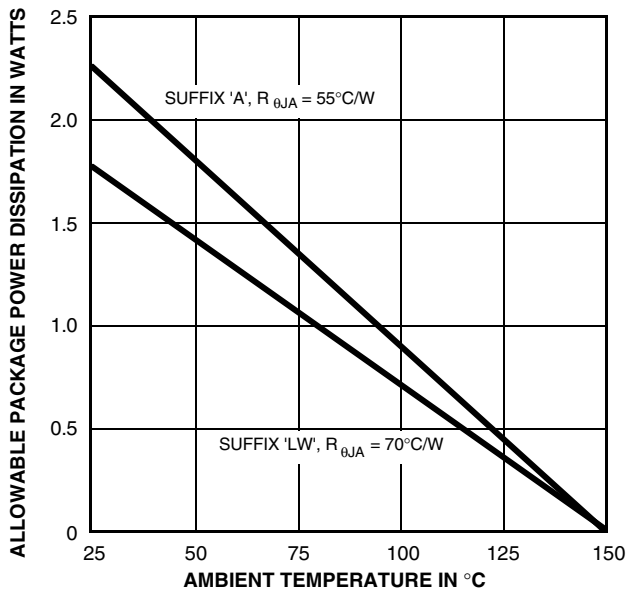

Dwg. GP-018-1

FUNCTIONAL BLOCK DIAGRAM

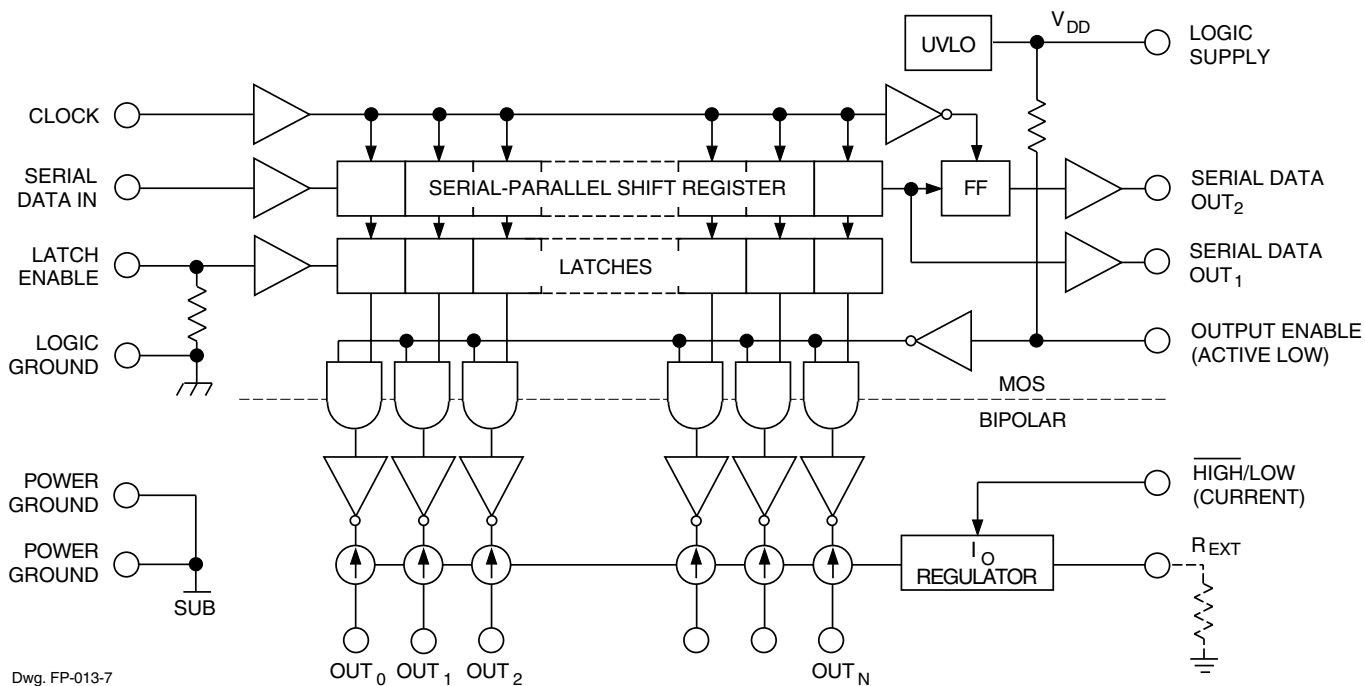

Dwg. FP-013-7

6277
8-BIT SERIAL-INPUT,
CONSTANT-CURRENT
LATCHED LED DRIVER

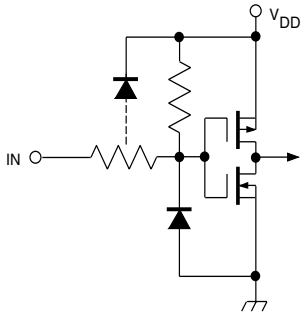

Dwg. EP-010-6

OUTPUT ENABLE (active low)

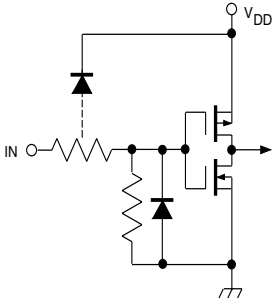

Dwg. EP-010-7

LATCH ENABLE and HIGH/LOW

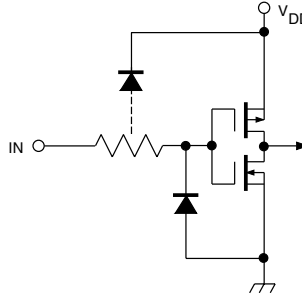

Dwg. EP-010-5

CLOCK and SERIAL DATA IN

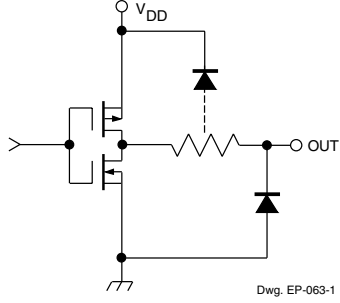

Dwg. EP-063-1

SERIAL DATA OUT

TRUTH TABLE

Serial Data Input	Clock Input	Shift Register Contents						Serial Data Output	Latch Enable Input	Latch Contents						Output Enable Input	Output Contents					
		I ₁	I ₂	I ₃	...	I _{N-1}	I _N			I ₁	I ₂	I ₃	...	I _{N-1}	I _N		I ₁	I ₂	I ₃	...	I _{N-1}	I _N
H	⌋	H	R ₁	R ₂	...	R _{N-2}	R _{N-1}	R _{N-1}														
L	⌋	L	R ₁	R ₂	...	R _{N-2}	R _{N-1}	R _{N-1}														
X	⌋	R ₁	R ₂	R ₃	...	R _{N-1}	R _N	R _N														
		X	X	X	...	X	X	X	L	R ₁	R ₂	R ₃	...	R _{N-1}	R _N							
		P ₁	P ₂	P ₃	...	P _{N-1}	P _N	P _N	H	P ₁	P ₂	P ₃	...	P _{N-1}	P _N	L						
										X	X	X	...	X	X	H	H	H	...	H	H	

L = Low Logic (Voltage) Level H = High Logic (Voltage) Level X = Irrelevant P = Present State R = Previous State

6277
8-BIT SERIAL-INPUT,
CONSTANT-CURRENT
LATCHED LED DRIVER

ELECTRICAL CHARACTERISTICS at $T_A = +25^\circ\text{C}$, $V_{H/L} = V_{DD} = 5\text{ V}$ (unless otherwise noted).

Characteristic	Symbol	Test Conditions	Limits			
			Min.	Typ.	Max.	Unit
Supply Voltage Range	V_{DD}	Operating	4.5	5.0	5.5	V
Under-Voltage Lockout	$V_{DD(UV)}$	$V_{DD} = 0$ to 5 V	3.4	–	4.0	V
Output Current (any single output)	I_O	$V_{CE} = 1.0\text{ V}$, $R_{EXT} = 160\ \Omega$	100	120	140	mA
		$V_{CE} = 0.4\text{ V}$, $R_{EXT} = 470\ \Omega$	34	42	48	mA
Output Current Matching (difference between any two outputs at same V_{CE})	ΔI_O	0.4 V $\leq V_{CE(A)} = V_{CE(B)} \leq 1.0\text{ V}$: $R_{EXT} = 160\ \Omega$ $R_{EXT} = 470\ \Omega$	–	± 1.5	± 6.0	%
			–	± 1.5	± 6.0	%
Output Leakage Current	I_{CEX}	$V_{OH} = 20\text{ V}$	–	1.0	5.0	μA
Logic Input Voltage	V_{IH}		$0.7V_{DD}$	–	–	V
	V_{IL}		–	–	$0.3V_{DD}$	V
SERIAL DATA OUT Voltage (SDO_1 & SDO_2)	V_{OL}	$I_{OL} = 1.0\text{ mA}$	–	–	0.4	V
	V_{OH}	$I_{OH} = -1.0\text{ mA}$	4.6	–	–	V
Input Resistance	R_I	ENABLE input, pull up	150	300	600	k Ω
		LATCH & HIGH/LOW inputs, pull down	100	270	400	k Ω
Supply Current	$I_{DD(OFF)}$	$R_{EXT} = \text{open}$, $V_{OE} = 5\text{ V}$	–	0.8	1.6	mA
		$R_{EXT} = 470\ \Omega$, $V_{OE} = 5\text{ V}$	3.5	6.5	9.5	mA
		$R_{EXT} = 160\ \Omega$, $V_{OE} = 5\text{ V}$	14	17	22	mA
	$I_{DD(ON)}$	$R_{EXT} = 470\ \Omega$, $V_{OE} = 0\text{ V}$	5.0	10	15	mA
		$R_{EXT} = 160\ \Omega$, $V_{OE} = 0\text{ V}$	20	27	40	mA

Typical Data is at $V_{DD} = 5\text{ V}$ and is for design information only.

6277
8-BIT SERIAL-INPUT,
CONSTANT-CURRENT
LATCHED LED DRIVER

SWITCHING CHARACTERISTICS at $T_A = 25^\circ\text{C}$, $V_{DD} = V_{IH} = 5\text{ V}$, $V_{CE} = 0.4\text{ V}$, $V_{IL} = 0\text{ V}$, $R_{EXT} = 470\ \Omega$, $I_O = 40\text{ mA}$, $V_L = 3\text{ V}$, $R_L = 65\ \Omega$, $C_L = 10.5\text{ pF}$.

Characteristic	Symbol	Test Conditions	Limits			
			Min.	Typ.	Max.	Unit
Propagation Delay Time	t_{pHL}	CLOCK-OUT _n	–	350	1000	ns
		LATCH-OUT _n	–	350	1000	ns
		ENABLE-OUT _n	–	350	1000	ns
		CLOCK-SERIAL DATA OUT ₁	–	80	110	ns
Propagation Delay Time	t_{pLH}	CLOCK-OUT _n	–	300	1000	ns
		LATCH-OUT _n	–	400	1000	ns
		ENABLE-OUT _n	–	380	1000	ns
		CLOCK-SERIAL DATA OUT ₂	–	80	110	ns
Output Fall Time	t_f	90% to 10% voltage	150	250	1000	ns
Output Rise Time	t_r	10% to 90% voltage	150	250	600	ns

RECOMMENDED OPERATING CONDITIONS

Characteristic	Symbol	Conditions	Min.	Typ.	Max.	Unit
Supply Voltage	V_{DD}		4.5	5.0	5.5	V
Output Voltage	V_O		–	1.0	4.0	V
Output Current	I_O	Continuous, any one output	–	–	150	mA
	I_{OH}	SERIAL DATA OUT	–	–	-1.0	mA
	I_{OL}	SERIAL DATA OUT	–	–	1.0	mA
Logic Input Voltage	V_{IH}		$0.7V_{DD}$	–	–	V
	V_{IL}		–	–	$0.3V_{DD}$	V
Clock Frequency	f_{CK}	Cascade operation	–	–	10	MHz

6277 8-BIT SERIAL-INPUT, CONSTANT-CURRENT LATCHED LED DRIVER

TIMING REQUIREMENTS and SPECIFICATIONS

(Logic Levels are V_{DD} and Ground)

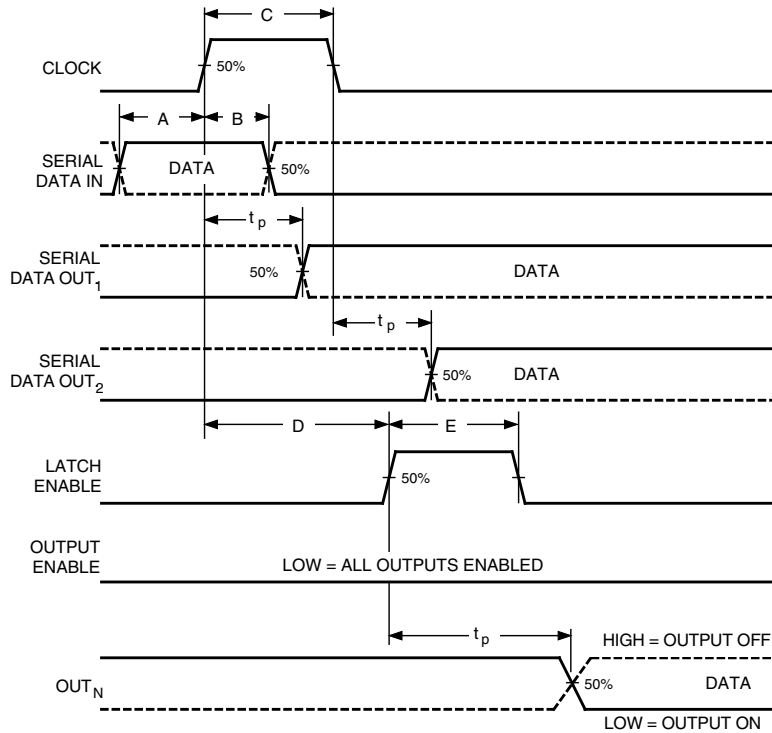

Dwg. WP-029-3

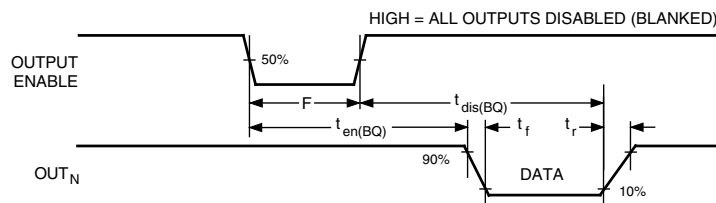

Dwg. WP-030-1

- A.** Data Active Time Before Clock Pulse
(Data Set-Up Time), $t_{su(D)}$ **60 ns**
 - B.** Data Active Time After Clock Pulse
(Data Hold Time), $t_{h(D)}$ **20 ns**
 - C.** Clock Pulse Width, $t_{w(CK)}$ **50 ns**
 - D.** Time Between Clock Activation
and Latch Enable, $t_{su(L)}$ **100 ns**
 - E.** Latch Enable Pulse Width, $t_{w(L)}$ **100 ns**
 - F.** Output Enable Pulse Width, $t_{w(OE)}$ **4.5 μ s**
- NOTE – Timing is representative of a 10 MHz clock.
Significantly higher speeds are attainable.
- Max. Clock Transition Time, t_r or t_f **10 μ s**

Information present at any register is transferred to the respective latch when the LATCH ENABLE is high (serial-to-parallel conversion). The latches will continue to accept new data as long as the LATCH ENABLE is held high. Applications where the latches are bypassed (LATCH ENABLE tied high) will require that the OUTPUT ENABLE input be high during serial data entry.

When the OUTPUT ENABLE input is high, the output source drivers are disabled (OFF). The information stored in the latches is not affected by the OUTPUT ENABLE input. With the OUTPUT ENABLE input low, the outputs are controlled by the state of their respective latches.

6277

8-BIT SERIAL-INPUT, CONSTANT-CURRENT LATCHED LED DRIVER

ALLOWABLE OUTPUT CURRENT AS A FUNCTION OF DUTY CYCLE

A6277xA

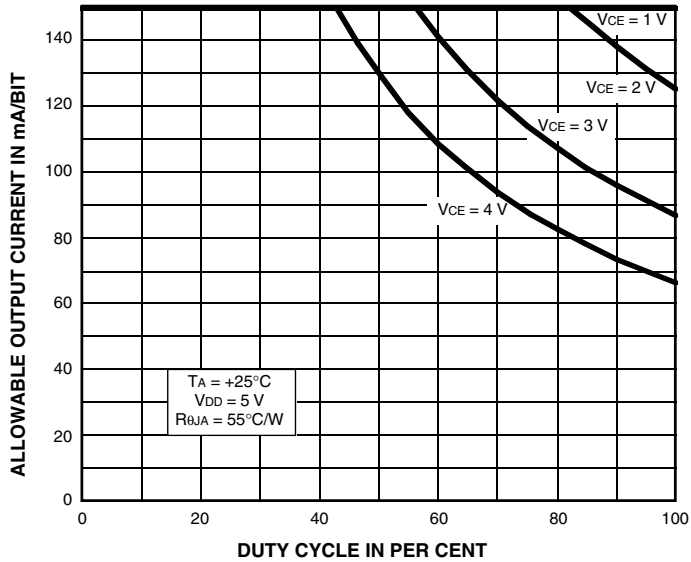

Dwg. GP-062-17

A6277xLW

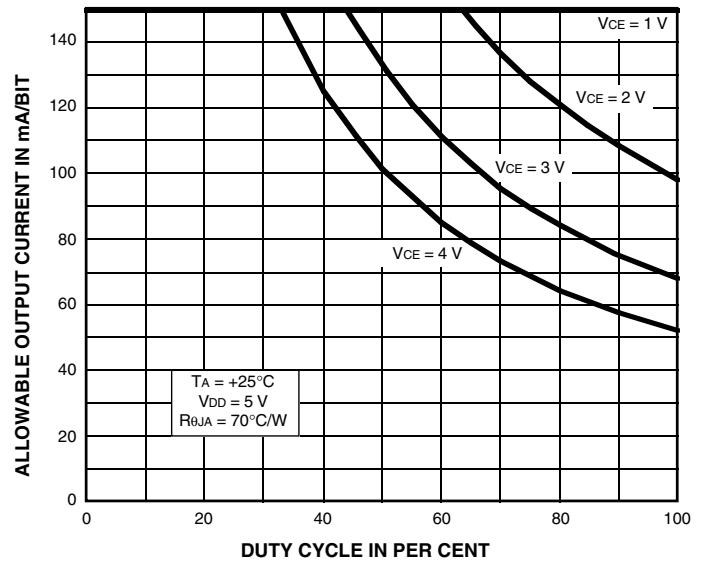

Dwg. GP-062-16

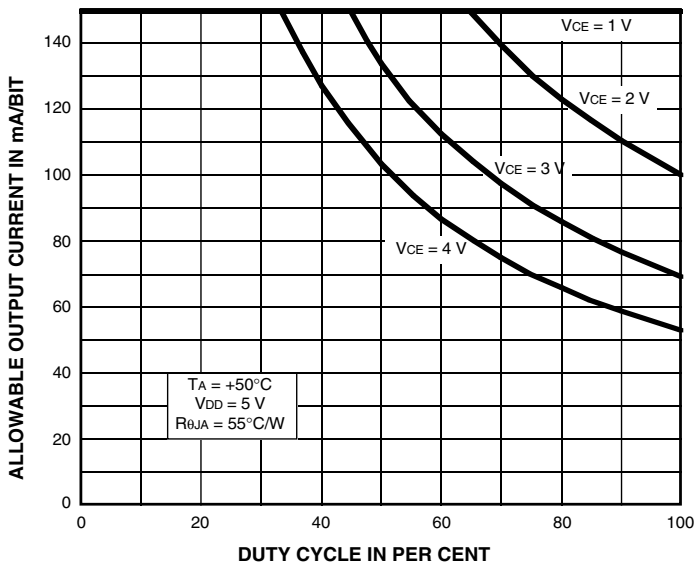

Dwg. GP-062-15

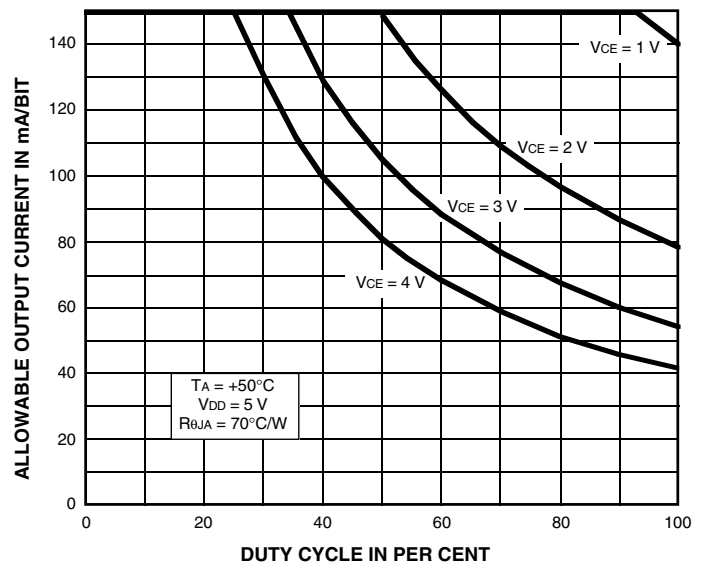

Dwg. GP-062-14

6277

8-BIT SERIAL-INPUT, CONSTANT-CURRENT LATCHED LED DRIVER

ALLOWABLE OUTPUT CURRENT AS A FUNCTION OF DUTY CYCLE (cont.)

A6277xA

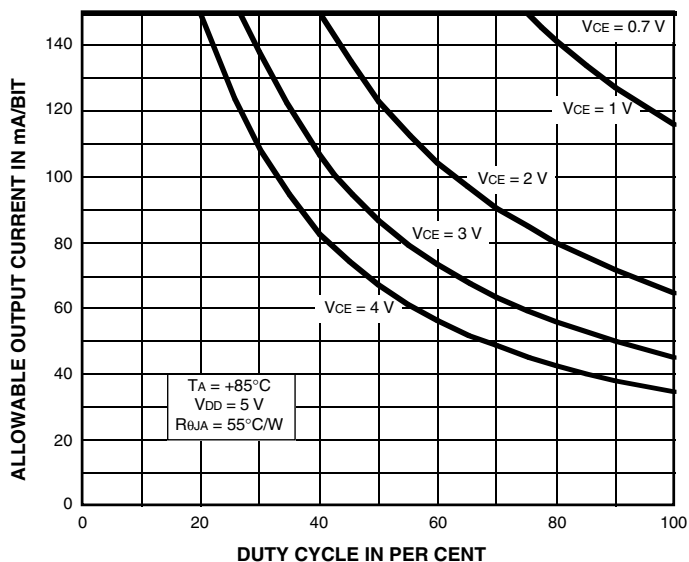

Dwg. GP-062-13

A6277xLW

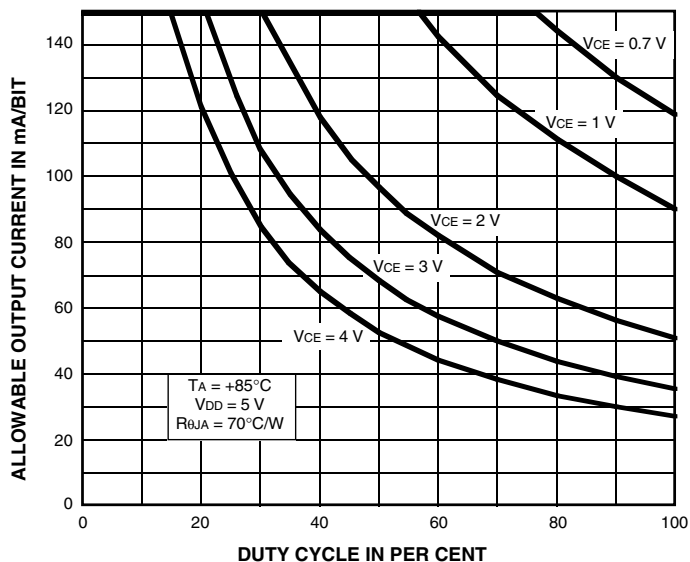

Dwg. GP-062-12

TYPICAL CHARACTERISTICS

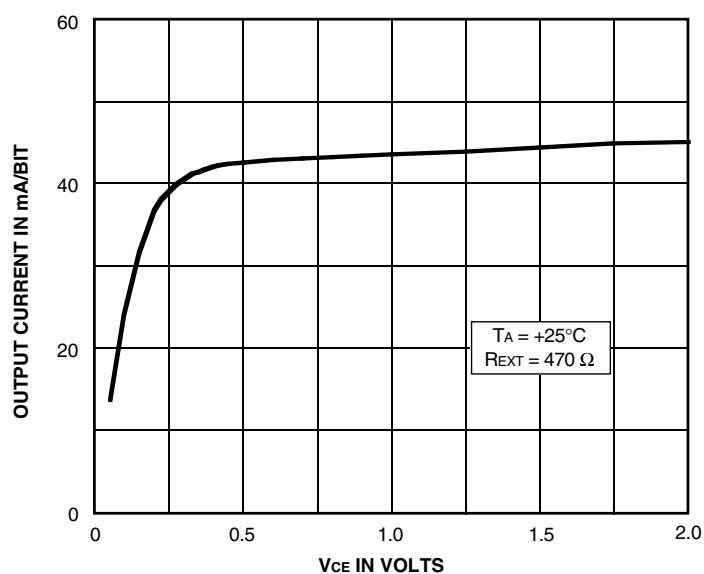

Dwg. GP-063-1

6277
8-BIT SERIAL-INPUT,
CONSTANT-CURRENT
LATCHED LED DRIVER

TERMINAL DESCRIPTION

Terminal No.	Terminal Name	Function
1	LOGIC GROUND	Reference terminal for control logic.
2	SERIAL DATA IN	Serial-data input to the shift-register.
3	CLOCK	Clock input terminal for data shift on rising edge.
4	LATCH ENABLE	Data strobe input terminal; serial data is latched with high-level input.
5	HIGH/LOW (CURRENT)	Logic low for 100% of programmed current level; logic high for 50% of programmed current level.
6	POWER GROUND	Ground.
7-14	OUT ₀₋₇	The eight current-sinking output terminals.
15	POWER GROUND	Ground.
16	OUTPUT ENABLE	When (active) low, the output drivers are enabled; when high, all output drivers are turned OFF (blanked).
17	SERIAL OUT ₂	CMOS serial-data output (on clock falling edge).
18	SERIAL OUT ₁	CMOS serial-data output (on clock rising edge) to the following shift-registers.
19	R _{EXT}	An external resistor at this terminal establishes the output current for all sink drivers.
20	LOGIC SUPPLY	(V _{DD}) The logic supply voltage. Typically 5 V.

The products described here are manufactured under one or more U.S. patents or U.S. patents pending.

Allegro MicroSystems, Inc. reserves the right to make, from time to time, such departures from the detail specifications as may be required to permit improvements in the performance, reliability, or manufacturability of its products. Before placing an order, the user is cautioned to verify that the information being relied upon is current.

Allegro products are not authorized for use as critical components in life-support devices or systems without express written approval.

The information included herein is believed to be accurate and reliable. However, Allegro MicroSystems, Inc. assumes no responsibility for its use; nor for any infringement of patents or other rights of third parties which may result from its use.

6277

8-BIT SERIAL-INPUT, CONSTANT-CURRENT LATCHED LED DRIVER

Applications Information

The load current per bit (I_O) is set by the external resistor (R_{EXT}) as shown in the figure below.

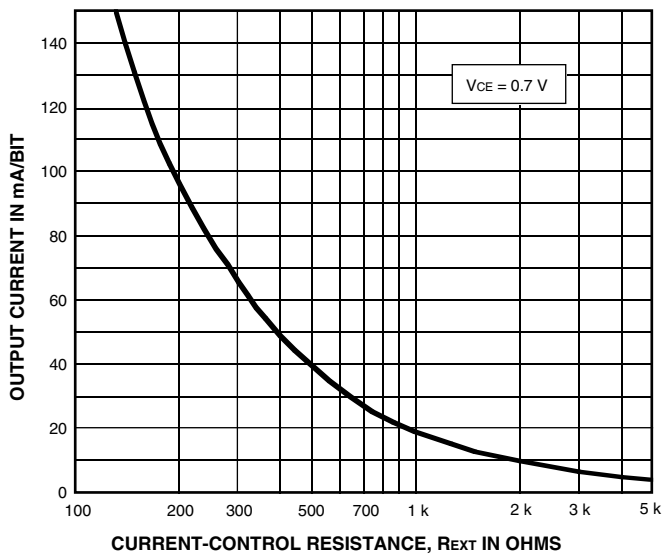

Dwg. GP-061-1

Package Power Dissipation (P_D). The maximum allowable package power dissipation is determined as

$$P_D(\text{max}) = (150 - T_A) / R_{\theta JA}$$

The actual package power dissipation is

$$P_D(\text{act}) = dc(V_{CE} \cdot I_O \cdot 8) + (V_{DD} \cdot I_{DD})$$

When the load supply voltage is greater than 3 V to 5 V, considering the package power dissipating limits of these devices, or if $P_D(\text{act}) > P_D(\text{max})$, an external voltage reducer (V_{DROP}) should be used.

Load Supply Voltage (V_{LED}). These devices are designed to operate with driver voltage drops (V_{CE}) of 0.4 V to 0.7 V with LED forward voltages (V_F) of 1.2 V to 4.0 V. If higher voltages are dropped across the driver, package power dissipation will be increased significantly. To minimize package power dissipation, it is recommended to use the lowest possible load supply voltage or to set any series dropping voltage (V_{DROP}) as

$$V_{DROP} = V_{LED} - V_F - V_{CE}$$

with $V_{DROP} = I_O \cdot R_{DROP}$ for a single driver, or a Zener diode (V_Z), or a series string of diodes (approximately

0.7 V per diode) for a group of drivers. If the available voltage source will cause unacceptable dissipation and series resistors or diode(s) are undesirable, a regulator such as the Sanken Series SAI or Series SI can be used to provide supply voltages as low as 3.3 V.

For reference, typical LED forward voltages are:

Blue	3.0 – 4.0 V
Green	1.8 – 2.2 V
Yellow	2.0 – 2.1 V
Amber	1.9 – 2.65 V
Red	1.6 – 2.25 V
Infrared	1.2 – 1.5 V

Pattern Layout. This device has separate logic-ground and power-ground terminals. If ground pattern layout contains large common-mode resistance, and the voltage between the system ground and the LATCH ENABLE or CLOCK terminals exceeds 2.5 V (because of switching noise), these devices may not operate correctly.

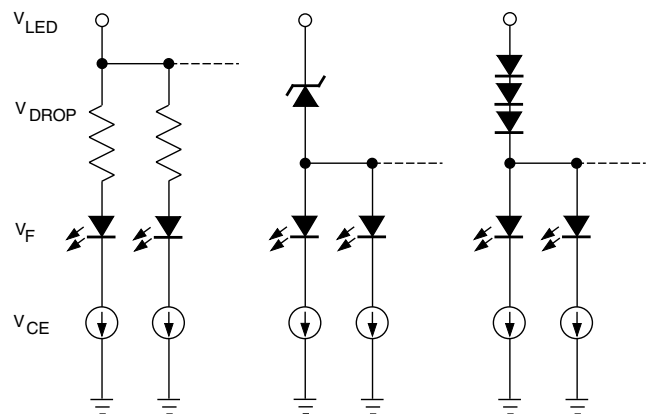

Dwg. EP-064

6277

8-BIT SERIAL-INPUT, CONSTANT-CURRENT LATCHED LED DRIVER

A6277EA

Dimensions in Inches
(controlling dimensions)

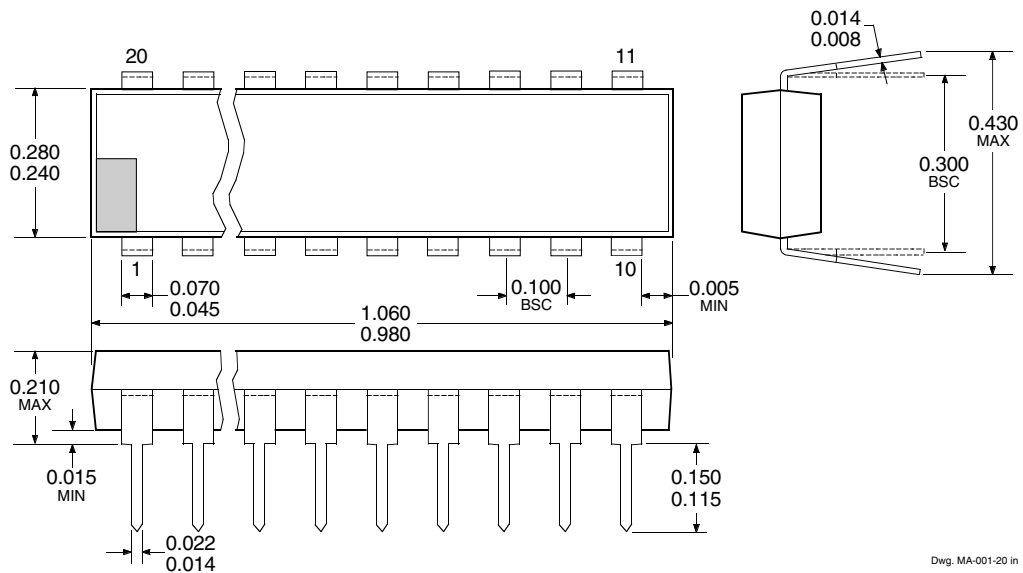

Dimensions in Millimeters (for reference only)

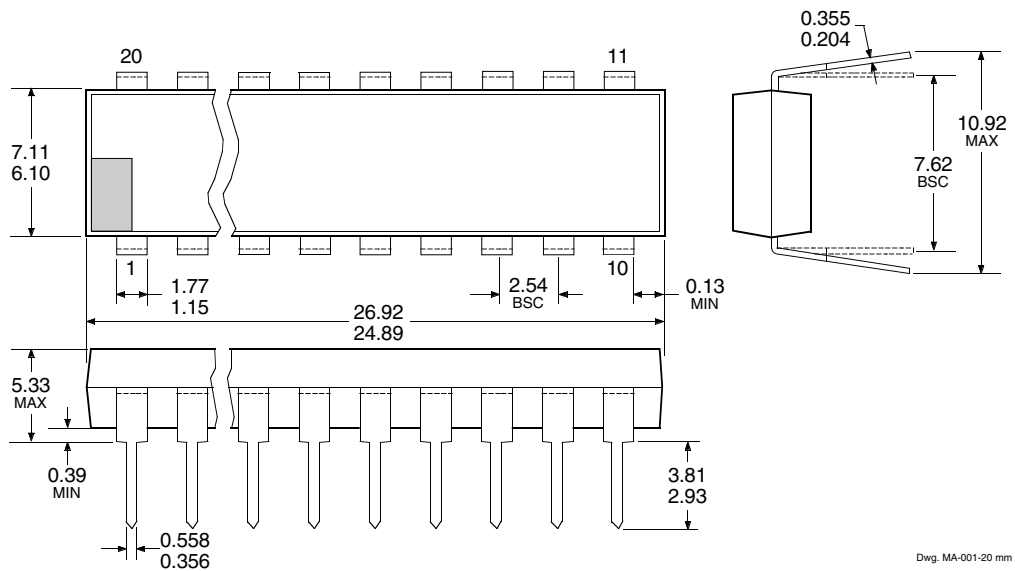

- NOTES: 1. Exact body and lead configuration at vendor's option within limits shown.
 2. Lead spacing tolerance is non-cumulative
 3. Lead thickness is measured at seating plane or below.

6277
8-BIT SERIAL-INPUT,
CONSTANT-CURRENT
LATCHED LED DRIVER

A6277ELW
 Dimensions in Inches
 (for reference only)

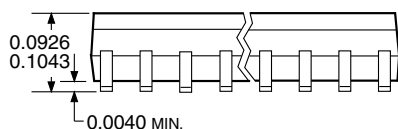
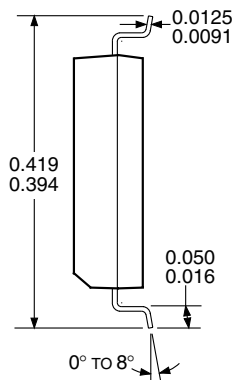
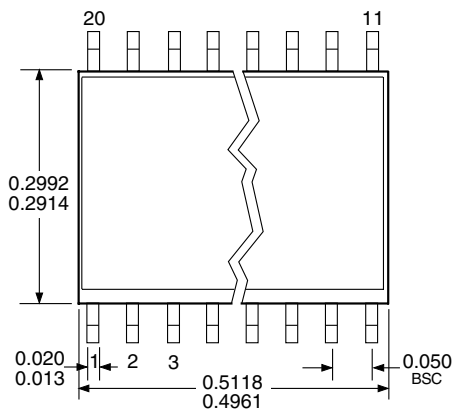

Dwg. MA-008-20 in

Dimensions in Millimeters
 (controlling dimensions)

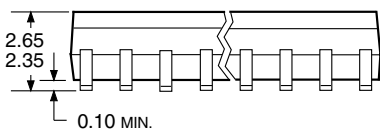
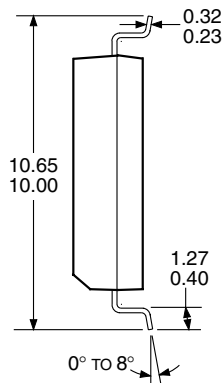
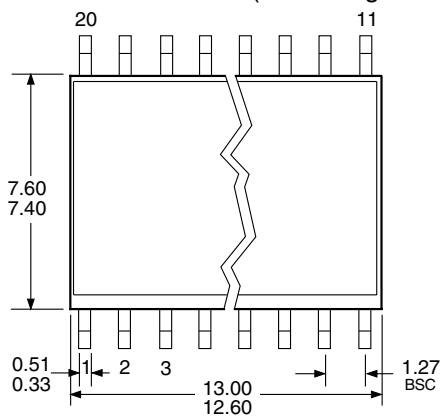

Dwg. MA-008-20 mm

- NOTES: 1. Exact body and lead configuration at vendor's option within limits shown.
 2. Lead spacing tolerance is non-cumulative.