

STR-G6651

Data Sheet
28102.9A

OFF-LINE QUASI-RESONANT FLYBACK SWITCHING REGULATOR

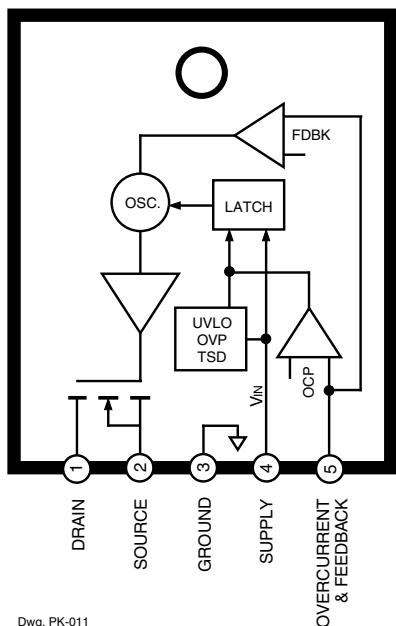

Dwg. PK-011

ABSOLUTE MAXIMUM RATINGS at $T_A = +25^\circ\text{C}$

Control Supply Voltage, V_{IN}	35 V
Drain-Source Voltage, V_{DS}	650 V
Drain Current, I_D	
continuous	2.7 A
single-pulse, $t_w \leq 1$ ms	7.2 A
Avalanche Energy, E_{AS}	
single-pulse	158 mJ
Over-Current Protection Voltage Range,	
V_{OCP}	-0.3 V to +6 V
Insulation RMS Voltage,	
$V_{WM(RMS)}$	2000 V
Package Power Dissipation, P_D	
control ($V_{IN} \times I_{IN(ON)}$)	0.8 W
total	See Graph
FET Channel Temperature, T_J	+150°C
Internal Frame Temperature, T_F	+125°C
Operating Temperature Range,	
T_A	-20°C to +125°C
Storage Temperature Range,	
T_S	-40°C to +125°C

The STR-G6651 is specifically designed to satisfy the requirements for increased integration and reliability in off-line quasi-resonant flyback converters. This device incorporates the primary control and drive circuit with a discrete avalanche-rated power MOSFET.

Cycle-by-cycle current limiting, under-voltage lockout with hysteresis, over-voltage protection, and thermal shutdown protects the power supply during the normal overload and fault conditions. Over-voltage protection and thermal shutdown are latched after a short delay. The latch may be reset by cycling the input supply. Low-current startup and a low-power standby mode selected from the secondary circuit completes a comprehensive suite of features. The device is provided in a five-pin over-molded TO-220 style package, affording dielectric isolation without compromising thermal characteristics. Two lead forms are available (with and without the suffix '-LF') to accommodate printed wiring board layout or mechanical constraints.

Proven in substantial volumes, the STR-G6651 is a robust low-risk solution for off-line power supplies particularly where management of EMI at the source is a significant element of the system design.

FEATURES

- Quasi-Resonant Operation
- Output Power to 66 W
- Low-Loss, Pulse-Ratio-Control Standby Mode
- Temperature-Compensated Pulse-by-Pulse Over-Current Protection
- Latched Over-Voltage and Thermal Protection
- Under-Voltage Lockout with Hysteresis
- Active Low-Pass Filter for Enhanced Light-Load Stability
- Switched Attenuation of Leading-Edge Current-Sensing Signal
- Regulated Soft Gate Drive
- Adjustable Switching Speed for EMI Control
- Overmolded Five-Pin Package

Always order by complete part number: **STR-G6651**.

STR-G6651 OFF-LINE QUASI-RESONANT FLYBACK SWITCHING REGULATOR

FUNCTIONAL BLOCK DIAGRAM

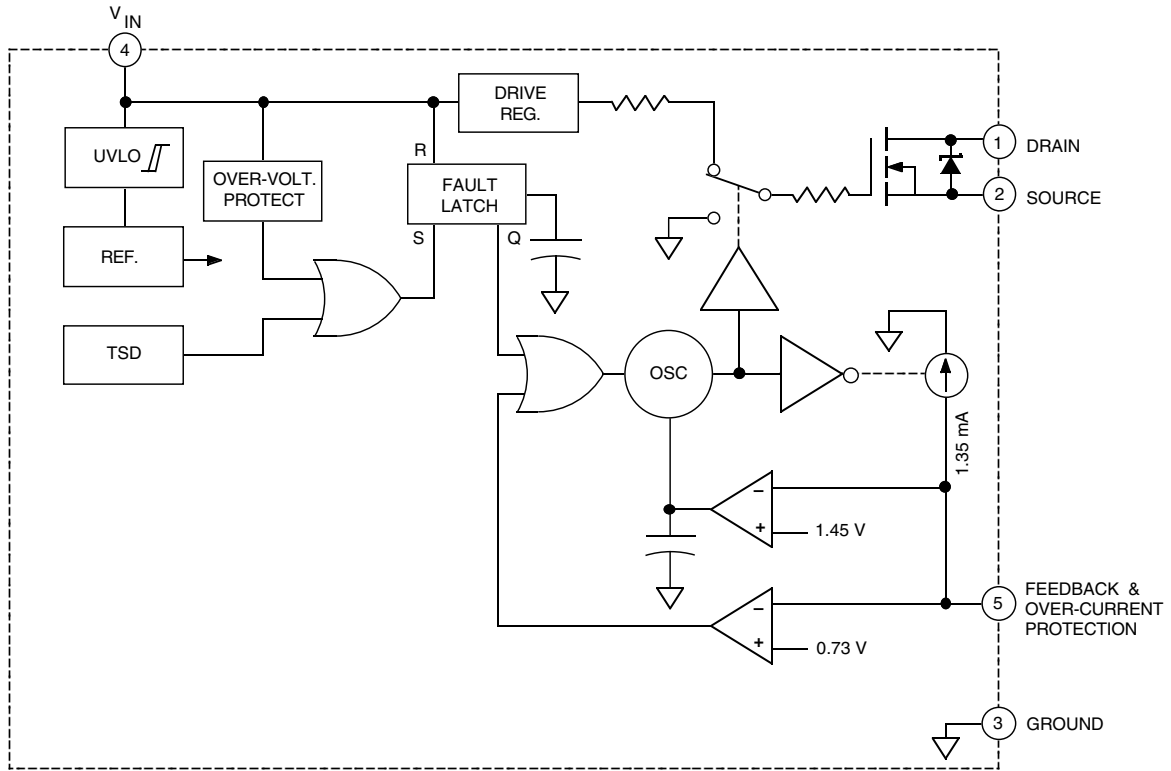

Dwg. FK-002-5

ALLOWABLE PACKAGE POWER DISSIPATION

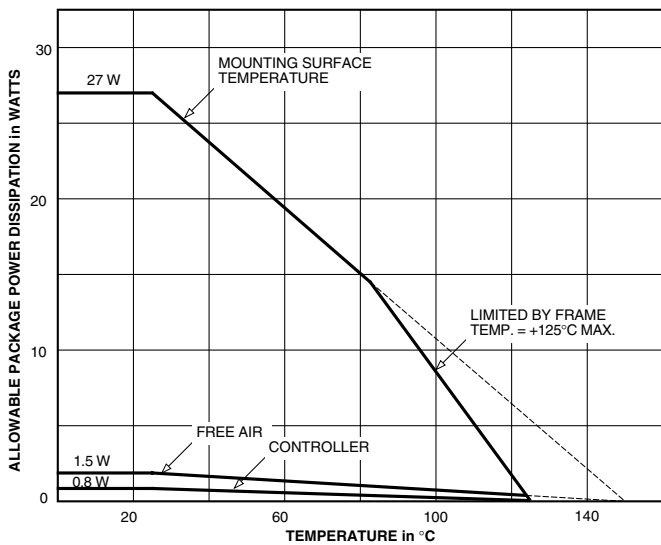

Dwg. GK-003-4

MAXIMUM SAFE OPERATING AREA

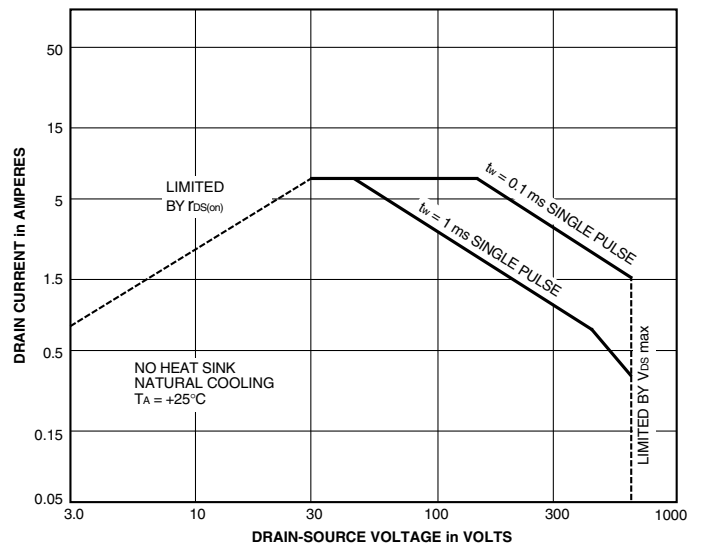

Dwg. GK-004-5



115 Northeast Cutoff, Box 15036
Worcester, Massachusetts 01615-0036 (508) 853-5000
Copyright © 1999, 2000 Allegro MicroSystems, Inc.



STR-G6651
OFF-LINE
QUASI-RESONANT FLYBACK
SWITCHING REGULATOR

ELECTRICAL CHARACTERISTICS at $T_A = +25^\circ\text{C}$, $V_{IN} = 18\text{ V}$, $V_{DD} = 10\text{ V}$, $V_S = 0$, voltage measurements are referenced to ground terminal (unless otherwise specified).

Characteristic	Symbol	Test Conditions	Limits			
			Min.	Typ.	Max.	Units
On-State Voltage	V_{INT}	Turn-on, increasing V_{IN}	14.4	16	17.6	V
Under-Voltage Lockout	V_{INQ}	Turn-off, decreasing V_{IN}	9.0	10	11	V
Over-Voltage Threshold	$V_{OVP(th)}$	Turn-off, increasing V_{IN}	20.5	22.5	24.5	V
Drain-Source Breakdown Voltage	$V_{(BR)DSS}$	$I_D = 300\ \mu\text{A}$	650	–	–	V
Drain Leakage Current	I_{DSS}	$V_{DS} = 650\text{ V}$	–	–	300	μA
On-State Resistance	$r_{DS(on)}$	$V_S = 10\text{ V}$, $I_D = 0.9\text{ A}$, $T_J = +25^\circ\text{C}$	–	–	3.95	Ω
Maximum OFF Time	t_{off}	Drain waveform high	45	–	55	μs
Minimum Pulse Duration for Input of Quasi-Resonant Signals	$t_{w(th)}$	Drain waveform high ¹	–	–	1.0	μs
Minimum OFF Time	t_{off}	Drain waveform high ¹	–	–	1.5	μs
Feedback Threshold Voltage	V_{FDBK}	Drain waveform low to high ¹	0.68	0.73	0.78	V
		Oscillation synchronized ²	1.3	1.45	1.6	V
Over-Current Protection/Feedback Sink Current	$I_{OCP/FB}$	$V_{OCP/FB} = 1.0\text{ V}$	1.2	1.35	1.5	mA
Latch Holding Current	$I_{IN(OVP)}$	V_{IN} reduced from 24.5 V to 8.5 V	–	–	400	mA
Latch Release Voltage	V_{IN}	$I_{IN} \leq 20\ \mu\text{A}$, V_{IN} reduced from 24.5 V	6.6	–	8.4	V
Switching Time	t_f	$V_{DD} = 200\text{ V}$, $I_D = 0.9\text{ A}$	–	–	250	ns
Supply Current	$I_{IN(ON)}$	Operating ³	–	–	30	mA
	$I_{IN(OFF)}$	Increasing V_{IN} prior to oscillation	–	–	100	μA
Insulation RMS Voltage	$V_{WM(RMS)}$	All terminals simultaneous reference metal plate against backside	2000	–	–	V
Thermal Shutdown	T_J		140	–	–	$^\circ\text{C}$
Thermal Resistance	$R_{\theta JM}$	Output junction-to-mounting frame	–	–	1.63	$^\circ\text{C/W}$

Notes: Typical Data is for design information only.

1. Feedback is square wave, $V_{IM} = 2.2\text{ V}$, $t_h = 1\ \mu\text{s}$, $t_l = 35\ \mu\text{s}$
2. For quasi-resonant operation, the input signal must be longer than $t_{w(th)}$ and greater than V_{FDBK}
3. Feedback is square wave, $V_{IM} = 2.2\text{ V}$, $t_h = 4\ \mu\text{s}$, $t_l = 1\ \mu\text{s}$

STR-G6651
OFF-LINE
QUASI-RESONANT FLYBACK
SWITCHING REGULATOR

ALLOWABLE AVALANCHE ENERGY

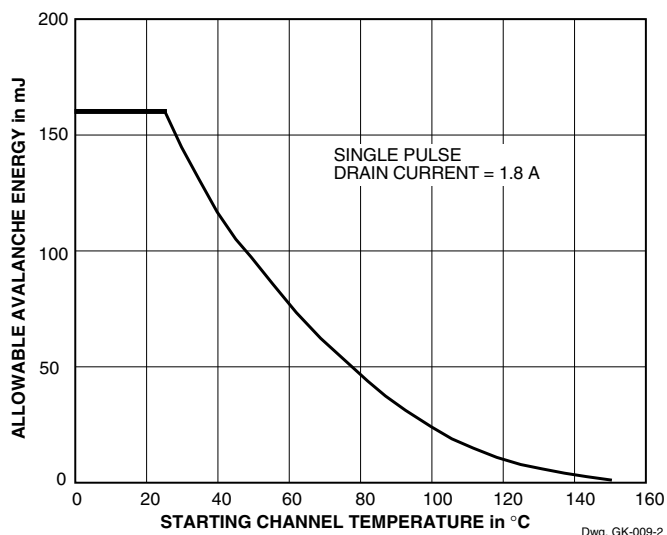

STR-G6600 Series

Part Number	Drain-Source Output Breakdown Voltage at $I_D = 300 \mu A$ $V_{(BR)DS}$, Minimum	Drain-Source ON Resistance at $I_D = 0.9 A$ $r_{DS(on)}$, Maximum	Output Power
For 100/120 V AC Input			
STR-G6622	450 V	2.18 Ω	44 W – 60 W
STR-G6624	450 V	0.92 Ω	98 W – 130 W
For 110/120 V AC Input			
STR-G6632	500 V	2.62 Ω	36 W – 50 W
For 200/220 V AC Input			
STR-G6651	650 V	3.95 Ω	66 W
STR-G6652	650 V	2.80 Ω	86 W
STR-G6653	650 V	1.95 Ω	120 W

STR-G6651 OFF-LINE QUASI-RESONANT FLYBACK SWITCHING REGULATOR

TYPICAL QUASI-RESONANT FLYBACK CONVERSION USING STR-G6651

WARNING: lethal potentials are present. See text.

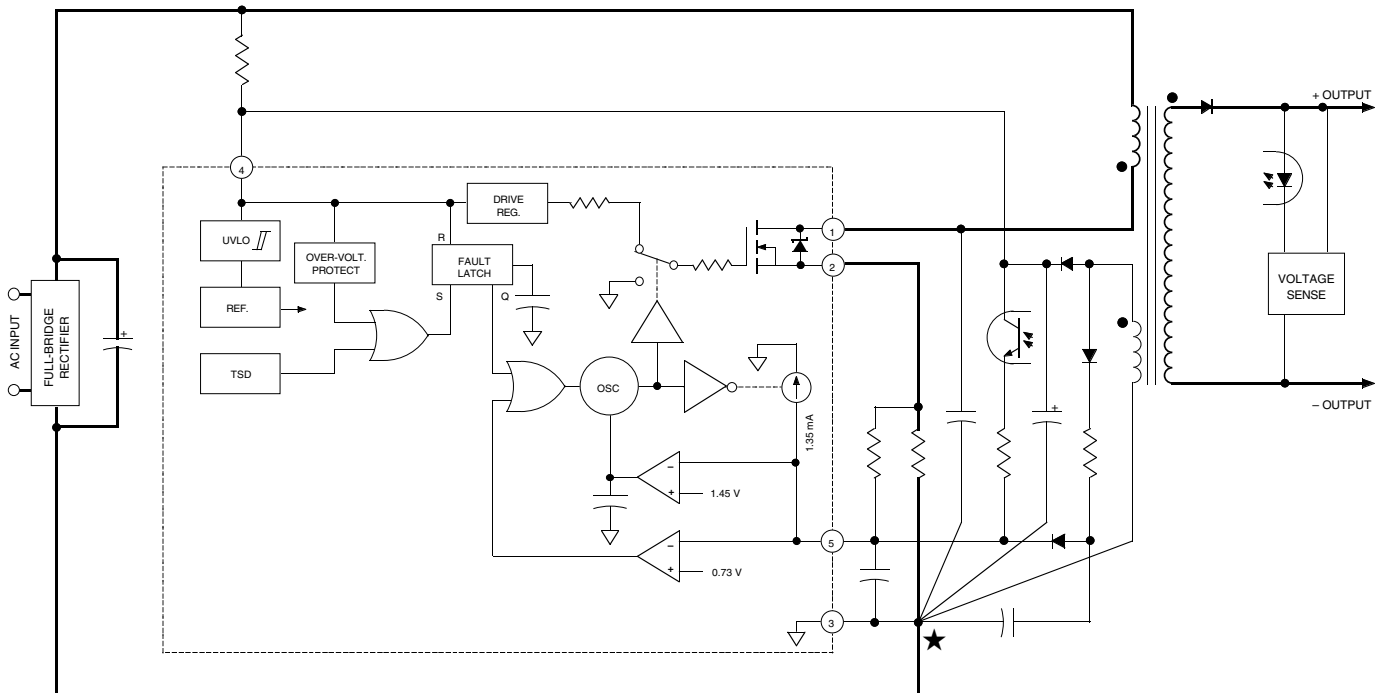

Dwg. EK-003-4A

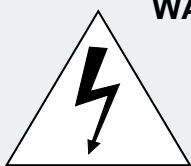

WARNING — These devices are designed to be operated at lethal voltages and energy levels. Circuit designs that embody these components must conform with applicable safety requirements. Precautions must be taken to prevent accidental contact with power-line potentials. Do not connect grounded test equipment.

The use of an isolation transformer is recommended during circuit development and breadboarding.

Recommended mounting hardware torque:

4.34 - 5.79 lbf•ft (6 - 8 kg•cm or 0.588 - 0.784 Nm).

Recommended silicone grease:

Dow Corning SC102, Toshiba YG6260, Shin-Etsu G746., or equivalent

STR-G6651
OFF-LINE
QUASI-RESONANT FLYBACK
SWITCHING REGULATOR

STR-G6651
(LF1129)

Dimensions in Inches
(for reference only)

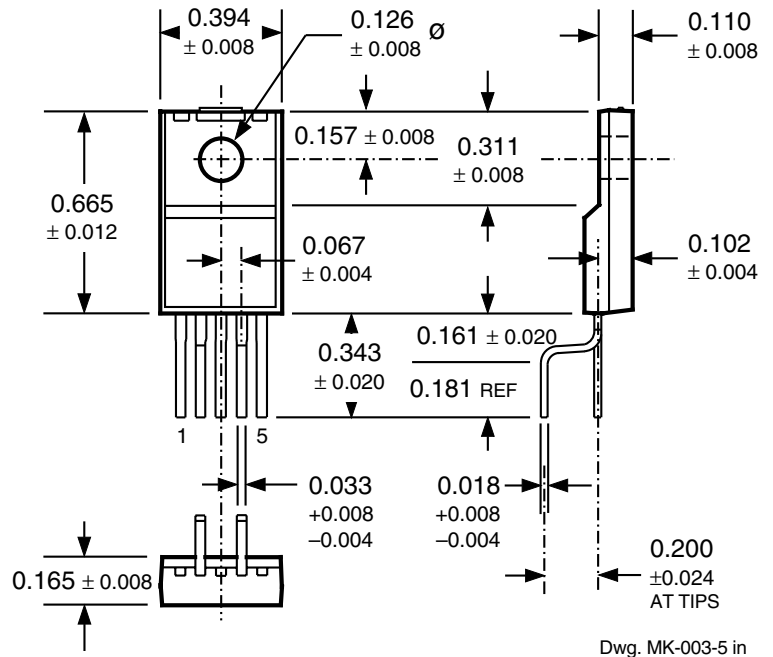

Dimensions in Millimeters
(controlling dimensions)

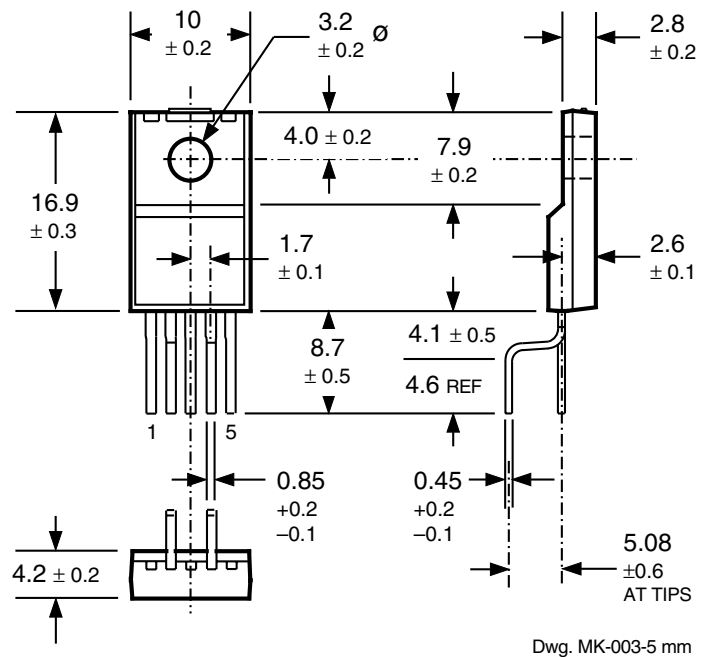

STR-G6651
OFF-LINE
QUASI-RESONANT FLYBACK
SWITCHING REGULATOR

STR-G6651-LF
(LF1128)

Dimensions in Inches
(for reference only)

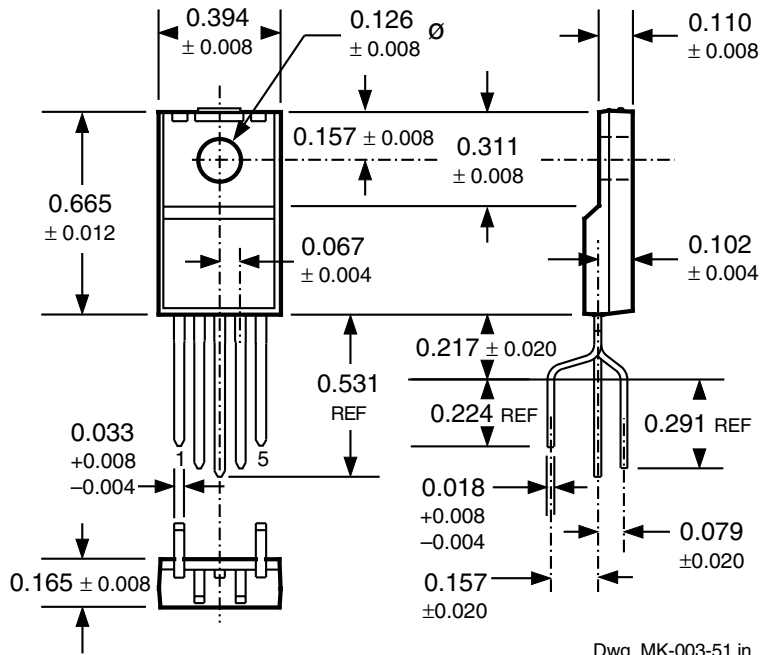

Dimensions in Millimeters
(controlling dimensions)

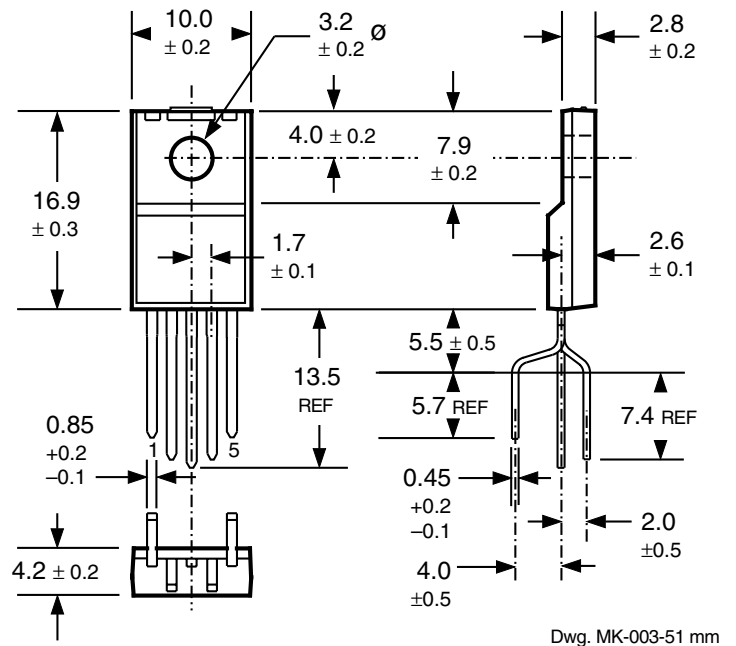

STR-G6651
OFF-LINE
QUASI-RESONANT FLYBACK
SWITCHING REGULATOR

The products described here are manufactured in Japan by Sanken Electric Co., Ltd. for sale by Allegro MicroSystems, Inc.

Sanken Electric Co., Ltd. and Allegro MicroSystems, Inc. reserve the right to make, from time to time, such departures from the detail specifications as may be required to permit improvements in the performance, reliability, or manufacturability of their products. Therefore, the user is cautioned to verify that the information in this publication is current before placing any order.

These products are not authorized for use as critical components in life-support appliances, devices, or systems without express written approval.

The information included herein is believed to be accurate and reliable. However, Sanken Electric Co., Ltd. and Allegro MicroSystems, Inc. assume no responsibility for its use; nor for any infringements of patents or other rights of third parties which may result from its use.



115 Northeast Cutoff, Box 15036
Worcester, Massachusetts 01615-0036 (508) 853-5000

