



Austria Mikro Systeme International AG

Key Features

- ❑ Line/speech handsfree circuit, LD/MF repertory dialler, and tone ringer on one 44 pin CMOS chip
- ❑ Operating range from 15 to 100 mA line current (down to 5 mA with slightly reduced performance)
- ❑ All significant parameters programmable with external EEPROM
- ❑ Volume control of receiver signal
- ❑ Handsfree function with enhanced voice switching
- ❑ Low noise (max. -72 dBmp)
- ❑ Unique EMC performance
- ❑ LD/MF switchable dialling with temporary MF mode
- ❑ Repertory dialling with last number redial and memory dialling (8 x 2 direct and 10 indirect)
- ❑ Call restriction with PIN code
- ❑ Serial interface for EEPROM and LCD driver
- ❑ 2-tone/3-tone ringer with ring frequency detection

Block Diagramme

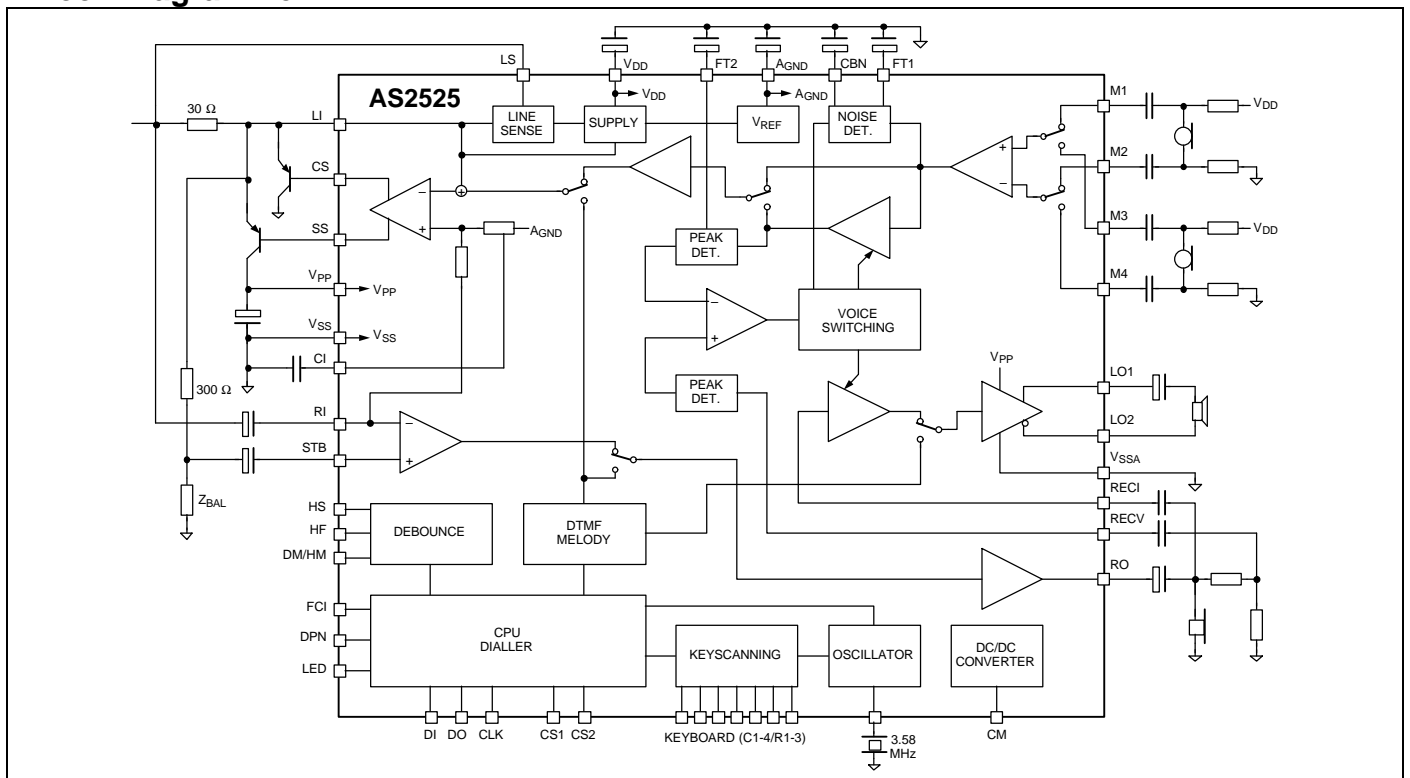

Single-Chip Handsfree Phone CMOS Integrated Circuit

General Description

The AS2525 is a CMOS mixed-mode integrated circuit for use in feature phones, answering machines and fax machines. It contains an analogue line interface and speech circuit for a/b terminals, loudhearing, handsfree, enhanced LD/MF dialler, tone ringer with dc/dc converter and serial interface to EEPROM and LCD-driver (AS2591), all in a 44 pin package. The circuit is fully line powered.

The AS2525 uses an external EEPROM for a 31 digit last number redial storage and memories for 26 numbers each containing up to 21 digits/data.

The device provides a volume control for the earpiece and the loudspeaker. The volume can be controlled by pressing the [V-]/[V+] keys.

The versatility of the circuit is provided by programming all parameters through an external EEPROM. This allows easy adaptation to various PTT requirements worldwide.

Package

Available in 44 pin TQFP.

Pin Description

| Pin # | Symbol | Type | Description |
|-------|-----------------|--------|---|
| 1 | CS2 | DO | Chip Select 2 Chip select signal for external LCD driver circuit or 2 mA LED If signal is not activated, a pull down resistor (100 k Ω) is inserted. |
| 2 | DPn | DO | Dial Pulse Output Digital output which holds the line during off-hook operation or pulls low during break periods of pulse dialling and flash. |
| 3 | HF | DI | HandsFree Switch Input This is an Schmitt-trigger input that is pulled high to enable handsfree operation. |
| 4 | HS | DI | HandSet Switch Input This is an Schmitt-trigger input that is pulled high by the hook switch to enable handset or headset operation. |
| 5 | FT1 | AI | Analogue input pin for connecting a capacitor for offset cancellation. |
| 6 | FT2 | AI | Analogue input pin for connecting a capacitor for offset cancellation. |
| 7 | M4 | AI | Microphone Input 4 Differential input for the handsfree microphone (electret). |
| 8 | M2 | AI | Microphone Input 2 Differential input for the handset microphone (electret). |
| 9 | M3 | AI | Microphone Input 3 Differential input for the handsfree microphone (electret). |
| 10 | M1 | AI | Microphone Input 1 Differential input for the handset microphone (electret). |
| 11 | STB | AI | Side Tone Balance Input Analogue input for side tone cancellation network. |
| 12 | CS | AO | Current Shunt Control Output N-channel open drain output to control the external high power shunt transistor for synthesising ac- and dc-impedance, modulation of line voltage and shorting the line during make periods of pulse dialling. |
| 13 | V _{SS} | Supply | Voltage Source Source Negative Power Supply. |
| 14 | LI | AI | Line Input Analogue input used for power extraction and line current sensing. |
| 15 | RI | AI | Receive Input Analogue input for ac-separated receive signal. |
| 16 | SS | AO | Supply Source Control Output N-channel open drain output to control the external high power source transistor for supplying (V _{pp}) the loudspeaker amplifier in off-hook loudspeaking/handsfree mode. |
| 17 | LS | AI | Line Current Sense Input Analogue input for sensing the line current. |

| Pin # | Symbol | Type | Description |
|----------------------|----------------------|--------|--|
| 18 | CI | AI | C omplex I mpedance Input Analogue input pin for the capacitor to program a complex impedance. |
| 19 | RECI | AI | RE Ceive Input Analogue input for the handsfree receive path. Should be connected to RO via a coupling capacitor. |
| 20 | RECV | AI | RE Ceive V oice Switching Input Analogue input for receive voice switching path. |
| 21 | RO | AO | R eceive O utput to H andset Output for driving a dynamic earpiece with an impedance from 150 Ω to 300 Ω . |
| 22 | V _{DD} | Supply | V oltage D rain D rain Positive Power Supply. |
| 23 | A _{GND} | Supply | A nalogue G round Special ground for the internal amplifiers. |
| 24 | CBN | AI | Analogue input pin for connecting a capacitor for background noise monitoring. |
| 25 | CM | DO | C onverter M ake Output This is an output for controlling the external switching converter. During ringing it converts the ring signal into a 4V supply voltage. |
| 26 | V _{PP} | Supply | Loudspeaker Power Supply High power supply for the output driver stage. |
| 27 28 | LO1 LO2 | AO | L oudspeaker O utputs 1/2 Output pins for a 32 Ω (25 to 50 Ω) loudspeaker. |
| 29 | V _{SSA} | Supply | Power supply pin for LO1-LO2 output amplifier. |
| 30 | DM/HM | DI | D ial M ode/ H eadset M ode Switch Input Digital input for choosing between LD and MF dialling or choosing handset and headset mode. See "Table 3: Parameter settings" for further details. This pin is scanned after manual off-hook only. |
| 31 | FCI | DI | F requency C omperator Input This is a Schmitt-trigger input for ring frequency discrimination. Disabled during off-hook. |
| 32 | LED | DO | LED Output Digital output for connecting 2 mA LED to indicate handsfree mode. |
| 33 | OSC | | O scillator Input Input for ceramic resonator 3.58 MHz. |
| 34 35 36 | R1 R2 R3 | DI/O | Keyboard R ows (see Figure 4: Keyboard Layout). |
| 37 38 39 40 | C1 C2 C3 C4 | DI/O | Keyboard C olumns (see Figure 4: Keyboard Layout). |
| 41 | CLK | DO | C lock Clock output for 3-wire bus. If signal is not activated, a pull down resistor (100 k Ω) is inserted. |

| Pin # | Symbol | Type | Description |
|-------|--------|------|---|
| 42 | DI | DI | Data Input Data input of 3-wire bus. If signal is not activated, a pull down resistor (100 kΩ) is inserted. |
| 43 | DO | DO | Data Output Data output of 3-wire bus. A 100 kΩ resistor connected from this pin to VSS enables key locking. If signal is not activated, a pull down resistor (100 kΩ) is inserted. |
| 44 | CS1 | DO | Chip Select 1 Chip select signal for external EEPROM. If signal is not activated, a pull down resistor (100 kΩ) is inserted. |

DI: Digital Input
DO: Digital Output
DI/O: Digital Input/Output

AI: Analogue Input
AO: Analogue Output
AI/O: Analogue Input/output

Pin Configuration

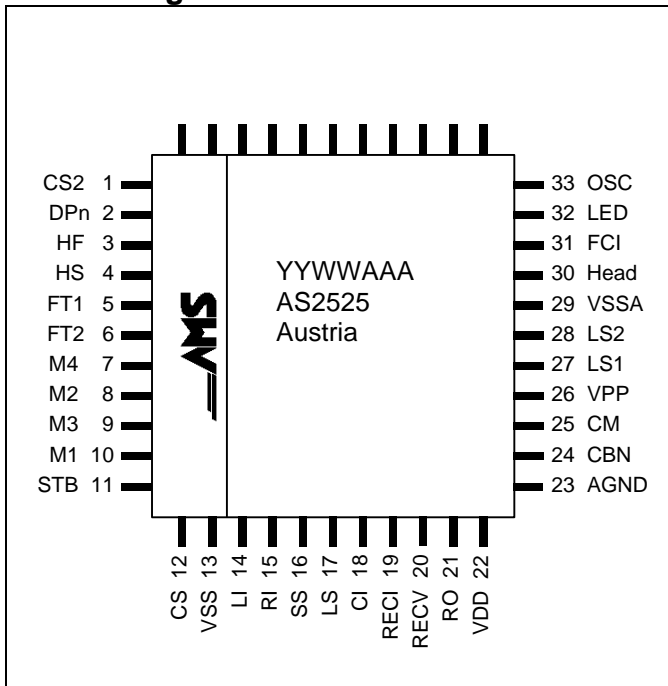

Figure 3: Pin configuration

Keyboard Layout

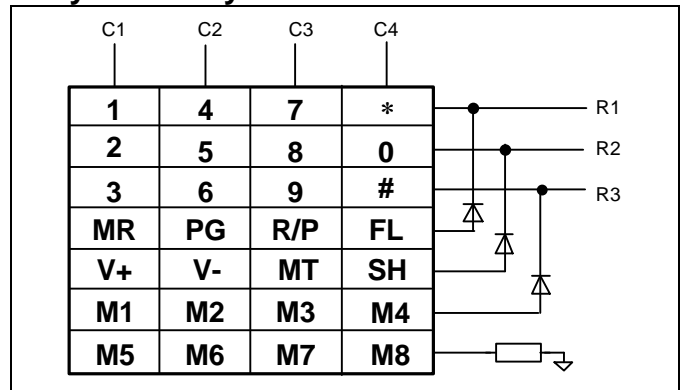

Figure 4: Keyboard Layout

Maximum R_{ON} for key closure: 1 kΩ

Minimum R_{OFF} for open key: 1 MΩ

See "Table 1: Key definitions" for description of key functions.

Basic Definitions

Password is set to 0123 and is used to access basic parameter settings (see Table 3: Parameter settings). The set-up programming is normally done in the factory during manufacturing of the telephone sets. The factory settings can be loaded into the EEPROM (see Figure 6: Memory allocation for external EEPROM).

PIN code is default set to 1111 and is used by the user to protect certain user settings (see Table 5: User programming with PIN code). The PIN code can be changed by the user.

Default settings are shown in **bold**.

Program procedures are entered with the [PG] key. Pressing any invalid key or going on-hook during programming will abort the program mode and no changes will be stored. Ending a program procedure by pressing the [PG] key will store the changes and exit the program mode.

Key Definitions and Procedures

Table 1: Key definitions

| Key | Condition | Function | Remark |
|------------------------|-----------------|-------------------------|---|
| [0] - [9], [#], [*] | Off-hook | Digits | Function depending on mode |
| [*] | LD mode | Temporary MF select | Providing mixed mode dialling (default LD selected) |
| [PG] | Speech mode | Enter programme state | To enter the programme state |
| | Programme mode | Exit programme state | To terminate/exit programme state |
| [MT] | Speech mode | Enter mute state | To enter mute state |
| | Mute state | Exit mute state | To terminate/exit mute state |
| | Programme mode | Enter blank | To enter blank digit during programming |
| [R/P] | | Redial/Pause | Allows re-signalling of the last dialled number and insertion of pauses |
| | Programme state | Pause | Each key pressure inserts a pause |
| [FL] | | Flash function | Invokes a timed loop break |
| [V+] | Speech mode | Volume control | To increase the receive gain |
| [V-] | Speech mode | Volume control | To increase or decrease the receive gain |
| [MR] | | Memory redial key | To access memory by key codes |
| [M1] - [M8] | | Memory dial | Access keys to memories 1 to 8 and 9 to 16 |
| [SH] | | Second function (shift) | To access second function of keys |

Table 2: Digits

| Digit Key | DTMF Mode ($f_{\text{LOW}} + f_{\text{HIGH}}$) | Pulse Mode | Programming Mode ([PG] + Digit) | Memory Location ([MR] + Digit) |
|-----------|---|---------------------|------------------------------------|-----------------------------------|
| [0] | 941 + 1336 Hz | 10 pulses | | Memory 17 |
| [1] | 697 + 1209 Hz | 1 pulse | To enter PIN protected programming | Memory 18 |
| [2] | 697 + 1336 Hz | 2 pulses | Select flash duration | Memory 19 |
| [3] | 697 + 1477 Hz | 3 pulses | Select dialling mode | Memory 20 |
| [4] | 770 + 1209 Hz | 4 pulses | Select pause duration | Memory 21 |
| [5] | 770 + 1336 Hz | 5 pulses | Key lock toggle | Memory 22 |
| [6] | 770 + 1477 Hz | 6 pulses | Ringer volume | Memory 23 |
| [7] | 852 + 1209 Hz | 7 pulses | Ringer melody | Memory 24 |
| [8] | 852 + 1336 Hz | 8 pulses | LCD contrast | Memory 25 |
| [9] | 852 + 1477 Hz | 9 pulses | Ringer on/off | Memory 26 |
| [*] | 941 + 1209 Hz | Temporary MF select | | - |
| [#] | 941 + 1477 Hz | - | | - |

Table 3: Parameter settings

| Parameter | Symbol | Procedure: [PG] + [0] + (Password) + | Default | Options |
|------------------------|-----------------------|---|------------------------------------|--|
| Inter-Digit Pause (LD) | IDP | [*] + [1] + [HEX code] | 840 ms | 1.72 ms ... 7.03 sec. (see Table 4) |
| MF Tone Duration | TD | [*] + [2] + [HEX code] | 82 ms | 1.72 ms ... 7.03 sec. (see Table 4) |
| MF Inter-Tone Pause | ITP | [*] + [3] + [HEX code] | 82 ms | 1.72 ms ... 7.03 sec. (see Table 4) |
| Flash 1 Duration | FL1 | [*] + [4] + [HEX code] | 101 ms | 1.72 ms ... 7.03 sec. (see Table 4) |
| Flash 2 Duration | FL2 | [*] + [5] + [HEX code] | 285 ms | 1.72 ms ... 7.03 sec. (see Table 4) |
| Pause 1 Duration | P1 | [*] + [6] + [HEX code] | 1 second | 1.72 ms ... 7.03 sec. (see Table 4) |
| Pause 2 Duration | P2 | [*] + [7] + [HEX code] | 3 seconds | 1.72 ms ... 7.03 sec. (see Table 4) |
| Pre-Digit Pause (LD) | PDP | [*] + [8] + [HEX code] | 33 ms | 1.72 ms ... 7.03 sec. (see Table 4) |
| Post Flash Pause | PFP | [*] + [9] + [HEX code] | 274 ms | 1.72 ms ... 7.03 sec. (see Table 4) |
| Tx Gain, Handset | A _{TX-HS} | [0] + [1] + [HEX code] | 37 dB | 30 to 45 dB (see Table 8) |
| Rx Gain, Handset | A _{RX-HS} | [0] + [2] + [HEX code] | 1 dB | -6 to 9 dB (see Table 12) |
| Tx Gain, Handsfree | A _{TX-HF} | [0] + [3] + [HEX code] | 46 dB | 39 to 54 dB (see Table 10) |
| Rx Gain, Loudspeaker | A _{RX-HS} | [0] + [4] + [HEX code] | 29 dB | 22 to 37 dB (see Table 14) |
| Line Loss Compensation | LLC | [0] + [5] + | [0] = off | [1] = range 1: I _{LINE} = 20 - 50 mA [2] = range 2: I _{LINE} = 45 - 75 mA |
| DTMF Level (Low Group) | V _{MF} | [0] + [6] + [HEX code] | -6 dBm | -18 to -6 dBm in 1 dB steps (see Table 24) |
| Tx Gain, Headset | A _{TX-HEAD} | [0] + [7] + [HEX code] | 37 dB | 30 to 45 dB (see Table 20) |
| Rx Gain, Headset | A _{RX-HEAD} | [0] + [8] + [HEX code] | 1 dB | -6 to 9 dB (see Table 21) |
| MF Comfort Tone, RO | V _{MF-CT/RO} | [0] + [9] + [HEX code] | -30 dBr | -36 to -18 dBr in 6 dB steps (see Table 30) |
| MF Comfort Tone, LO1/2 | V _{MF-CT/LO} | [0] + [0] + [HEX code] | -9 dBr | -15 to 3 dBr in 6 dB steps (see Table 30) |
| Make/Break Ratio (LD) | M/B | [#] + [1] + | [1] = 2 : 3 | [0] = 1 : 2 |
| Dial Rate (LD) | DR | [#] + [2] + | [0] = 10 pps | [1] = 20 pps |
| DC Mask (LI Voltage) | V _{LI} | [#] + [3] + | [1] = 4.5 Volt | [0] = 3.5 Volt |
| Tx Soft Clip (Handset) | | [#] + [4] + | [1] = on (2 V _{PEAK}) | [0] = off |
| Rx Soft Clip (Handset) | | [#] + [5] + | [1] = on (1 V _{PEAK}) | [0] = off |
| Noise Monitoring (HF) | | [#] + [6] + | [1] = on | [0] = off |
| Loudhearing Mode | | [#] + [7] + | [1] = HF only | [0] = LH and HF modes available |
| Ringer Melody | | [#] + [8] + | [1] = 3-Tone | [0] = 2-Tone |
| Key-in Tone (Beep) | KT | [#] + [9] + | [1] = on | [0] = off |
| Reset PIN Code | | [#] + [0] + | [1] = 1111 | Selected by user |

| Parameter | Symbol | Procedure: [PG] + [0] + (Password) + | Default | Options |
|-----------------------------|--------|---|--|---------------------------------|
| Flash 1 During LD | | [#] + [*] + | [1] = on | [0] = off |
| Flash 2 During LD | | [#] + [#] + | [0] = off | [1] = on |
| Extended LCD Symbols | | [9] + [1] + | [0] = off | [1] = on |
| Tx Soft Clip, Handsfree | | [9] + [2] + | [1] = on | [0] = off |
| Rx Soft Clip, Handsfree | | [9] + [3] + | [1] = on | [0] = off |
| Voice Switching, Speed | | [9] + [4] + | [1] = x 2 | [0] = x 1; [2] = x 4; [3] = x 8 |
| Handset/Headset Volume | | [9] + [5] + | [1] = reset by on/off-hook | [0] = setting is maintained |
| LCD Test | | [9] + [6] | Turns on all segments, pressing any further key turns on all digits "1" and all symbols off. | |
| Temporary MF by * with tone | | [9] + [7] + | [0] = off | [1] = on |
| Key Lock Function | | [9] + [8] + | [1] = available | [0] = not available |
| Pin Select "DM/HM" | DM/HM | [9] + [9] + | [1] = MF/LD | [0] = Handset/Headset |
| Ringer Off Function | | [9] + [0] + | [1] = available | [0] = not available |
| Key Test | | [9] + [*] + | Any key pressure turns the LED on | |
| Volume Control on Handset | | [9] + [#] + | [1] = enabled | [0] = disabled |

The above parameters are programmable using a password (0123) through external EEPROM. All procedures must be terminated by pressing the [PG] key. Software for factory settings is available on request.

The programming of timings is done by using a HEX data code as follows:

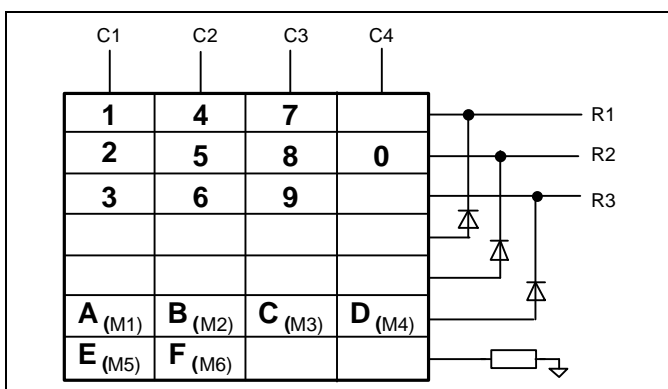

Figure 5: Keys for HEX-code entry

$$Data = 4096 - (f_{osc} / (512 * 12)) * T$$

(T = Time; f_{osc} = 3.58 MHz)

Table 4: Timing selection by HEX code

| Parameter | Default | HEX | Binary Data |
|-------------------|---------|-----|----------------|
| Inter-digit pause | 840 ms | E17 | 1111 0001 0111 |
| Tone duration | 82 ms | FD0 | 1111 1101 0000 |
| Inter-tone pause | 82 ms | FD0 | 1111 1101 0000 |
| Flash 1 | 101 ms | FC4 | 1111 1100 0100 |
| Flash 2 | 285 ms | F5A | 1111 0101 1010 |
| Pause 1 | 1 sec | DB9 | 1101 1011 1001 |
| Pause 2 | 3 sec | 92C | 1001 0010 1100 |
| Post-digit pause | 33 ms | FED | 1111 1110 1101 |
| Post-flash pause | 274 | F60 | 1111 0110 0000 |

Table 5: User programming with PIN code

| Function | Symbol | Procedure | Options |
|---|--------|----------------------------------|--|
| Call Restriction 1 | CR1 | [PG] + [1] + (PIN) + [*] + [1] + | Key in two digits, use [MT] for blank |
| Call Restriction 2 | CR2 | [PG] + [1] + (PIN) + [*] + [2] + | Key in two digits, use [MT] for blank |
| Key Lock | | [PG] + [1] + (PIN) + [#] + [6] + | [0] = unlocked and [1] = locked |
| Clear All Memories | | [PG] + [1] + (PIN) + [#] + [7] + | Press [1] to clear |
| Reset To Factory Settings | | [PG] + [1] + (PIN) + [#] + [8] + | Press [1] to reset |
| Change PIN Code | PIN | [PG] + [1] + (PIN) + [0] + | Key in new PIN + new PIN |
| Press [PG] to store setting and terminate procedure | | | |

Table 6: Mode programming

| Function | Symbol | Procedure | Options |
|---|-----------------|------------------------|--|
| Select Flash | FL | [PG] + [2] + | [0] = Flash 1 and [1] = Flash 2 |
| Select Dialling Mode | DM | [PG] + [3] + | [0] = LD (pulse) and [1] = MF (DTMF) |
| Select Pause Time | P | [PG] + [4] + | [0] = Pause 1 and [1] = Pause 2 |
| Easy Key Lock | | [PG] + [5] + [3] + [9] | Toggles between locked and unlocked |
| Ringer Volume | | [PG] + [6] + | [1] = -16 dB, [2] = -7 dB, and [3] = 0 dB (maximum) |
| Ringer Melody | | [PG] + [7] + | [0] , [1], [2], [3], or [4] |
| LCD Contrast | V ₃₃ | [PG] + [8] + | [1], [2] , or [3] (see also AS2591 data sheet) |
| Bell On/Off | | [PG] + [9] + | [0] = Off and [1] = On |
| Press [PG] to store setting and terminate procedure | | | |

Memory Allocation

The EEPROM memory consists of three areas:

A = factory settings; B = user settings; C = stored numbers

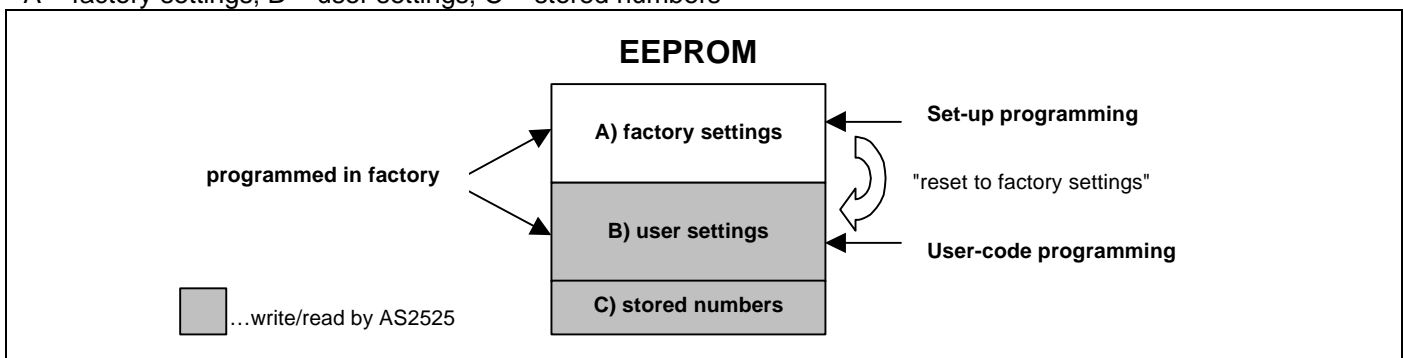

Figure 6: Memory allocation for external EEPROM

The AS2525 is writing and reading to and from area B and C during normal operation and user-code programming. Area A is protected during normal operation and contains a back-up copy of the factory settings. This back-up copy can be loaded into area B by the user with the user-code programming procedure "reset to factory settings". The only way to change the factory settings in area A is by set-up programming using password. After changing area A by set-up programming, the AS2525 automatically performs a "reset to factory settings" to load this changes also into area B.

Functional Description

DC Conditions

The normal operating mode is from 15 mA to 100 mA. An operating mode with reduced performance is from 5 mA to 15 mA. In the line-hold range from 0 mA to 5 mA the device is in a power down mode.

The dc characteristic is determined by the voltage at LI pin and a 30 Ω resistor between pin LI and LS. It can be calculated by the following equation:

$$V_{LS} = V_{LI} + I_{LINE} * 30 \Omega$$

V_{LI} can be programmed to be 3.5 V or 4.5 V.

Table 7: DC mask selection

| [PG] + [0] + (Password) + [#] + [3] + (digit) + [PG] | |
|--|---|
| Digit | DC Mask (dc voltage at pin LI) |
| [0] | Low dc mask, $V_{LI} = 3.5$ Volt |
| [1] | High dc mask, $V_{LI} = 4.5$ Volt |

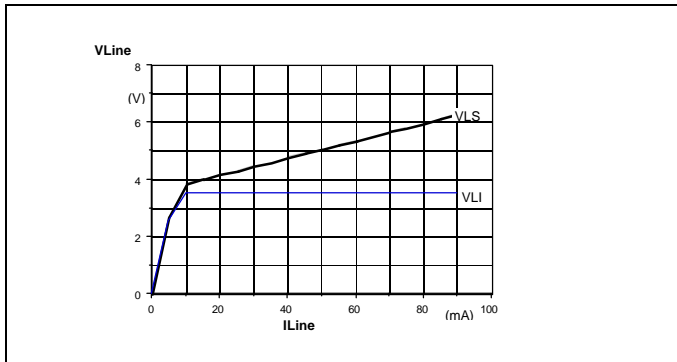

Figure 7: DC characteristic with low dc mask

2/4 Wire Conversion

AS2525 has a built-in dual Wheatstone bridge with one common ground. This provides a maximum of independence of ac impedance and side-tone from each other. One can adapt side-tone without changing the ac impedance.

AC Impedance

The ac impedance of AS2525 is set to 1000 Ω. A complex impedance can be adjusted by connecting an external capacitor to the CI pin. With an external resistor of approximately 1.5 kΩ connected to the LS pin, it can be programmed to 600 Ω.

$$Z_{AC(syn)} = 33 * 30 \Omega$$

Side-Tone

A good side-tone cancellation can be achieved by using the following equation:

$$Z_{BAL} / Z_{LINE} = 10$$

This is assuming that the side-tone reference resistor, R2 (between LI and STB) is 300 Ω and R1 is 30 Ω.

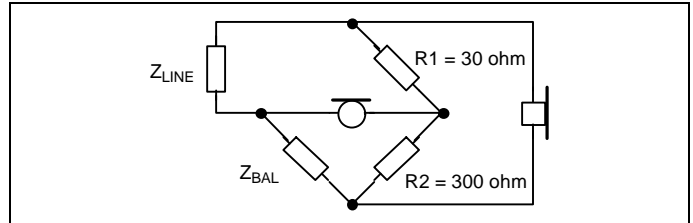

Figure 8: Side-tone balance

Transmit Path

The gain of the M1/M2 → LS path is default set to 37 dB. This gain can be changed from 30 dB to 45 dB in 1 dB steps by set-up programming.

Table 8: Handset Tx gain setting

| [PG] + [0] + (Password) + [0] + [1] + (x) + [PG] | | | |
|--|-------------------------|---------|-------------------------|
| Key (x) | Tx Gain (dB) M1/2 to LS | Key (x) | Tx Gain (dB) M1/2 to LS |
| [0] | 30 | [8] | 38 |
| [1] | 31 | [9] | 39 |
| [2] | 32 | [M1] | 40 |
| [3] | 33 | [M2] | 41 |
| [4] | 34 | [M3] | 42 |
| [5] | 35 | [M4] | 43 |
| [6] | 36 | [M5] | 44 |
| [7] | 37 | [M6] | 45 |

The input is differential with an impedance of 10 kΩ. The soft clip circuit limits the output voltage swing at pin LS to 2 V_{PEAK} when activated.

Table 9: Handset Tx soft clipping selection

| [PG] + [0] + (Password) + [#] + [4] + (digit) + [PG] | |
|--|--|
| Digit | Handset Tx Soft Clipping |
| [0] | Disabled |
| [1] | Enabled (2 V_{PEAK}) |

There is optional LLC for this path.

The gain of the M3/M4 → LS path is default set to 46 dB. This gain can be changed from 39 dB to 54 dB in 1 dB steps by set-up programming.

Table 10: Handsfree Tx gain setting

| [PG] + [0] + (Password) + [0] + [3] + (x) + [PG] | | | |
|--|----------------------------|---------|----------------------------|
| Key (x) | Tx Gain (dB) M3/4 to LS | Key (x) | Tx Gain (dB) M3/4 to LS |
| [0] | 39 | [8] | 47 |
| [1] | 40 | [9] | 48 |
| [2] | 41 | [M1] | 49 |
| [3] | 42 | [M2] | 50 |
| [4] | 43 | [M3] | 51 |
| [5] | 44 | [M4] | 52 |
| [6] | 45 | [M5] | 53 |
| [7] | 46 | [M6] | 54 |

The input is differential with an impedance of 10 kΩ.

The soft clip circuit limits the output voltage swing at pin LS to $2 V_{PEAK}$ when activated.

Table 11: Handsfree Tx soft clipping selection

| [PG] + [0] + (Password) + [9] + [2] + (digit) + [PG] | |
|--|---------------------------------|
| Digit | Handsfree Tx Soft Clipping |
| [0] | Disabled |
| [1] | Enabled ($2 V_{PEAK}$) |

There is no LLC option for this path.

Receive Path

The gain of the LS → RO receive path is default set to 1 dB. This gain can be changed from -6 dB to 9 dB in 1 dB steps by set-up programming.

Table 12: Handset Rx gain setting

| [PG] + [0] + (Password) + [0] + [2] + (x) + [PG] | | | |
|--|--------------------------|---------|--------------------------|
| Key (x) | Rx Gain (dB) LS to RO | Key (x) | Rx Gain (dB) LS to RO |
| [0] | -6 | [8] | 2 |
| [1] | -5 | [9] | 3 |
| [2] | -4 | [M1] | 4 |
| [3] | -3 | [M2] | 5 |
| [4] | -2 | [M3] | 6 |
| [5] | -1 | [M4] | 7 |
| [6] | 0 | [M5] | 8 |
| [7] | 1 | [M6] | 9 |

The user can also change the gain within this range in 4 dB steps via the [V+]/[V-] keys. The receive default gain in handset and headset mode must lie between position 5 and 9 for correct operation of the volume control. The receive input is the differential signal of RI and STB. The soft clip circuit limits the output

voltage at RO to $1 V_{PEAK}$. It prevents harsh distortion and acoustic shock.

Table 13: Handset Rx soft clipping selection

| [PG] + [0] + (Password) + [#] + [5] + (digit) + [PG] | |
|--|-------------------------------------|
| Digit | Handset Rx Soft Clipping (Earpiece) |
| [0] | Disabled |
| [1] | Enabled |

There is LLC option for this path.

The gain of the LS → LO1/LO2 receive path is set to 29 dB.

This gain can be changed by set-up programming from 22 dB to -37 dB in 1 dB steps.

Table 14: Loudspeaker gain setting

| [PG] + [0] + (Password) + [0] + [4] + (x) + [PG] | | | |
|--|-----------------------------|---------|-----------------------------|
| Key (x) | Rx Gain (dB) LS to LO1/2 | Key (x) | Rx Gain (dB) LS to LO1/2 |
| [0] | 22 | [8] | 30 |
| [1] | 23 | [9] | 31 |
| [2] | 24 | [M1] | 32 |
| [3] | 25 | [M2] | 33 |
| [4] | 26 | [M3] | 34 |
| [5] | 27 | [M4] | 35 |
| [6] | 28 | [M5] | 36 |
| [7] | 29 | [M6] | 37 |

The user can also change the gain using the [V+]/[V-] keys (see section "Handsfree"). The volume range is 15 dB (-7/+8 dB).

The receive input is the differential signal of RI and STB. The soft clip circuit limits the output voltage swing at LO1/LO2 to $1 V_{PEAK}$.

Table 15: Loudspeaker soft clipping selection

| [PG] + [0] + (Password) + [9] + [3] + (digit) + [PG] | |
|--|--|
| Digit | Handsfree Rx Soft Clipping (Loudspeaker) |
| [0] | Disabled |
| [1] | Enabled |

There is optional LLC for this path.

Line Loss Compensation (LLC)

The line loss compensation is set-up programmable and effects only the handset mode.

Table 16: Line loss compensation selection

| [PG] + [0] + (Password) + [0] + [5] + (digit) + [PG] | |
|--|--|
| Digit | LLC Range |
| [0] | No LLC (gain independent of line current) |
| [1] | -1 dB/5 mA from 20 to 50 mA |
| [2] | -1 dB/5 mA from 45 to 75 mA |

When it is activated, the transmit and receive gains for both channels are decreased by 6 dB at line currents from 20 mA to 50 mA or from 45 mA to 75 mA depending on selected range.

Handsfree

The handsfree function allows voice communication without using the handset (full 2-way speaker phone). Two voice controlled attenuators prevent acoustic coupling between the loudspeaker and the handsfree microphone.

The voice switching circuit has three states, namely idle, transmit or receive. In receive mode the attenuation of the receive path and the transmit path can be controlled by the volume keys between 0 dB and -15 dB. The following table (Table 18: Handsfree

attenuation scheme) shows how voice switching is controlled.

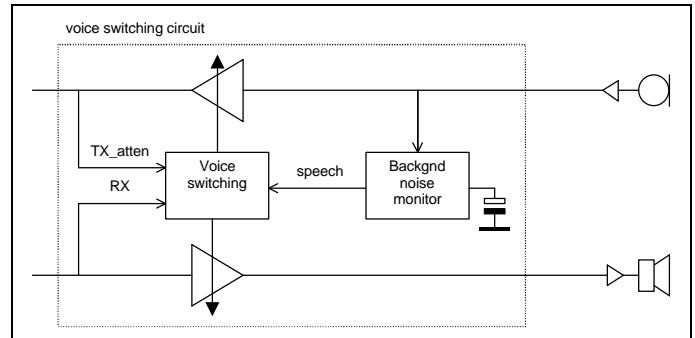

Figure 9: Handsfree voice switching

A background monitoring circuit is incorporated. This circuit can be enabled/disabled as required.

Table 17: Background noise monitoring selection

| [PG] + [0] + (Password) + [#] + [6] + (digit) + [PG] | |
|--|-----------------------------|
| Digit | Background Noise Monitoring |
| [0] | Disabled |
| [1] | Enabled |

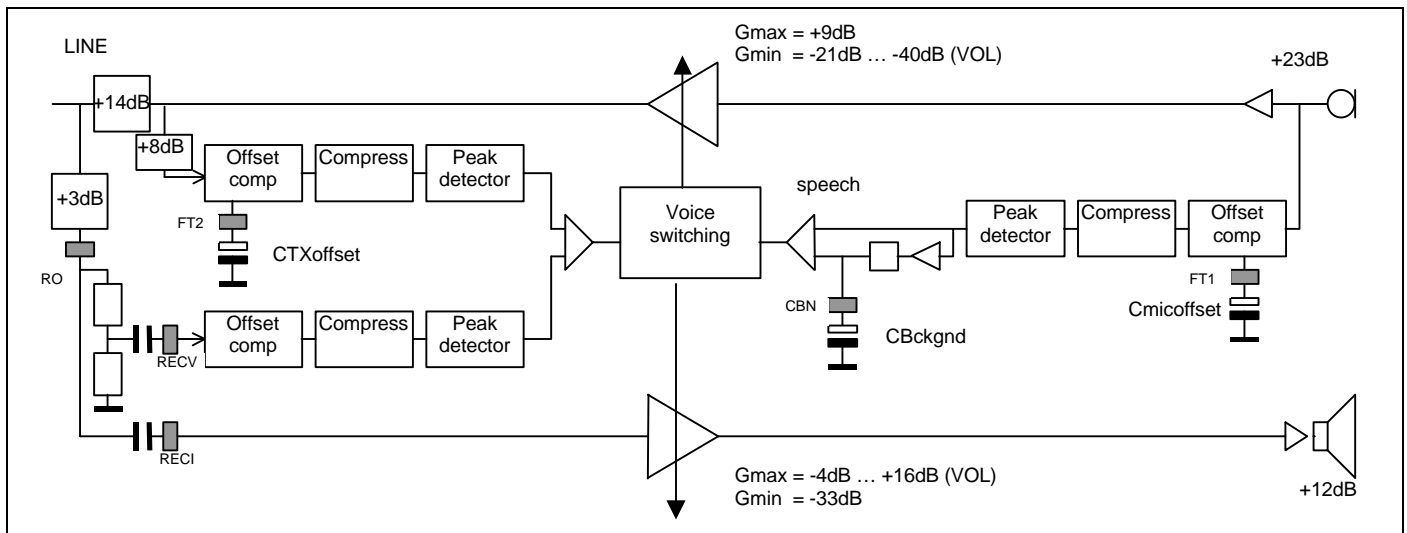

Figure 10: Signal path of handsfree circuit

Table 18: Handsfree attenuation scheme

| | Speech | Mode | RX-gain | TX-gain | Remark |
|---------------|--------|----------|----------------|------------------|---|
| RX > TX_atten | X | Receive | 0 dB to -20 dB | -50 dB to -30 dB | adjustable with [V+]/[V-] keys in 8 steps |
| TX_atten > RX | No | Idle | -25 dB | -25 dB | middle position |
| TX_atten > RX | Yes | Transmit | -50 dB | 0 dB | independent of [V+]/[V-] keys |

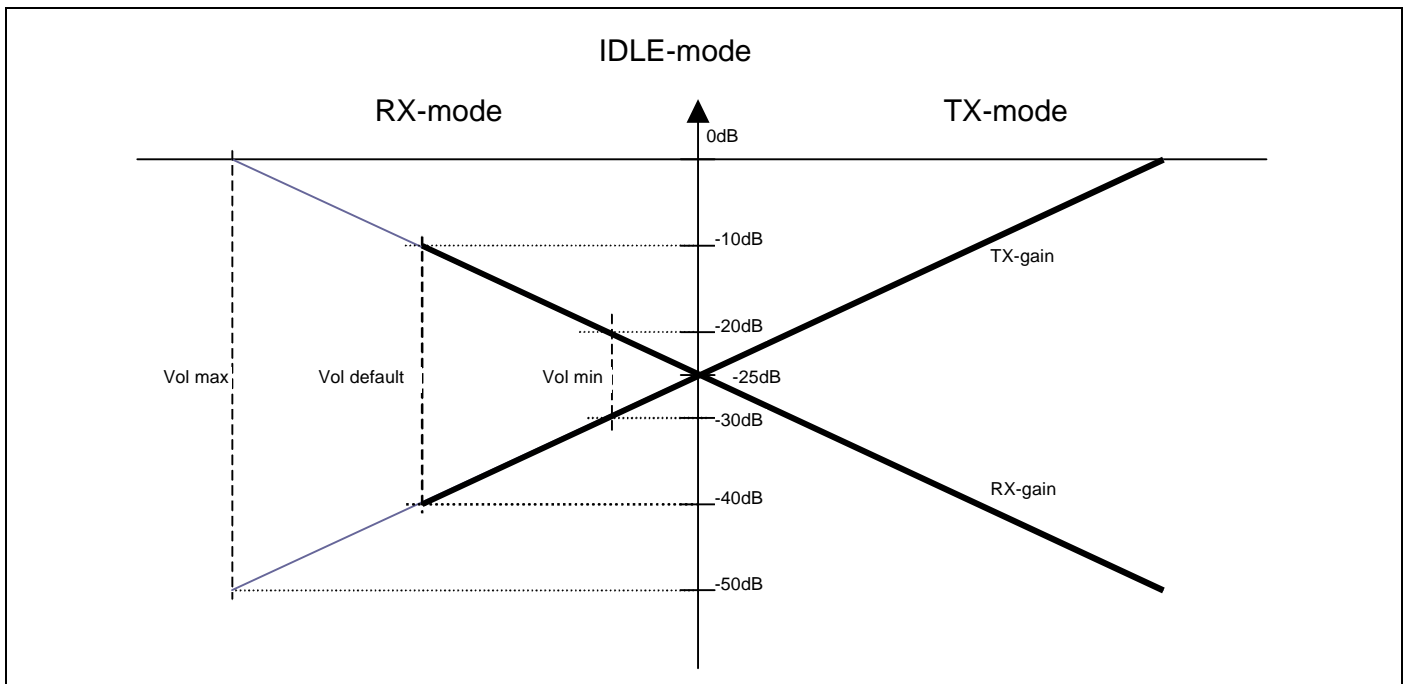

Figure 11: Gain transition of voice switching

Loudhearing

A loudhearing mode can be enabled/disabled through the set-up programming.

Table 19: Loudhearing mode selection

| [PG] + [0] + (Password) + [#] + [7] + (digit) + [PG] | |
|--|---------------------------------------|
| Digit | Loudhearing |
| [0] | Enabled (LH + HF provided) |
| [1] | Disabled (only HF is provided) |

Headset mode

Head set mode is selected by connecting pin "HEAD" to V_{DD} and enabling the head function by service code programming (see also Table 3: Parameter settings).

Table 20: Headset Tx gain setting

| [PG] + [0] + (Password) + [0] + [7] + (x) + [PG] | | | |
|--|-------------------------|---------|-------------------------|
| Key (x) | Tx Gain (dB) M1/2 to LS | Key (x) | Tx Gain (dB) M1/2 to LS |
| [0] | 30 | [8] | 38 |
| [1] | 31 | [9] | 39 |
| [2] | 32 | [M1] | 40 |
| [3] | 33 | [M2] | 41 |
| [4] | 34 | [M3] | 42 |
| [5] | 35 | [M4] | 43 |
| [6] | 36 | [M5] | 44 |
| [7] | 37 | [M6] | 45 |

Table 21: Headset Rx gain setting

| [PG] + [0] + (Password) + [0] + [8] + (x) + [PG] | | | |
|--|--------------------------|---------|--------------------------|
| Key (x) | Rx Gain (dB) LS to RO | Key (x) | Rx Gain (dB) LS to RO |
| [0] | -6 | [8] | 2 |
| [1] | -5 | [9] | 3 |
| [2] | -4 | [M1] | 4 |
| [3] | -3 | [M2] | 5 |
| [4] | -2 | [M3] | 6 |
| [5] | -1 | [M4] | 7 |
| [6] | 0 | [M5] | 8 |
| [7] | 1 | [M6] | 9 |

If this mode is entered both hook inputs HS and HF act as electronic off-hook for handset operation. The gain in transmit and receive can be programmed by service code programming. The pin "HEAD" is only scanned once after off-hook and any change on this pin during one session will be ignored.

Ring Frequency Detection

The ring frequency detector assures that only signals with a frequency between 13 Hz and 70 Hz are regarded as valid ring signals.

When a valid ring signal is present for 100 ms continuously, the melody generator is activated and remains active as long as the ring signal is present.

Once the melody generator has been started, the ring signal is continuously monitored and the melody generator is instantly turned on or off according to the momentary presence of a valid or invalid ring signal respectively (until next POR or off-hook).

DC/DC converter

When a valid ring signal is detected, the dc/dc converter is started.

Dialling and Control Functions

Valid Keys

The key scanning is enabled in off-hook mode with V_{DD} above V_{REF} . A valid key is detected from the keyboard by connecting the appropriate row to the column ($R_{ON} < 1 \text{ k}\Omega$). This can be done using an $n \times m$ keyboard matrix with single contacts. Three diodes and a resistor are used to extend the number of rows (see Figure 4: Keyboard Layout).

PIN Code

A PIN code is available for protection various user settings. The default PIN code is set to 1111 and can be change as follows:

1. Press **[PG]** to enter programme mode
2. Press **[1]** + (PIN) + **[0]**
3. Key in new PIN code (valid digits: 0 - 9, #)
4. Key in new PIN code again
5. Press **[PG]** (= store and exit) or go on-hook to abort

It is also possible to reset the PIN code through set-up programming:

1. Press **[PG]** to enter programme mode
2. Press **[0]** + (Password) + **[#]** + **[0]**
3. Press **[1]** to reset
4. Press **[PG]** (= store and exit) or go on-hook to abort

Call Restriction

A call restriction function is accommodated. This function can be activated using the PIN code.

Storing digits for call restriction:

1. Press **[PG]** to enter programme mode
2. Press **[1]** + (PIN) + **[*]**
3. Press **[1]** for first call restriction and **[2]** for second call restriction
4. Key in digits for call restriction (2 digits, [MT] for blank)

5. Press **[PG]** (= store and exit) or go on-hook to abort.

Key Lock

A key lock function is provided to allow the user to protect the telephone from any mis-use. When this function is available through the set-up programming, it is possible to enable/disable the key lock using the user PIN code.

Enabling/disabling key lock:

1. Press **[PG]** to enter programme mode
2. Press **[1]** + (PIN) + **[#]** + **[6]**
3. Press **[1]** for enable or **[0]** for disable
4. Press **[PG]** (= store and exit) or go on-hook to abort

Also an easy key lock function is provided. This function can be activated/disactivated when the key lock function is available through set-up programming and the previous mentioned key lock through PIN code is disabled.

Clear Memory Procedure

It is possible to clear all stored numbers by using the PIN code as follows:

1. Press **[PG]** to enter programme mode
2. Press **[1]** + (PIN) + **[#]** + **[7]**
3. Press **[1]** for clear
4. Press **[PG]** (= store and exit) or go on-hook to abort

Reset to Factory Settings

It is possible to reset all settings to the default factory settings with following procedure:

1. Press **[PG]** to enter programme mode
2. Press **[1]** + (PIN) + **[#]** + **[8]**
3. Press **[1]** for reset
4. Press **[PG]** (= store and exit) or go on-hook to abort

Dial Mode Selection

The default signalling mode (LD or MF) is selectable through following procedure:

1. Press **[PG]** to enter programme mode
2. Press **[3]** to enter dial select mode
3. Press **[0]** for LD and **[1]** for MF
4. Press **[PG]** (= store and exit) or go on-hook to abort

When default LD mode is selected, a temporary change to MF can be invoked by pressing the **[*]** key. Temporary MF select with tone on first key pressure can be selected as option (see also Table 3: Parameter settings). The circuit will revert to LD by pressing the **[FL]** key or by next on-hook.

Re-Dialling (Last Number Redial)

Re-dialling is a facility that allows re-signalling of the last dialled number without keying in all the digits again. Numbers dialled out from any memory will also be stored in the LNR memory. The re-dialling works in following manner:

- Any digit (including Flash, Pause, and MF select) being dialled is storable in the LNR memory up to a total of 31 digits.
- If more than 31 digits are entered, re-dialling will be inhibited.
- Pressing the **[R/P]** key as first entry after off-hook (LNR cursor at first digit) will invoke dialling the content of the LNR memory.
- If the **[R/P]** key is pressed after entering one or more digits, the key will function as a pause key and each pressure will insert a pause.

Pauses can also be inserted by pressing the **[R/P]** key in programme mode.

Flash Function

A flash, **[FL]** key, activation will invoke a timed loop break. The flash duration can be programmed through set-up (see Figure 5: Keys for HEX-code entry and Table 4: Timing selection by HEX code):

Table 22: Flash duration setting

| [PG] + [0] + (Password) + [*] + (digit) + (HEX) + [PG] | | |
|--|----------|----------------|
| Digit | Timing | Flash Duration |
| [4] | HEX code | Flash 1 |
| [5] | HEX code | Flash 2 |

One of two pre-programmed can be selected as follows:

1. Press **[PG]** to enter programme mode
2. Press **[2]** to enter flash select mode
3. Press **[0]** for duration 1 and **[1]** for duration 2
4. Press **[PG]** (= store and exit) or go on-hook to abort

A flash entered will be stored in the LNR memory together with entered digits. After a recall a 270 ms pause will automatically be executed.

Pauses

Pauses can be inserted if the **[R/P]** key is pressed after entering one or more digits. Also during programming, pauses can be inserted by pressing the **[R/P]** key. Default pause duration is 1 second (P1) and an alternative pause of 3 second (P2) can be selected. These pauses can be changed through the set-up programming (see Table 3: Parameter settings)

Memory Keys

The keys **[M1]** to **[M8]** are direct memory access keys, **[SH]** key is used to access second level of direct memories, and the **[MR]** key is used for key-code dialling. Up to 26 numbers can be stored in the on-chip RAM. Each number can contain up to 21 digits (including pauses).

During programming multiple pauses can be inserted by pressing the **[RD]** key.

Example (45678P123 is stored in M1, where P is a pause and 123 the extension number):

1. Off-hook, wait for dial tone
2. Press **[M1]**
 - 45678 is dialled out
 - Dialling halts (pauses)
 - Dialling is resumed, 123 is dialled out.

Memory dialling is cascable up to a the maximum of 31 digits/data.

Tone Generator

The tone generator incorporates the DTMF tones, 3 frequencies for the tone ringer and pacifier tones.

DTMF

The DTMF generator provides 7 frequencies.

Table 23: DTMF frequencies

| Digit | Frequency |
|----------------|-------------------|
| <i>Rows</i> | <i>Low Group</i> |
| 1 - 2 - 3 | 697 Hz |
| 4 - 5 - 6 | 770 Hz |
| 7 - 8 - 9 | 852 Hz |
| * - 0 - # | 941 Hz |
| <i>Columns</i> | <i>High Group</i> |
| 1 - 4 - 7 - * | 1209 Hz |
| 2 - 5 - 8 - 0 | 1336 Hz |
| 3 - 6 - 9 - # | 1477 Hz |

The MF output level can be set through set-up programming. The range is from -18 dBm to -6 dBm in 1 dB steps.

Table 24: DTMF level settings

| [PG] + [0] + (Password) + [0] + [7] + (x) + [PG] | | | |
|--|---------------------------------|---------|---------------------------------|
| Key (x) | Level (dBm) <i>Low Group</i> | Key (x) | Level (dBm) <i>Low Group</i> |
| [0] | -18 | [7] | -11 |
| [1] | -17 | [8] | -10 |
| [2] | -16 | [9] | -9 |
| [3] | -15 | [M1] | -8 |
| [4] | -14 | [M2] | -7 |
| [5] | -13 | [M3] | -6 |
| [6] | -12 | | |

The pre-emphasis is 2.6 dB. The DTMF tones are according to CEPT recommendations.

Tone Ringer (Melody/Volume)

The tone ringer incorporates two basic selection, namely 2-tone or 3-tone melodies. The default set-up selection is the 3-tone ringer.

Table 25: Basic ringer melody selection

| [PG] + [0] + (Password) + [#] + [8] + (digit) + [PG] | |
|--|---------------|
| Digit | Ringer Melody |
| [0] | 2-tone |
| [1] | 3-tone |

The user can chose the following melodies as shown in below table.

Table 26: 3-tone melody programming

| Procedure | Digit | Sequence | Rate |
|-----------------------------------|-------|-------------------|------|
| [PG] + [7] + | [0] | F1 F2 F3 F1 F2 F3 | 1 |
| | [1] | F1 F2 F3 F1 F2 F3 | 2 |
| | [2] | F1 F2 F3 F1 F2 F3 | 4 |
| | [3] | F1 F2 F3 F1 F2 F3 | 6 |
| | [4] | F1 F2 F3 F1 F2 F3 | 10 |
| Press [PG] to store and terminate | | | |

The chosen melody will be heard in the loudspeaker during programming. Pressing the [PG] key will end the procedure and the last selected melody will be stored.

When 2-tone melody is selected through the set-up procedure, it is possible to chose the following melodies:

Table 27: 2-tone melody programming

| Procedure | Digit | Sequence | Rate |
|-----------------------------------|-------|-------------------|------|
| [PG] + [7] + | [0] | F1 F2 F1 F2 F1 F2 | 2 |
| | [1] | F1 F2 F1 F2 F1 F2 | 5 |
| | [2] | F1 F3 F1 F3 F1 F3 | 2 |
| | [3] | F1 F3 F1 F3 F1 F3 | 5 |
| | [4] | F2 F3 F2 F3 F2 F3 | 2 |
| Press [PG] to store and terminate | | | |

Repetition rate means that a sequence of 6 frequencies is repeated 1, 2, 4, 5, 6 or 10 times within 1 second.

Pacifier Tone

Any key entry is acknowledged by a pacifier tone (key-in tone) of 1333 Hz. The pacifier tone can be enabled/disabled through set-up programming.

Table 28: Pacifier tone selection

| [PG] + [0] + (Password) + [#] + [9] + (digit) + [PG] | |
|--|-----------------------------|
| Digit | Pacifier Tone (Key-in Tone) |
| [0] | Disabled |
| [1] | Enabled |

Table 29: Pacifier tones

| Key Entry | Frequency | Duration |
|------------------|-----------|-----------|
| Acknowledge | 1333 Hz | 40 ms |
| Reject/Terminate | 1333 Hz | 4 x 40 ms |

An invalid key entry will be indicated by a rejection tone of 4 times 40 ms.

By MF dialling the DTMF tones are provided to the earpiece as comfort tone. The level of the comfort is selected through the set-up programming.

Table 30: DTMF comfort tone level setting

| [PG] + [0] + (Password) + [0] + (y + x) + [PG] | | | |
|--|----------------------|-------------|-------------------------|
| Key (y + x) | Level (dBr) Earpiece | Key (y + x) | Level (dBr) Loudspeaker |
| [9] + [0] | -36 | [0] + [0] | -15 |
| [9] + [1] | -30 | [0] + [1] | -9 |
| [9] + [2] | -24 | [0] + [2] | -3 |
| [9] + [3] | -18 | [0] + [3] | 3 |

Serial Bus

The AS2525 incorporates a serial bus (DO, DI, and CLK) with two chip select outputs (CS1 and CS2). The serial bus is used to:

- sending data to the LCD driver (AS2591) when a key is pressed or a number is dialled out
- reading and writing to the external EEPROM under following conditions:

Table 31: EEPROM read/write timings

| ACTION | DURATION |
|--------------------------------|-------------|
| After off-hook (debounced) | 50 ms |
| After on-hook (debounced) | 200 ms |
| After first rising edge at FCI | 10 ms |
| After PG is terminated | 12...600 ms |
| After pressing [V+]/[V-] | 20 ms |

See also AS2591 data sheet for further information.

LCD Control

The AS2525 is designed to work together with the LCD driver AS2591 (see also AS2591 data sheet).

Electrical Characteristics

Absolute Maximum Ratings*

| | |
|--------------------------------|--|
| Supply Voltage..... | $-0.3 \leq V_{DD} \leq 7V$ |
| Input Current..... | $\pm 25 \text{ mA}$ |
| Input Voltage (LS)..... | $-0.3V \leq V_{IN} \leq 12V$ |
| Input Voltage (LI, CS)..... | $-0.3V \leq V_{IN} \leq 8V$ |
| Input Voltage (STB, RI)..... | $-2V \leq V_{IN} \leq V_{DD} + 0.3V$ |
| Digital Input Voltage..... | $-0.3V \leq V_{IN} \leq V_{DD} + 0.3V$ |
| Electrostatic Discharge..... | $\pm 1000V$ |
| Storage Temperature Range..... | $-65 \text{ to } +125^\circ\text{C}$ |
| Total Power Dissipation..... | 500mW |

*Exceeding these figures may cause permanent damage. Functional operation under these conditions is not permitted.

Recommended Operating Range

| Symbol | Parameter | Conditions | Min. | Typ.* | Max. | Units |
|-----------|---------------------------------------|---------------------------------------|------|-------|------|------------------|
| V_{DD} | Supply Voltage (internally generated) | Speech mode | 3.0 | | 5.0 | V |
| T_{AMB} | Ambient Operating Temp. Range | | -25 | | +70 | $^\circ\text{C}$ |
| f_{OSC} | Oscillator Frequency | Resonator: Murata CSA 3.58M G312AM | | 3.58 | | MHz |

* Typical figures are at 25°C and are for design aid only; not guaranteed and not subject to production testing.

DC Characteristics

($I_{LINE} = 15 \text{ mA}$, recommended operating conditions unless otherwise specified)

| Symbol | Parameter | Conditions | Min. | Typ. | Max. | Units |
|--------------|--|--|--------------|------|--------------|---------------|
| I_{DD} | Operating Supply Current | Speech mode | | 4 | 6 | mA |
| | | Handsfree mode | | 11 | 13 | mA |
| | | LD dialling, $V_{DD} = 2.5V$ | | 200 | | μA |
| | | Ring mode, $V_{DD} = 2.5V$ | | 300 | | μA |
| I_{DD-EXT} | Available Supply Current for Peripheral Circuits | Speech mode or MF dialling | 2 | | | mA |
| I_{DD0} | Idle Current | Idle mode, $V_{DD} = 2 \text{ V}$, $T_{AMB} = 25^\circ\text{C}$ | | 2 | | μA |
| V_{LI} | Line Voltage, LIVolt = 0 Line Voltage, LIVolt = 1 | $13 \text{ mA} < I_{LINE} < 100 \text{ mA}$ | 3.2 | 3.5 | 3.8 | V |
| | | | 4.2 | 4.5 | 4.8 | V |
| I_{OL} | Output Current, Sink Pin CS, SS | $V_{OL} = 0.4V$ | | 1 | | mA |
| V_{IL} | Input Low Voltage | $T_{AMB} = 25^\circ\text{C}$ | V_{SS} | | $0.3 V_{DD}$ | V |
| V_{IH} | Input High Voltage | $T_{AMB} = 25^\circ\text{C}$ | $0.7 V_{DD}$ | | V_{DD} | V |

AC Electrical Characteristics

$I_{LINE} = 15 \text{ mA}$; $f = 800 \text{ Hz}$; $Z_{AC} = 1000\Omega$; recommended operating conditions and default settings unless otherwise specified.

Transmit

| Symbol | Parameter | Conditions | Min. | Typ. | Max. | Units |
|--------------|---|---|------|---------|------|--------------------------|
| A_{TX} | Transmit Gain, default | M1/M2 to LS | 34.3 | 35.8 | 37.3 | dB |
| | | M3/M4 to LS | 42.0 | 44.0 | 46.0 | dB |
| | Variation with Frequency | $f = 500 \text{ Hz to } 3.4 \text{ kHz}$ | | +/- 0.8 | | dB |
| THD | Distortion | $V_{LS} < 0.25 V_{RMS}$ | | | 2 | % |
| V_{AGC} | Soft Clip Level | $V_{LS} =$ | | 2 | | V |
| A_{SCO} | Soft Clip Overdrive | | | 20 | | dB |
| t_{DECAY} | Attack Time | | | 70 | | $\mu\text{s}/6\text{dB}$ |
| t_{DECAY} | Decay Time | | | 100 | | $\text{ms}/6\text{dB}$ |
| Z_{IN} | Input Impedance; M1/M2 | | | 10 | | $\text{k}\Omega$ |
| | Input Impedance; M3/M4 | | | 10 | | $\text{k}\Omega$ |
| A_{MUTE} | Mute Attenuation | Mute activated | 60 | | | dB |
| V_{NO} | Noise Output Voltage | $T_{AMB} = 25^\circ\text{C}$, handset mode $A_{TX} = 37 \text{ dB}$ | | | -72 | dBmp |
| $V_{IN MAX}$ | Input Voltage Range; M1/M2 and M3/M4 | Differential | | +/- 1 | | V_{PEAK} |

Line Driver

| Symbol | Parameter | Test Conditions | Min. | Typ. | Max. | Units |
|----------------------|-------------------------|---|------|-------|------|-------------------------|
| $V_{IN MAX}$ | Input Voltage Range; LI | | | +/- 2 | | V_{PEAK} |
| V_{TX} | Dynamic Range; LI | | | +/- 2 | | V_{PEAK} |
| RL | Return Loss | $Z_{RL} = 1000 \Omega$; $T_{AMB} = 25^\circ\text{C}$ | 18 | | | dB |
| $\Delta Z_{AC/TEMP}$ | Temperature Variation | | | 0.5 | | $\Omega/^\circ\text{C}$ |

Receive

| Symbol | Parameter | Condition | Min. | Typ. | Max. | Units |
|-----------------|-------------------------------|--|------|---------|------|-------------|
| A_{RX} | Receive Gain, Default | LS to RO; volume reset | -2.0 | -0.5 | 1.0 | dB |
| | | LS to LO1/LO2; volume max. | 25.0 | 27.0 | 29.0 | dB |
| A_{RX-VOL} | Volume Control Range | 8 steps through [V-]/[V+] keys | | 15 | | dB |
| ΔA_{RX} | Variation with Frequency | f = 500 Hz to 3.4 kHz | | +/- 0.8 | | dB |
| THD | Distortion, RO | $V_{RO} = 0.25 V_{RMS}$ | | | 2 | % |
| | Distortion, LO1/LO2 | $V_{LO1/2} = 0.25 V_{RMS}$ | | | 5 | % |
| V_{AGC} | Soft Clip Level | $V_{RO} =$ | | 1 | | V_{PEAK} |
| A_{SCO} | Soft Clip Overdrive | | | 10 | | dB |
| t_{DECAY} | Attack Time | $V_{RI} > 0.8 V_{RMS}$ | | 70 | | $\mu s/6dB$ |
| t_{DECAY} | Decay Time | | | 100 | | ms/6dB |
| V_{NO} | Noise Output Voltage, RO | $T_{AMB} = 25^{\circ}C, A_{RX} = 3 dB$ 50 Hz.....20 kHz | | | -72 | dBmp |
| V_{UFC} | Unwanted Frequency Components | | | | -60 | dBmp |
| Z_{IN} | Input Impedance, RI | | | 8 | | k Ω |
| $V_{IN-MAX RI}$ | Input Voltage Range, RI | | | +/- 2 | | V_{PEAK} |
| A_{ST} | Side Tone Cancellation | $V_{RI} < 0.25 V_{RMS}$ | 26 | | | dB |
| Z_{IN} | Input Impedance, STB | | | 80 | | k Ω |
| $V_{IN-MAX ST}$ | Input Voltage Range, STB | | | +/- 2 | | V_{PEAK} |

General Timings

| Symbol | Parameter | Condition | Min. | Typ. | Max. | Units |
|------------|-------------------|---------------------------|------|------|------|-------|
| t_d | Key Debounce Time | | | 15 | | ms |
| t_{HS-L} | Low/High Debounce | HS Input (going off-hook) | | 15 | | ms |
| t_{HS-H} | High/Low Debounce | HS Input (going on-hook) | | 210 | | ms |
| t_{FD} | Flash Duration | FL 1 (default) | 100 | | 102 | ms |
| | | FL 2 (default) | 275 | 285 | 300 | ms |
| t_{PPF} | Post Flash Pause | | | 274 | | ms |
| t_{AP} | Access Pause | P1 (default) | 0.9 | 1.0 | 1.1 | sec. |
| | | P2 (default) | | 3.0 | | sec. |

DTMF

| Symbol | Parameter | Condition | Min. | Typ. | Max. | Units |
|------------------|---------------------------------------|--|------|-------------|--|--|
| DF | Frequency Deviation | Deviation of ceramic resonator is not included | | | 1.2 | % |
| V_{MF} | MF Tone Level at LS (Low Group) | Default | -4.5 | -5.5 | -6.5 | dBm |
| $V_{MF-RANGE}$ | MF Tone Level Range at LS (Low Group) | 13 steps | | -18/-6 | | dBm |
| $\Delta V_{L,H}$ | Pre-emphasis, Low to High | | 2.0 | 2.6 | 3.2 | dBr |
| V_{UFC} | Unwanted Frequency Components | 300 Hz...4.3 kHz 4.3 kHz...7 kHz 7 kHz...10 kHz 10 kHz...14 kHz 14 kHz...28.5 kHz 28.5 kHz...40 kHz | | | - 40 -46 - 52 -58 - 70 - 80 | dBm dBm dBm dBm dBm dBm |
| t_{TD} | Tone Duration, Minimum | Default | 80 | 82.3 | 85 | ms |
| t_{ITP} | Inter Tone Pause, Min. | Default | 80 | 82.3 | 85 | ms |
| t_{TR} | Tone Rise Time | From 10% to 90% amplitude | | | 5 | ms |
| t_{TR} | Tone Fall Time | From 90% to 10% amplitude | | | 5 | ms |
| V_{CT} | Comfort Tone Level, RO | Relative to LS, 4 steps | | - 36 -18 | | dBr |

LD Dialling

| Symbol | Parameter | Condition | Min. | Typ. | Max. | Units |
|-----------|-------------------|-----------------------------|------|--------------------|------|----------------|
| t_{DR} | Dialling Rate | Default Option | 9.53 | 10 20 | 10.5 | pps pps |
| t_{VB} | Break Period | Default Option Option | 57 | 61.2 66 33 | 63 | ms ms ms |
| t_M | Make Period | Default Option Option | 38 | 40.8 33 16.5 | 42 | ms ms ms |
| t_{PDP} | Pre-Digit Pause | | | 35 | | ms |
| t_{IDP} | Inter-Digit Pause | | 800 | | 880 | ms |

Tone Ringer

| Symbol | Parameter | Condition | Min. | Typ. | Max. | Units |
|-----------|--------------------------|-----------|------|------|------|-------|
| F1 | Frequency 1 | | 770 | 800 | 830 | Hz |
| F2 | Frequency 2 | | 1025 | 1067 | 1110 | Hz |
| F3 | Frequency 3 | | 1280 | 1333 | 1385 | Hz |
| t_{DT} | Detection Time | Initial | | 100 | | ms |
| f_{MIN} | Min. Detection Frequency | | 12 | 13 | 14 | Hz |
| f_{MAX} | Max. Detection Frequency | | 68 | 70 | 75 | Hz |

Pacifier Tone

| Symbol | Parameter | Condition | Min. | Typ. | Max. | Units |
|------------|--------------------------|--------------------------------|------|------|------|-------------------|
| V_{PARO} | Tone Output Level, RO | RL = 150 Ω | | 30 | | mV _{P,P} |
| | Tone Output Level, LO1/2 | RL = 32 Ω | | 300 | | mV _{P,P} |
| f_{PT} | Frequency | Key entry | | 1333 | | Hz |
| t_{TBD} | Tone Burst Duration | Key entry | | 40 | | ms |
| | | Acknowledge, terminate PG mode | | 140 | | ms |
| | | Rejection, invalid key entry | | 4x40 | | ms |
| t_{ITP} | Inter-Tone Pause | | | 80 | | ms |

Timing Diagrams

LD dialling

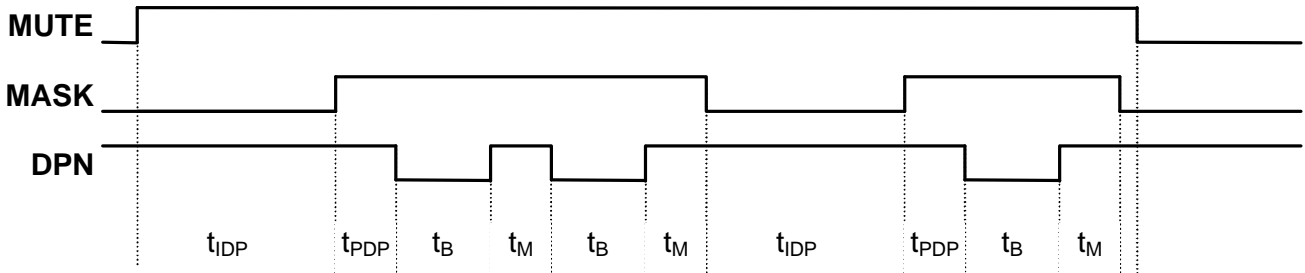

LD dialling with access pause

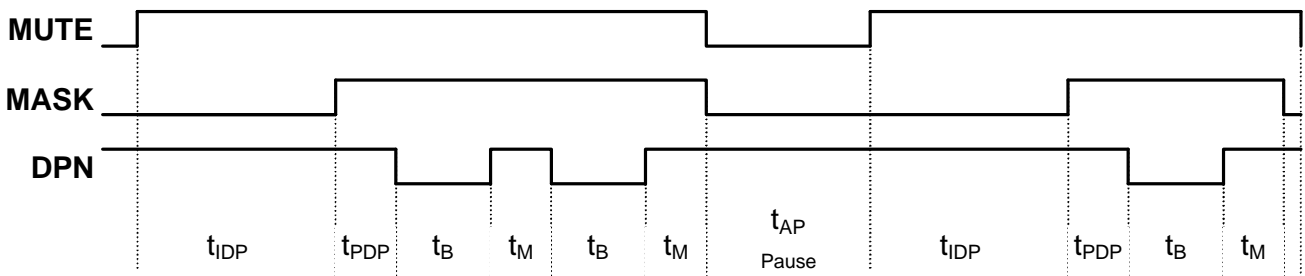

MF dialling

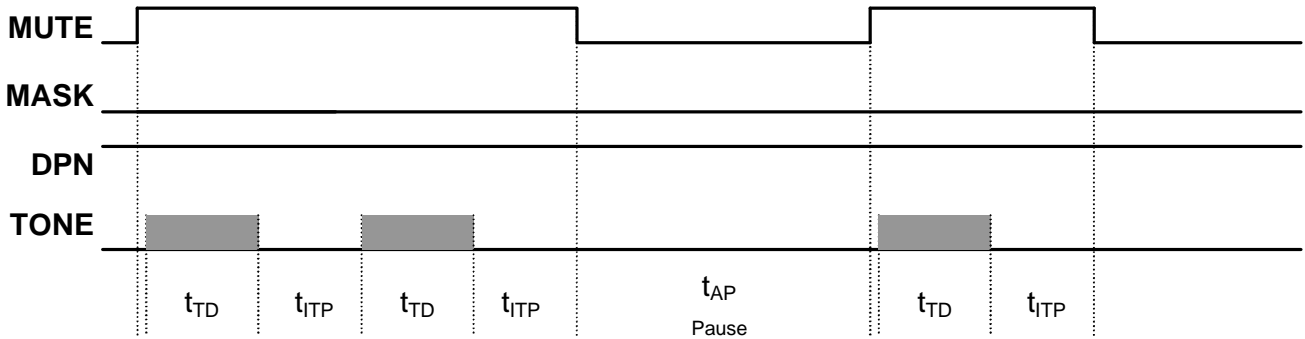

Flash

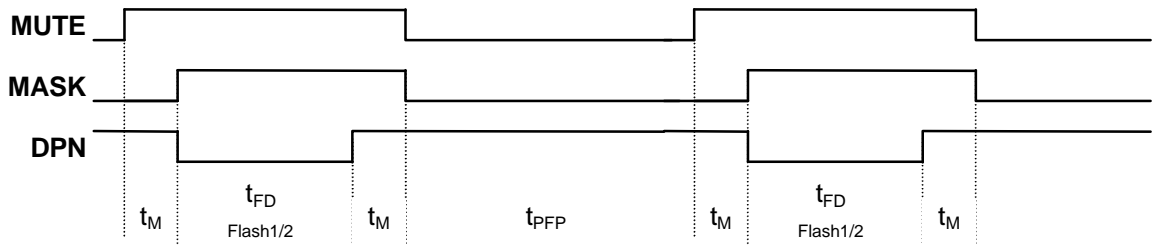

Figure 12: Timing diagrams

Test Circuit

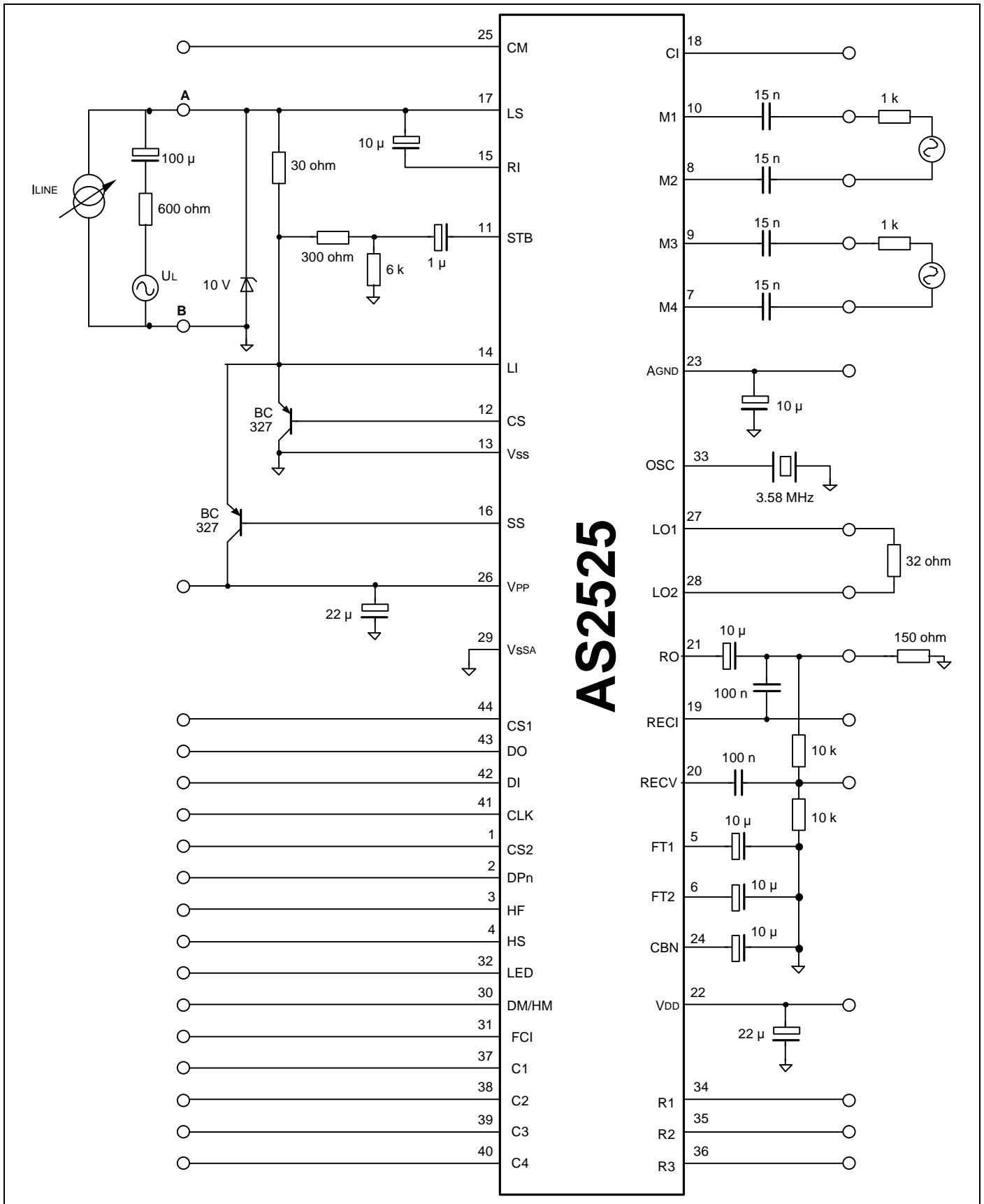

Figure 13: Test circuit

Typical Application

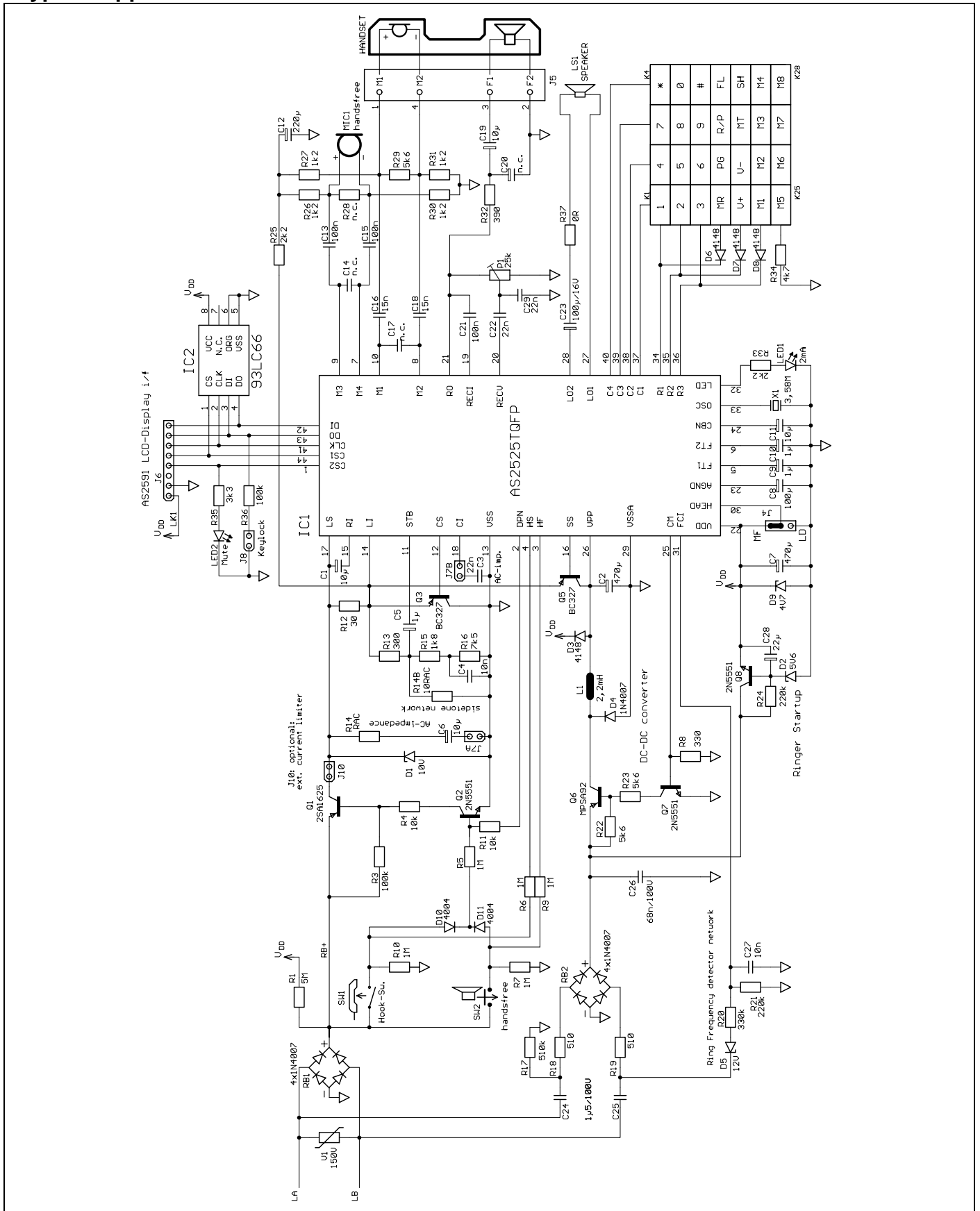

Figure 14: Typical application

Package Outline**44 Pin TQFP**

| |
|-----------------------|
| See Package Catalogue |
|-----------------------|

Devices sold by Austria Mikro Systeme Int. AG are covered by the warranty and patent indemnification provisions appearing in its Term of Sale. Austria Mikro Systeme Int. AG makes no warranty, express, statutory, implied, or by description regarding the information set forth herein or regarding the freedom of the described devices from patent infringement. Austria Mikro Systeme Int. AG reserves the right to change specifications and prices at any time and without notice. Therefore, prior to designing this product into a system, it is necessary to check with Austria Mikro Systeme Int. AG for current information. This product is intended for use in normal commercial applications. Applications requiring extended temperature range, unusual environmental requirements, or high reliability applications, such as military, medical life-support or life-sustaining equipment are specifically *not* recommended without additional processing by Austria Mikro Systeme Int. AG for each application.

Copyright © 1999, Austria Mikro Systeme International AG, Schloss Premstätten, 8141 Unterpremstätten, Austria. Trademarks Registered®. All rights reserved. The material herein may not be reproduced, adapted, merged, translated, stored, or used without the prior written consent of the copyright owner.

Austria Mikro Systeme Int. AG reserves the right to change or discontinue this product without notice.