

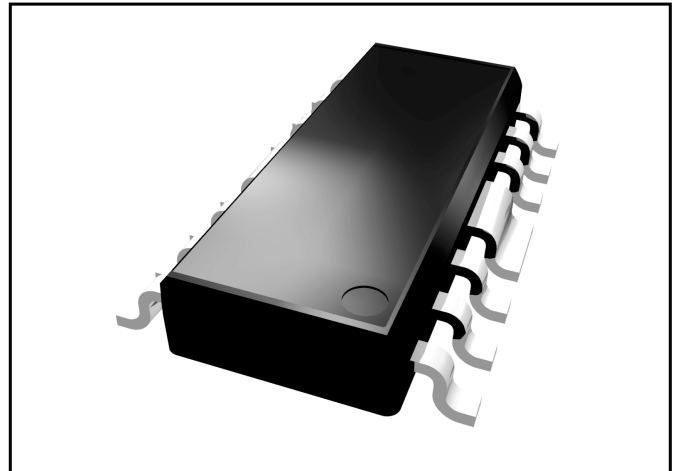

FEATURES

- High Linearity ($IIP_3 + 15 \text{ dBm}$)
- Low Noise Figure (2.0 dB)
- Single Supply (+8Vdc)
- Wide Bandwidth (50 MHz - 1 GHz)



S3C
16 Pin SOIC Package

Description

The ADA10000 is a monolithic IC intended for use in applications requiring high linearity such as: Cellular Telephone Base Station Driver Amplifiers, CATV Fiber Receiver/Distribution Amplifiers and CATV Drop Amplifiers. Supplied in a surface mount, 16 lead-SOIC package, it is well suited for use in amplifiers where small size, reduced component count, and high reliability are important.

PIN	FUNCTION
1	GND
2	GND
3	GND
4	GND
5	GND
6	RF _{IN}
7	GND
8	GND
9	GND
10	GND
11	GND
12	GND
13	GND
14	RF _{OUT}
15	GND
16	GND

External Test Circuit

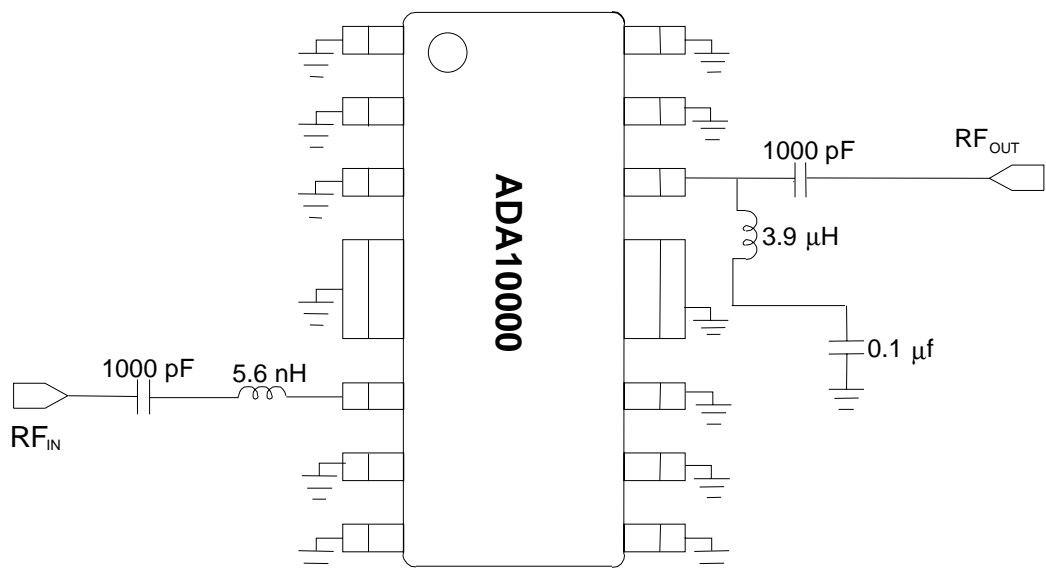

Absolute Maximum Ratings

PARAMETER	MIN	MAX	UNITS
V_{DD}/V_{RFOUT}	0	12	VDC
V_{RFIN}	-	0	VDC
RF_{IN}	-	+10	dBm
Storage Temperature	-65	+150	°C
Soldering Temperature	-	260	°C
Soldering Time	-	5.0	Sec.
Thermal Resistance	-	35	° C/W

Operating Ranges

PARAMETER	MIN	TYP	MAX	UNIT
V_{DD}	4	8 ¹	9	Volts
I_{DD}	50	-	150	mA
Case Temperature	-40	-	85*	°C

* Median time to failure degraded above this temperature

Electrical Specifications

($T_A = +25\text{ °C}$, $RF = 50\text{ to }1000\text{ MHz}$, Test System = 75Ω , $V_{DD} = +8V_{DC}$)

PARAMETER	MIN	TYP	MAX	UNITS
CSO^2/CSO^4	60/62	-	-	dBc
CTB^2/CTB^4	65/74	-	-	dBc
Gain	14	15	-	dB
Noise Figure	-	2.0	3.5	dB
2nd Order Input Intercept Point (IIP2) ³	+29	+34	-	dBm
3rd Order Input Intercept Point (IIP3) ³	+13	+15	-	dBm

1. The device can be operated at +6 V_{DC} for lower power dissipation; Refer to the figures on page for performance variation with supply voltage.
2. 160 channels, +17 dBmV per channel, (measured at the output) 6 MHz channel spacing.
3. Two tones, -10 dBm per tone at input.
4. 80 channels, +19 dBmV per channel @ output, 6 MHz channel spacing.

Gain and Noise Figure vs Frequency
Tc = 25 deg C, VDD = +8V

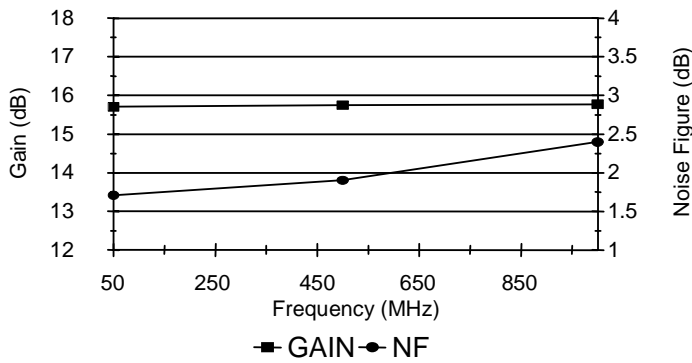

Gain and Noise Figure vs. Vdd
Tc = 25 deg C, RF = 500 MHz

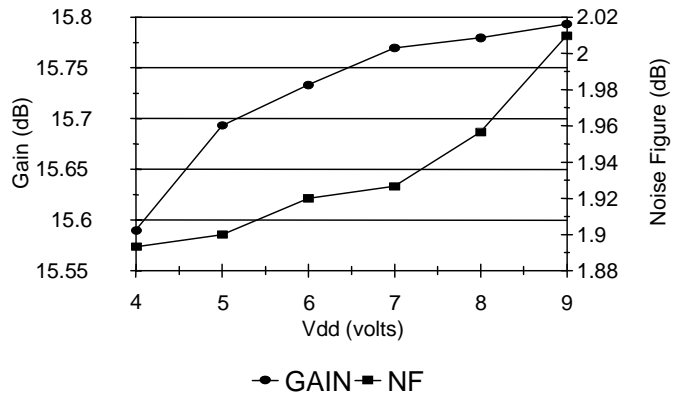

IIP2, IIP3 vs. Vdd
Tc = 25 deg C

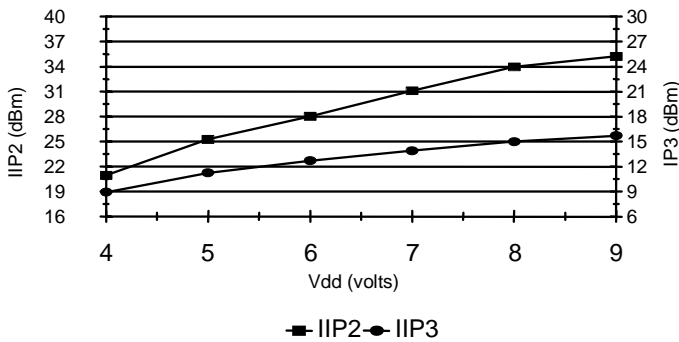

Pin vs. Pout

Tc = 25 deg C, VDD = +8V, RF = 500 MHz

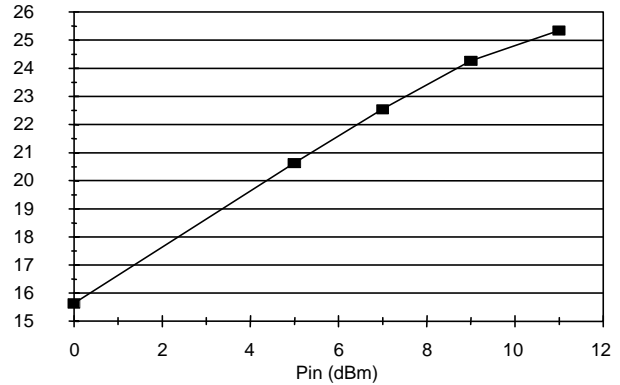

*** Notes:**

IIP 2 Measured at 986.5 MHz, Input = two tones at 55.25 MHz and 931.25 MHz at - 10 dBm
 IIP 3 Measured with two tones at the input,
 R_F = 986.5 MHz and 992.5 MHz at - 10 dBm

INPUT IMPEDANCE

START: 0.050 GHz
STOP: 1.00 GHz

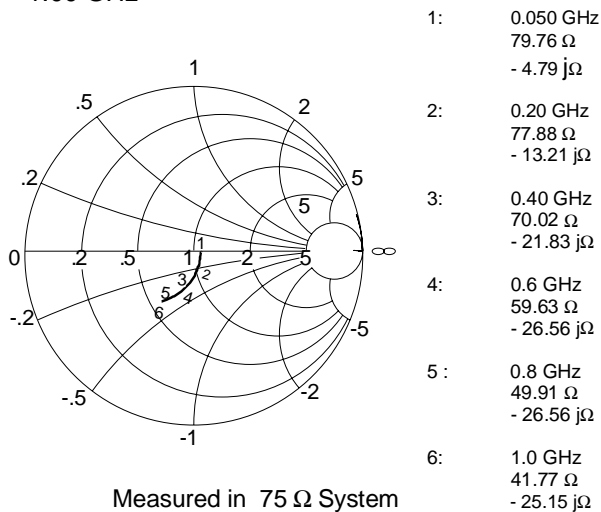

Measured in 75 Ω System

OUTPUT IMPEDANCE

START: 0.050 GHz
STOP: 1.00 GHz

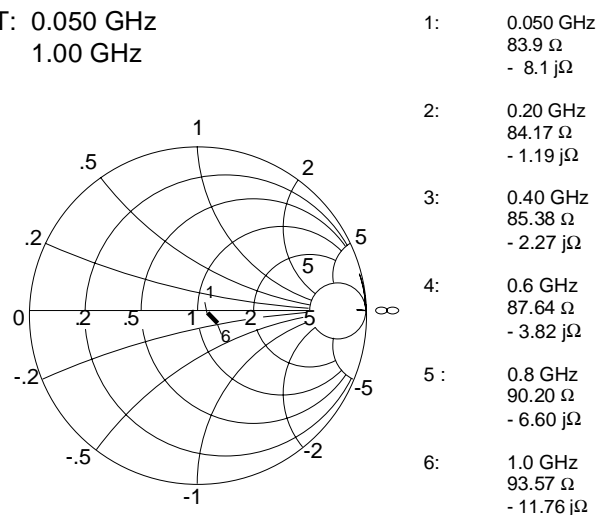

Measured in 75 Ω System

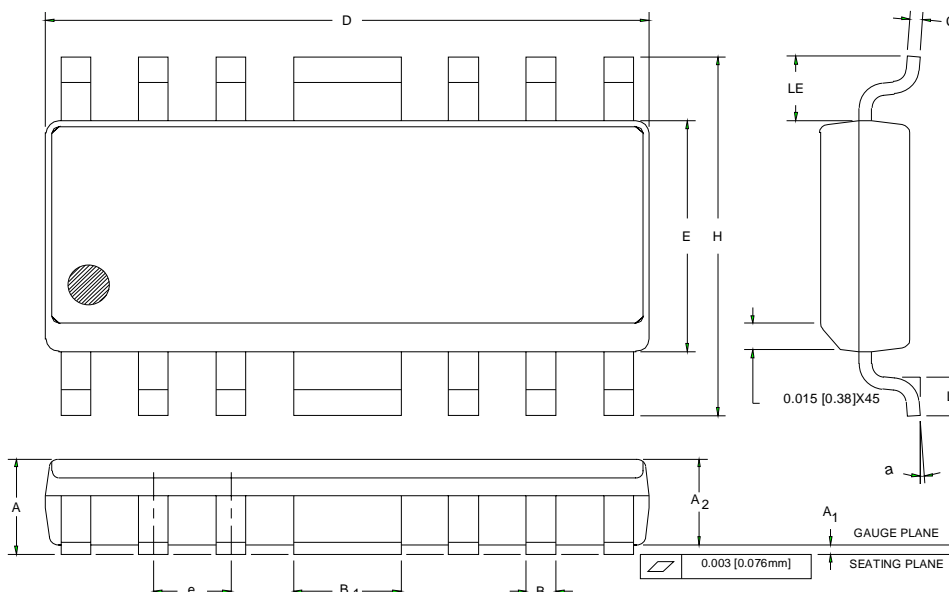

SYMBOL	INCHES		MILLIMETERS		NOTE
	MIN.	MAX.	MIN.	MAX.	
A	0.058	0.068	1.47	1.73	
A ₁	0.004	0.010	0.10	0.25	
A ₂	0.055	0.065	1.40	1.65	
B	0.013	0.020	0.33	0.50	
B ₁	0.062	0.070	1.58	1.78	
C	0.008	0.010	0.20	0.25	4
D	0.380	0.400	9.66	10.16	2
E	0.150	0.160	3.81	4.06	3
e	0.050 BSC		1.27 BSC		
H	0.226	0.244	5.74	6.20	
L	0.016	0.040	0.41	1.02	
LE	0.030	—	0.76	—	
a	0	8	0	8	

- NOTES:
1. CONTROLLING DIMENSION: INCHES
 2. DIMENSION "D" DOES NOT INCLUDE MOLD FLASH, PROTRUSIONS OR GATE BURRS. MOLD FLASH, PROTRUSIONS AND GATE BURRS SHALL NOT EXCEED 0.006 [0.15mm] PER SIDE.
 3. DIMENSION "E" DOES NOT INCLUDE INTER-LEAD FLASH OR PROTRUSIONS. INTER-LEAD FLASH AND PROTRUSIONS SHALL NOT EXCEED 0.010 [0.25mm] PER SIDE.
 4. LEAD THICKNESS AFTER PLATING TO BE 0.013 [0.33mm] MAXIMUM.

SPECIFICATION: 98000-006
 SUBJECT: PUBLISHED OUTLINE,
 16 LEAD BATWING SOIC PKG.



ANADIGICS, Inc.
 35 Technology Drive
 Warren, New Jersey 07059
 Tel: (908) 668-5000
 Fax: (908) 668-5132
<http://www.anadigics.com>
Mktg@anadigics.com

IMPORTANT NOTICE

ANADIGICS, Inc. reserves the right to make changes to its products or discontinue any product at any time without notice. The Advanced Product data sheets and product specifications contained in this data sheet are subject to change prior to a products formal introduction. The information in this data sheet has been carefully checked and is assumed to be reliable. However, ANADIGICS assumes no responsibility for inaccuracies. ANADIGICS strongly urges customers to verify that the information they are using is current before placing orders.

WARNING

ANADIGICS products are not intended for use in life support appliances, devices, or systems. Use of an ANADIGICS product in any such application without written consent is prohibited.