

FEATURES

- 1.25 Gb/s Differential Output TIA
- 5.0V Operation
- Automatic Gain Control
- 75µm 1270-1560nm InGaAs Photodetector
- 1000 MHz Minimum Bandwidth
- -28dBm Typical Sensitivity
- TO-46 Ultra Flat-Window or Lens Package

APPLICATIONS

- Gigabit Ethernet (1.250 Gb/s)
- Fibre channel (1.064 Gb/s)

PRODUCT DESCRIPTION

The ANADIGICS AMT121302, packaged in a TO46 flat window or lens can, is a 5V integrated photodetector and transimpedance amplifier (TIA) used to convert a long wavelength (1270-1560nm) input optical signal into a differential output voltage, and is manufactured in ANADIGICS' 6" GaAs wafer fabrication facility. The TIA maximizes the

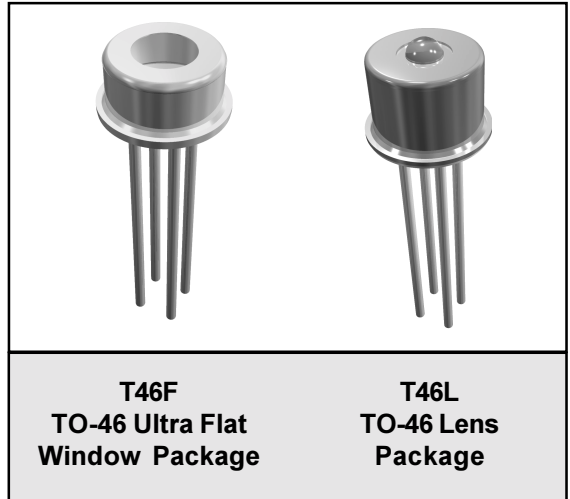

receiver performance by providing a negative voltage to reverse bias the photodetector which allows the device to achieve high sensitivity and wide bandwidth. These products are readily designed into receivers and transceivers for Gigabit Ethernet and Fibre Channel applications.

Figure 1: Block Diagram

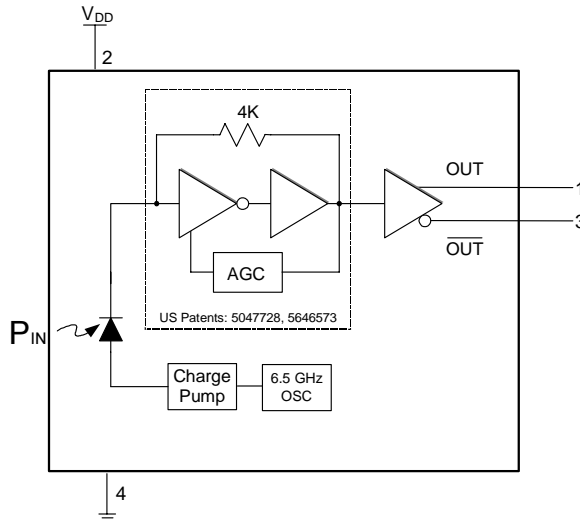

Table 1: Absolute Maximum Ratings

V_{DD}	7.0V
P_{IN}	+5dBm
T_S	Storage Temp. - 65 °C to 125 °C

Table 2: Electrical Characteristics

PARAMETER	MIN	TYP	MAX	UNIT
Wavelength (λ)	1270		1560	nm
Detector Diameter		75		μ m
Small Signal Differential (@ 50 MHz) Responsivity ⁽¹⁾ For T46F Package For T46L Package	2500 2000	3300		V/W
Bandwidth ⁽¹⁾	1000	1100		MHz
Low Frequency Cutoff		800		kHz
Output Resistance	25	40	60	Ω
Output Offset Voltage		2.2		V
Optical Overload ⁽²⁾	-3	0		dBm
Optical Sensitivity ⁽²⁾ For T46F Package For T46L Package	-26 -25	-28		dBm
Differential Output Voltage ^{(3), (4)}		350	600	mV
T_{RISE} & T_{FALL} (20 - 80%) ^{(3), (4)}		160	260	ps
Duty Cycle Distortion ^{(3), (5)}		3	6	%
RMS Jitter ^{(3), (5), (6)}		15	30	ps
Total Jitter (pk-pk) ^{(3), (5), (7)}		90	150	ps
Supply Current		35	50	mA
Operating Voltage Range	+ 4.5	+ 5.0	+ 5.5	V
Operating Ambient Temperature Range	0		70	°C

1. Measured at -17 dBm optical input power with a SMF and output connected into $R_L = 100 \Omega$ (differential).
2. Measured at 10^{-10} BER with a 2^7-1 PRBS, 1.25 Gb/s.
3. Input optical power = -3 dBm, $R_L = 100 \Omega$ (differential).
4. Measured with a 625 MHz, 50% duty cycle square wave.
5. Measured with a 1.25 Gb/s, 2^7-1 PRBS.
6. 1σ about the center eye crossing.
7. 6σ about the center eye crossing.

Table 3: Package PIN Description

Pin	Description	Comment
1	V_{OUT} - TIA Output Voltage (non-Inverted)	Logical '1' with optical input
2	V_{DD} - Positive Supply Voltage	+5 Volts
3	$\overline{V_{OUT}}$ - TIA Output Voltage (Inverted)	Logical '0' with optical input
4	Ground	Case is grounded

Figure 2: Frequency Response *

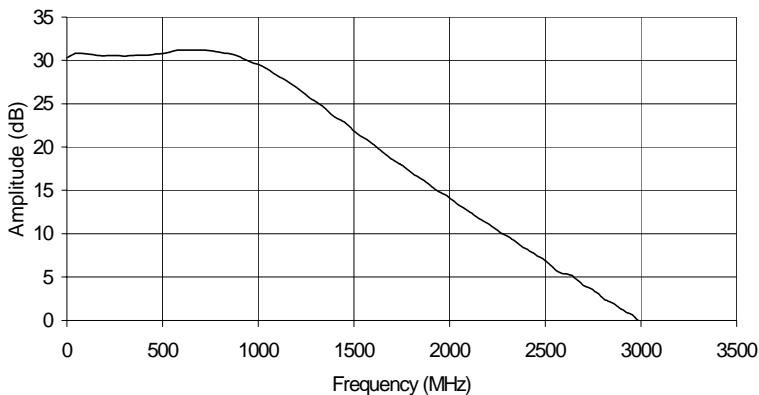

* Calibrated with an optical reference receiver with a gain of 21.62 dB at 50 MHz and a responsivity of 11.77462 A/W.

Figure 3: Eye Diagram with an Optical Input Power of -3.0dBm

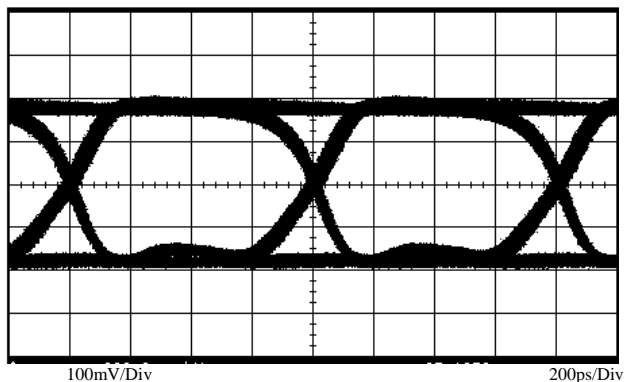

Figure 4: Eye Diagram with an Optical Input Power of -17dBm

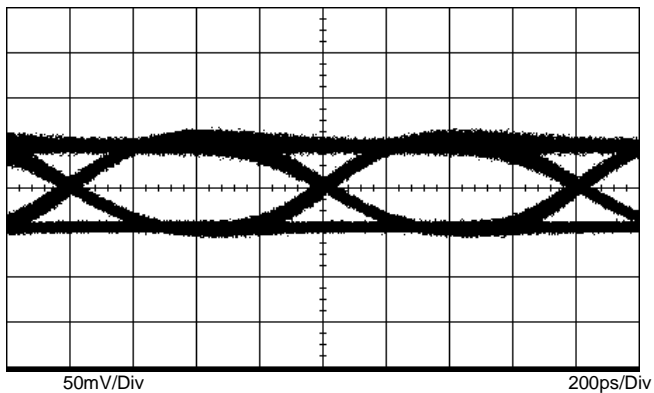

Figure 5: Supply Current vs. Case Temperature

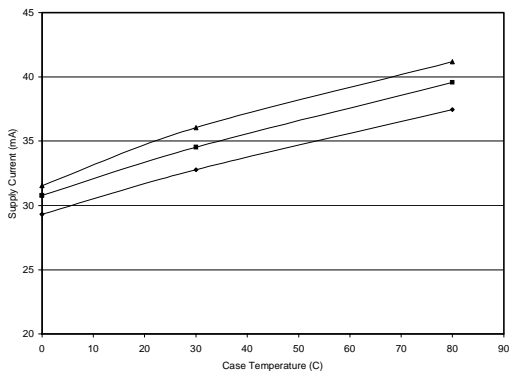

Figure 6: Bandwidth vs. Case Temperature

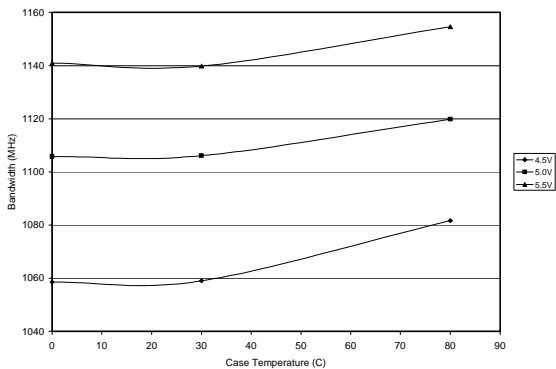

Figure 7: Differential Responsivity vs. Temperature

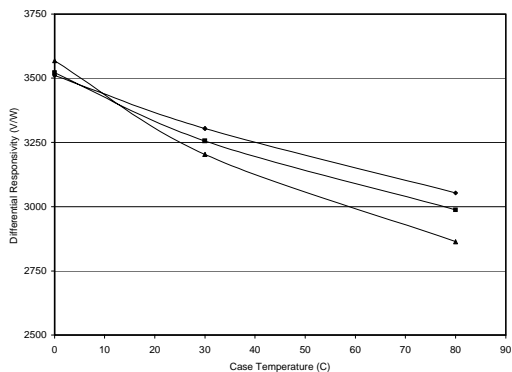

Figure 8: Sensitivity vs. Case Temperature

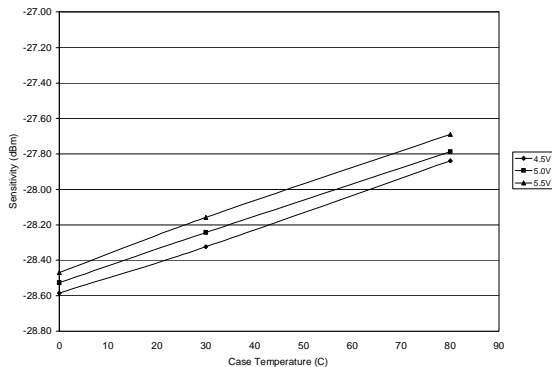

Figure 9: Test Setup for Frequency Response

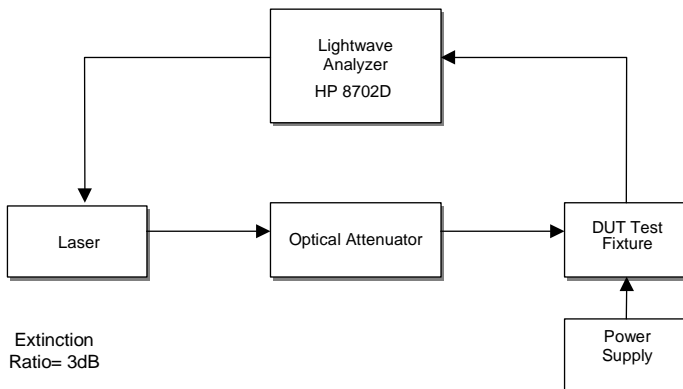

Figure 10: Test Setup for Sensitivity

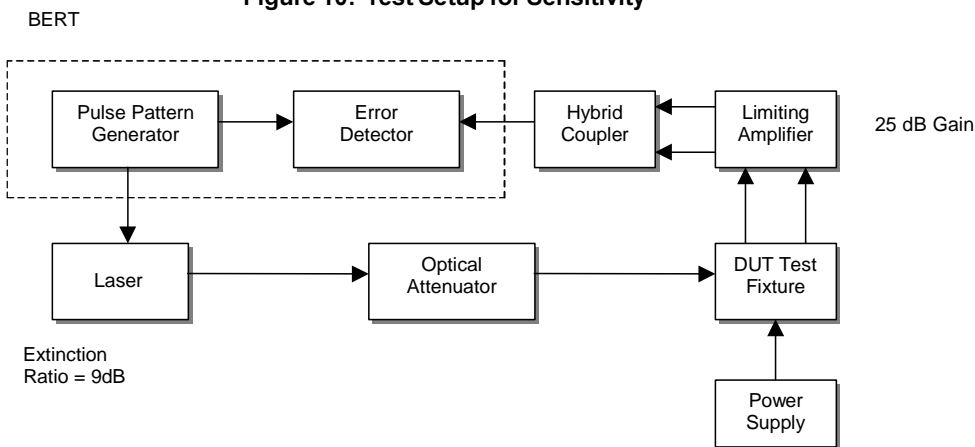

Figure 11: Test Setup for Eye Measurements

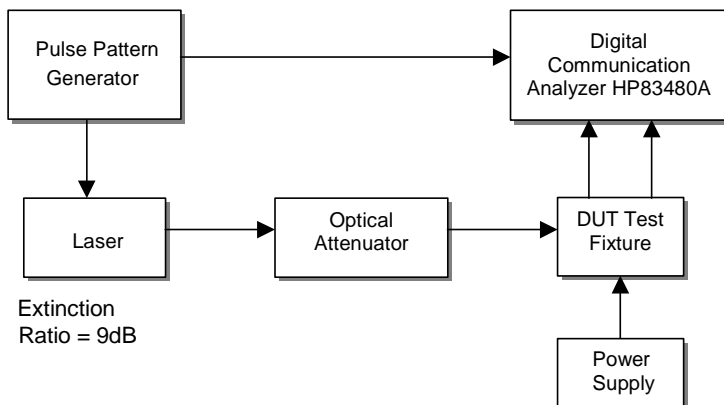

Figure 12: DUT Test Fixture Schematic

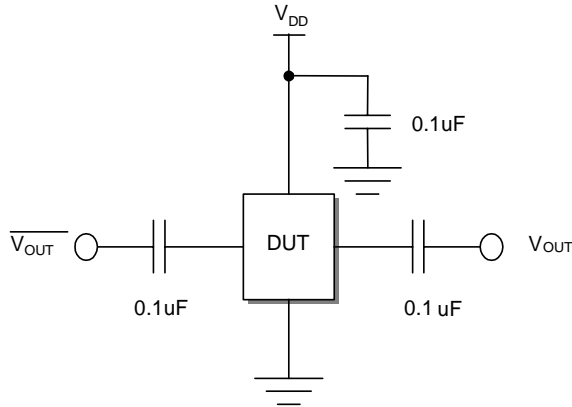
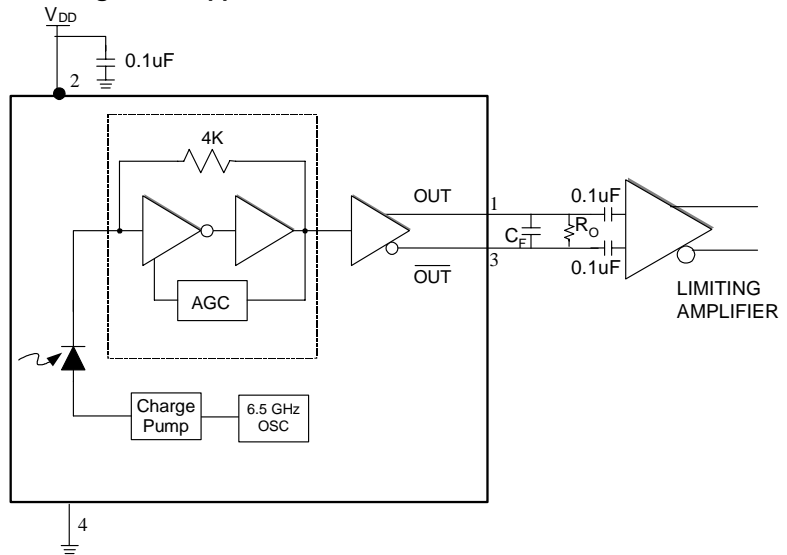

Figure 13: Application Schematic



C_F is an optional single pole noise filter

$$C_F = \frac{1}{2\pi f_c R}$$

f_c is the desired cutoff frequency

$$R = 50 \Omega$$

R_O is required with high input resistance limiting amplifiers

$$R_O = 100 \Omega$$

Figure 14: Evaluation Board Schematic

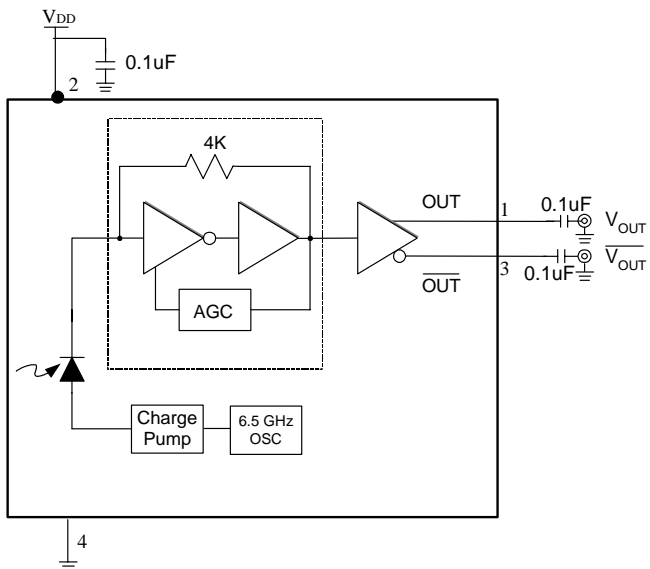

Figure 15: Evaluation Board Layout

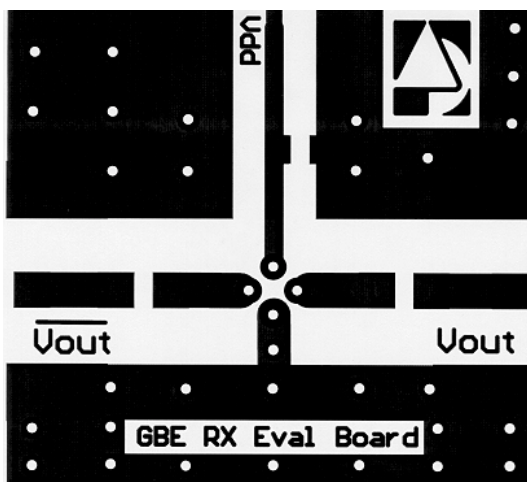
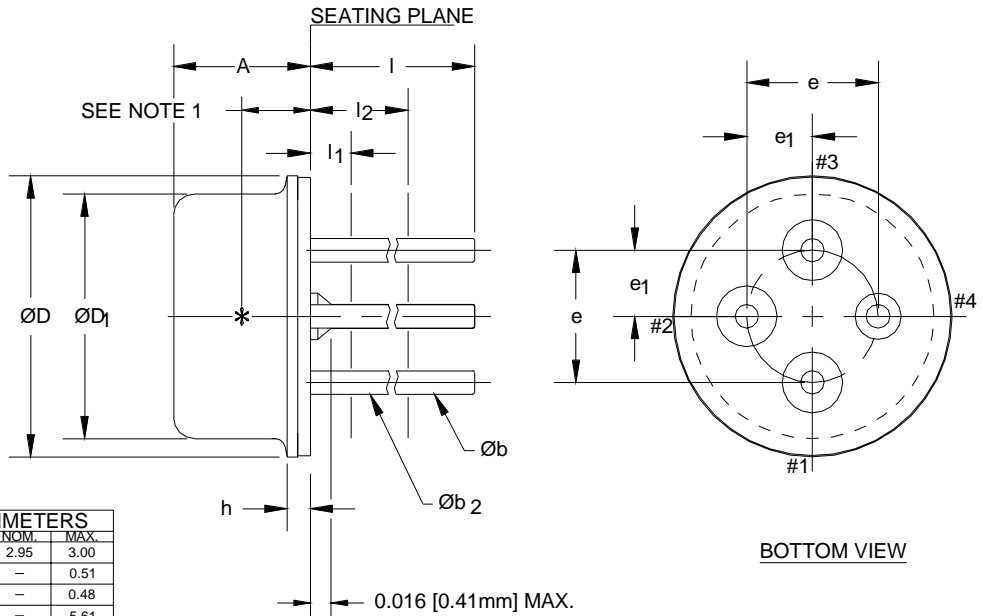

Figure 16: T46F Package Outline Diagram

TO46-1300nm DIFFERENTIAL FLAT WINDOW



Symbol	MILLIMETERS		
	MIN.	NOM.	MAX.
A	2.85	2.95	3.00
Øb	0.41	-	0.51
Øb2	0.30	-	0.48
ØD	5.46	-	5.61
ØD1	4.60	-	4.75
e	2.54 T.P.		
e1	1.27 T.P.		
h	0.36	0.46	0.53
l	12.70	13.20	13.70
l1	-	-	1.27
l2	6.35	-	-

NOTES:

1. INTERNAL OPTICAL HEIGHT = 0.065 ± 0.005 [1.65 ± 0.1]
2. BENT LEADS SHOULD NOT EXTEND OUTSIDE DIAMETER (ØD) OF CAP OR TOUCH EACH OTHER.
3. ALL DIMENSIONS ARE REFERENCE ONLY-EXCEPT A, D & h.

Figure 17: T46L Package Outling Diagram

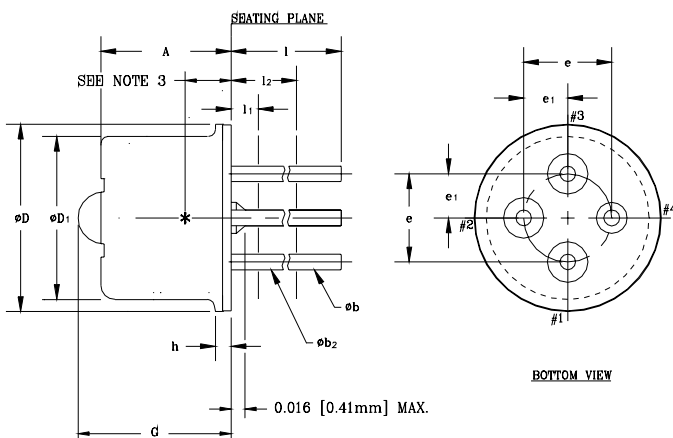

MM CONTROLLING DIMENSIONS

	INCHES		MILLIMETERS		NOTE
	MIN.	MAX.	MIN.	MAX.	
A	--	0.160	--	4.00	
øb	0.016	0.020	0.41	0.51	1
øb2	0.012	0.019	0.30	0.48	1
øD	0.212	0.218	5.38	5.54	
øD1	0.181	0.187	4.60	4.75	
e	0.100	T.P.	2.54	T.P.	2
e1	0.050	T.P.	1.27	T.P.	2
l	0.500	0.540	12.70	13.70	1
l1	--	0.050	--	1.27	1
l2	0.250	--	6.35	--	1
d	--	0.190	--	4.66	7

NOTES:

- (FOUR LEADS) øb2 APPLIES BETWEEN l1 AND l2. øb APPLIES BETWEEN l2 AND 0.5 [12.70mm] FROM SEATING PLANE. DIAMETER IS UNCONTROLLED IN l1 AND BEYOND 0.5 [12.70mm] TO END OF PIN.
- MAXIMUM DIAMETER LEADS AT A GAGING PLANE 0.054 [1.37mm]+0.001 [0.025mm] -0.000 [0.000mm] BELOW SEATING PLANE TO BE WITHIN 0.007 [0.178mm] OF THEIR TRUE POSITION RELATIVE TO MAXIMUM-WIDTH TAB AND TO THE MAXIMUM 0.212 [5.40mm] DIAMETER MEASURED WITH A SUITABLE GAGE. WHEN GAGE IS NOT USED, MEASUREMENT WILL BE MADE AT 0.250 [6.35mm] FROM SEATING PLANE.
- INTERNAL OPTICAL HEIGHT = 0.052±0.003 [1.32±0.08] DIE PLACEMENT ACCURACY FOR REF. ONLY.
- BENT LEADS SHOULD NOT EXTEND OUTSIDE DIAMETER (øD) OF CAP OR TOUCH EACH OTHER.
- ALL DIMENSIONS ARE REFERENCE ONLY-EXCEPT A, D & h.
- DETECTOR DIODE PLACEMENT ACCURACY: ø±0.15MM [0.006] ALL DIRECTIONS
- LENS HEIGHT = 0.65±0.1 [0.026±0.004]

0-022

Ordering Information

Part Number	Package Option	Package Description
AMT121302T46F	TO-46F	Ultra Flat Window Package
AMT121302T46L	TO-46L	Lens Package

Notes



ANADIGICS, Inc.

141 Mount Bethel Road

Warren, New Jersey 07059, U.S.A

Tel: +1 (908) 668-5000

Fax: +1 (908) 668-5132

<http://www.anadigics.com>

Mktg@anadigics.com

IMPORTANT NOTICE

ANADIGICS, Inc. reserves the right to make changes to its products or discontinue any product at any time without notice. The Advanced Product data sheets and product specifications contained in this data sheet are subject to change prior to a products formal introduction. The information in this data sheet has been carefully checked and is assumed to be reliable. However, ANADIGICS assumes no responsibility for inaccuracies. ANADIGICS strongly urges customers to verify that the information they are using is current before placing orders.

WARNING

ANADIGICS products are not intended for use in life support appliances, devices, or systems. Use of an ANADIGICS product in any such application without written consent is prohibited.