

**FEATURES**

- 1.25 Gb/s Differential Output TIA
- 3.3V Operation
- Automatic Gain Control
- 850nm Photodetector with 100  $\mu\text{m}$  x 100  $\mu\text{m}$  Active Area
- Integrated MSM detector & TIA
- TO-46 Ultra Flat Window or Lens Package
- TO-56 Ultra Flat Window Package

**APPLICATIONS**

- Gigabit Ethernet (1.250Gb/s)
- Fibre Channel (1.0625 Gb/s)



**PRODUCT DESCRIPTION**

The ANADIGICS AMT128503 is a 3.3V monolithically integrated Metal-Semiconductor-Metal (MSM) photodetector and transimpedance amplifier (TIA) used to convert an 850nm input optical signal into a differential output voltage, and is manufactured in ANADIGICS' 6" GaAs wafer fabrication facility. The integrated MSM and TIA receiver maximizes the receiver performance by minimizing the photodetector input parasitics to the TIA and

internally biasing the photodetector to achieve high sensitivity, bandwidth and overload performance. As an integrated product the reliability is inherently better than a discrete solution, and both the MSM-TIA integrated circuit and TO46 flat window, TO46 lens and TO56 flat window packaged receiver pass stringent reliability requirements. These products are readily designed into receivers and transceivers for Gigabit Ethernet and Fibre Channel applications.

**Figure 1: AMT128503 Equivalent Circuit**

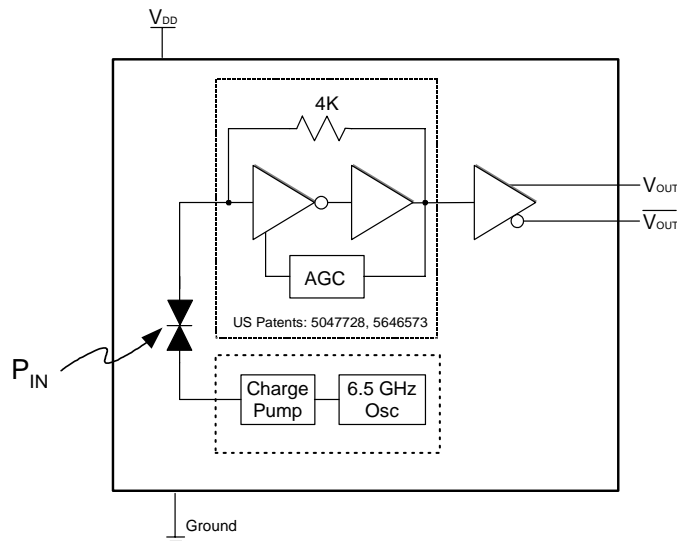

**Table 1: Absolute Maximum Ratings**

$V_{DD}$	6.0 V
$P_{IN}$	+ 5 dBm
$T_S$	Storage Temp. - 65 °C to 125 °C

**Table 2: Electrical Characteristics**

PARAMETER	MIN	TYP	MAX	UNIT
Wavelength ( $\lambda$ )	770	850	860	nm
Detector Active Area		100 x 100		$\mu\text{m}$
Small Signal Differential Responsivity <sup>(1)</sup> (@ 50 MHz)	1000			V / W
Bandwidth <sup>(1)</sup>	1000		1500	MHz
Low Frequency Cutoff		300	1000	kHz
Output Resistance	25	40	60	$\Omega$
Optical Overload <sup>(2)</sup>	0			dBm
Optical Sensitivity <sup>(2)</sup>	-20	- 22		dBm
Differential Output Voltage <sup>(3), (4)</sup>		700		mV
$T_{RISE}$ & $T_{FALL}$ (20 - 80%) <sup>(3), (4)</sup>		260		ps
Duty Cycle Distortion <sup>(3), (5)</sup>		4	10	%
RMS Jitter <sup>(3), (5), (6)</sup>		15		ps
Total Jitter (pk-pk) <sup>(3), (5), (7)</sup>		90		ps
Supply Current			55	mA
Operating Voltage Range	+ 3.0	+3.3	+3.6	V
Operating Ambient Temperature Range	0		70	°C

- (1) Measured at -14 dBm optical input power with output connected into  $R_L = 100\Omega$  (differential)
- (2) Measured at  $10^{-10}$  BER with a 2<sup>7</sup>-1 PRBS at 1.25 GB/s
- (3) Input optical power = -3 dBm,  $R_L = 100\Omega$  (differential).
- (4) Measured with a 625 MHz, 50% duty cycle square wave.
- (5) Measured with a 1.25 Gb/s, 2<sup>7</sup>-1 PRBS.
- (6)  $1\sigma$  about the center eye crossing.
- (7)  $6\sigma$  about the center eye crossing.

**Table 3: Package Pin Description**

PIN	T46F/T46L Description	T56F Description
1	VOUT - TIA Output Voltage (non-inverted) Logical '1' with optical input	VDD - Positive Supply Voltage
2	VDD - Positive Supply Voltage	$\overline{\text{VOUT}}$ - TIA Output Voltage (inverted) Logical "1" with optical input
3	$\overline{\text{VOUT}}$ - TIA Output Voltage (inverted) Logical '0' with optical input	Ground (case is grounded)
4	Ground (case is grounded)	VOUT - TIA Output Voltage (non-inverted) Logical "1" with optical input

Figure 2: Eye Diagram with an Optical Input Power of -17dBm

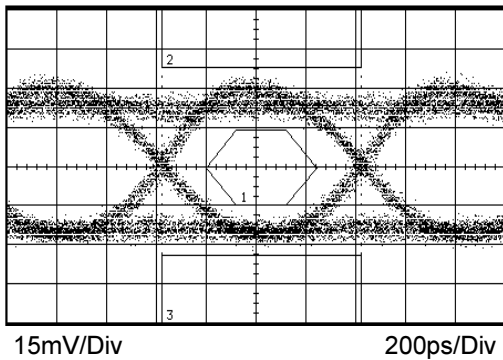

Figure 3: Eye Diagram with an Optical Input Power of -1.0dBm

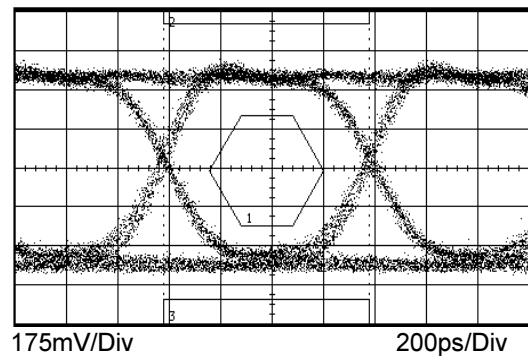

Figure 4: Supply Current vs Temperature

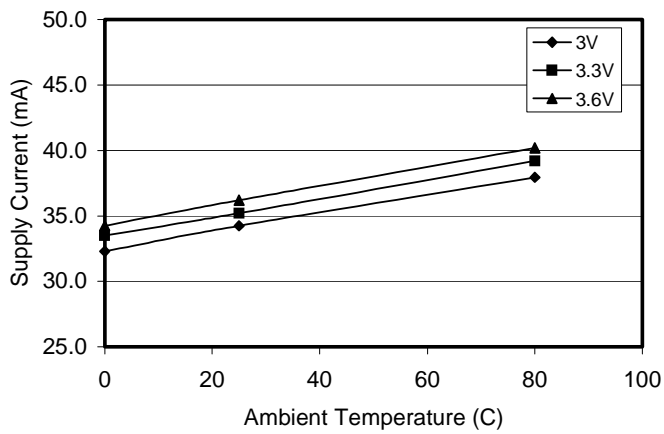

Figure 5: Bandwidth vs. Temperature

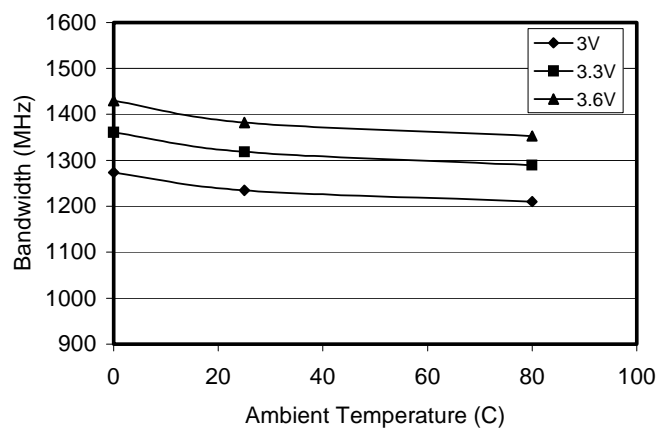

Figure 6: Differential Responsivity vs Temperature

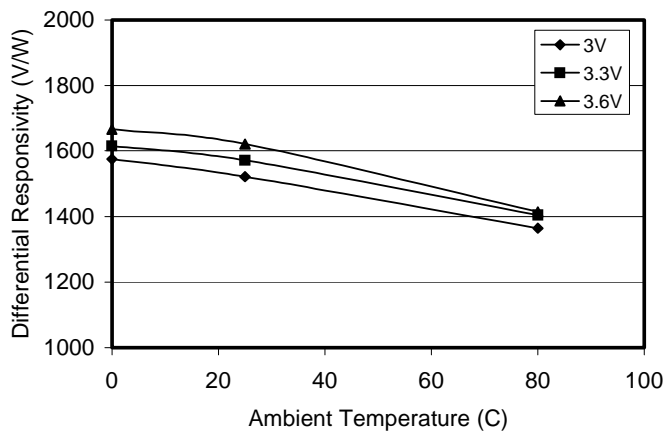
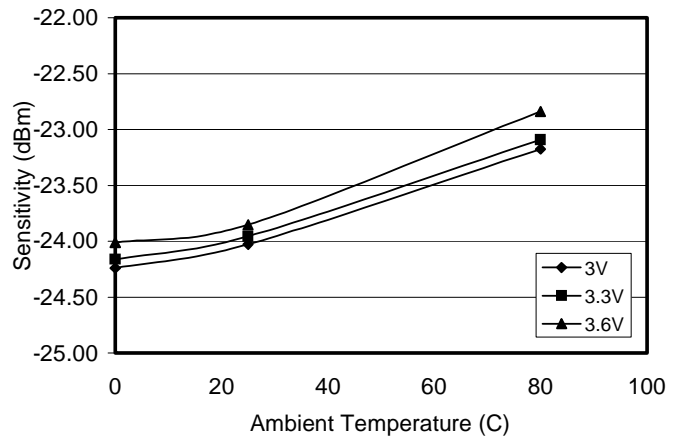
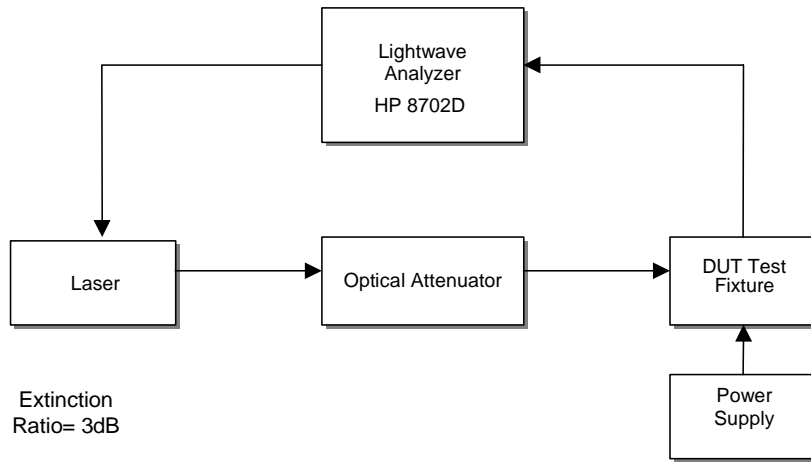

Figure 7: Sensitivity vs Temperature



**Figure 8: Test Setup for Frequency Response**



**Figure 9: Test Setup for Sensitivity**

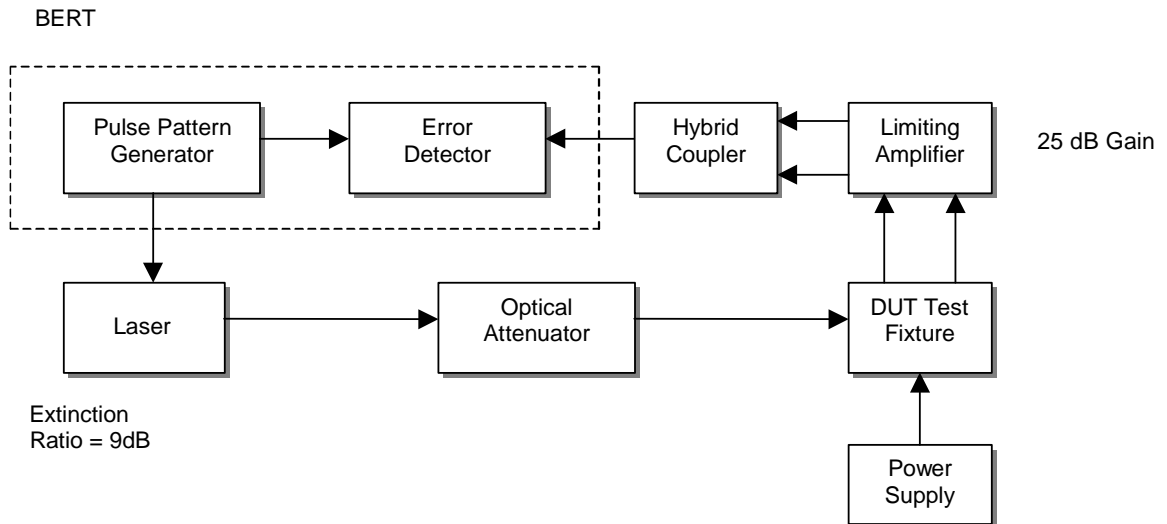

**Figure 10: Test Setup for Eye Measurements**

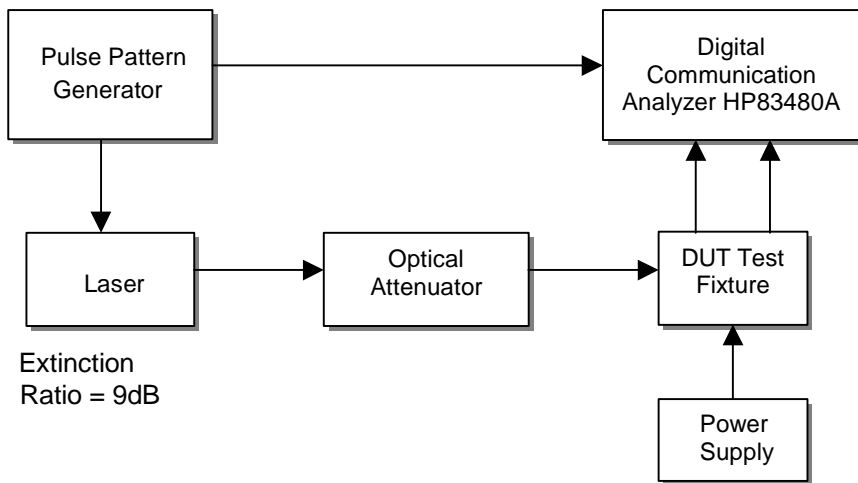

Figure 11: DUT Test Fixture Schematic

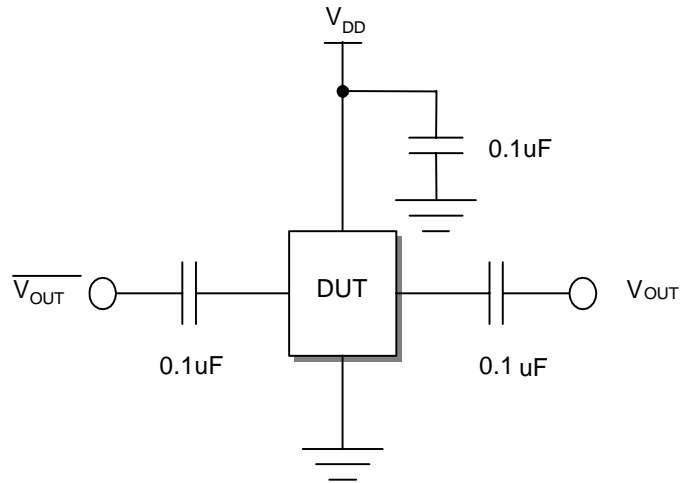
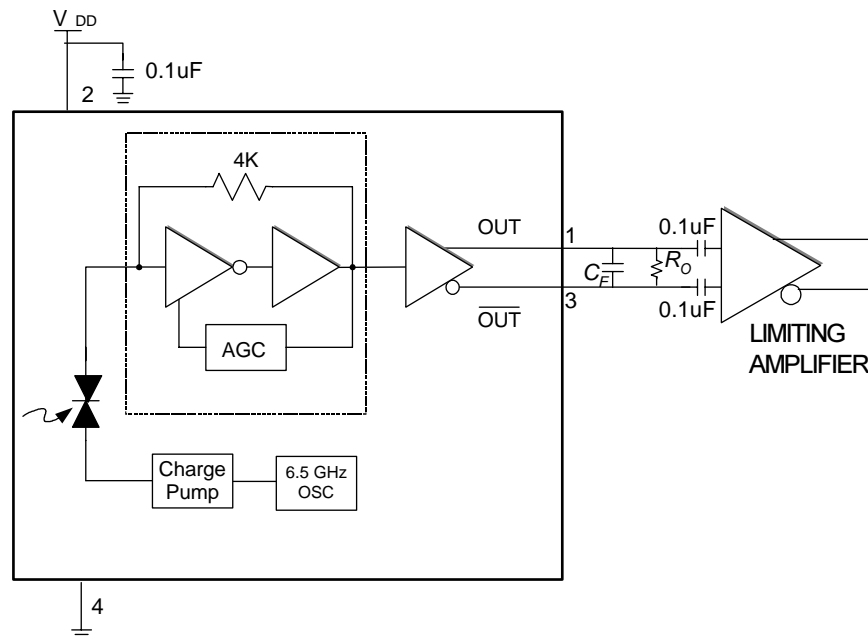

Figure 12: Application Schematic



$C_F$  is an optional single pole noise filter

$$C_F = \frac{1}{2\pi f_c R}$$

$f_c$  is the desired cutoff frequency

$$R = 50 \Omega$$

$R_O$  is required with high input resistance limiting amplifiers

$$R_O = 100 \Omega$$

Figure 13: Evaluation Board Schematic

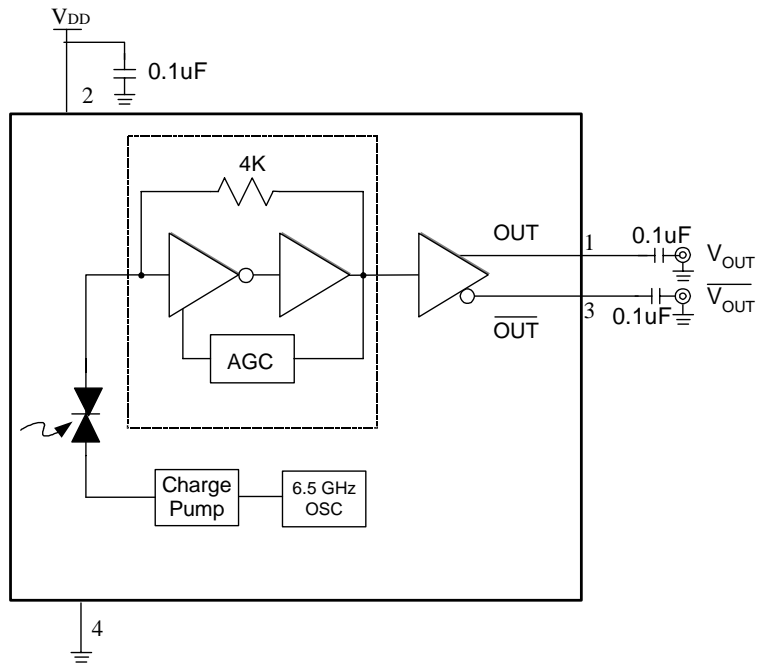

Figure 14: Evaluation Board Layout

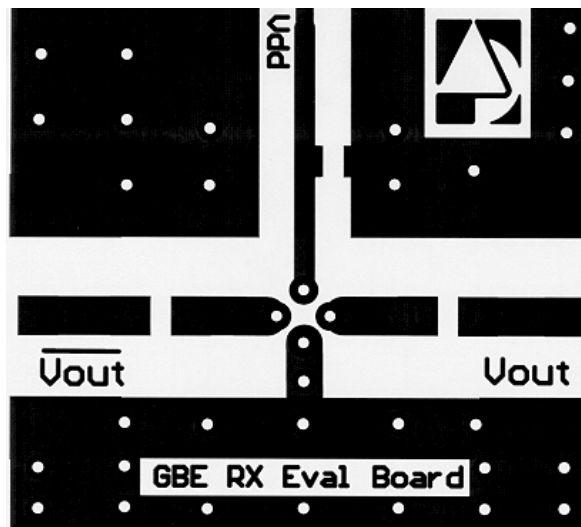
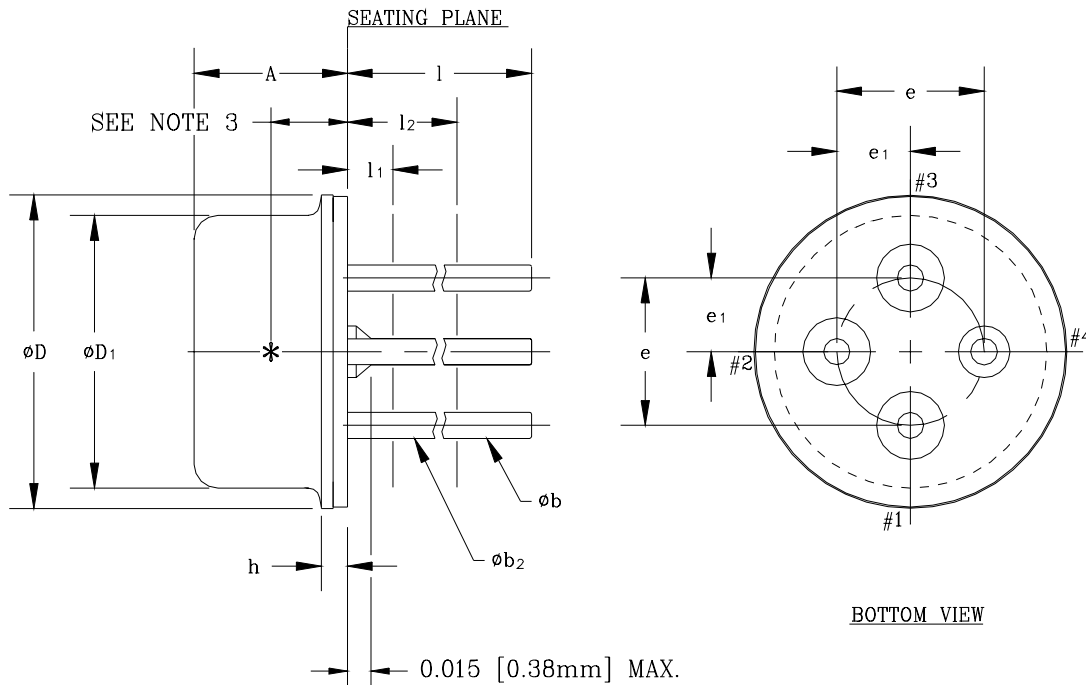

Figure 15: T46F Package Outline Diagram



MM CONTROLLING DIMENSIONS

S <sub>M</sub> B <sub>OL</sub>	INCHES		MILLIMETERS		NOTE
	MIN.	MAX.	MIN.	MAX.	
A	0.098	0.110	2.50	2.80	
øb	0.016	0.020	0.41	0.51	1
øb <sub>2</sub>	0.012	0.019	0.30	0.48	1
øD	0.212	0.218	5.38	5.54	
øD <sub>1</sub>	0.181	0.187	4.60	4.75	
e	0.100 T.P.		2.54 T.P.		2
e <sub>1</sub>	0.050 T.P.		1.27 T.P.		2
h	0.014	0.022	0.36	0.56	
l	0.500	0.540	12.70	13.70	1
l <sub>1</sub>	-	0.050	-	1.27	1
l <sub>2</sub>	0.250	-	6.35	-	1

NOTES:

1. (FOUR LEADS) øb<sub>2</sub> APPLIES BETWEEN l<sub>1</sub> AND l<sub>2</sub>. øb APPLIES BETWEEN l<sub>2</sub> AND 0.5 [12.70mm] FROM SEATING PLANE. DIAMETER IS UNCONTROLLED IN l<sub>1</sub> AND BEYOND 0.5 [12.70mm] TO END OF PIN.
2. MAXIMUM DIAMETER LEADS AT A GAGING PLANE 0.054 [1.37mm]+0.001 [0.025mm] -0.000 [0.000mm] BELOW SEATING PLANE TO BE WITHIN 0.007 [0.178mm] OF THEIR TRUE POSITION RELATIVE TO MAXIMUM-WIDTH TAB AND TO THE MAXIMUM 0.212 [5.40mm] DIAMETER MEASURED WITH A SUITABLE GAGE. WHEN GAGE IS NOT USED, MEASUREMENT WILL BE MADE AT 0.250 [6.35mm] FROM SEATING PLANE.
3. INTERNAL OPTICAL HEIGHT = 0.052±0.003[1.31±.08]
4. BENT LEADS SHOULD NOT EXTEND OUTSIDE DIAMETER (øD) OF CAP OR TOUCH EACH OTHER.
5. ALL DIMENSIONS ARE REFERENCE ONLY-EXCEPT A, D & h.
6. DETECTOR DIODE PLACEMENT ACCURACY: ⊕0.15MM[0.006] WITH RESPECT TO CENTER OF HEADER.(REF.ONLY)

Figure 16: T46L Package Outline Diagram

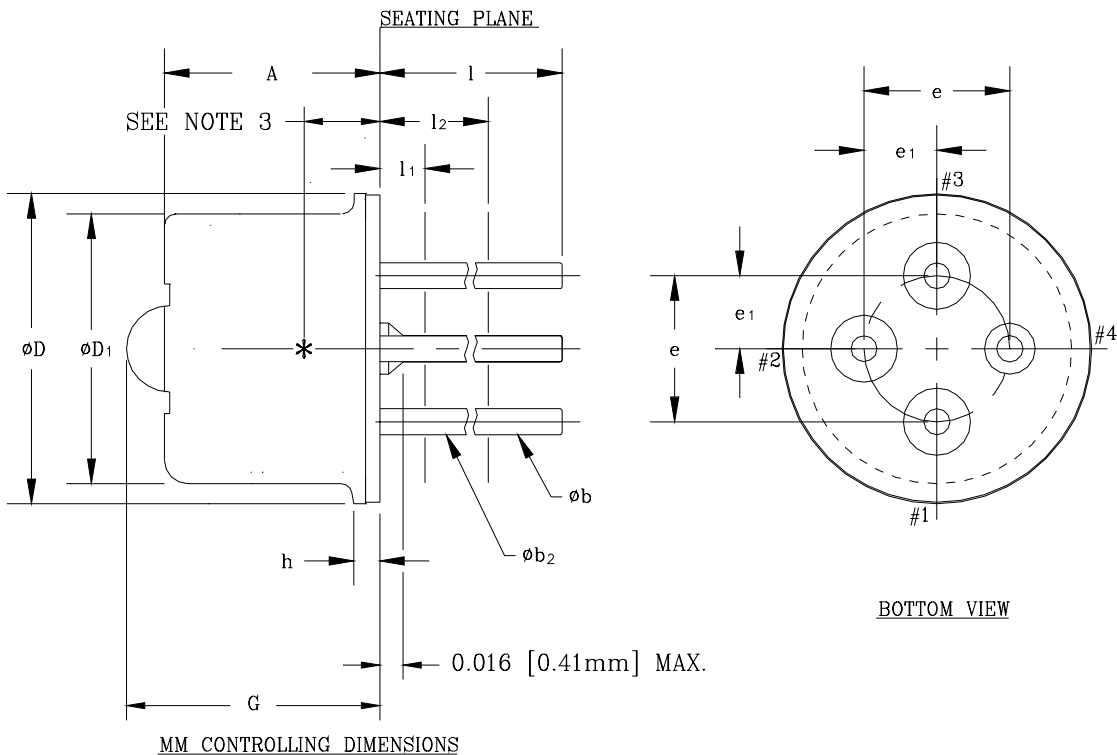

SYMBOL	INCHES		MILLIMETERS		NOTE
	MIN.	MAX.	MIN.	MAX.	
A	--	0.160	--	4.00	
øb	0.016	0.020	0.41	0.51	1
øb2	0.012	0.019	0.30	0.48	1
øD	0.212	0.218	5.38	5.54	
øD1	0.181	0.187	4.60	4.75	
e	0.100 T.P.		2.54 T.P.		2
e1	0.050 T.P.		1.27 T.P.		2
h	0.014	0.022	0.36	0.56	
l	0.500	0.540	12.70	13.70	1
l1	--	0.050	--	1.27	1
l2	0.250	--	6.35	--	1
G	--	0.190	--	4.66	7

**NOTES:**

1. (FOUR LEADS) øb2 APPLIES BETWEEN l1 AND l2. øb APPLIES BETWEEN l2 AND 0.5 [12.70mm] FROM SEATING PLANE. DIAMETER IS UNCONTROLLED IN l1 AND BEYOND 0.5 [12.70mm] TO END OF PIN.
2. MAXIMUM DIAMETER LEADS AT A GAGING PLANE 0.054 [1.37mm]+0.001 [0.025mm] -0.000 [0.000mm] BELOW SEATING PLANE TO BE WITHIN 0.007 [0.178mm] OF THEIR TRUE POSITION RELATIVE TO MAXIMUM-WIDTH TAB AND TO THE MAXIMUM 0.212 [5.40mm] DIAMETER MEASURED WITH A SUITABLE GAGE. WHEN GAGE IS NOT USED, MEASUREMENT WILL BE MADE AT 0.250 [6.35mm] FROM SEATING PLANE.
3. INTERNAL OPTICAL HEIGHT = 0.052±0.003[1.32±0.08] DIE PLACEMENT ACCURACY FOR REF. ONLY.
4. BENT LEADS SHOULD NOT EXTEND OUTSIDE DIAMETER (øD) OF CAP OR TOUCH EACH OTHER.
5. ALL DIMENSIONS ARE REFERENCE ONLY-EXCEPT A, D & h.
6. DETECTOR DIODE PLACEMENT ACCURACY: ±0.15MM[0.006] ALL DIRECTIONS
7. LENS HEIGHT = 0.65±0.1 [0.026±0.004]



Figure 17: T56F Package Outline Diagram

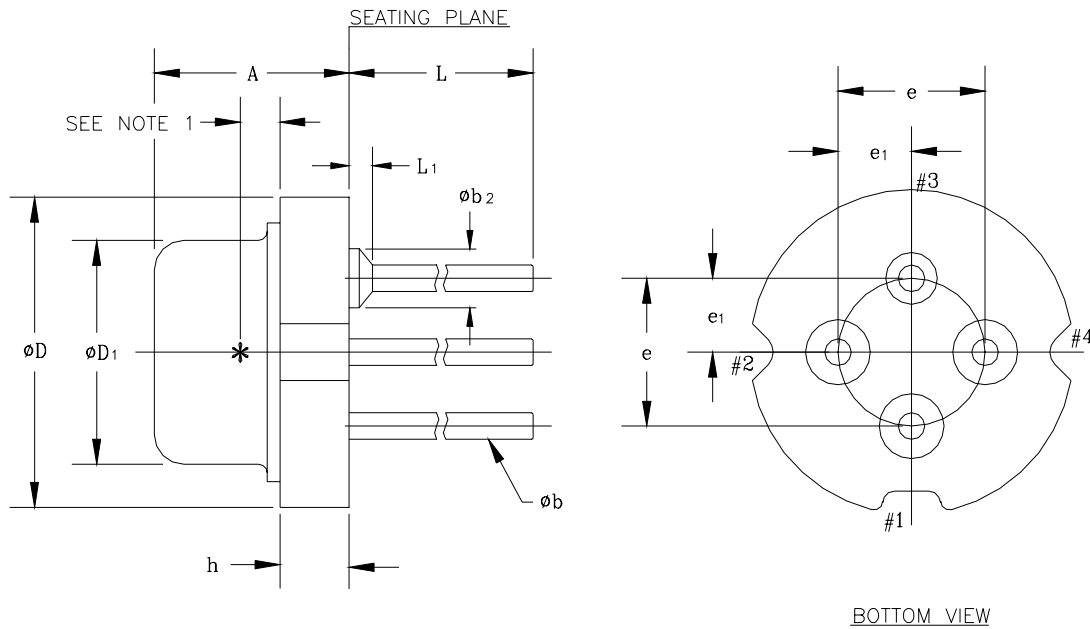

MM CONTROLLING DIMENSIONS

S <sub>MBO</sub> L	MILLIMETERS		INCHES		NOTE
	MIN.	MAX.	MIN.	MAX.	
A	3.10	3.50	0.122	0.138	
øb	0.41	0.48	0.016	0.019	
øb <sub>2</sub>	-	0.89	-	0.035	
øD	5.57	5.60	0.219	0.221	
øD <sub>1</sub>	3.80	3.90	0.150	0.154	
e	2.54 T.P.		0.100 T.P.		
e <sub>1</sub>	1.27 T.P.		0.050 T.P.		
h	1.10	1.30	0.043	0.051	
L	6.00	7.00	0.236	0.276	
L <sub>1</sub>	-	0.38	-	0.015	

NOTES:

1. INTERNAL OPTICAL HEIGHT = 0.70±0.04[0.028±0.0015]
2. BENT LEADS SHOULD NOT EXTEND OUTSIDE DIAMETER (øD) OF CAP OR TOUCH EACH OTHER.
3. ALL DIMENSIONS ARE REFERENCE ONLY, EXCEPT A, øD & h.
4. DETECTOR DIODE PLACEMENT ACCURACY:  $\phi$  0.15MM[0.006] WITH RESPECT TO CENTER OF HEADER: REFERENCE ONLY.
5. CAN PLACEMENT ACCURACY:  $\phi$  0.2MM[0.008] WITH RESPECT TO CENTER OF HEADER: REFERENCE ONLY.

## AMT128503

### Ordering Information

Part Number	Package Option	Package Description
AMT128503T46F	TO-46F	Ultra Flat Window
AMT128503T46L	TO-46L	Lens
AMT128503T56F	TO-56F	Ultra Flat Window

Notes



**ANADIGICS, Inc.**  
141 Mount Bethel Road  
Warren, New Jersey 07059, U.S.A  
Tel: +1 (908) 668-5000  
Fax: +1 (908) 668-5132  
<http://www.anadigics.com>  
[Mktg@anadigics.com](mailto:Mktg@anadigics.com)

**IMPORTANT NOTICE**

ANADIGICS, Inc. reserves the right to make changes to its products or discontinue any product at any time without notice. The Advanced Product data sheets and product specifications contained in this data sheet are subject to change prior to a products formal introduction. The information in this data sheet has been carefully checked and is assumed to be reliable. However, ANADIGICS assumes no responsibility for inaccuracies. ANADIGICS strongly urges customers to verify that the information they are using is current before placing orders.

**WARNING**

ANADIGICS products are not intended for use in life support appliances, devices, or systems. Use of an ANADIGICS product in any such application without written consent is prohibited.