

DUAL INPUT LOW DROPOUT REGULATOR

Features

- Adjustable or Fixed Output
- 520mV typ. Dropout at 5A in dual power voltage mode
- Remote Sense Pin Available
- 2% Accuracy Over Temperature Range
- Build-in Over Temperature Protection
- Build-in Current Limit
- 5 Pin TO-220 and TO-263, TO-252 Packages
- No Supply Sequencing Problems in Dual Supply Mode

Applications

- Microprocessor Supplies
- Chip Set Supplies
- VGA Card Power
- LCD Monitor Power

General Description



The APL1581 series of high performance positive voltage regulators are designed for use in applications requiring very low dropout voltage at 5Amp. The APL1581 can provide a output voltage at the range of 1.25V to 2.55V , where both 5V and 3.3V voltage supplies are available.

The superior dropout characteristics result in reduced heat dissipation compared to regular LDOs. The APL1581 also provides excellent regulation over line , load , and temperature variations.

Current limit is trimmed to ensure specified output current and controlled short-circuit current. On-chip thermal limiting provides protection against any combination of overload that would create excessive junction temperature.

The APL1581 is available in both the through-hole and surface mount versions of the industry standard 5-Pin TO-220 and TO-263, TO-252 power packages.

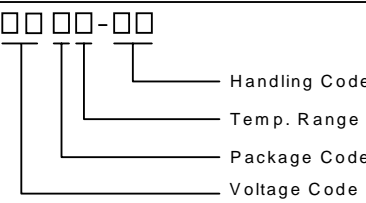
Ordering and Marking Information

<p>APL1581 □□□□-□□</p>  <p>Handling Code</p> <p>Temp. Range</p> <p>Package Code</p> <p>Voltage Code</p>	<p>Package Code F5 : TO-220-5 G5 : TO-263-5 U5 :TO-252-5</p> <p>Temp. Range C : 0 to 70° C</p> <p>Handling Code TU : Tube TR : Tape & Reel</p> <p>Voltage Code : 15 : 1.5V 18 : 1.8V 25 : 2.5V</p>
<p>APL1581F/G/U :  XXXXX - Date Code</p>	<p>APL1581-15 :  XXXXX - Date Code</p>

ANPEC reserves the right to make changes to improve reliability or manufacturability without notice, and advise customers to obtain the latest version of relevant information to verify before placing orders.

Pin Configuration

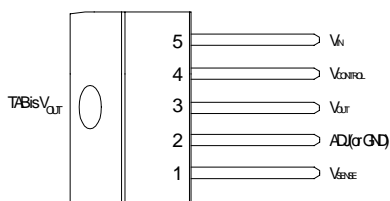

Front View of TO-220-5

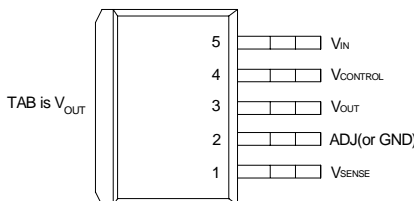

Front View of TO-263-5

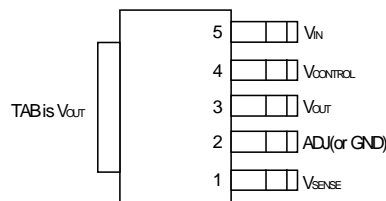

Front View of TO-252-5

Pin Description

PIN		I/O	Description
No.	Name		
1	VSENSE	I	Positive side of the reference voltage, which allows remote sensing to obtain excellent load regulation.
2	ADJ	O	Negative side of the reference voltage, which allows to use resistor divider to set an expect output voltage. A small bypass capacitor can be connected from this pin to ground to improve PSRR performance.
	GND	O	For fixed voltage devices this is the bottom of the resistor divider that sets the output voltage.
3	VOUT	O	Output pin of the regulator, which connects to the TAB. A minimum of 10μF capacitor must be connected from this pin to ground to ensure the stability.
4	VCONTROL	I	Supply pin of the control circuitry, Which must be always higher than VOUT for the device to regulate. (see electrical characteristics)
5	VIN	I	Power input pin of the regulator, which must be always higher than VOUT for the device to regulate. (see electrical characteristics)

Block Diagram

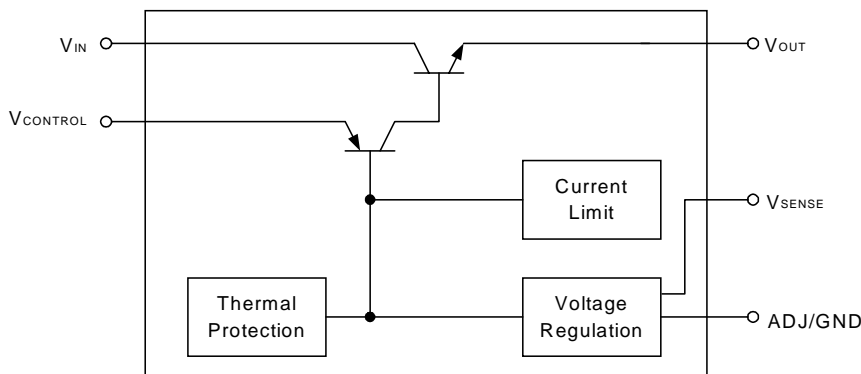

Absolute Maximum Ratings

Symbol	Parameter	Rating	Unit
V _{IN}	Input Voltage	7	V
V _{CONTROL}	Control Voltage	13.2	V
Q _{JA}	Thermal Resistance – Junction to Ambient	62.5	°C/W
P _D	Power Dissipation	Internally Limited	W
T _J	Operating Junction Temperature		°C
	Control Section	0 to 125	
	Power Transistor	0 to 150	
T _{STG}	Storage Temperature Range	-65 to +150	°C
T _L	Lead Temperature (Soldering, 10 second)	260	°C

Electrical Characteristics

Unless otherwise noted, these specifications apply over C_{IN}=10uF, C_{CONTROL}=1uF, C_{OUT}=10uF, and T_J=0 to 125°C. Typical values refer to T_J=25°C. V_{OUT}=V_{SENSE}.

Symbol	Parameter	Test Conditions	APL1581			UNIT
			MIN	TYP	MAX	
V _{REF}	Reference Voltage APL1581	V _{CONTROL} =2.75~12V, V _{IN} =2.05~5.5V, I _O =10mA~5A, V _{ADJ} =0V	1.225	1.250	1.275	V
V _{OUT}	Output Voltage APL1581-15 APL1581-18 APL1581-25	(I _O =0~5A for fixed versions) V _{CONTROL} =3~12V, V _{IN} =2.3~5.5V V _{CONTROL} =3.3~12V, V _{IN} =2.6~5.5V V _{CONTROL} =4~12V, V _{IN} =3.3~5.5V	1.470 1.764 2.450	1.500 1.800 2.500	1.530 1.836 2.550	V
REG _{LINE}	Line Regulation APL1581 APL1581-15 APL1581-18 APL1581-25	(I _O =0A for fixed versions) V _{CONTROL} =2.75~12V, V _{IN} =1.75~5.5V, I _O =10mA, V _{ADJ} =0V V _{CONTROL} =3~12V, V _{IN} =2.3~5.5V V _{CONTROL} =3.3~12V, V _{IN} =2.6~5.5V V _{CONTROL} =4~12V, V _{IN} =3~5.5V			3	mV
REG _{LOAD}	Load Regulation (note 1) APL1581 APL1581-15 APL1581-18 APL1581-25	(I _O =0~5A for fixed versions) V _{CONTROL} =2.75V, V _{IN} =2.1V, V _{ADJ} =0V, I _O =10mA~5A V _{CONTROL} =3V, V _{IN} =2.35V V _{CONTROL} =3.3V, V _{IN} =2.65V V _{CONTROL} =4V, V _{IN} =3.35V			5	mV
V _{CONTROL} -V _{OUT}	Dropout Voltage (note 2) APL1581 APL1581-15 APL1581-18 APL1581-25	I _O =5A for all versions V _{IN} =2.05V, V _{ADJ} =0V V _{IN} =2.3V V _{IN} =2.6V V _{IN} =3.3V		1.20	1.35	V
V _{IN} -V _{OUT}	Dropout Voltage (note 2) APL1581 APL1581-15 APL1581-18 APL1581-25	I _O =5A for all versions V _{CONTROL} =2.75V, V _{ADJ} =0V V _{CONTROL} =3V V _{CONTROL} =3.3V V _{CONTROL} =4V		0.52	0.75	V
I _{LIMIT}	Current Limit	V _{CONTROL} -V _{OUT} =1.5V, V _{IN} -V _{OUT} =0.6V	5			A
I _{LMIN}	Minimum Load Current (note 3) APL1581	V _{CONTROL} =5V, V _{IN} =3.3V, V _{ADJ} =0V		0.8	10	mA
REG _{THERMAL}	Thermal Regulation	30mS Pulse		0.01		%/W

Electrical Characteristics Cont.

Unless otherwise noted, these specifications apply over $C_{IN}=10\mu F$, $C_{CONTROL}=1\mu F$, $C_{OUT}=10\mu F$, and $T_J=0$ to $125^\circ C$. Typical values refer to $T_J=25^\circ C$. $V_{OUT}=V_{SENSE}$.

Symbol	Parameter	Test Conditions	APL1581			UNIT
			MIN	TYP	MAX	
PSRR	Power Supply Ripple Rejection	$V_{RIPPLE}=1V_{PP}$ at 120Hz, $I_O=5A$				dB
		APL1581 $V_{CONTROL}=5V$, $V_{IN}=5V$, $V_{ADJ}=0V$	60	70		
		APL1581-15 $V_{CONTROL}=5.25V$, $V_{IN}=5.25V$				
		APL1581-18 $V_{CONTROL}=5.55V$, $V_{IN}=5.55V$				
$I_{CONTROL}$	Control Pin Current	$V_{CONTROL}-V_{OUT}=1.5V$, $V_{IN}-V_{OUT}=0.8V$, $I_O=5A$		45	120	mA
I_{GND}	Ground Pin Current	APL1581-15 $V_{CONTROL}=3V$, $V_{IN}=2.3V$		8	13	mA
		APL1581-18 $V_{CONTROL}=3.3V$, $V_{IN}=2.6V$				
		APL1581-25 $V_{CONTROL}=4V$, $V_{IN}=3.3V$				
I_{ADJ}	Adjust Pin Current	APL1581 $V_{CONTROL}=2.75V$, $V_{IN}=2.05V$, $V_{ADJ}=0V$		50	120	μA
Q_{JC}	Junction-to-Case Thermal Resistance	Power Transistor			3.0	$^\circ C/W$

Note 1 : Low duty cycle pulse test with Kelvin connections are required to maintain data accuracy .

Note 2 : Dropout voltage is defined as the minimum difference between V_{IN} and V_{OUT} required to maintain 1% V_{OUT} regulation .

Note 3 : Minimum load current is defined as the minimum current required at the output to maintain V_{OUT} regulation.

Application Circuit

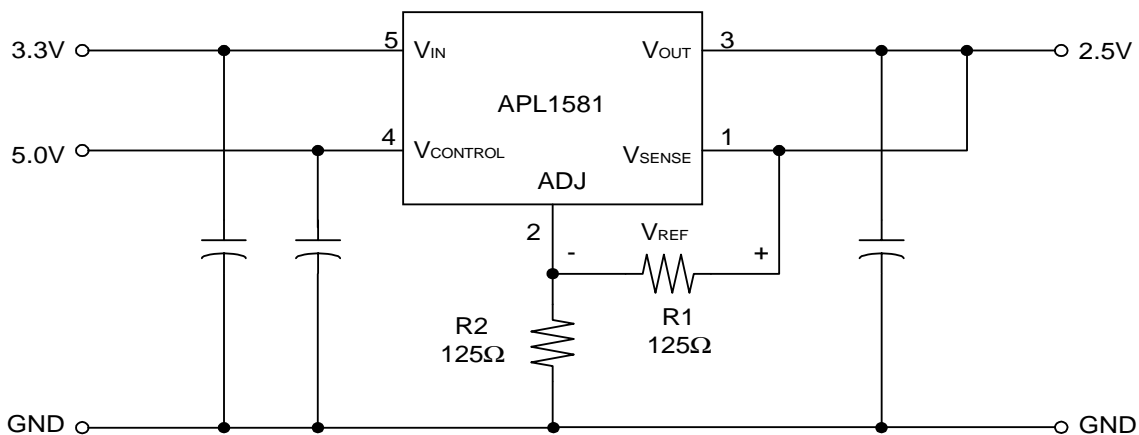

$$* V_{OUT} = V_{REF} (1 + R2 / R1) + I_{ADJ} * R2$$

* $R1$ is typically in range of 100Ω to 125Ω to satisfy the minimum load current requirement

Application Circuit

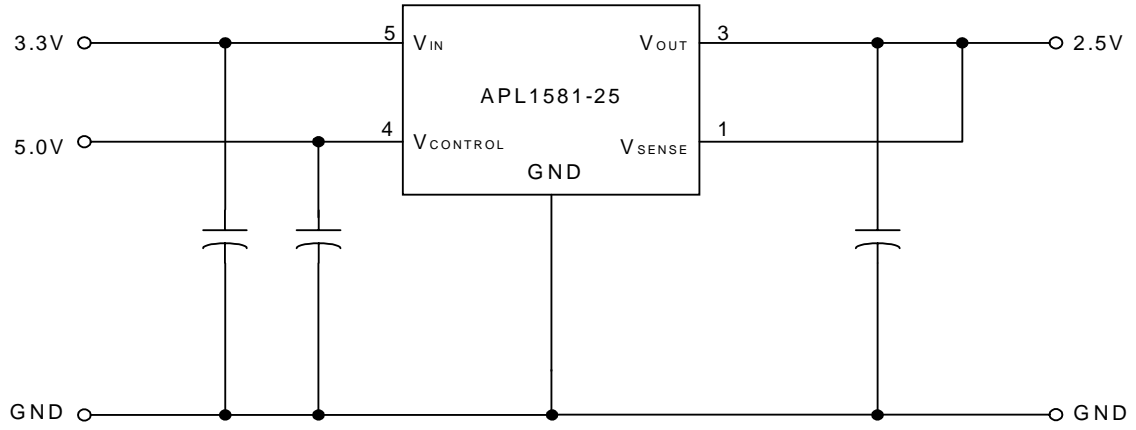

Typical Characteristics

Reference Voltage vs Junction Temperature

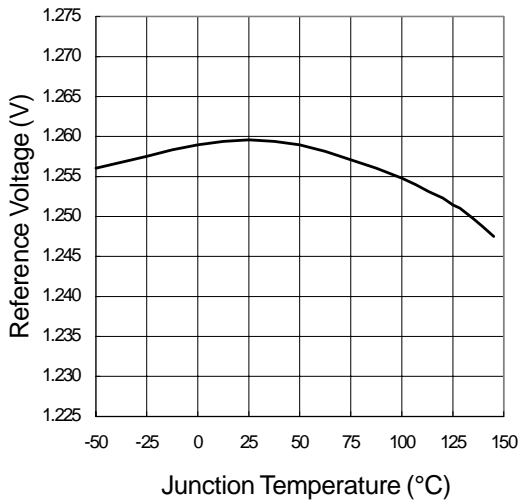

Adjust Pin Current vs Junction Temperature

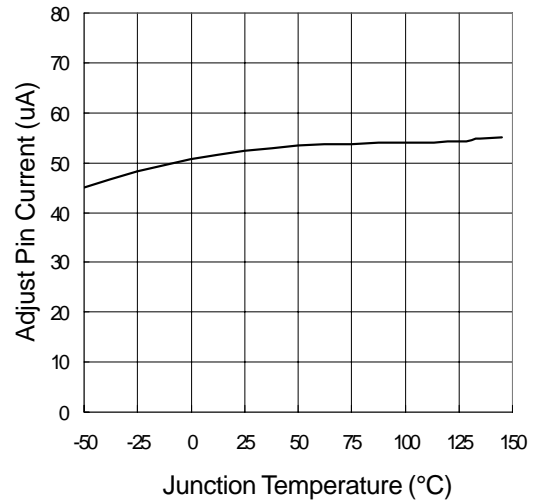

Minimum Load Current vs Junction Temperature

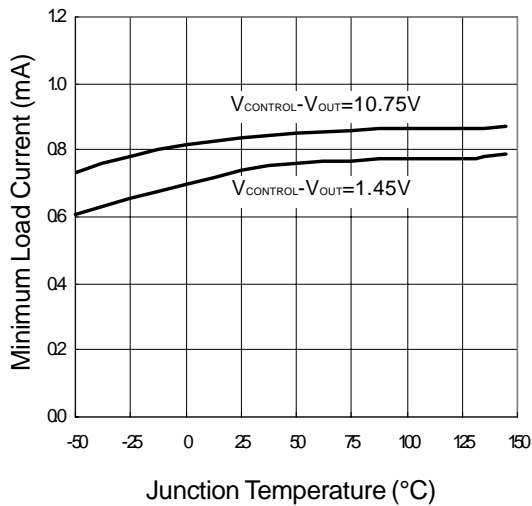

$V_{IN}-V_{OUT}$ Dropout Voltage vs Output Current

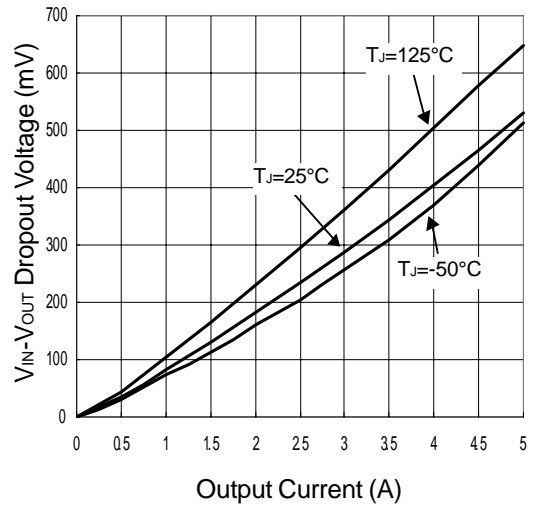

Typical Characteristics

Short-Circuit Current vs Junction Temperature

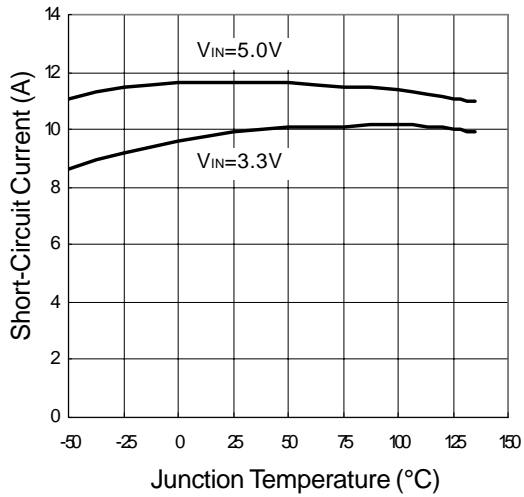

$V_{CONTROL}-V_{OUT}$ Dropout Voltage vs Output Current

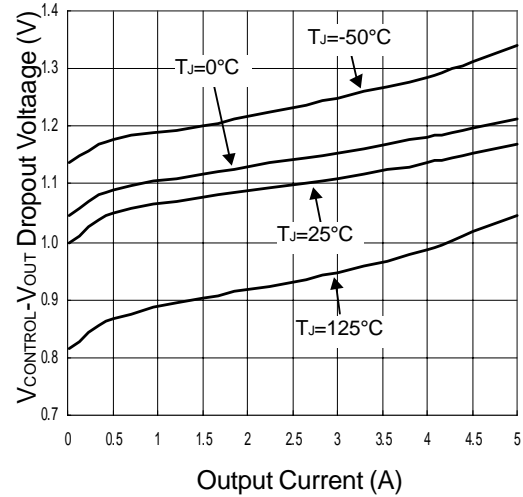

Control Pin Current vs Output Current

$V_{IN}-V_{OUT}=0.6V$

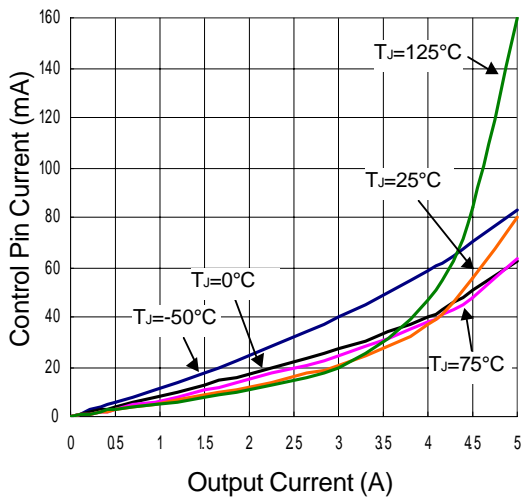

Control Pin Current vs Output Current

$V_{IN}-V_{OUT}=0.8V$

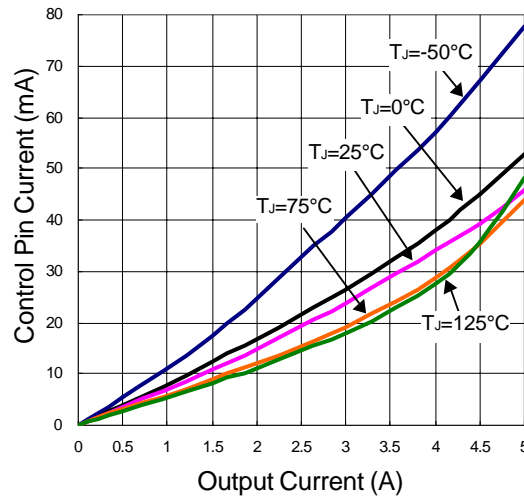

Typical Characteristics

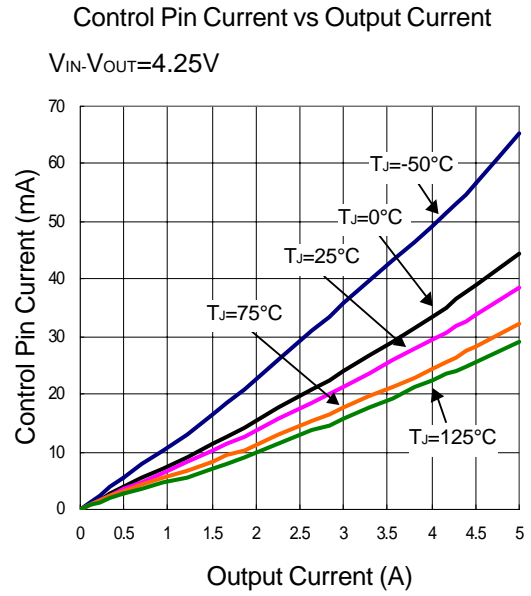
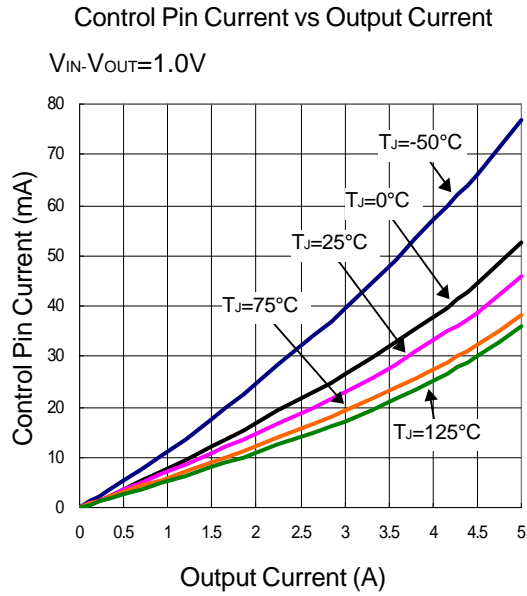

Package Information

TO-220-5

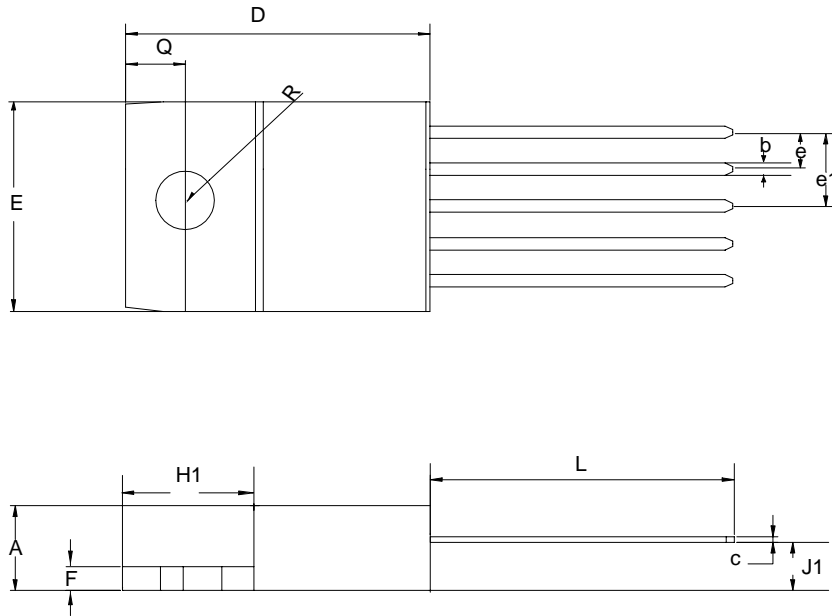

Dim	Millimeters		Inches	
	Min.	Max.	Min.	Max.
A	3.55	4.83	1.140	0.190
b	0.63	1.02	0.025	0.040
c	0.35	0.56	0.014	0.022
D	14.22	16.51	0.560	0.650
e	1.57	1.83	0.062	0.072
e1	6.68	6.94	0.263	0.273
E	9.65	10.67	0.380	0.420
F	1.14	1.40	0.045	0.055
H1	5.84	6.60	0.230	0.260
J1	2.03	3.05	0.080	0.120
L	13.72	14.22	0.540	0.560
R	3.53	4.09	0.139	0.161
Q	2.54	3.43	0.100	0.135

Package Information

TO-263-5

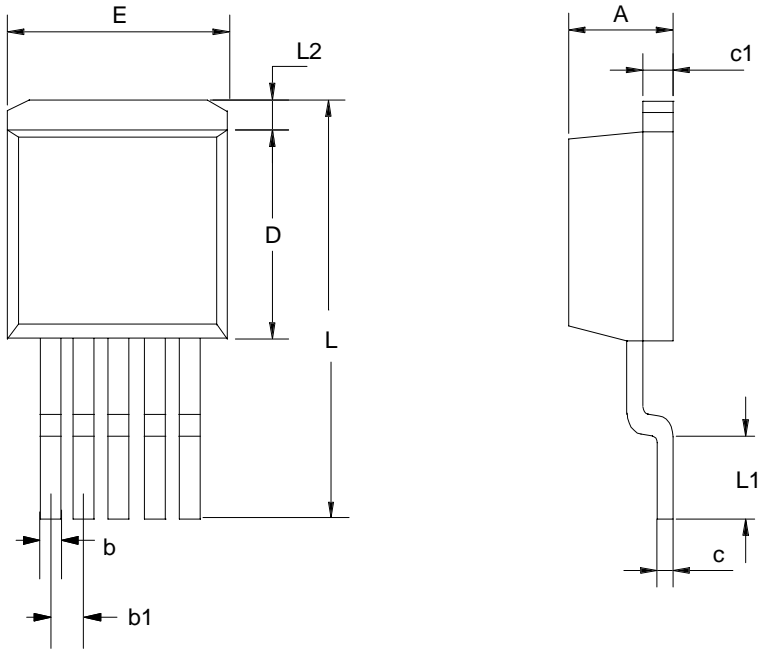

Dim	Millimeters		Inches	
	Min.	Max.	Min.	Max.
A	4.06	4.83	0.160	0.190
b	0.50	0.99	0.020	0.039
b1	1.52	1.83	0.060	0.072
c	0.457	0.736	0.018	0.029
c1	1.14	1.40	0.045	0.055
D	8.25	9.66	0.325	0.380
E	9.65	10.29	0.380	0.405
L	14.60	15.88	0.575	0.625
L1	2.28	2.80	0.090	0.110
L2		1.40		0.055

Packaging Information

TO-252-5

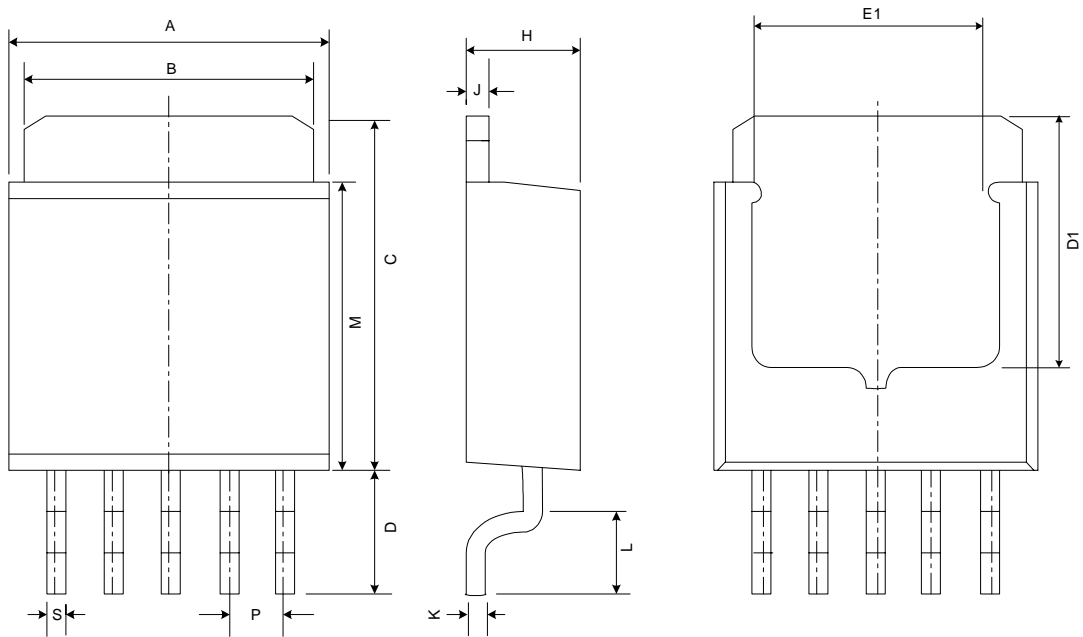

Dim	Millimeters		Inches	
	Min.	Max.	Min.	Max.
A	6.40	6.80	0.25	0.26
B	5.20	5.50	0.20	0.21
C	6.80	7.20	0.26	0.27
D	2.20	2.80	0.08	0.11
D1	5.2REF		0.205REF	
E1	5.3REF		0.209REF	
P	1.27REF		0.05REF	
S	0.50	0.80	0.02	0.03
H	2.20	2.40	0.08	0.09
J	0.45	0.55	0.01	0.02
K	0.45	0.60	0.018	0.024
L	0.90	1.50	0.03	0.06
M	5.40	5.80	0.21	0.22

Physical Specifications

Terminal Material	Solder-Plated Copper (Solder Material : 90/10 or 63/37 SnPb).
Lead Solderability	Meets EIA Specification RSI86-91, ANSI/J-STD-002 Category 3.

Reflow Condition (IR/Convection or VPR Reflow)

Reference JEDEC Standard J-STD-020A APRIL 1999

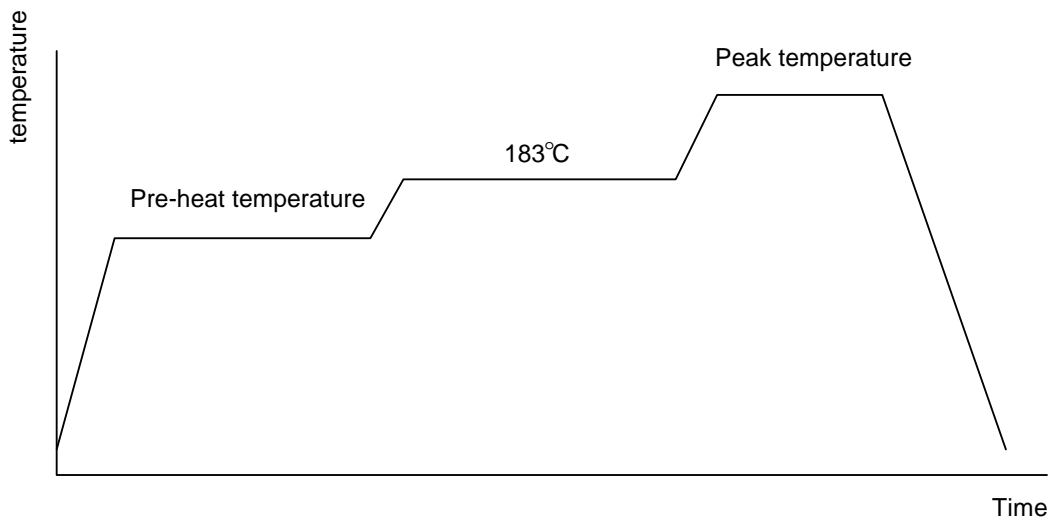

Classification Reflow Profiles

	Convection or IR/ Convection	VPR
Average ramp-up rate(183 °C to Peak)	3°C/second max.	10 °C /second max.
Preheat temperature 125 ± 25 °C)	120 seconds max.	
Temperature maintained above 183 °C	60 ~ 150 seconds	
Time within 5 °C of actual peak temperature	10 ~ 20 seconds	60 seconds
Peak temperature range	220 +5/-0 °C or 235 +5/-0 °C	215~ 219 °C or 235 +5/-0 °C
Ramp-down rate	6°C /second max.	10 °C /second max.
Time 25 °C to peak temperature	6 minutes max.	

pkg. thickness ≥ 2.5mm and all bags	pkg. thickness < 2.5mm and pkg. volume ≥ 350 mm	pkg. thickness < 2.5mm and pkg. volume <
Convection 220 +5/-0 °C		Convection 235 +5/-0 °C
VPR 215-219 °C		VPR 235 +5/-0 °C
IR/Convection 220 +5/-0 °C		IR/Convection 235 +5/-0 °C

Reliability test program

Test item	Method	Description
SOLDERABILITY	MIL-STD-883D-2003	245°C , 5 SEC
HOLT	MIL-STD-883D-1005.7	1000 Hrs Bias @ 125 °C
PCT	JESD-22-B, A102	168 Hrs, 100 % RH , 121°C
TST	MIL-STD-883D-1011.9	-65°C ~ 150°C, 200 Cycles
ESD	MIL-STD-883D-3015.7	VHBM > 2KV, VMM > 200V
Latch-Up	JESD 78	10ms , I _{tr} > 100mA

Carrier Tape & Reel Dimension

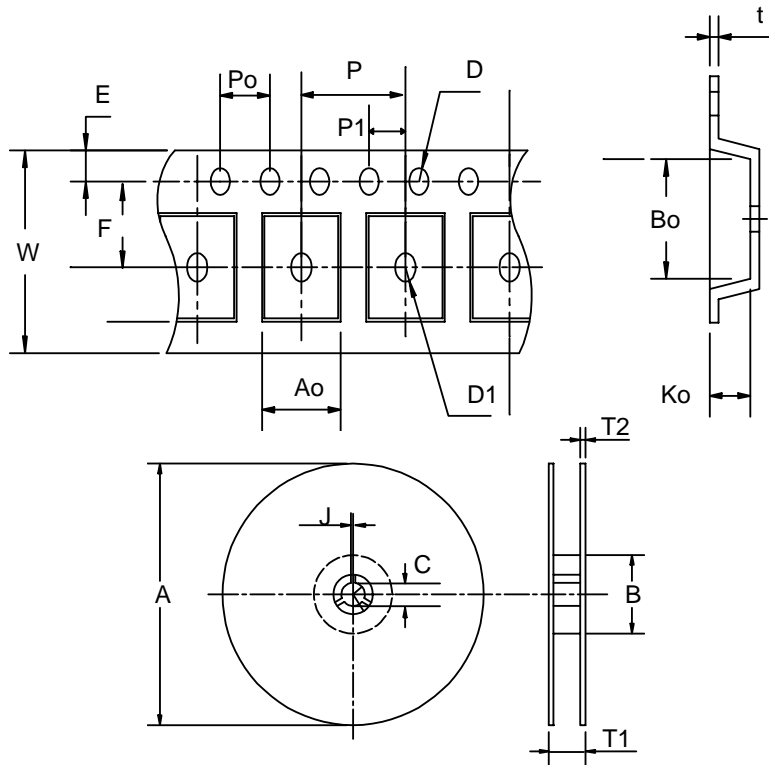

Application	A	B	C	J	T1	T2	W	P	E
TO-263	380±3	80±2	13±0.5	2±0.5	24±4	2±0.3	24 ^{+0.3} _{-0.1}	16±0.1	1.75±0.1
	F	D	D1	Po	P1	Ao	Bo	Ko	t
	11.5±0.1	1.5+0.1	1.5±0.25	4.0±0.1	2.0±0.1	10.8±0.1	16.1±0.1	5.2±0.1	0.35±0.013
Application	A	B	C	J	T1	T2	W	P	E
TO-252	330±3	100±2	13±0.5	2±0.5	16.4 ^{+0.3} _{-0.2}	2.5±0.5	16 ^{+0.3} _{-0.1}	8±0.1	1.75±0.1
	F	D	D1	Po	P1	Ao	Bo	Ko	t
	7.5±0.1	1.5+0.1	1.5±0.25	4.0±0.1	2.0±0.1	6.8±0.1	10.4±0.1	2.5±0.1	0.3±0.05

Cover Tape Dimensions

Application	Carrier Width	Cover Tape Width	Devices Per Reel
TO- 263	24	21.3	1000
TO- 252	16	13.3	2500

Customer Service

Anpec Electronics Corp.

Head Office :

5F, No. 2 Li-Hsin Road, SBIP,

Hsin-Chu, Taiwan, R.O.C.

Tel : 886-3-5642000

Fax : 886-3-5642050

Taipei Branch :

7F, No. 137, Lane 235, Pac Chiao Rd.,

Hsin Tien City, Taipei Hsien, Taiwan, R. O. C.

Tel : 886-2-89191368

Fax : 886-2-89191369