

## 450mA Low Dropout Linear Regulator of Adjustable and Fixed Voltages

### Features

- Low Dropout Voltage of 1.3V at 450mA
- Output Voltage Accuracy  $\pm 2.0\%$
- Line Regulation - 3mV (typ.)
- Load Regulation - 13mV (typ.)
- Input Voltage Range up to 9V
- Internal Current Limiting and Thermal Shutdown Protections
- Available Output Voltages -ADJ, 1.8V, 2.5V, 2.6V, 2.7V, 2.8V, 3.3V
- Various SOT-89 and TO-92 Packages Available

### Applications

- Voltage Regulator for CD-ROM Drivers
- Voltage Regulator for LAN Cards
- Wireless Communication Systems
- Portable Instrument
- Portable Consumer Equipment
- Low Voltage Systems

### General Description

The APL5835 is a 3-pin low dropout linear regulator with 2.0% accuracy of output voltage over line, load and temperature variations. Dropout voltage at 450mA output current is less than 1.3V. Both output current limiting and thermal shutdown are built in to provide maximal protection to the APL5835 against fault conditions. The over current and thermal shutdown circuits become active when the current exceed 450mA, or the junction temperature reach 150°C. Normal operation is recovered when junction temperature drops below 130°C.

### Pin Description

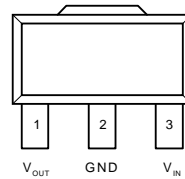

SOT-89 (Top View)

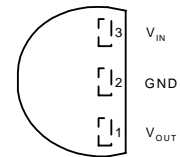

TO-92 (Top View)

## Ordering and Marking Information

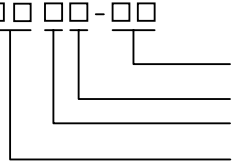
<p>APL5835 - □□□□-□□</p>  <p>Handling Code Temp. Range Package Code Voltage Code</p>	<p>Package Code D : SOT-89      E : TO-92 Temp. Range C : 0 to 70 °C Handling Code TU : Tube      TR : Tape &amp; Reel Voltage Code 18 : 1.8V      25 : 2.5V      26 : 2.6V      27 : 2.7V 33 : 2.8V      33 : 3.3V      Blank : Adjustable Version</p>
<p>APL5835 D : <span style="border: 1px solid black; padding: 2px;">APL5835 XXXXX</span>    XXXXX - Date Code</p>	<p>APL5835 E : <span style="border: 1px solid black; padding: 2px;">APL 5835 XXXXX</span>    XXXXX - Date Code</p>
<p>APL5835 -18 D : <span style="border: 1px solid black; padding: 2px;">APL5835 XXXXX18</span>    XXXXX - Date Code</p>	<p>APL5835 -18 E : <span style="border: 1px solid black; padding: 2px;">APL 5835 XXXXX18</span>    XXXXX - Date Code</p>
<p>APL5835 -25 D : <span style="border: 1px solid black; padding: 2px;">APL5835 XXXXX25</span>    XXXXX - Date Code</p>	<p>APL5835 -25 E : <span style="border: 1px solid black; padding: 2px;">APL 5835 XXXXX25</span>    XXXXX - Date Code</p>
<p>APL5835 -26 D : <span style="border: 1px solid black; padding: 2px;">APL5835 XXXXX26</span>    XXXXX - Date Code</p>	<p>APL5835 -26 E : <span style="border: 1px solid black; padding: 2px;">APL 5835 XXXXX26</span>    XXXXX - Date Code</p>
<p>APL5835 -27 D : <span style="border: 1px solid black; padding: 2px;">APL5835 XXXXX27</span>    XXXXX - Date Code</p>	<p>APL5835 -27 E : <span style="border: 1px solid black; padding: 2px;">APL 5835 XXXXX27</span>    XXXXX - Date Code</p>
<p>APL5835 -28 D : <span style="border: 1px solid black; padding: 2px;">APL5835 XXXXX28</span>    XXXXX - Date Code</p>	<p>APL5835 -28 E : <span style="border: 1px solid black; padding: 2px;">APL 5835 XXXXX28</span>    XXXXX - Date Code</p>
<p>APL5835 -33 D : <span style="border: 1px solid black; padding: 2px;">APL5835 XXXXX33</span>    XXXXX - Date Code</p>	<p>APL5835 -33 E : <span style="border: 1px solid black; padding: 2px;">APL 5835 XXXXX33</span>    XXXXX - Date Code</p>

## Block Diagram

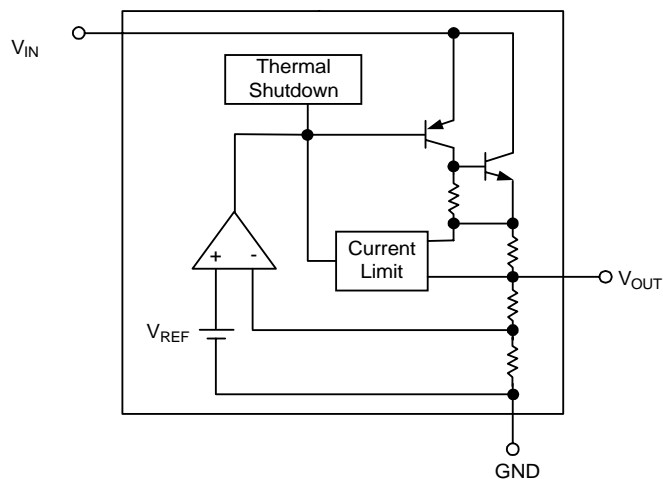

## Absolute Maximum Ratings

Symbol	Parameter	Rating	Unit
$V_{IN}$	Input Voltage	9	V
$I_{OUT}$	Output Current	450	mA
$T_A$	Operating Ambient Temperature Range	0 to 70	°C
$T_J$	Operating Ambient Temperature Range	-40 to +150	°C
$T_{STG}$	Storage Temperature Range	-65 to +150	°C
$P_D$	Power Dissipation Package	Interanl Limited	
$\theta_{JA}$	Thermal Resistance	SOT-89	180
		TO-92	180

## Electrical Characteristics cont. ( $T_A=25^\circ\text{C}$ , unless otherwise noted)

Symbol	Parameter	Test Condition	APL5835			Unit
			Min.	Typ.	Max.	
$V_N$	Input Voltage		$V_{OUT} + 1.45V$		8	V
$V_{OUT}$	Output Voltage	$I_{OUT}=10\text{mA}$	$0.9 V_{OUT}$		$1.02 V_{OUT}$	V
$I_{OUT}$	Output Current Capability	$\Delta V_{OUT}=2\%$	450			mA
$I_{SC}$	Short Circuit Current	$V_{OUT}<0.4V$		600		mA
$I_Q$	Quiescent Current	$V_N=5V$ , No Load		6	10	mA
REG <sub>LINE</sub>	Line Regulation APL5835 APL5835-18 APL5835-25 APL5835-26 APL5835-27 APL5835-28 APL5835-33	$T_J=0\sim 125^\circ\text{C}$ $I_{OUT}=10\text{mA}$ , $V_{OUT}+1.7V\leq V_{IN}\leq 8V$ $I_{OUT}=0\text{A}$ , $3.5V\leq V_{IN}\leq 8V$ $I_{OUT}=0\text{A}$ , $4.2V\leq V_{IN}\leq 8V$ $I_{OUT}=0\text{A}$ , $4.3V\leq V_{IN}\leq 8V$ $I_{OUT}=0\text{A}$ , $4.4V\leq V_{IN}\leq 8V$ $I_{OUT}=0\text{A}$ , $4.5V\leq V_{IN}\leq 8V$ $I_{OUT}=0\text{A}$ , $5V\leq V_{IN}\leq 8V$		3	6	mV
REG <sub>LOAD</sub>	Load Regulation APL5835 APL5835-18 APL5835-25 APL5835-26 APL5835-27 APL5835-28 APL5835-33	$T_J=0\sim 125^\circ\text{C}$ $(V_{IN}-V_{OUT})=1.7V$ , $0\leq I_{OUT}\leq 0.45\text{A}$ $V_{IN}=3.5V$ , $0\leq I_{OUT}\leq 0.45\text{A}$ $V_{IN}=4.2V$ , $0\leq I_{OUT}\leq 0.45\text{A}$ $V_{IN}=4.5V$ , $0\leq I_{OUT}\leq 0.45\text{A}$ $V_{IN}=4.4V$ , $0\leq I_{OUT}\leq 0.45\text{A}$ $V_{IN}=4.5V$ , $0\leq I_{OUT}\leq 0.45\text{A}$ $V_{IN}=5V$ , $0\leq I_{OUT}\leq 0.45\text{A}$		13	20	mV
$V_{DROPOUT}$	Dropout Voltage	$I_{OUT}=450\text{mA}$ , $\Delta V_{OUT}=1\%$		1300	1450	mV
PSRR	Power Supply Rejection Ratio	at 1kHz		55		dB
OTS	Over Temperature Shutdown			150		°C
$E_N$	Output Noise			100		$\mu\text{Vrms}$
TC	Output Voltage Temperature Coefficient			100		ppm/°C

## Application Schematic

1.25V to 7V Adjustable Regulator

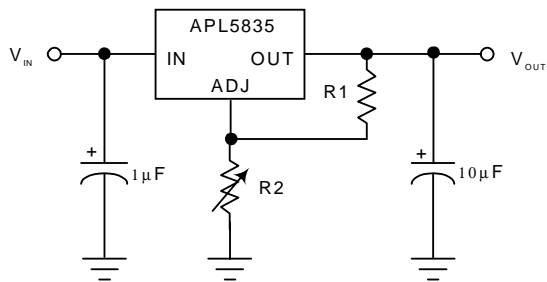

$$V_{OUT} = 1.250V \times \frac{R1 + R2}{R1}$$

Fixed 1.8V, 2.5V, 2.6V, 2.7V, 2.8V and 3.3V Regulator

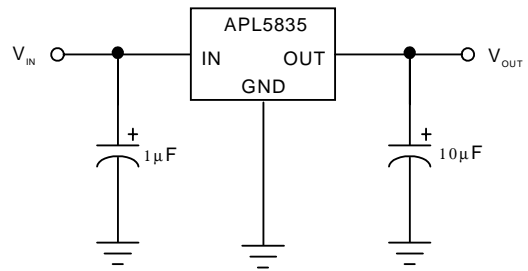

## Typical Characteristics

Output Voltage vs. Temperature

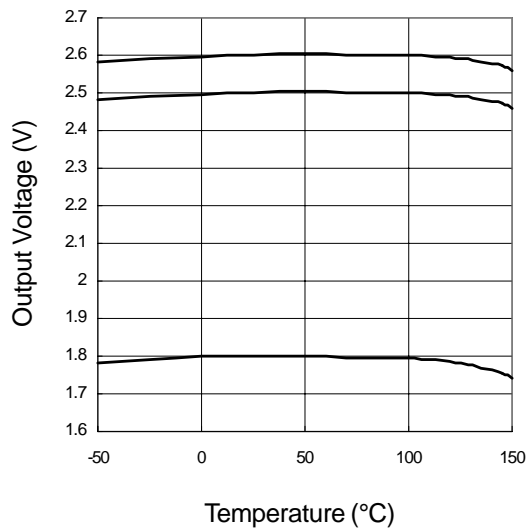

Output Voltage vs. Temperature

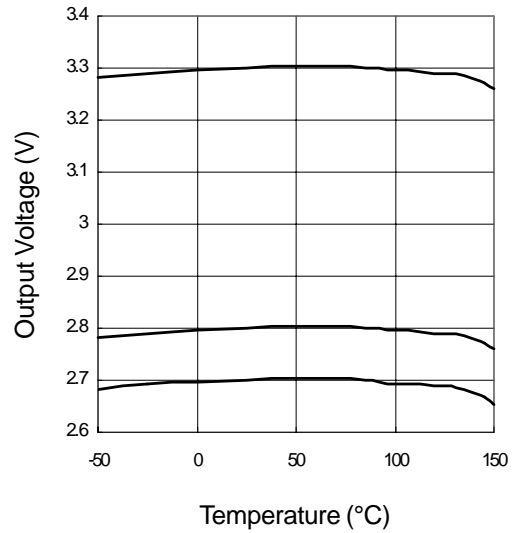

Line Transient Response

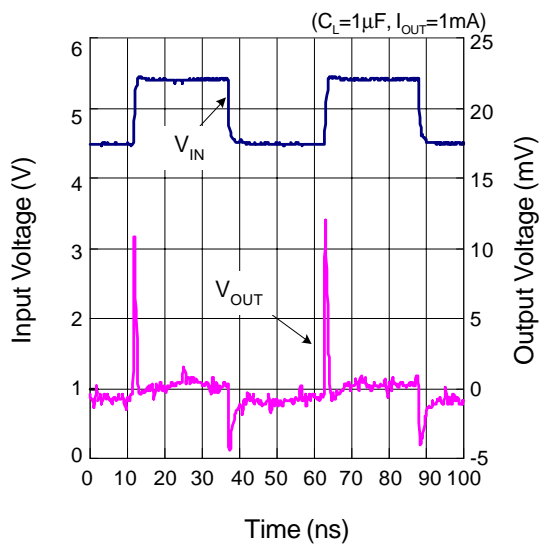

Line Transient Response

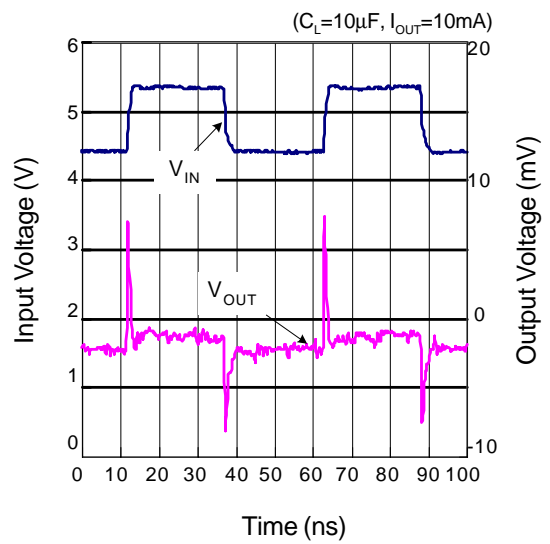

## Typical Characteristics

Load Transient Response

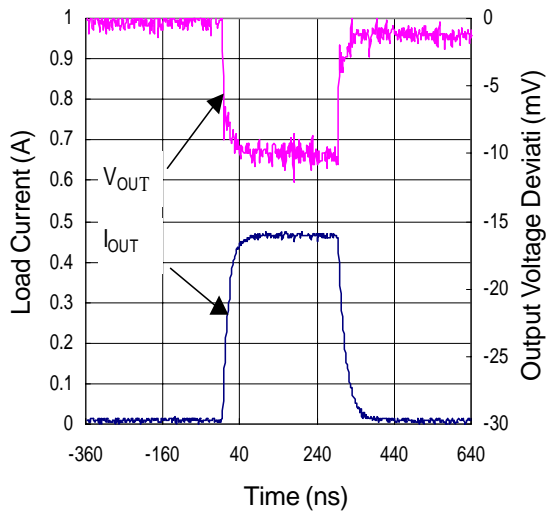

Output Voltage vs. Input Voltage

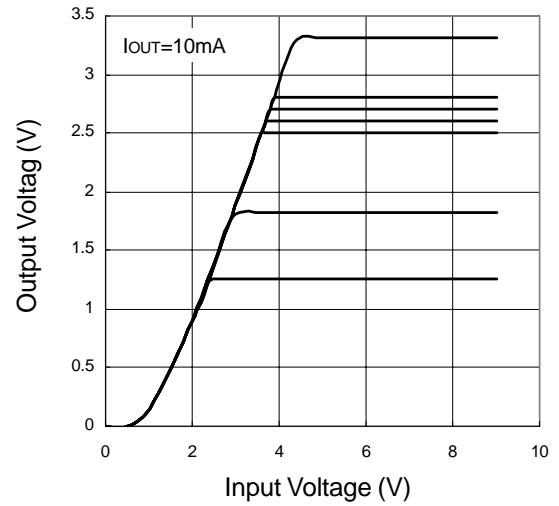

Short Current vs. Temperature

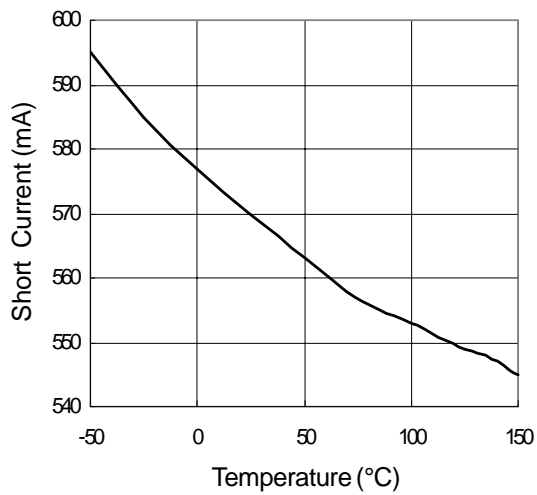

Output Current vs. Load Regulation

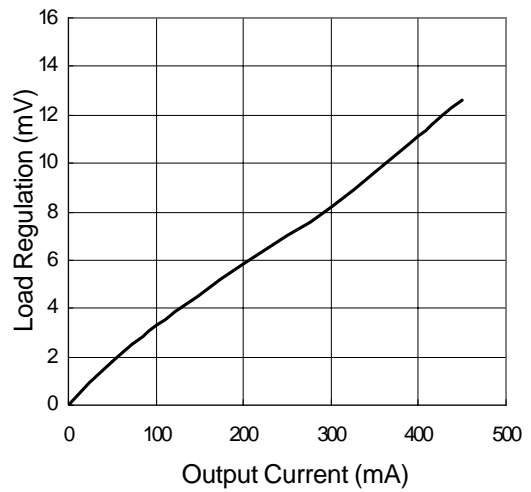

Typical Characteristics Cont.

Short Current vs. Input Voltage

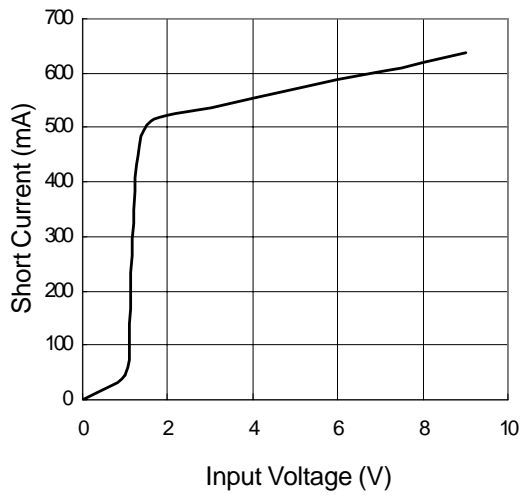

Output Current vs. Dropout Voltage

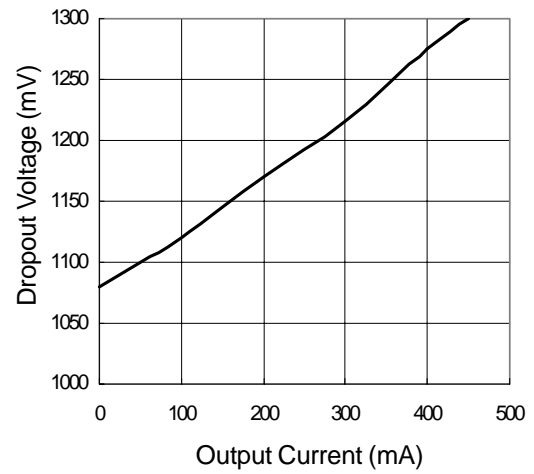

Input Current vs. Temperature

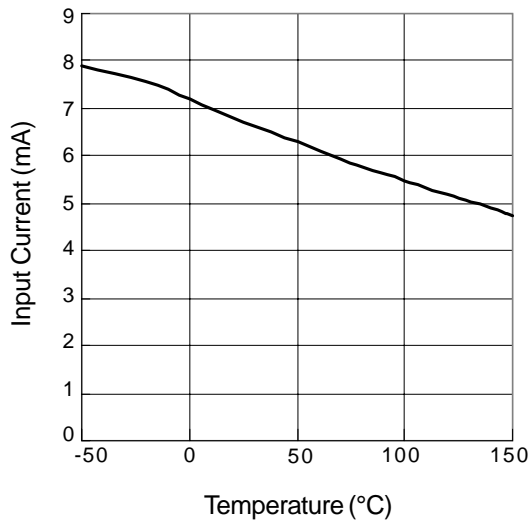

Input Current vs. Input Voltage

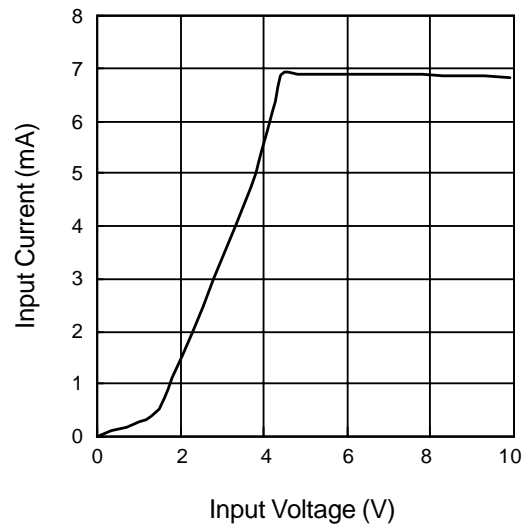

## Packaging Information

TO-92

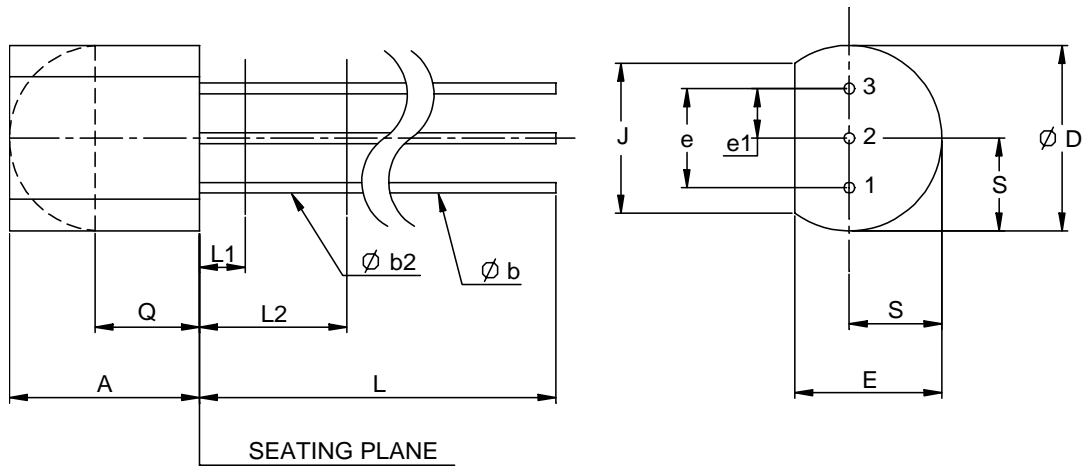

Dim	Millimeters		Inches	
	Min.	Max.	Min.	Max.
A	4.58	5.33	0.170	0.210
φ b	0.41	0.53	0.160	0.021
φ b2	0.41	0.48	0.160	0.019
φ D	4.96	5.20	0.175	0.205
E	3.94	4.19	0.125	0.165
e	2.42	2.66	0.095	0.105
e1	1.15	1.39	0.045	0.055
J	3.43		0.135	
L	12.70		0.500	
L1		1.27		0.050
L2	6.35		0.250	
Q	2.93		0.115	
S	2.42	2.66	0.080	0.105



## Packaging Information

SOT-89 (Reference EIAJ ED-7500A Registration SC-62)

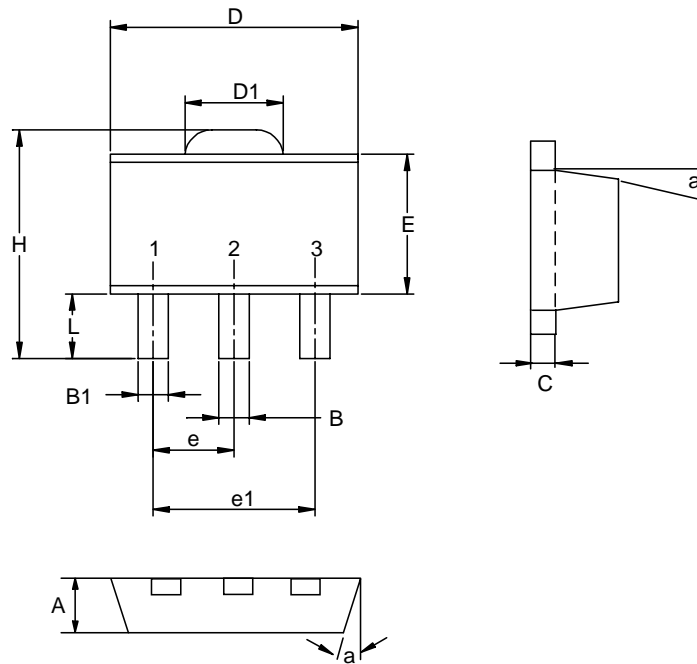

Dim	Millimeters		Inches	
	Min.	Max.	Min.	Max.
A	1.40	1.60	0.055	0.063
B	0.40	0.56	0.016	0.022
B1	0.35	0.48	0.014	0.019
C	0.35	0.44	0.014	0.017
D	4.40	4.60	0.173	0.181
D1	1.35	1.83	0.053	0.072
e	1.50 BSC		0.059 BSC	
e1	3.00 BSC		0.118 BSC	
E	2.29	2.60	0.090	0.102
H	3.75	4.25	0.148	0.167
L	0.80	1.20	0.031	0.047
α		10°		10°

## Physical Specifications

Terminal Material	Solder-Plated Copper (Solder Material : 90/10 or 63/37 SnPb)
Lead Solderability	Meets EIA Specification RSI86-91, ANSI/J-STD-002 Category 3.

### Reflow Condition (IR/Convection or VPR Reflow)

Reference JEDEC Standard J-STD-020A APRIL 1999

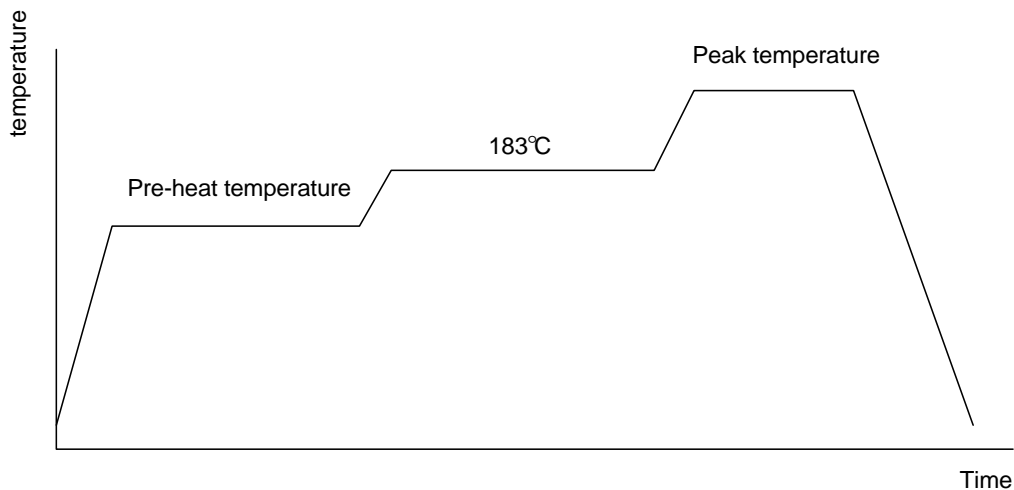

### Classification Reflow Profiles

	Convection or IR/ Convection	VPR
Average ramp-up rate(183°C to Peak)	3°C/second max.	10°C /second max.
Preheat temperature 125 ± 25°C)	120 seconds max.	
Temperature maintained above 183°C	60 ~ 150 seconds	
Time within 5°C of actual peak temperature	10 ~ 20 seconds	60 seconds
Peak temperature range	220 +5/-0°C or 235 +5/-0°C	215~ 219°C or 235 +5/-0°C
Ramp-down rate	6°C /second max.	10°C /second max.
Time 25°C to peak temperature	6 minutes max.	

pkg. thickness ≥ 2.5mm and all bags	pkg. thickness < 2.5mm and pkg. volume ≥ 350 mm	pkg. thickness < 2.5mm and pkg. volume <
Convection 220 +5/-0°C		Convection 235 +5/-0°C
VPR 215-219°C		VPR 235 +5/-0°C
IR/Convection 220 +5/-0°C		IR/Convection 235 +5/-0°C

## Reliability test Program

Test item	Method	Description
SOLDERABILITY	MIL-STD-883D-2003	245° C , 5 SEC
HOLT	MIL-STD-883D-1005.7	1000 Hrs Bias @ 125 °C
PCT	JESD-22-B, A102	168 Hrs, 100 % RH , 121 °C
TST	MIL-STD-883D-1011.9	-65° C ~ 150° C , 200 Cycles
ESD	MIL-STD-883D-3015.7	VHBM > 2KV, VMM > 200V
Latch-Up	JESD 78	10ms , I <sub>tr</sub> > 100mA

## Carrier Tape & Reel Dimensions

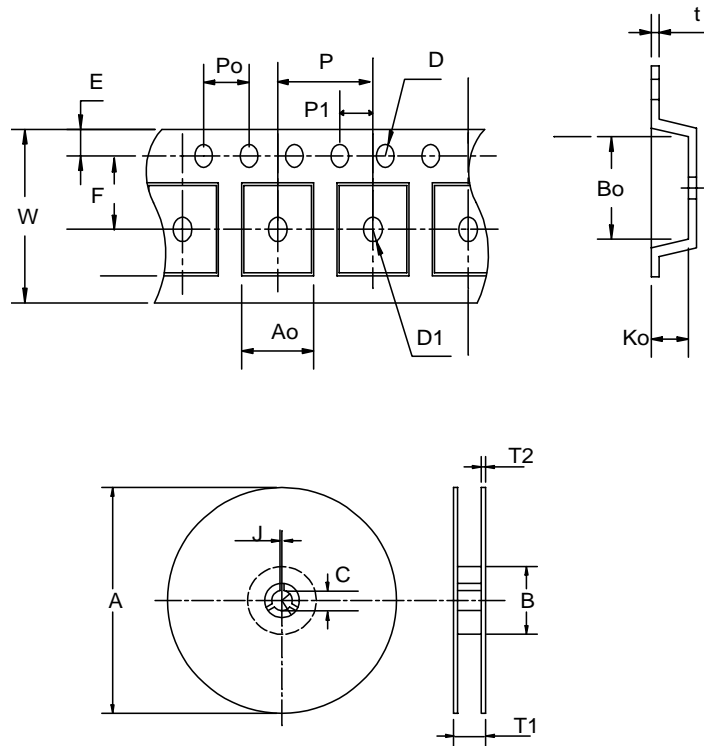

<b>Application</b>	A	B	C	J	T1	T2	W	P	E
<b>SOT-89</b>	178 ± 1	70 ± 2	13.5 ± 0.15	3 ± 0.15	14 ± 2	1.3 ± 0.3	12 + 0.3 12 - 0.1	8 ± 0.1	1.75 ± 0.1
<b>Application</b>	F	D	D1	Po	P1	Ao	Bo	Ko	t
<b>SOT-89</b>	5.5 ± 0.05	1.5 ± 0.1	1.5 ± 0.1	4.0 ± 0.1	2.0 ± 0.1	4.8 ± 0.1	4.5 ± 0.1	1.80 ± 0.1	0.3 ± 0.013

(mm)

## Cover Tape Dimensions

Application	Carrier Width	Cover Tape Width	Devices Per Reel
SOT- 89	12	9.3	1000

## Customer Service

### **Anpec Electronics Corp.**

Head Office :

5F, No. 2 Li-Hsin Road, SBIP,  
Hsin-Chu, Taiwan, R.O.C.  
Tel : 886-3-5642000  
Fax : 886-3-5642050

Taipei Branch :

7F, No. 137, Lane 235, Pac Chiao Rd.,  
Hsin Tien City, Taipei Hsien, Taiwan, R. O. C.  
Tel : 886-2-89191368  
Fax : 886-2-89191369