

MicroPower Microprocessor Reset Circuit

Features

- 1.2V to 5.5V Input Voltage Range
- Low Quiescent Current : less Than 1.5 μ A
- High accuracy detection threshold : \pm 1.5%
- Fixed trimmed reset thresholds for 1.5V, 1.75V, 2.32V, 2.63V, 2.93V, 3.08V, 3.9V, 4.38V.
- Reset Timeout Period 250ms
- Available output configurations
 - Open-drain output
 - CMOS active high output
 - CMOS active low output
- SOT-23 , SOT-23-5 and SOT-89 packages
- No external components

Applications

- Computers
- Cell Phones
- Portable Electronics
- μ P Power Supply Monitoring

General Description

The APR3021/2/3 are designed to monitor voltage supplies in μ P and digital systems. The quiescent current is extremely low, typically 1.5 μ A, making it ideal for portable battery operated equipment. The APR3021/2/3 operate by monitoring the system power supply voltage. When the input voltage drops below a fixed threshold, the device asserts a reset signal for a fixed time period after V_{cc} rises above the fixed threshold. The APR3021/2/3 series is available with three output stage versions : APR3021 push-pull active low output, APR3022 push-pull active high output and APR3023 open drain active low output. They are also designed to reject fast line transient glitches on V_{cc} . The APR3021/2/3 are come in a miniature SOT-23, SOT-23-5, SOT-89 packages.

Pin Configuration

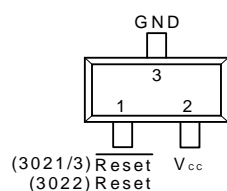

SOT-23 (Top View)

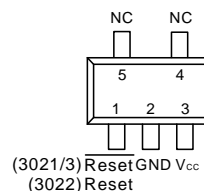

SOT-23-5 (Top View)

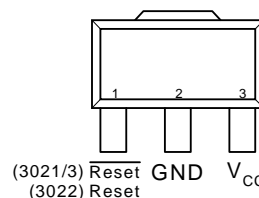

SOT-89 (Top View)

ANPEC reserves the right to make changes to improve reliability or manufacturability without notice, and advise customers to obtain the latest version of relevant information to verify before placing orders.

Ordering and Marking Information

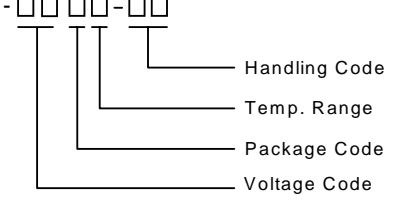
<p>APR3021/2/3 - □□□□ - □□</p>  <p>Handling Code Temp. Range Package Code Voltage Code</p>	<p>Package Code A : SOT-23 B : SOT-23-5 D : SOT-89 Temp. Range C : 0 to 70 °C I : -40 to 85 °C Handling Code TR : Tape & Reel Voltage Code : 15 : 1.5V ~ 43 : 4.38V</p>
<p>APR3021/2/3 A/B : 21/2/3 X X Date Code Voltage Code A:1.5V B:1.75V C:2.32V D:2.63V E:2.93V F:3.08V G:3.9V H:4.38V</p>	
<p>APR3021/2/3 -15 D : APR3021/2/3 XXXXX 15 XXXXX - Date Code ; 15 - 1.5V</p>	

Absolute Maximum Ratings

Symbol	Parameter	Value	Unit	
V _{CC}	V _{CC} to GND	-0.3 to 6	V	
V _{RESET}	RESET to GND (Push-Pull Output)	-0.3 to V _{CC} +0.3	V	
	RESET to GND (Open Drain Output)	-0.3 to 6		
I _{MAX}	Maximum Continuous Input Current	20	mA	
I _{RESET}	RESET/RESET Current	20	mA	
dV _{CC} /dt	Rate of Rise of V _{CC}	100	V/μs	
T _J	Junction Temperature Range	-40 to 150	°C	
T _L	Lead Temperature (Soldering, 10 second)	260	°C	
R _{TH,JA}	Thermal Resistance – Junction to Ambient	SOT-23	357	°C/W
		SOT-23-5	357	
		SOT-89	180	
P _D	Power Dissipation	Internally Limited	W	

Pin Description

PIN		Description
No.	Name	
1	RESET	RESET output remains low while V _{CC} is below the reset threshold and remains so for a fixed time period after V _{CC} raises above the reset threshold
	RESET	RESET output remains high while V _{CC} is below the reset threshold and remains so for a fixed time period after V _{CC} raises above the reset threshold.
2	V _{CC}	Supply Voltage (+1.2V to +6V)
3	GND	Ground connection

Note: The pin sequence here might not be correct for all different package types, and please refer pin configuration in page1 for correct pin assignment.

Block Diagram

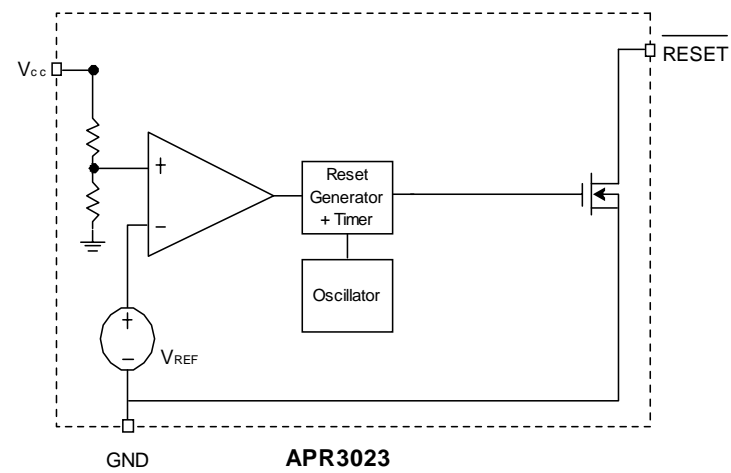
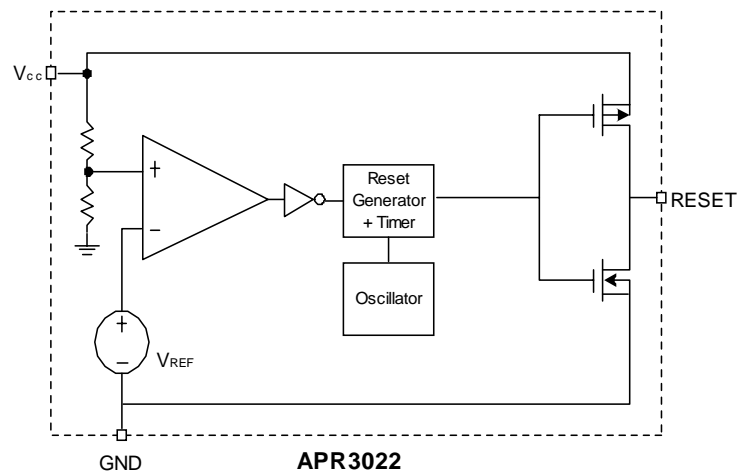
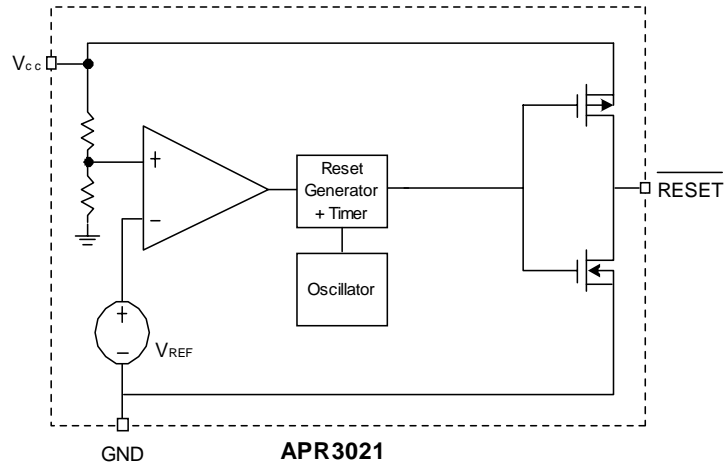

Part Number Description

Part Number	Part Description
APR3021	Reset Output Push Pull Active Low with Delay
APR3022	Reset Output Push Pull Active High with Delay
APR3023	Reset Output Open Drain Active Low with Delay

Electrical Characteristics

$V_{IN} = 5V$, $T_A = -40$ to $85^\circ C$ unless otherwise noted. Typical values are at $T_A=25^\circ C$, $V_{CC} = 5V$ for 4.38V versions, $V_{CC} = 3.3V$ for 3.08/2.93V versions, $V_{CC} = 3.0V$ for 2.63V. versions and $V_{CC} = 2.5V$ for 2.32V versions, $V_{CC} = 2.0V$ for 1.75V versions , $V_{CC} = 1.8V$ for 1.5V versions.

Symbol	Parameter	Test Conditions	APR3021/2/3			Unit
			Min.	Typ.	Max.	
V_{CC}	Supply Voltage		1.2		6	V
I_{CC}	Supply Current	$V_{CC}=1.5V\sim 6V$		1.5	4	μA
		$T_A=-40$ to $85^\circ C$		3	5	
V_{TH}	Reset Threshold	$T_A=25^\circ C$		$\pm 1.5\%$		
		$T_A=-40$ to $85^\circ C$		$\pm 2\%$		
V_{HYST}	Hysteresis Range			20		mV
T_{RTP}	Reset Timeout Period		150	250	350	ms
V_{OL}	Reset Output Low	$I_{SINK}=1.2mA$			0.5	V
V_{OH}	Reset Output High	$I_{SOURCE}=0.6mA$	$0.8*V_{CC}$			
T_D	V_{CC} to Reset Delay	$V_{CC}=V_{TH}$ to $(V_{TH}-100mV)$		25		μS
I_{LE}	Reset Output Leakage				0.5	μA

Application Circuit

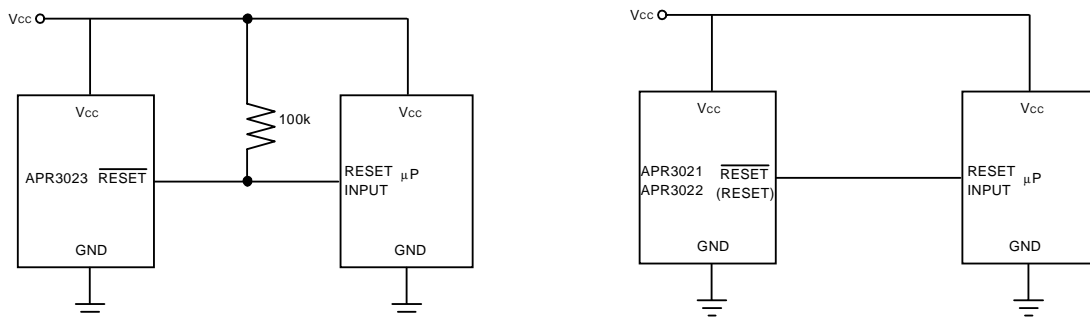

Timing Chart

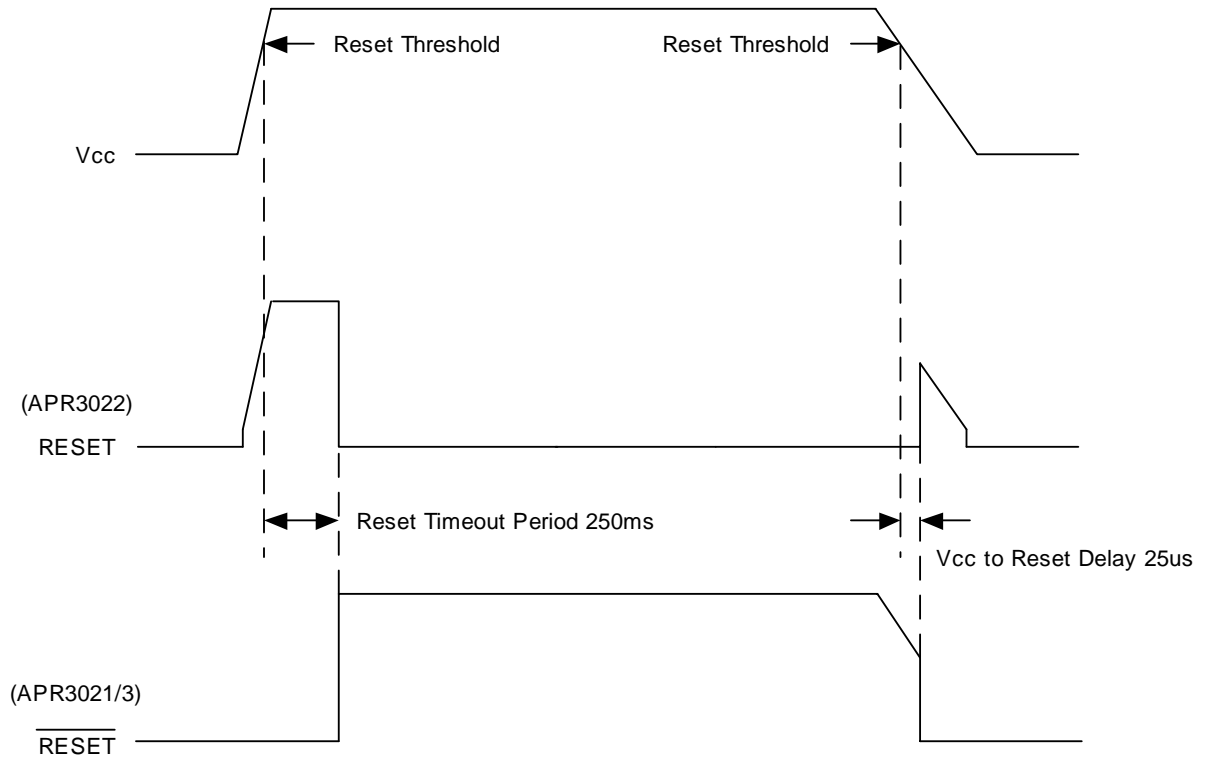

Typical Characteristics

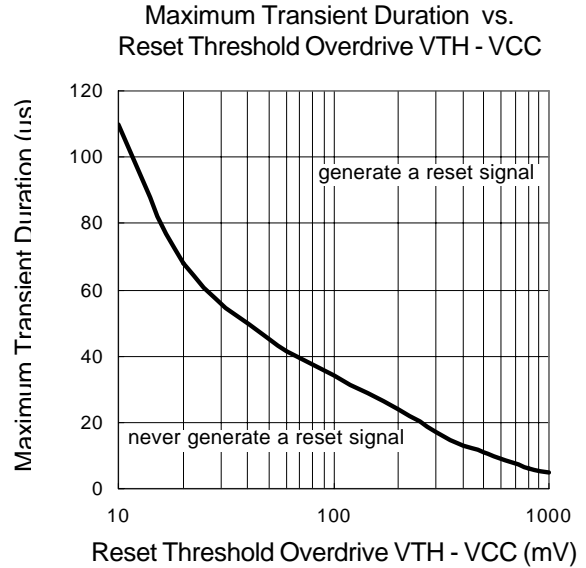
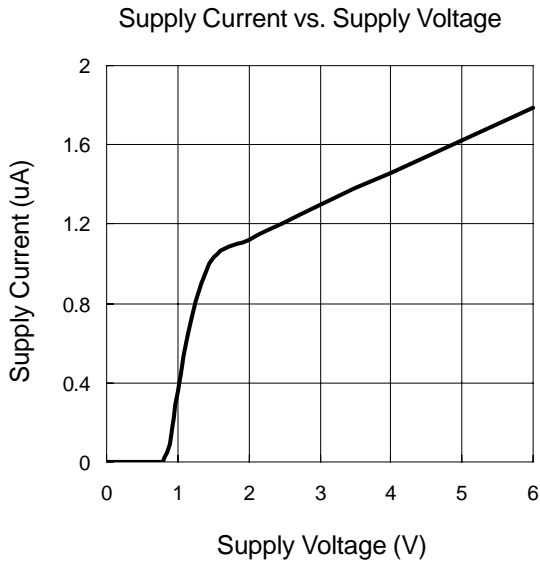

Output Source Current vs. Reset High Output Voltage

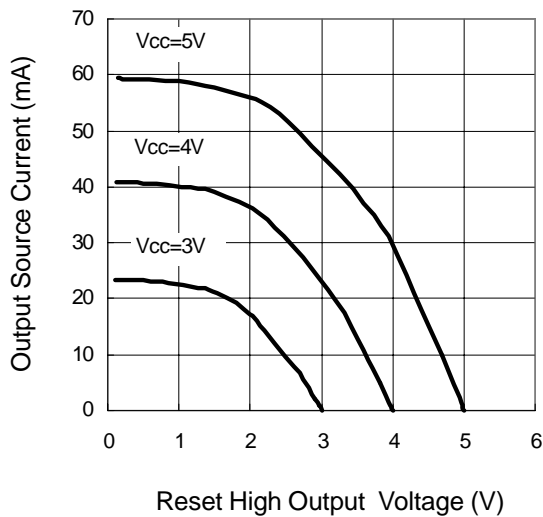

Output Sink Current vs. Reset Low Output Voltage

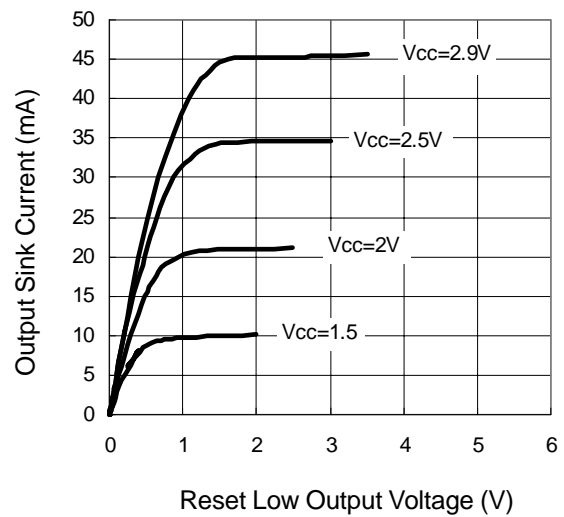

Typical Characteristics

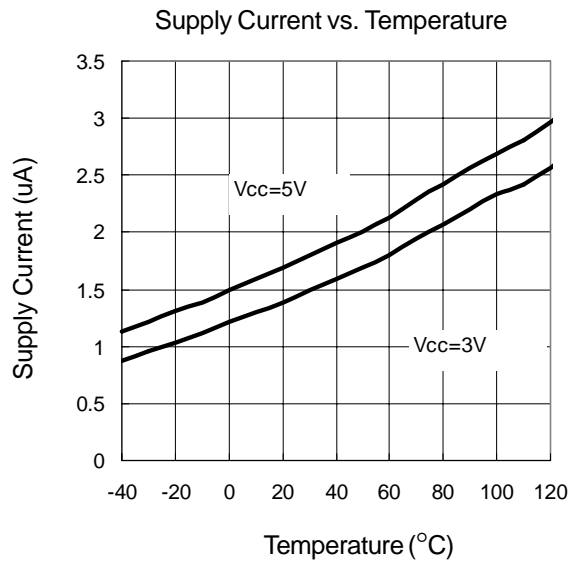
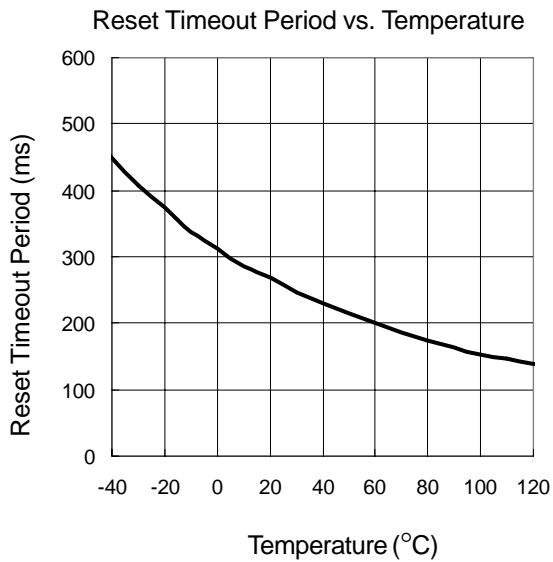
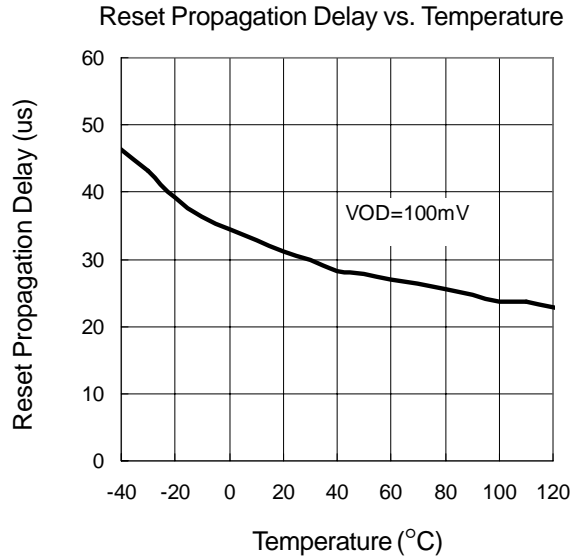
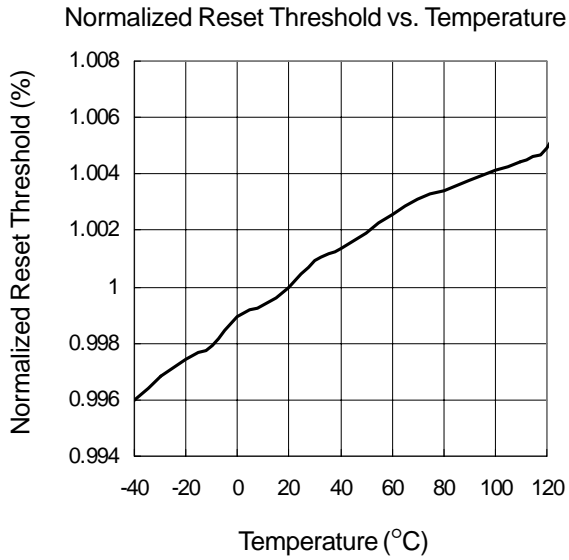

Typical Characteristics

Power Up

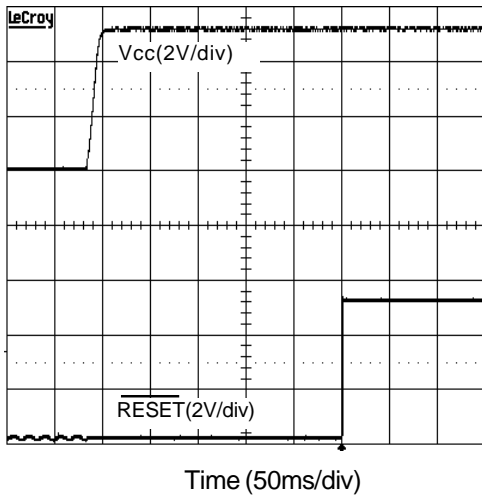

Power Down

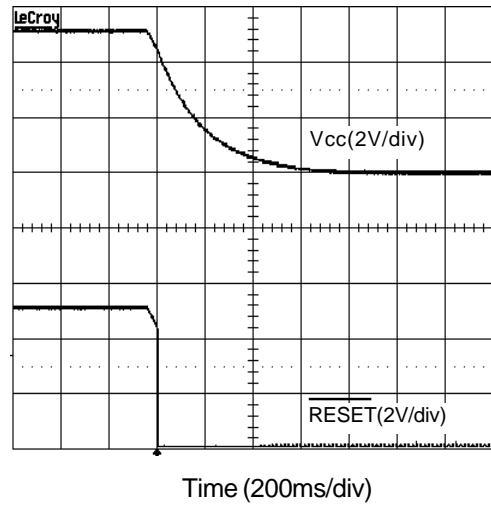

Vcc to RESET Delay

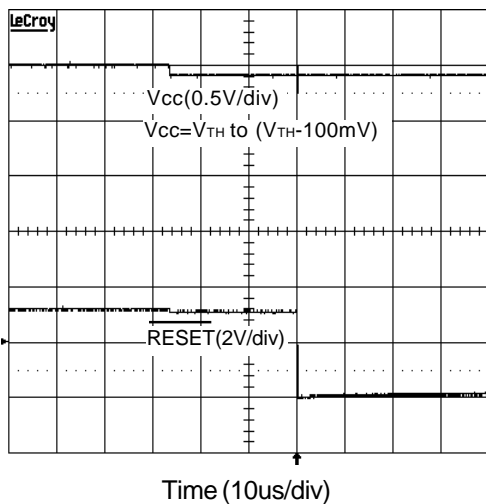

Application Information

V_{CC} Transient Rejection

The APR3021/2/3 have the function to reject the transient glitches from the power line. The Maximum Transient Duration vs. Reset Threshold Overdrive shows at Typical Characteristics. The transient voltage with the duration under the curve will not generate a reset signal, e.g. a transient of 100mV below the reset threshold voltage have the duration more than 35us, it will generate a reset signal. Connect a 0.1uF bypass capacitor to the V_{CC} pin can improve the transient immunity.

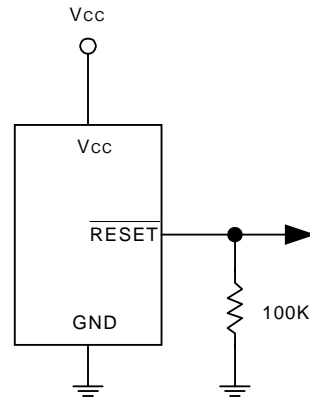

Figure 1. Ensuring RESET Valid to V_{CC} = 0 V

Reset Output

The APR3021/2/3 have 3 output stage versions: APR3001 is an active low push-pull output, when the V_{CC} drops below the reset threshold, the $\overline{\text{RESET}}$ output generates a low signal. APR3022 is an active high push-pull output, when the V_{CC} drops below the reset threshold, the RESET output generates a high signal (see Timing Chart). APR3023 is an active low open drain output, the RESET output must be connected a pull-up resistor to a supply voltage that is lower than 6V, it suits to use in multiple voltage systems (see Figure 2). The APR3021 RESET output is valid until the V_{CC}=1.2V, below 1.2V the IC is shutdown, and the output becomes a floating state. If it is a trouble, a resistor should be connected from reset output to ground to keep the reset output low (see Figure 1). For The APR3022, a pull-up resistor to V_{CC} is required to keep the valid reset output for V_{CC} below 1.2V.

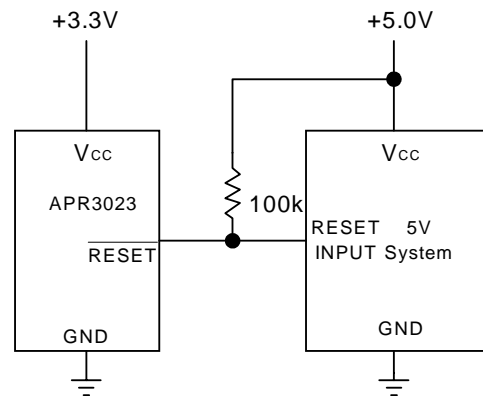
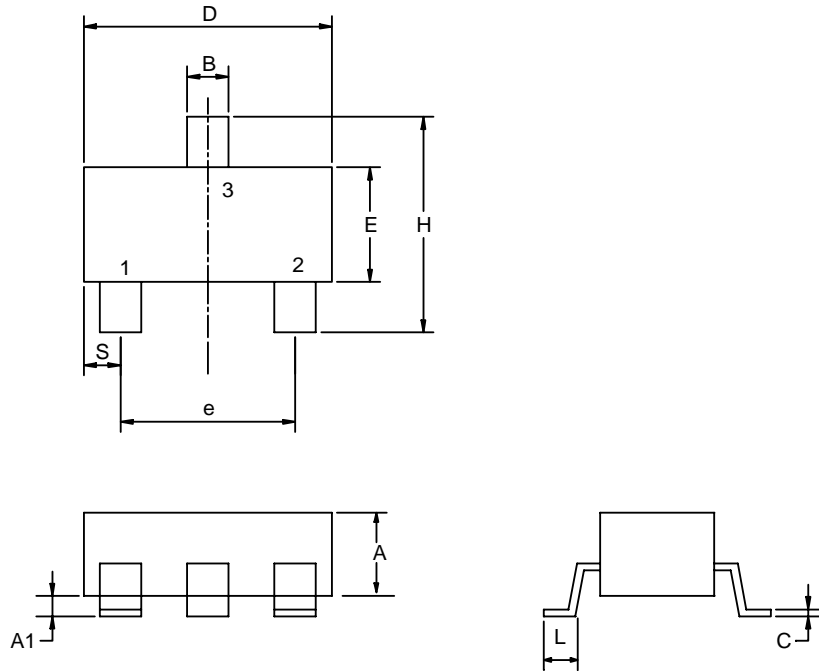

Figure 2. APR3023 Open Drain Output with Multiple Supplies

Packaging Information

SOT-23



Dim	Millimeters		Inches	
	Min.	Max.	Min.	Max.
A	1.00	1.30	0.039	0.051
A1	0.00	0.10	0.000	0.004
B	0.35	0.51	0.014	0.020
C	0.10	0.25	0.004	0.010
D	2.70	3.10	0.106	0.122
E	1.40	1.80	0.055	0.071
e	1.90 BSC		0.075 BSC	
H	2.40	3.00	0.094	0.118
L	0.37		0.0015	

Packaging Information

SOT-23-5

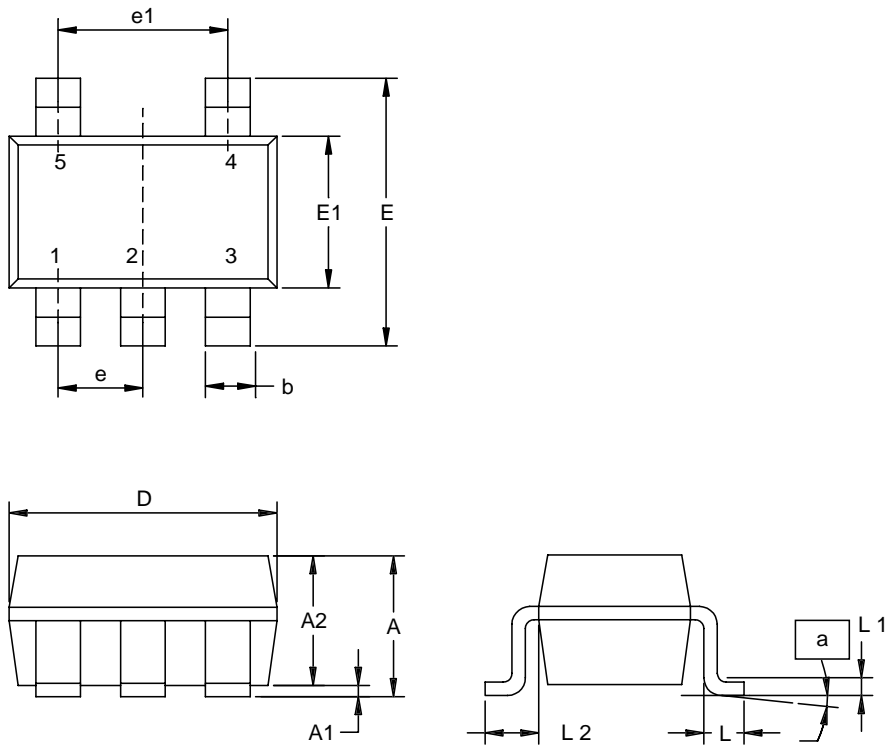

Dim	Millimeters		Inches	
	Min.	Max.	Min.	Max.
A	0.95	1.45	0.037	0.057
A1	0.05	0.15	0.002	0.006
A2	0.90	1.30	0.035	0.051
D	2.8	3.00	0.110	0.118
E	2.6	3.00	0.102	0.118
E1	1.5	1.70	0.059	0.067
L	0.35	0.55	0.014	0.022
L1	0.20 BSC		0.008 BSC	
L2	0.5	0.7	0.020	0.028
N	5		5	
α	0°	10°	0°	10°

Packaging Information

SOT-89 (Reference EIAJ ED-7500A Registration SC-62)

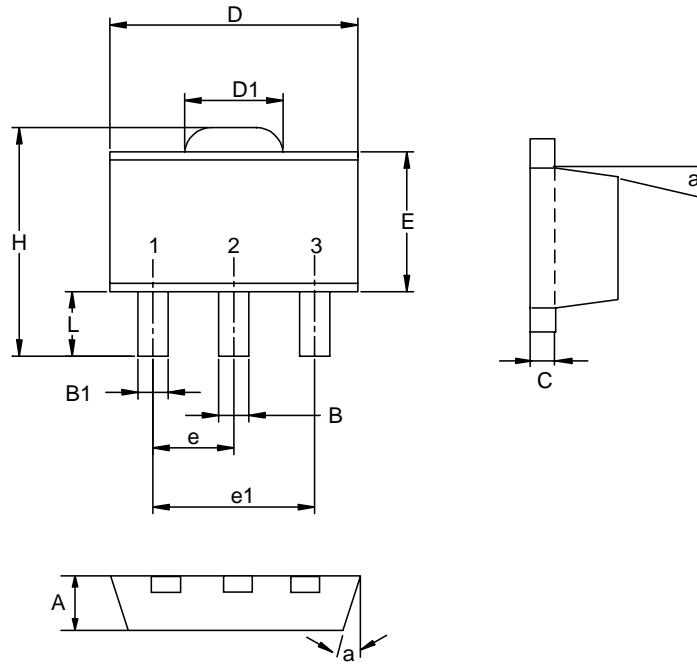

Dim	Millimeters		Inches	
	Min.	Max.	Min.	Max.
A	1.40	1.60	0.055	0.063
B	0.40	0.56	0.016	0.022
B1	0.35	0.48	0.014	0.019
C	0.35	0.44	0.014	0.017
D	4.40	4.60	0.173	0.181
D1	1.35	1.83	0.053	0.072
e	1.50 BSC		0.059 BSC	
e1	3.00 BSC		0.118 BSC	
E	2.29	2.60	0.090	0.102
H	3.75	4.25	0.148	0.167
L	0.80	1.20	0.031	0.047
α		10°		10°

Physical Specifications

Terminal Material	Solder-Plated Copper (Solder Material : 90/10 or 63/37 SnPb)
Lead Solderability	Meets EIA Specification RSI86-91, ANSI/J-STD-002 Category 3.

Reflow Condition (IR/Convection or VPR Reflow)

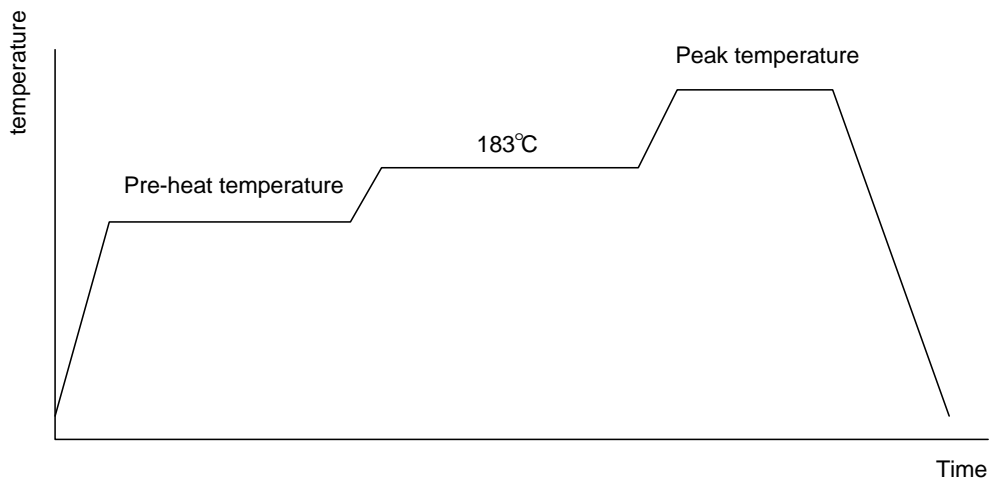

Classification Reflow Profiles

	Convection or IR/ Convection	VPR
Average ramp-up rate(183°C to Peak)	3°C/second max.	10 °C /second max.
Preheat temperature 125 ± 25°C)	120 seconds max	
Temperature maintained above 183°C	60 – 150 seconds	
Time within 5°C of actual peak temperature	10 –20 seconds	60 seconds
Peak temperature range	220 +5/-0°C or 235 +5/-0°C	215-219°C or 235 +5/-0°C
Ramp-down rate	6 °C /second max.	10 °C /second max.
Time 25°C to peak temperature	6 minutes max.	

Package Reflow Conditions

pkg. thickness ≥ 2.5mm and all bgas	pkg. thickness < 2.5mm and pkg. volume ≥ 350 mm ³	pkg. thickness < 2.5mm and pkg. volume < 350mm ³
Convection 220 +5/-0 °C		Convection 235 +5/-0 °C
VPR 215-219 °C		VPR 235 +5/-0 °C
IR/Convection 220 +5/-0 °C		IR/Convection 235 +5/-0 °C

Reliability test program

Test item	Method	Description
SOLDERABILITY	MIL-STD-883D-2003	245°C, 5 SEC
HOLT	MIL-STD 883D-1005.7	1000 Hrs Bias @ 125°C
PCT	JESD-22-B, A102	168 Hrs, 100% RH, 121°C
TST	MIL-STD 883D-1011.9	-65°C ~ 150°C, 200 Cycles

Carrier Tape & Reel Dimensions

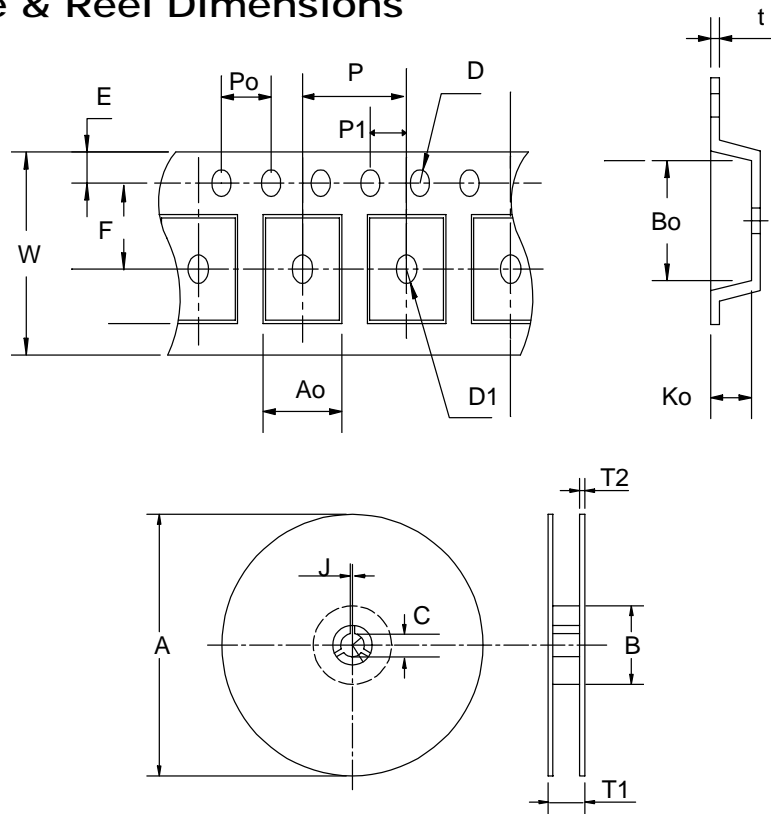

Application	A	B	C	J	T1	T2	W	P	E
SOT-23	178±1	60 ± 1.0	12.0	2.5 ± 0.15	9.0 ± 0.5	1.4	8.0+ 0.3 - 0.3	4.0	1.75
	3.5 ± 0.05	1.5 +0.1	φ 0.1MIN	4.0	2.0 ± 0.05	3.1	3.0	1.3	0.2±0.03
SOT-23-5	178 ± 1	72 ± 1.0	13.0 + 0.2	2.5 ± 0.15	8.4 ± 2	1.5 ± 0.3	8.0 ± 0.3	4 ± 0.1	1.75± 0.1
	3.5 ± 0.05	1.5± 0.1	1.5 ± 0.1	4.0 ± 0.1	2.0 ± 0.1	3.15 ± 0.1	3.2± 0.1	1.4± 0.1	0.2±0.033
SOT-89	178 ± 1	70 ± 2	13.5 ± 0.15	3 ± 0.15	14 ± 2	1.3 ± 0.3	12 + 0.3 12 - 0.1	8 ± 0.1	1.75± 0.1
	5.5 ± 0.05	1.5± 0.1	1.5 ± 0.1	4.0 ± 0.1	2.0 ± 0.1	4.8 ± 0.1	4.5± 0.1	1.80± 0.1	0.3±0.013

Cover Tape Dimensions

Application	Carrier Width	Cover Tape Width	Devices Per Reel
SOT- 23	8	5.3	3000
SOT- 23-5	8	5.3	3000
SOT- 89	12	9.3	1000

Customer Service

Anpec Electronics Corp.

Head Office :

5F, No. 2 Li-Hsin Road, SBIP,
Hsin-Chu, Taiwan, R.O.C.
Tel : 886-3-5642000
Fax : 886-3-5642050

Taipei Branch :

7F, No. 137, Lane 235, Pac Chiao Rd.,
Hsin Tien City, Taipei Hsien, Taiwan, R. O. C.
Tel : 886-2-89191368
Fax : 886-2-89191369