

# APExx08 Series

## DATA SHEET

### APLUS INTEGRATED CIRCUITS INC.

**Address:**

3 F-10, No. 32, Sec. 1, Chenggung Rd., Taipei,  
Taiwan 115, R.O.C.  
(115)台北市南港區成功路一段 32 號 3 樓之 10.

**TEL:** 886-2-2782-9266

**FAX:** 886-2-2782-9255

**WEBSITE :** <http://www.aplusinc.com.tw>

**Sales E-mail:**

[sales@plusinc.com.tw](mailto:sales@plusinc.com.tw)

**Technology E-mail:**

[service@plusinc.com.tw](mailto:service@plusinc.com.tw)

---

## 1.0 General Description

The **APExx08** series are very low cost voice and melody synthesizer with 4-bits CPU. They have various features including 4-bits ALU, ROM, RAM, I/O ports, timers, clock generator, voice and melody synthesizer, and PWM (Direct drive) or D/A current outputs, etc. The audio synthesizer contains one voice-channel and two melody-channels. Furthermore, they consist of 27 instructions in these devices. With CMOS technology and halt function can minimize power dissipation. Their architectures are similar to RISC, with two stages of instruction pipeline. They allow all instructions to be executed in a single cycle, except for program branches and data table read instructions (which need two instruction cycles).

## 2.0 Features

- (1) Single power supply can operate from 2.4V to 5.5V at 4MHz or 8MHz.
- (2) Program ROM: 16k x 10 bits
- (3) 1 set of 16-bits DPR can access up to 64k x 10 bits melody data memory space, and 1 set of 18-bits VPR can access up to 256k x 10 bits voice data memory space.

Product	Voice Duration (sec)	Voice Pointer (VPR)	ROM Size (10-bit)
APE0508	5	14-bits	16k
APE1008	10	15-bits	32k
APE1508	15	16-bits	48k
APE2008	20	16-bits	64k
APE3108	31	17-bits	96k
APE4108	41	17-bits	128k
APE5208	52	18-bits	160k
APE6308	63	18-bits	192k

- (4) Data Registers:
  - a). 128 x 4-bits data RAM (00-7Fh)  
(APE0508 /1008 is 96 x 4-bits data RAM 00-5Fh)
  - b). Unbanked special function registers (SFR) range: 00h-2Fh
- (5) I/O Ports:
  - a). PRA: 4-bits I/O Port A (10h) can be programmed to input/output individually. (Register control)
  - b). PRB: 4-bits I/O Port B (13h) can be configured to input/output individually. (Mask option)
- (6) On-chip clock generator: Resistive Clock Drive (**RM**)
- (7) Timer: 1-set Voice Interrupt (Timer0: a 9-bits auto-reload timer/counter).
- (8) Stack: 2-level subroutine nesting.
- (9) Built-in 4 Level Volume Control can be programmed.
- (10) Built-in 8 Level DAC current output can be configured. (Mask option)
- (11) Built-in IR Carry Output: Port B[1] can be configured as IR pin by 38k / 56kHz. (Mask option)

- (12) External Reset: Port B[3] can be configured as reset pin. (Mask option)
- (13) HALT and Release from HALT function to reduce power consumption
- (14) Watch Dog Timer (**WDT**)
- (15) Instruction: 1-cycle instruction except for table read and program branches which are 2-cycles
- (16) Number of instruction: 27
- (17) DAC: 1 channel voice and dual tone melody synthesizer (One 9-bits Cout or 8-bits PWM output).

**FIGURE 1 : ROM Map of APExx08 Series**

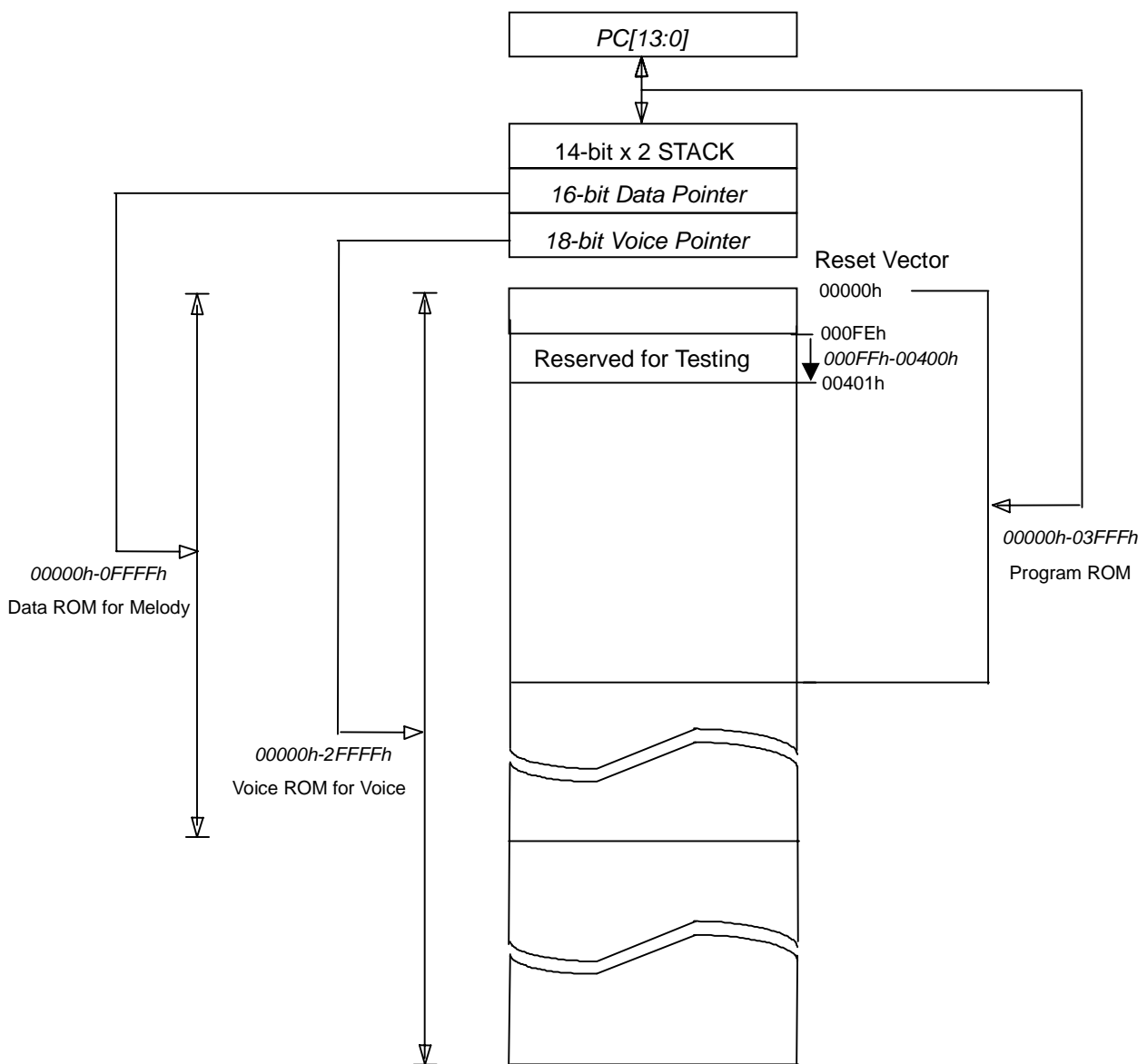

**3.0 Pin Description**

Pad Name	Pin Attr.	Description
PWM2/Cout	O	PWM2 output, or Current Output of Audio.
PWM1	O	PWM1 output.
Vdd1~2	Power	Power supply during operation.
PRA0~3	I/O	I/O port can be programmed to input/output individually. Input type with weak pull-low or fix-input-floating capability. Buffer Output type.
PRB0, PRB2	I/O	I/O port can be configured to input/output individually. Input type with weak pull-low or fix-input-floating capability. Buffer Output type.
PRB1 / IR	I/O	I/O port can be configured to input/output individually. Input type with weak pull-low or fix-input-floating capability. Buffer Output type. <i>Mask option selected as an IR Carrier Output with 38k / 56kHz</i>
PRB3 / Reset	I/O	I/O port can be configured to input/output individually. Input type with weak pull-low or fix-input-floating capability. Buffer Output type. <i>Mask option selected as an external RESET pin with weak pull-low capability.</i>
OSC	I	RM mode Oscillator input
GND1~2	Power	Ground Potential

**4.0 DC Characteristics**

Symbol	Parameter		Vdd	Min.	Typ.	Max.	Unit	Condition
Vdd	Operating voltage			2.4	3	5.5	V	depending on Freq.
Isb	Supply current	Standby	3			1	uA	4MHz, RM, in HALT Mode
			4.5			1		
Iop		Operating	3		2		mA	4MHz, RM, IO Floating
			4.5		7			
lih	Input current (Internal pull low)		3		4		uA	Input ports with weak pull-low
			4.5		10			
loh	Output-high current		3		-4		mA	4MHz, RM (IO ports)
			4.5		-10			
Iol	Output-low current		3		8.5		mA	4MHz, RM (IO ports)
			4.5		17.5			
Cout	DAC output current (8-level option)		3		0.8 ~ 4.8		mA	4MHz, RM (Full scale)
			4.5		0.9 ~ 6.5			
dF/F	Frequency stability			-5		5	%	$\frac{F_{osc}(3v-2.4v)}{F_{osc}(3v)}$
dF/F	Fosc lot variation			-10		10	%	Vdd=3V, Rosc=430k, 4MHz

FIGURE 2 : Frequency vs. Rosc (at 3V)

Resistor (Rosc ohms)	110k	200k	300k	430k
Frequency (MHz)	14.84	8.25	5.54	3.92

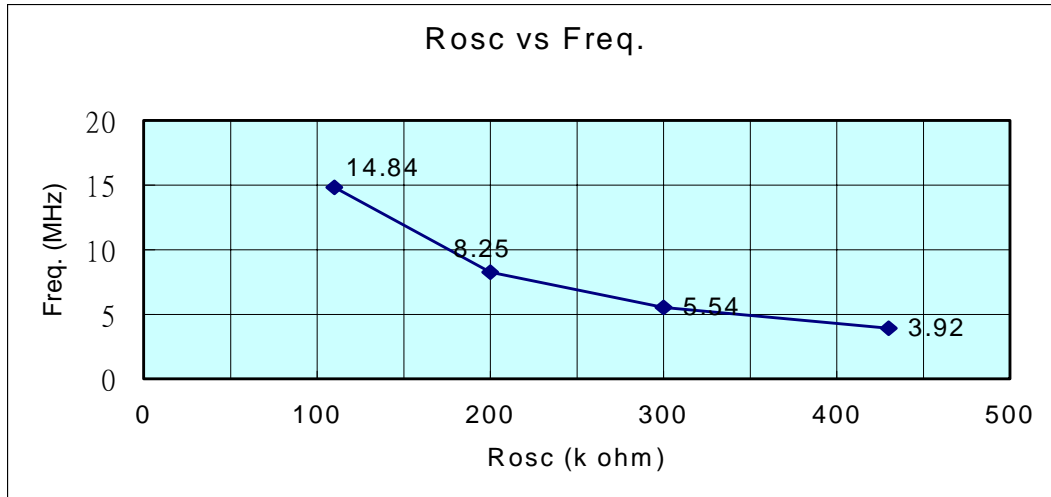

### 5.0 Application Circuit

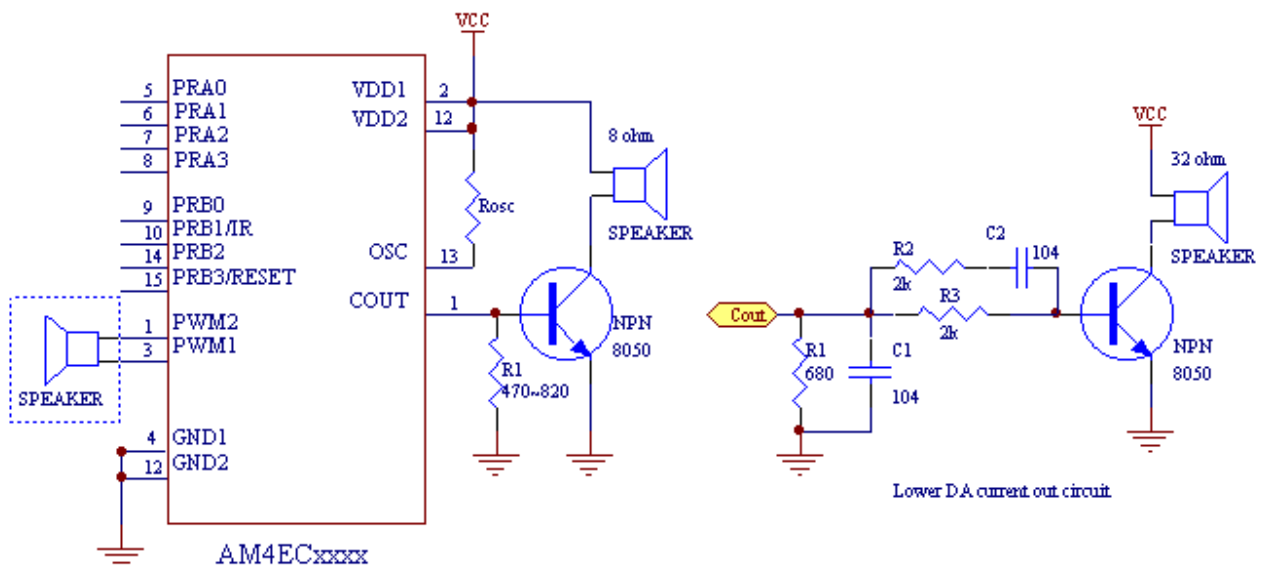

### 6.0 Bonding Diagram of APE0508 / APE1008

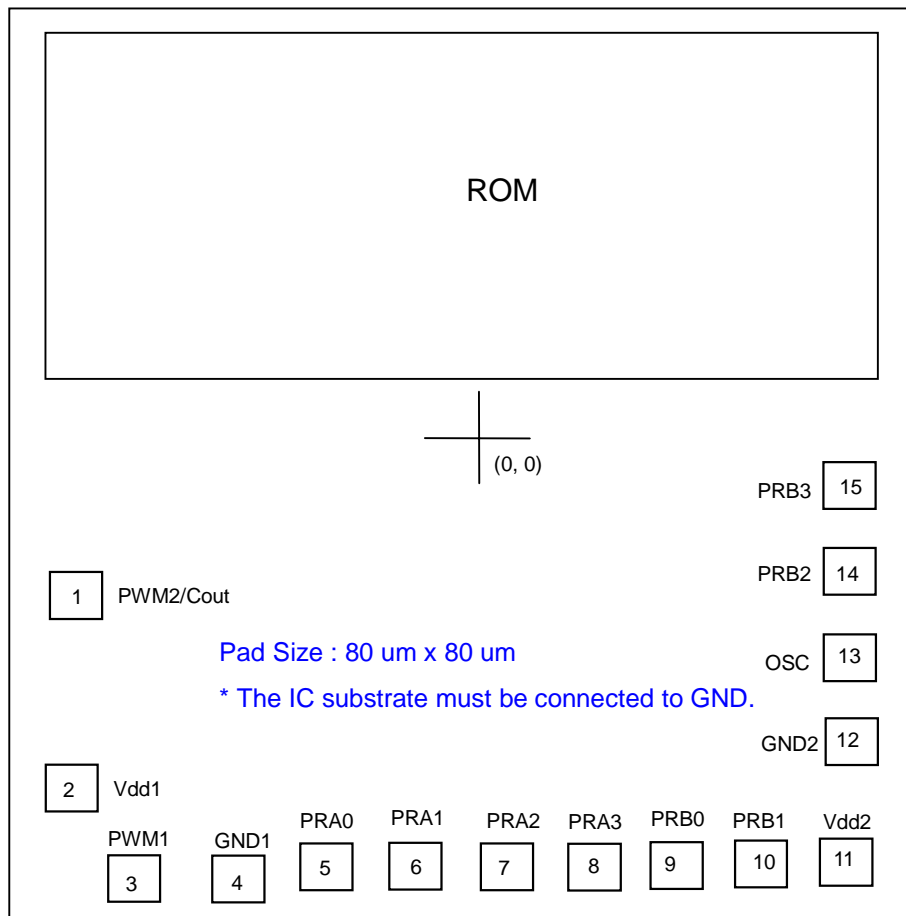

Pad #	Pad Name	X	Y	Pad #	Pad Name	X	Y
1	PWM2/Cout	-518	-195	9	PRB0	267	-574
2	Vdd1	-518	-479	10	PRB1	377	-574
3	PWM1	-431	-603	11	Vdd2	487	-574
4	GND1	-283	-603	12	GND2	489	-414
5	PRA0	-173	-574	13	OSC	489	-304
6	PRA1	-63	-574	14	PRB2	489	-194
7	PRA2	47	-574	15	PRB3	489	-84
8	PRA3	157	-574				

#### Chip Size :

APE0508 : 1234 um x 1404 um

APE1008 : 1234 um x 1404 um

### 6.1 Bonding Diagram of other APExx08 series

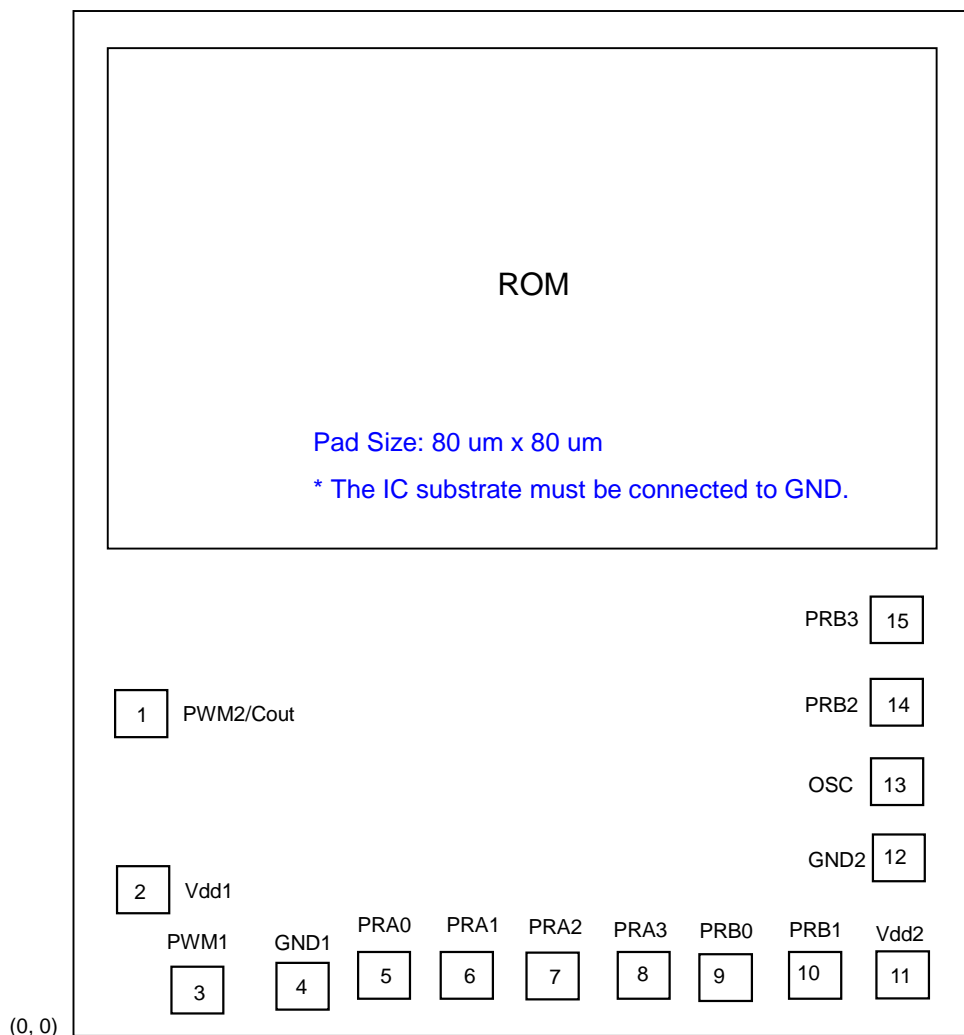

Pad #	Pad Name	X	Y	Pad #	Pad Name	X	Y
1	PWM2/Cout	58	466	9	PRB0	843	87
2	Vdd1	58	182	10	PRB1	953	87
3	PWM1	145	58	11	Vdd2	1063	87
4	GND1	293	58	12	GND2	1059	247
5	PRA0	403	87	13	OSC	1059	357
6	PRA1	513	87	14	PRB2	1059	467
7	PRA2	623	87	15	PRB3	1059	577
8	PRA3	733	87				

#### Chip Size :

APE1508 : 1230 um x 1848 um,      APE2008 : 1230 um x 1848 um  
 APE3108 : 1230 um x 1848 um,      APE4108 : 1230 um x 2528 um  
 APE5208 : 1230 um x 2528 um,      APE6308 : 1230 um x 2528 um