

AM93LC66

4096-bits Serial Electrically Erasable PROM

■ Features

- State-of-the-art architecture
 - Non-volatile data storage
 - Standard voltage and low voltage operation
Vcc: 2.7V ~ 5.5V
 - Full TTL compatible inputs and outputs
 - Auto increment read for efficient data dump
- Hardware and software write protection
 - Defaults to write-disabled state at power up
 - Software instructions for write-enable/disable
 - VCC level verification before self-timed programming cycle
- Advanced low voltage CMOS EEPROM technology
- Versatile, easy-to-use interface
 - Self-timed programming cycle
 - Automatic erase-before-write
 - Programming status indicator
 - Word and chip erasable
 - Stop SK anytime for power savings
- Durability and reliability
 - 40 years data retention
 - Minimum of 1M write cycles per word
 - Unlimited read cycles
 - ESD protection

■ General Description

The AM93LC66 is the 4096-bit non-volatile serial EEPROM. It is manufactured by using ATC's advanced CMOS EEPROM technology. The AM93LC66 provides efficient non-volatile read/write memory arranged as 256 words of 16 bits each when the ORG Pin is connected to VCC and 512 words of 8 bits each when it is tied to ground. The instruction set includes read, write, and write enable/disable functions. The data out pin (DO) indicates the status of the device during the self-timed non-volatile programming cycle.

The self-timed write cycle includes an automatic erase-before-write capability. Only when the chip is in the WRITE ENABLE state and proper VCC operation range is the WRITE instruction accepted and thus to protect against inadvertent writes. Data is written in 16 bits per write instruction into the selected register. If Chip Select (CS) is brought HIGH after initiation of the write cycle, the Data Output (DO) pin will indicate the READY/BUSY status of the chip.

The AM93LC66 is available in space-saving 8-lead PDIP, 8-lead SOP and rotated 8-lead SOP package.

■ Connection Diagram

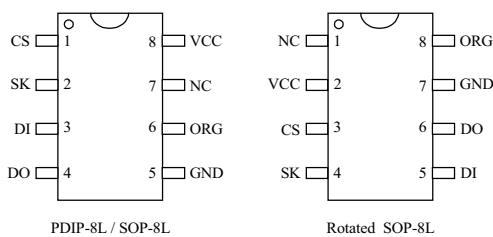

■ Pin Descriptions

CS	Chip Select
SK	Serial Data Clock
DI	Serial Data Input
DO	Serial Data Output
GND	Ground
VCC	Power Supply
NC	No Connection
ORG	Internal Organization

■ Ordering Information

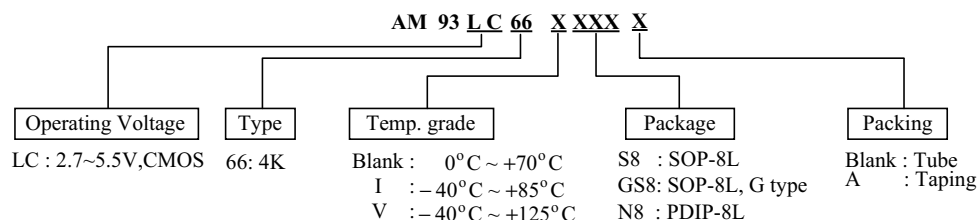

This datasheet contains new product information. Analog Technology reserves the rights to modify the product specification without notice. No liability is assumed as a result of the use of this product. No rights under any patent accompany the sale of the product.

AM93LC66



4096-bits Serial CMOS Electrically Erasable PROM

■ Block Diagram

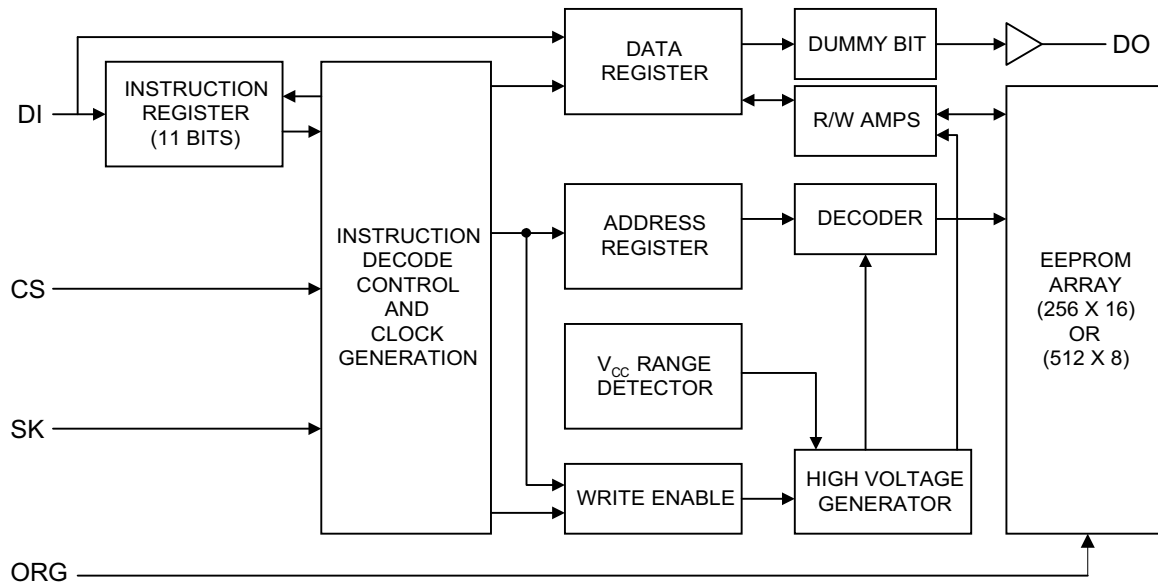

■ Absolute Maximum Ratings

Storage Temperature.....-65°C to + 125°C
 Voltage with Respect to Ground.....-0.3 to + 6.5 V

NOTE: These are STRESS rating only. Appropriate conditions for operating these devices given elsewhere may permanently damage the part. Prolonged exposure to maximum ratings may affect device reliability.

■ Operating Conditions

Temperature under bias: AM93LC66 0°C to + 70°C
 AM93LC66I -40°C to + 85°C
 AM93LC66V..... -40°C to + 125°C

■ DC Electrical Characteristics (V_{cc} = 2.7~5.5V, T_a = 25°C, unless otherwise noted)

Symbol	Parameter	Conditions	AM93LC66		Units
			Min	Max	
I _{CC1}	Operating Current (Program)	SCL = 100KHZ CMOS Input Levels	—	3	mA
I _{CC2}	Operating Current (Read)	SCL = 100KHZ CMOS Input Levels	—	200	μA
I _{SB1}	Standby Current	SCL=SDA=0V, V _{cc} =5V	—	10	μA
I _{SB2}	Standby Current	SCL=SDA=0V, V _{cc} =3V	—	1	
I _{IL}	Input Leakage	V _{IN} = 0 V to V _{CC}	-1	+1	μA
I _{OL}	Output Leakage	V _{OUT} = 0 V to V _{cc}	-1	+1	μA
V _{IL}	Input Low Voltage**		-0.1	V _{cc} x 0.3	V
V _{IH}	Input High Voltage**		V _{cc} x 0.7	V _{cc} + 0.2	V
V _{OL1}	Output Low Voltage	I _{OL} = 2.1mA TTL	—	0.4	V
V _{OL2}	Output Low Voltage	I _{OL} = 10uA CMOS	—	0.2	V
V _{LK}	V _{CC} Lockout Voltage	Programming command can be Executed	Default	—	V

Note. ** V_{IL} min and V_{IH} max are reference only and are not tested

AM93LC66

4096-bits Serial CMOS Electrically Erasable PROM



AC Electrical Characteristics (V_{CC} = 2.7V ~ 5.5V, T_a = 25°C, unless otherwise noted)

Symbol	Parameter	Conditions	AM93LC66		Units
			Min	Max	
F _{SK}	SK Clock Frequency		0	1	MHz
T _{SKH}	SK High Time		250		ns
T _{SKL}	SK Low Time		250		ns
T _{CS}	Minimum CS Low Time		250		ns
T _{CSS}	CS Setup Time	Relative to SK	50		ns
T _{DIS}	DI Setup Time	Relative to SK	100		ns
T _{cSH}	CS Hold Time	Relative to SK	0		ns
T _{DIH}	DI Hold Time	Relative to SK	100		ns
T _{pD1}	Output Delay to "1"	AC Test		500	ns
T _{pD0}	Output Delay to "0"	AC Test		500	ns
T _{SV}	CS to Status Valid	AC Test CL = 100pF		500	ns
T _{dF}	CS to DO in 3-state	CS = VIL		100	ns
T _{wP}	Write Cycle Time			10	ms
Endurance**	5V, 25°C, Page Mode		1M		write cycles

Note. ** The parameter is characterized and isn't 100% tested.

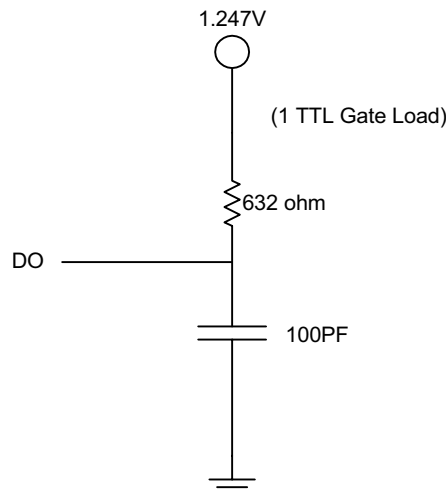

FIGURE 1. AC TEST CONDITIONS

Instruction Set

Instruction	Start Bit	OP Code	Address		Input Data	
			× 8	× 16	× 8	× 16
READ	1	10	A ₈ - A ₀	A ₇ - A ₀		
WEN (Write Enable)	1	00	11 XXXXXXXX	11 XXXXXXXX		
WRITE	1	01	A ₈ - A ₀	A ₇ - A ₀	D ₇ - D ₀	D ₁₅ - D ₀
WRALL (Write All Registers)	1	00	01 XXXXXXXX	01 XXXXXXXX	D ₇ - D ₀	D ₁₅ - D ₀
WDS (Write Disable)	1	00	00 XXXXXXXX	00 XXXXXXXX		
ERASE	1	11	A ₈ - A ₀	A ₇ - A ₀		
ERAL (Erase All Registers)	1	00	40 XXXXXXXX	10 XXXXXXXX		

AM93LC66

4096-bits Serial CMOS Electrically Erasable PROM



■ Pin Capacitance ** ($T_a=25^\circ\text{C}$, $f=1\text{MHz}$)

Symbol	Parameter	Max	Units
C_{OUT}	Output capacitance	5	pF
C_{IN}	Input capacitance	5	pF

Note. ** The parameter is characterized and isn't 100% tested.

■ Functional Description

Applications

The AM93LC66 is ideal for high volume applications requiring low power and low density storage. This device uses a low cost, space saving 8-pin package. Typical applications include robotics, alarm devices, electronic locks, meters and instrumentation settings such as LAN cards, monitors and MODEM.

Endurance and Data Retention

The AM93LC66 is designed for applications requiring up to 1M programming cycles (WRITE, WRALL, EARSE and ERALL). It provides 40 years of secure data retention.

Device Operation

The AM93LC66 is controlled by seven 13-bit instructions. Instructions are clocked in (serially) on the DI pin. Each instruction begins with a logical "1" (the start bit). This is followed by the opcode (2 bits), the address field (8 bits), and data, if appropriate. The clock signal (SK) may be halted at any time and the AM93LC66 will remain in its last state. This allows full static flexibility and maximum power conservation.

Read (READ)

The READ instruction is the only instruction that outputs serial data on the DO pin. After the read instruction and address have been decoded, data is transferred from the selected memory register into a 8-bit or 16-bit serial shift register. (Please note that one logical "0" bit precedes the actual 8-bit or 16-bit output data string.) The output on DO changes during the rising edge transitions of SK. (Shown in Figure 3)

Auto Increment Read Operations

Sequential read is possible, since the AM93LC66 has been designed to output a continuous stream of memory content in response to a single read operation instruction. To utilize this function, the system asserts a read instruction specifying a start location address. Once the 8-bit or 16-bit of the addressed word have been clocked out, the data in consecutively higher address locations is output. The address will wrap around continuously with CS high until the chip select (CS) control pin is brought low. This allows for single instruction data dumps to be executed with a minimum of firmware overhead.

Write Enable (WEN)

Before any device programming (WRITE, WRALL, ERASE, and ERAL) can be done, the WRITE ENABLE (WEN) instruction must be executed first. When V_{cc} is applied, this device powers up in the WRITE DISABLE state. The device then remains in a WRITE DISABLE state until a WEN instruction is executed. Thereafter the device remains enabled until a WDS instruction is executed or until V_{cc} is removed. (NOTE: Neither the WEN nor the WDS instruction has any effect on the READ instruction.) (Shown in Figure 4)

Write Disable (WDS)

The WRITE DISABLE (WDS) instruction disables all programming capabilities. This protects the entire part against accidental modification of data until a WEN instruction is executed. (When V_{cc} is applied, this part powers up in the WRITE DISABLE state.) To protect data, a WDS instruction should be executed upon completion of each programming operation. (NOTE: Neither the WEN nor the WDS instruction has any effect on the READ instruction.) (Shown in Figure 5)

■ Functional Descriptions (Continued)

Write (WRITE)

The WRITE instruction includes 8-bit or 16-bit of data to be written into the specified register. After the last data bit has been applied to DI, and before the next rising edge of SK, CS must be brought LOW. The falling edge of CS initiates the self-timed programming cycle.

After a minimum wait of 250ns (5V operation) from the falling edge of CS (tcs), DO will indicate the READY/BUSY status of the chip if CS is brought HIGH. This means that logical "0" implies the programming is still in progress while logical "1" indicates the selected register has been written, and the part is ready for another instruction. (See Figure 6)

NOTE: The combination of CS HIGH, DI HIGH and the rising edge of the SK clock, resets the READY/BUSY flag. Therefore, it is important if you want to access the READY/BUSY flag, not to reset it through this combination of control signals.

Before a WRITE instruction can be executed, the device must be in the WRITE ENABLE (WEN) state.

Write All (WRALL)

The Write All (WRALL) instruction programs all registers with the data pattern specified in the instruction. While the WRALL instruction is being loaded, the address field becomes a sequence of DON'T-CARE bits. (Shown in Figure 7)

As with the WRITE instruction, if CS is brought HIGH after a minimum wait of 250ns (tcs), the DO pin indicates the READY/BUSY status of the chip. (Shown in Figure 7)

Erase (ERASE)

After the erase instruction is entered, CS must be brought LOW. The falling edge of CS initiates the self-timed internal programming cycle. Bringing CS HIGH after minimum of tcs, will cause DO to indicate the READ/BUSY status of the chip. To explain this, a logical "0" indicates the programming is still in progress while a logical "1" indicates the erase cycle is complete and the part is ready for another instruction. (Shown in Figure 8)

Erase All (ERALL)

Full chip erase is provided for ease of programming. Erasing the entire chip involves setting all bits in the entire memory array to a logical "1". (Shown in Figure 9)

Security Consideration

To protect the entire part against accidental modification of data, each programming instruction (WRITE, WRALL, ERASE, and ERALL) must satisfy two conditions before user initiate self-timed programming cycle (the falling edge of CS). One is that the AM93LC66 is at WEN status. The other is that the VCC value must exceed a lock-out value which can be adjusted by ANALOG TECHNOLOGY INC.

AM93LC66

4096-bits Serial CMOS Electrically Erasable PROM



■ Timing Diagrams (1)

Organization Key

I/O	AM93LC56 (2K)		AM93LC66 (4K)	
	× 8	× 16	× 8	× 16
A _N	A ₈ ⁽¹⁾	A ₇ ⁽²⁾	A ₈	A ₇
D _N	D ₇	D ₁₅	D ₇	D ₁₅

Note: (1). A₈ is a DON'T CARE value, but the extra clock is required.
 (2). A₇ is a DON'T CARE value, but the extra clock is required.

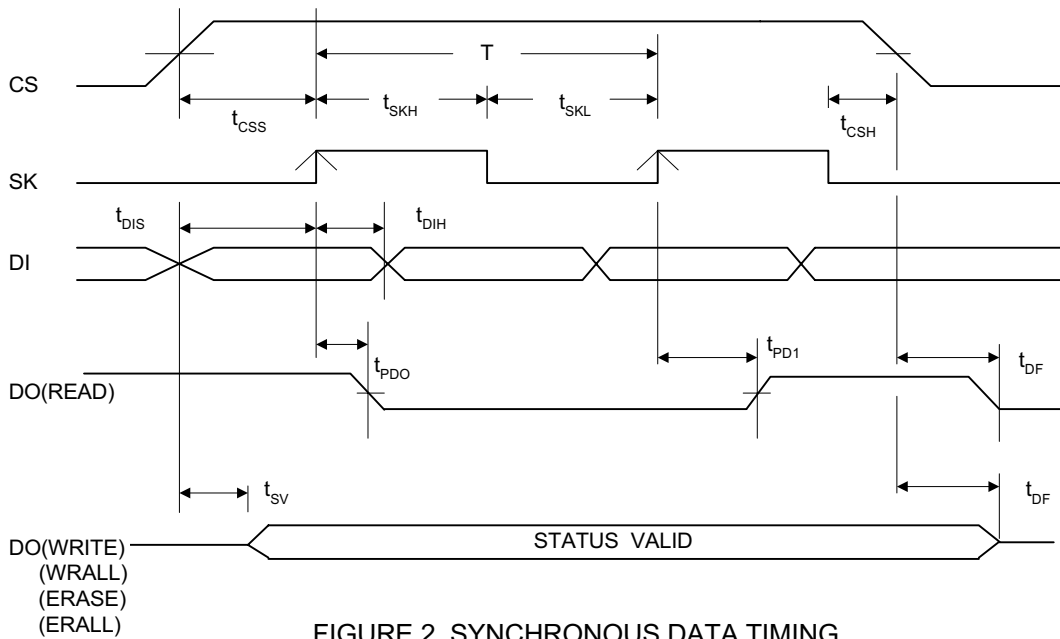
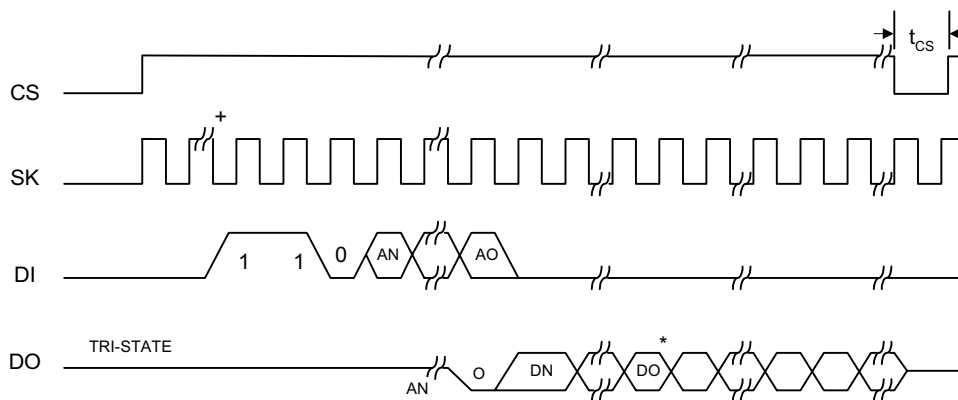

FIGURE 2. SYNCHRONOUS DATA TIMING



+For all instructions, SK cycles before start bit don't care.
 *Address Pointer Cycle to the Next Register.

FIGURE 3. DATA READ CYCLE TIMING

■ Timing Diagrams (2)

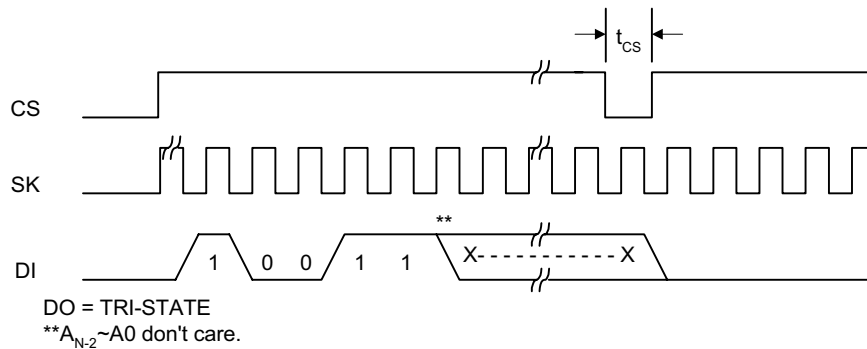

FIGURE 4. WRITE ENABLE(WEN) CYCLE TIMING

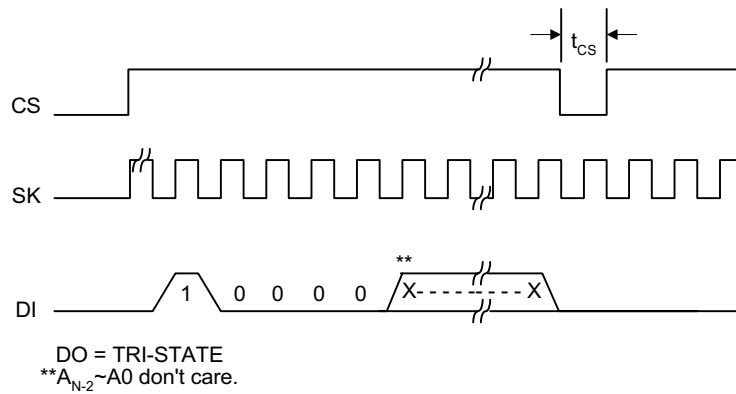

FIGURE 5. WRITE DISABLE(WDS) CYCLE TIMING

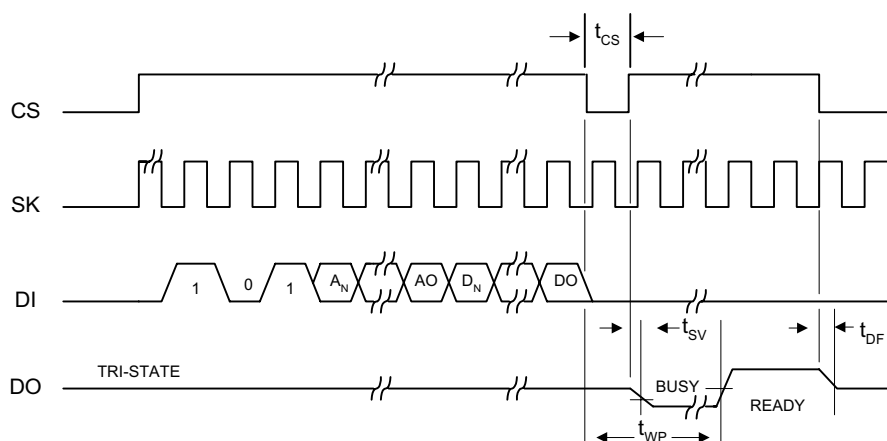

FIGURE 6. WRITE(WRITE) CYCLE TIMING

AM93LC66

4096-bits Serial CMOS Electrically Erasable PROM



■ Timing Diagrams (3)

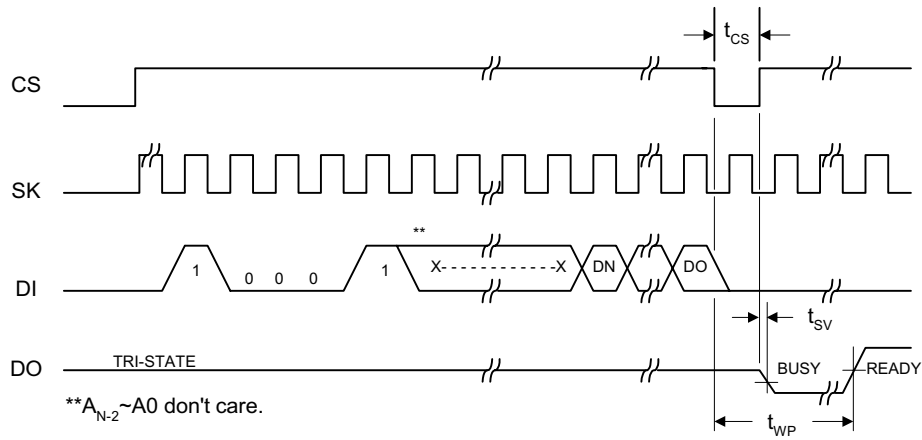

FIGURE 7. WRITE ALL(WRALL) CYCLE TIMING

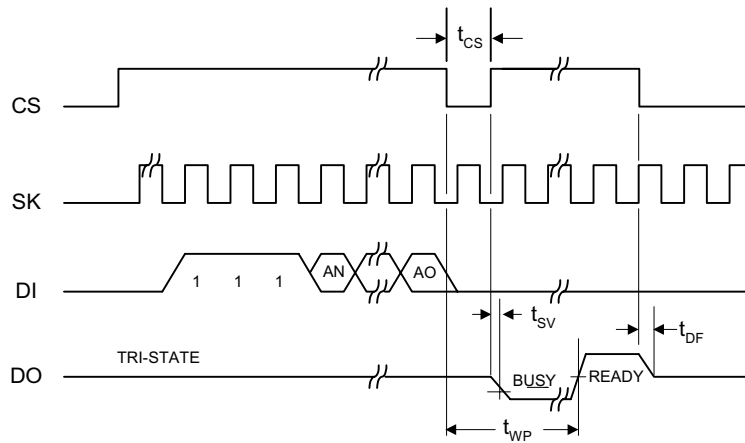

FIGURE 8. ERASE(ERASE) CYCLE TIMING

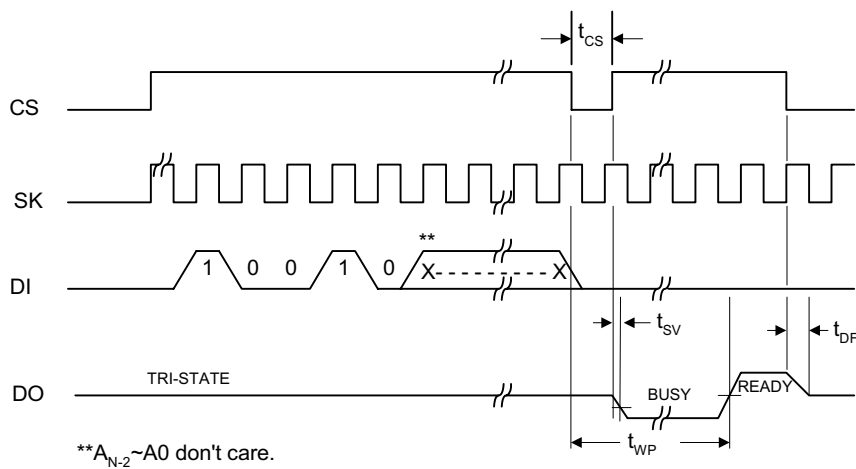

FIGURE 9. ERASE ALL(ERALL) CYCLE TIMING

AM93LC66

4096-bits Serial CMOS Electrically Erasable PROM



■ Package Diagrams

(1) Plastic Dual-in-line Package (PDIP-8L)

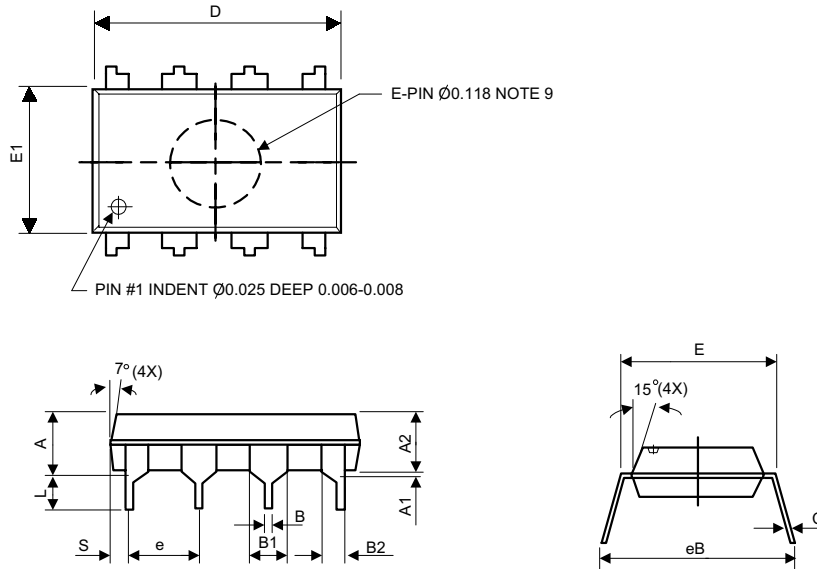

Symbols	Dimensions in millimeters			Dimensions in inches		
	Min.	Nom.	Max.	Min.	Nom.	Max.
A	—	—	5.33	—	—	0.210
A1	0.38	—	—	0.015	—	—
A2	3.1	3.30	3.5	0.122	0.130	0.138
B	0.36	0.46	0.56	0.014	0.018	0.022
B1	1.4	1.52	1.65	0.055	0.060	0.065
B2	0.81	0.99	1.14	0.032	0.039	0.045
C	0.20	0.25	0.36	0.008	0.010	0.014
D	9.02	9.27	9.53	0.355	0.365	0.375
E	7.62	7.94	8.26	0.300	0.313	0.325
E1	6.15	6.35	6.55	0.242	0.250	0.258
e	—	2.54	—	—	0.100	—
L	2.92	3.3	3.81	0.115	0.130	0.150
eB	8.38	8.89	9.40	0.330	0.350	0.370
S	0.71	0.84	0.97	0.028	0.033	0.038

AM93LC66

4096-bits Serial CMOS Electrically Erasable PROM



■ Package Diagrams (Continued)

(2) JEDEC Small Outline Package (SOP-8L)

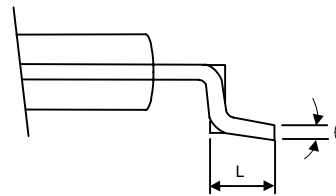
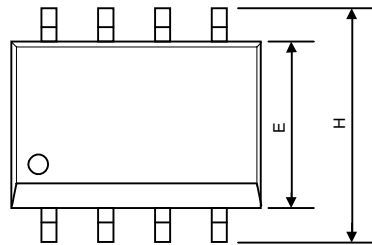

VIEW "A"

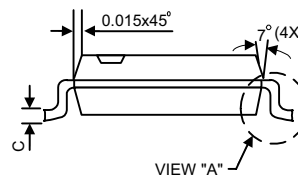
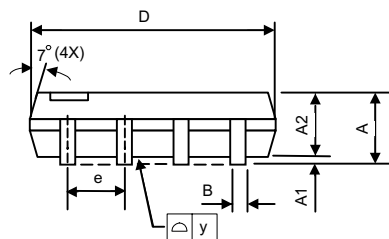

VIEW "A"

Symbols	Dimensions in millimeters			Dimensions in inches		
	MIN	NOM	MAX	MIN	NOM	MAX
A	1.40	1.60	1.75	0.055	0.063	0.069
A1	0.10	—	0.25	0.040	—	0.100
A2	1.30	1.45	1.50	0.051	0.057	0.059
B	0.33	0.41	0.51	0.013	0.016	0.020
C	0.19	0.20	0.25	0.0075	0.008	0.010
D	4.80	4.85	5.05	0.189	0.191	0.199
E	3.80	3.91	4.00	0.150	0.154	0.157
e	—	1.27	—	—	0.050	—
H	5.79	5.99	6.20	0.228	0.236	0.244
L	0.38	0.71	1.27	0.015	0.028	0.050
y	—	—	0.10	—	—	0.004
theta	0°	—	8°	0°	—	8°

■ Marking Information

Part Number (X:ID Code)

Blank : PDIP-8L & SOP-8L (Commercial)

I : PDIP-8L & SOP-8L (Industrial)

V : PDIP-8L & SOP-8L (Automotive)

G : Rotated SOP-8L (Commercial)

B : Rotated SOP-8L (Industrial)

D : Rotated SOP-8L (Automotive)

