



High Performance E² PLD

ATF22V10CZ Preliminary

Features

- Industry Standard Architecture
- 12 ns Maximum Pin-to-Pin Delay
- Zero Power - 25 μ A Maximum Standby Power
- CMOS and TTL Compatible Inputs and Outputs
- Advanced Electrically Erasable Technology
Reprogrammable
100% Tested
- Latch Feature Holds Inputs to Previous Logic State
- High Reliability CMOS Process
20 Year Data Retention
100 Erase/Write Cycles
2,000V ESD Protection
200 mA Latchup Immunity
- Commercial and Industrial Temperature Ranges
- Dual-in-Line and Surface Mount Packages in Standard Pinouts

Block Diagram

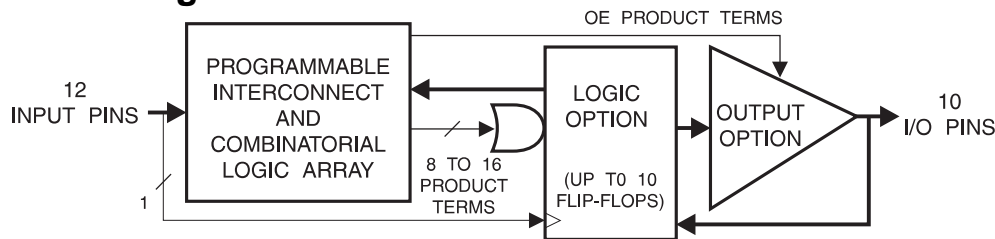

Description

The ATF22V10CZ is a high performance CMOS (Electrically Erasable) Programmable Logic Device (PLD) which utilizes Atmel's proven electrically erasable Flash memory technology. Speeds down to 12 ns with zero standby power dissipation are offered. All speed ranges are specified over the full 5V \pm 10% range for industrial temperature ranges; 5V \pm 5% for commercial range 5-volt devices.

Pin Configurations

Pin Name	Function
CLK	Clock
IN	Logic Inputs
I/O	Bidirectional Buffers
VCC	+5V Supply

TSSOP Top View

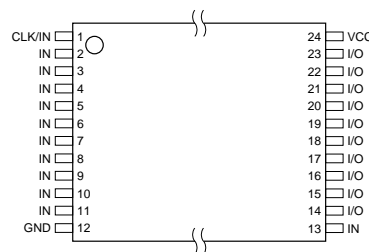

DIP/SOIC

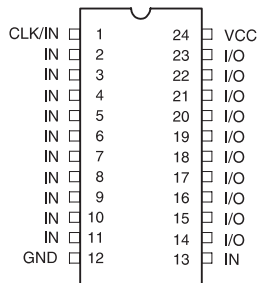

PLCC Top View (1)

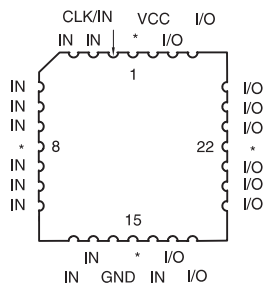

Note: 1. For PLCC, P1, P8, P15 and P22 can be left unconnected. Connect VCC to pin 1 and GND to 8, 15, and 22.





The ATF22V10CZ provides a “zero” power CMOS PLD solution with 5V operating voltages. The ATF22V10CZ powers down automatically to the zero power mode through Atmel’s patented Input Transition Detection (ITD) circuitry when the device is idle. The ATF22V10CZ has an edge-sensing power down feature, offering “zero” (25 μ A worst case) standby power. This feature allows the user to manage total system power to meet specific application requirements and enhance reliability. Pin “keeper”

circuits on input and output pins eliminate static power consumed by pull-up resistors.

The ATF22V10CZ incorporates a superset of the generic architectures, which allows direct replacement of the 22V10 family and most 24-pin combinatorial PLDs. Ten outputs are each allocated 8 to 16 product terms. Three different modes of operation, configured automatically with software, allow highly complex logic functions to be realized.

Absolute Maximum Ratings*

Temperature Under Bias.....	-40°C to +85°C
Storage Temperature.....	-65°C to +150°C
Voltage on Any Pin with Respect to Ground.....	-2.0V to +7.0V ⁽¹⁾
Voltage on Input Pins with Respect to Ground During Programming.....	-2.0V to +14.0V ⁽¹⁾
Programming Voltage with Respect to Ground.....	-2.0V to +14.0V ⁽¹⁾

*NOTICE: Stresses beyond those listed under “Absolute Maximum Ratings” may cause permanent damage to the device. This is a stress rating only and functional operation of the device at these or any other conditions beyond those indicated in the operational sections of this specification is not implied. Exposure to absolute maximum rating conditions for extended periods may affect device reliability.

Note: 1. Minimum voltage is -0.6V dc, which may undershoot to -2.0V for pulses of less than 20 ns. Maximum output pin voltage is $V_{cc} + 0.75V$ dc, which may overshoot to 7.0V for pulses of less than 20 ns.

DC and AC Operating Conditions

	Commercial	Industrial
Operating Temperature (Case)	0°C - 70°C	-40°C - 85°C
V _{CC} Power Supply	5V \pm 5%	5V \pm 10%

Functional Logic Diagram Description

The Functional Logic Diagram describes the ATF22V10CZ architecture.

The ATF22V10CZ has 12 inputs and 10 I/O macrocells. Each macrocell can be configured into one of four output configurations: active high/low, registered/combinatorial output. The universal architecture of the ATF22V10CZ can be programmed to emulate most 24-pin PAL devices.

Unused product terms are automatically disabled by the compiler to decrease power consumption. A Security Fuse, when programmed, protects the contents of the ATF22V10CZ. Eight bytes (64 fuses) of User Signature are accessible to the user for purposes such as storing project name, part number, revision or date. The User Signature is accessible regardless of the state of the Security Fuse.

DC Characteristics

Symbol	Parameter	Condition	Min	Typ	Max	Units
I _{IL}	Input or I/O Low Leakage Current	$0 \leq V_{IN} \leq V_{IL(max)}$			-10	μA
I _{IH}	Input or I/O High Leakage Current	$3.5 \leq V_{IN} \leq V_{CC}$			10	μA
I _{CC}	Clocked Power Supply Current	V _{CC} = MAX, Outputs Open, f = 15 MHz	Com. Ind.	90 90	150 180	mA mA
I _{SB}	Power Supply Current, Standby	V _{CC} = MAX, V _{IN} = MAX, Outputs Open	Com. Ind.	5 5	25 50	μA μA
I _{OS} (1)	Output Short Circuit Current	V _{OUT} = 0.5V			-150	mA
V _{IL}	Input Low Voltage		-0.5		0.8	V
V _{IH}	Input High Voltage		2.0		V _{CC} + 0.75	V
V _{OL}	Output Low Voltage	V _{IN} = V _{IH} or V _{IL} V _{CC} = MIN, I _{OL} = 16 mA	Com. Ind.		0.5	V
V _{OH}	Output High Voltage	V _{IN} = V _{IH} or V _{IL} , V _{CC} = MIN, I _{OH} = -4.0 mA		2.4		V

Note: 1. Not more than one output at a time should be shorted. Duration of short circuit test should not exceed 30 sec.

AC Waveforms

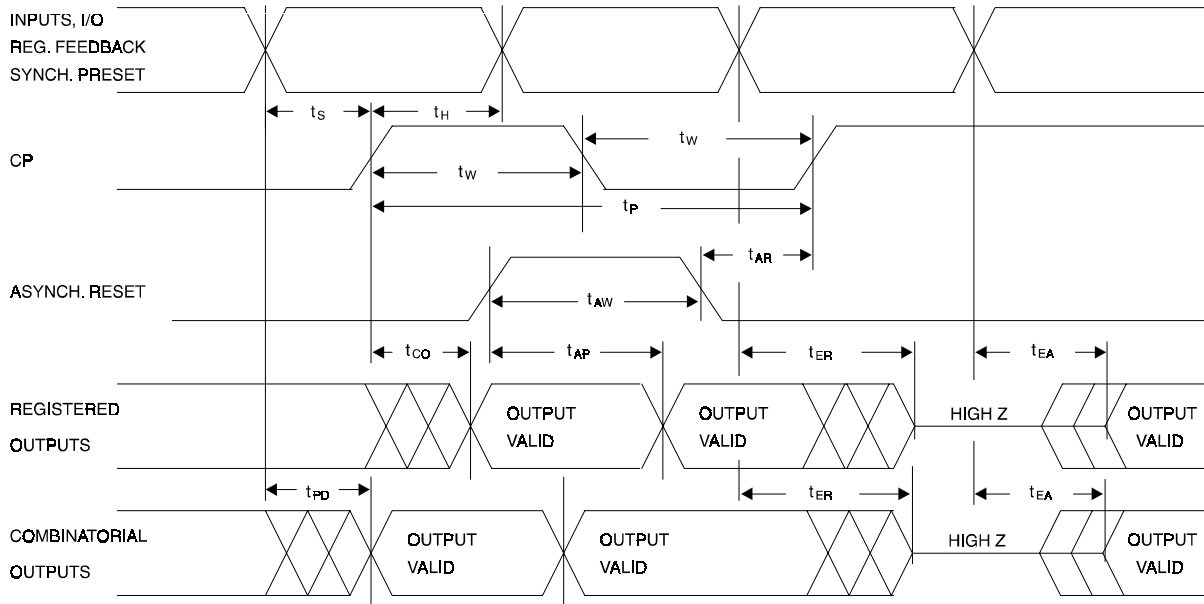

AC Characteristics ⁽¹⁾

Symbol	Parameter	-12		-15		Units
		Min	Max	Min	Max	
t _{PD}	Input to Feedback to Non-Registered Output	3	12	3	15	ns
t _{CF}	Clock to Feedback		6		4.5	ns
t _{CO}	Clock to Output	2	8	2	8	ns
t _S	Input or Feedback Setup Time	10		10		ns
t _H	Input Hold Time	0		0		ns
t _P	Clock Period	12		12		ns
t _W	Clock Width	6		6		ns
F _{MAX}	External Feedback 1/(t _S + t _{CO})		55.5	55.5		MHz
	Internal Feedback 1/(t _S + t _{CF})		62	69		MHz
	No Feedback 1/(t _P)		83.3	83.3		MHz
t _{EA}	Input to Output Enable - Product Term	3	12	3	15	ns
t _{ER}	Input to Output Disable - Product Term	2	15	3	15	ns
t _{PZX}	OE Pin to Output Enable	2	12	2	15	ns
t _{PXZ}	OE Pin to Output Disable	2	15	2	15	ns
t _{AP}	Input or I/O to Asynchronous Reset of Register	3	10	3	15	ns
t _{SP}	Setup Time, Synchronous Preset	10		10		ns
t _{AW}	Asynchronous Reset Width	7		8		ns
t _{AR}	Asynchronous Reset Recovery Time	5		6		ns
t _{SPR}	Synchronous Preset to Clock Recovery Time	10		10		ns

Note: 1. See ordering information for valid part numbers.

Input Test Waveforms and Measurement Levels

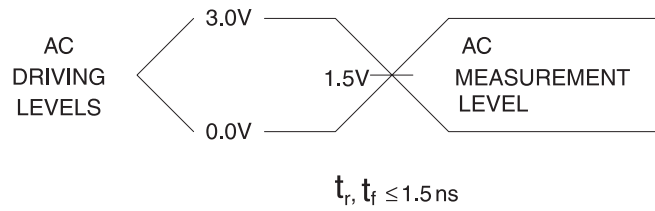

Output Test Loads

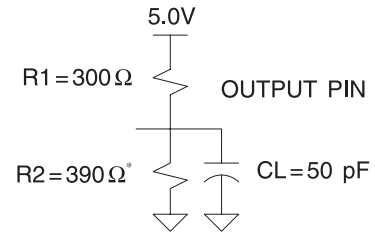

Note: Similar competitors' devices are specified with slightly different loads. These load differences may affect output signals' delay and slew rate. Atmel devices are tested with sufficient margins to meet compatible device specification conditions.

Pin Capacitance (f = 1 MHz, T = 25°C) ⁽¹⁾

	Typ	Max	Units	Conditions
C _{IN}	5	8	pF	V _{IN} = 0V
C _{OUT}	6	8	pF	V _{OUT} = 0V

Note: 1. Typical values for nominal supply voltage. This parameter is only sampled and is not 100% tested.

Power Up Reset

The registers in the ATF22V10CZ are designed to reset during power up. At a point delayed slightly from V_{CC} crossing V_{RST} , all registers will be reset to the low state. The output state will depend on the polarity of the buffer.

This feature is critical for state machine initialization. However, due to the asynchronous nature of reset and the uncertainty of how V_{CC} actually rises in the system, the following conditions are required:

1. The V_{CC} rise must be monotonic and start below 0.7V.
2. The clock must remain stable during T_{PR} .
3. After T_{PR} occurs, all input and feedback setup times must be met before driving the clock pin high.

Preload of Register Outputs

The ATF22V10CZ's registers are provided with circuitry to allow loading of each register with either a high or a low. This feature will simplify testing since any state can be forced into the registers to control test sequencing. A JEDEC file with preload is generated when a source file with vectors is compiled. Once downloaded, the JEDEC

file preload sequence will be done automatically by most of the approved programmers after the programming.

Electronic Signature Word

There are 64 bits of programmable memory that are always available to the user, even if the device is secured. These bits can be used for user-specific data.

Security Fuse Usage

A single fuse is provided to prevent unauthorized copying of the ATF22V10CZ fuse patterns. Once programmed, fuse verify and preload are inhibited. However, the 64-bit User Signature remains accessible. The security fuse should be programmed last, as its effect is immediate.

Programming/Erasing

Programming/erasing is performed using standard PLD programmers. See CMOS PLD Programming Hardware & Software Support for information on software/programming.

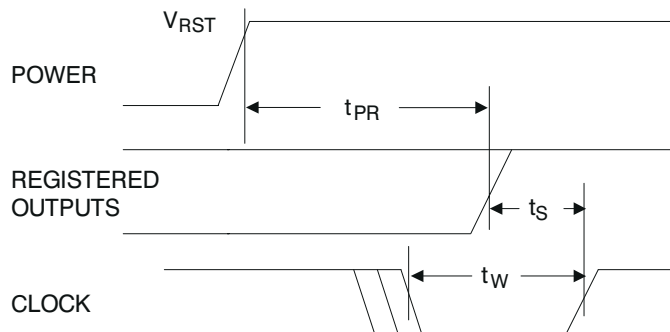

Parameter	Description	Typ	Max	Units
T_{PR}	Power-Up Reset Time	600	1,000	ns
V_{RST}	Power-Up Reset Voltage	3.8	4.5	V

Input and I/O Pull-Ups

All ATF22V10CZ family members have internal input and I/O pin-keeper circuits. Therefore, whenever inputs or I/Os are not being driven externally, they will maintain their last driven state. This ensures that all logic array inputs

and device outputs are at known states. These are relatively weak active circuits that can be easily overridden by TTL-compatible drivers (see input and I/O diagrams below).

Input Diagram

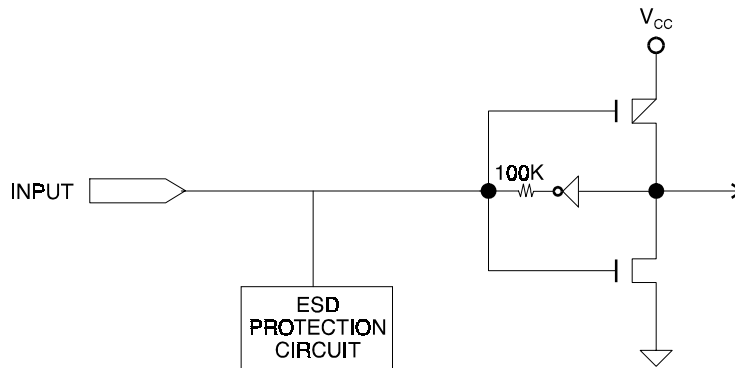

I/O Diagram

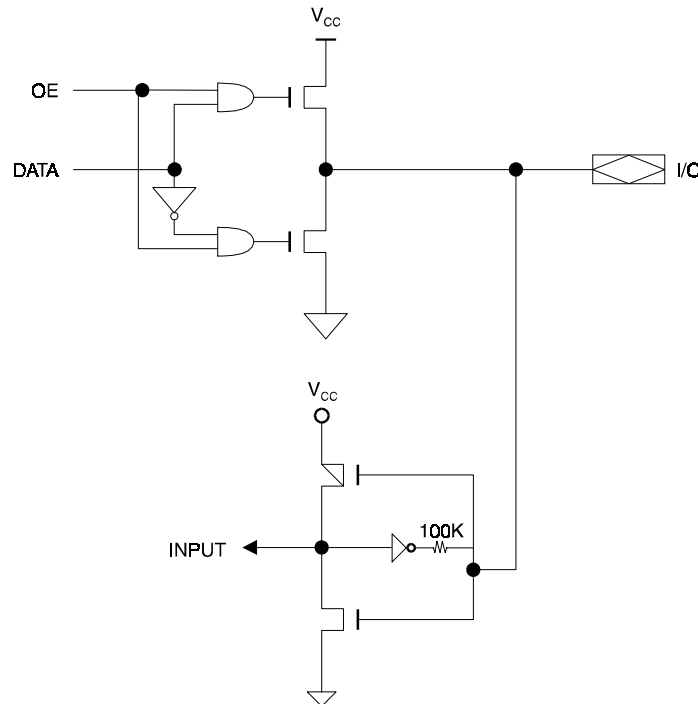

Functional Logic Diagram ATF22V10CZ

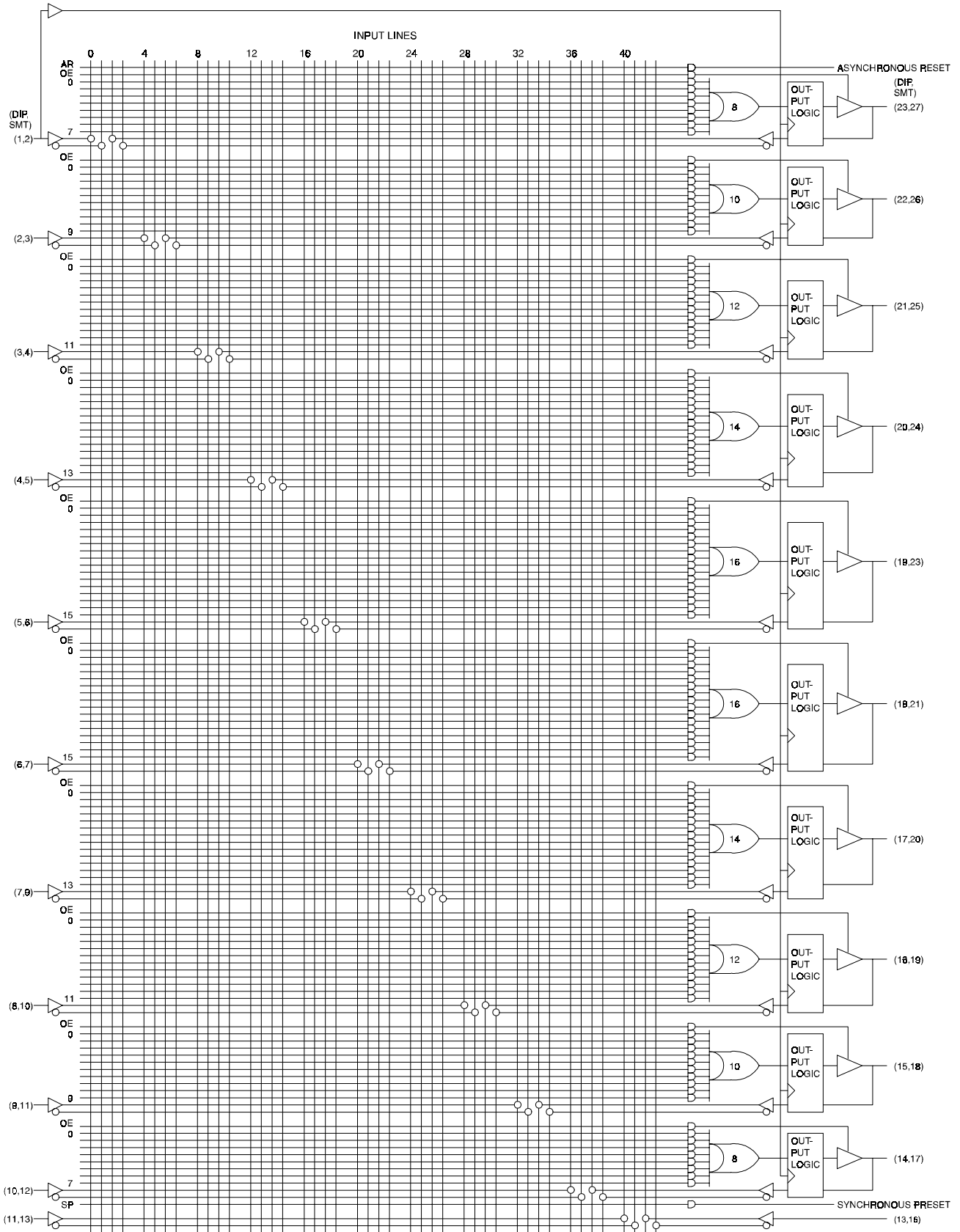

tpD (ns)	ts (ns)	tco (ns)	Ordering Code	Package	Operation Range
12	10	8	ATF22V10CZ-12JC	28J	Commercial (0°C to 70°C)
			ATF22V10CZ-12PC	24P3	
			ATF22V10CZ-12SC	24S	
			ATF22V10CZ-12XC	24X	
15	4.5	8	ATF22V10CZ-15JC	28J	Commercial (0°C to 70°C)
			ATF22V10CZ-15PC	24P3	
			ATF22V10CZ-15SC	24S	
			ATF22V10CZ-15XC	24X	
	4.5	8	ATF22V10CZ-15JI	28J	Industrial (-40°C to +85°C)
			ATF22V10CZ-15PI	24P3	
			ATF22V10CZ-15SI	24S	
			ATF22V10CZ-15XI	24X	

Package Type	
28J	28-Lead, Plastic J-Leaded Chip Carrier (PLCC)
24P3	24-Lead, 0.300" Wide, Plastic Dual Inline Package (DIP)
24S	24-Lead, 0.300" Wide, Plastic Gull Wing Small Outline (SOIC)
24X	24-Lead, 4.4 mm Wide, Plastic Thin Shrink Small Outline (TSSOP)