

Features

- Fast Read Access Time - 70 ns
- Word-wide or Byte-wide Configurable
- 4 Megabit Flash and Mask ROM Compatible
- Low Power CMOS Operation
 - 100 μ A Maximum Standby
 - 50 mA Maximum Active at 5 MHz
- Wide Selection of JEDEC Standard Packages
 - 40-Lead 600 mil PDIP
 - 40-Lead SOIC (SOP)
 - 48-Lead TSOP (12 mm x 20 mm)
- 5V \pm 10% Power Supply
- High Reliability CMOS Technology
 - 2,000V ESD Protection
 - 200 mA Latchup Immunity
- Rapid™ Programming Algorithm - 50 μ s/word (typical)
- CMOS and TTL Compatible Inputs and Outputs
- Integrated Product Identification Code
- Commercial and Industrial Temperature Ranges

Description

The AT27C400 is a low-power, high-performance 4,194,304-bit one-time programmable read only memory (OTP EPROM) organized as either 256K by 16 or 512K by 8 bits. It requires a single 5V power supply in normal read mode operation. Any word can be accessed in less than 70 ns, eliminating the need for speed-reducing WAIT states. The by-16 organization makes this part ideal for high-performance 16- and 32-bit microprocessor systems.

Pin Configurations

Pin Name	Function
A0 - A17	Addresses
O0 - O15	Outputs
O15/A-1	Output/Address
BYTE/VPP	Byte Mode/ Program Supply
\overline{CE}	Chip Enable
\overline{OE}	Output Enable
NC	No Connect

Note: Both GND pins must be connected.

PDIP Top View

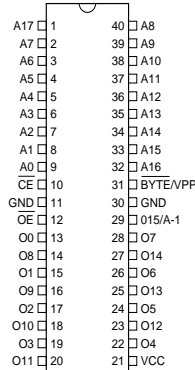

SOIC (SOP)

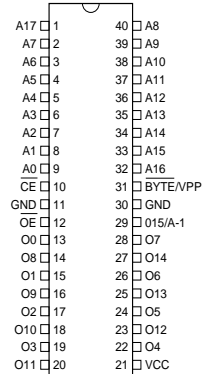

TSOP
Type 1

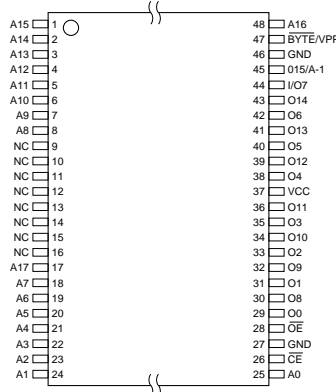

4-Megabit (256K x 16 or 512K x 8) OTP EPROM

AT27C400

Preliminary



Description (Continued)

The AT27C400 can be organized as either word-wide or byte-wide. The organization is selected via the $\overline{\text{BYTE}}/V_{\text{PP}}$ pin. When $\overline{\text{BYTE}}/V_{\text{PP}}$ is asserted high (V_{IH}), the word-wide organization is selected and the O15/A-1 pin is used for O15 data output. When $\overline{\text{BYTE}}/V_{\text{PP}}$ is asserted low (V_{IL}), the byte-wide organization is selected and the O15/A-1 pin is used for the address pin A-1. When the AT27C400 is logically regarded as x16 (word-wide), but read in the byte-wide mode, then with $A-1 = V_{\text{IL}}$ the lower 8 bits of the 16-bit word are selected and with $A-1 = V_{\text{IH}}$ the upper 8 bits of the 16-bit word are selected.

In read mode, the AT27C400 typically consumes 15 mA. Standby mode supply current is typically less than 10 μA .

The AT27C400 is available in industry standard JEDEC-approved one-time programmable (OTP) PDIP, SOIC (SOP), and TSOP packages. The device features two-line control ($\overline{\text{CE}}$, $\overline{\text{OE}}$) to eliminate bus contention in high-speed systems.

With high density 256K word or 512K byte storage capability, the AT27C400 allows firmware to be stored reliably and to be accessed by the system without the delays of mass storage media.

Atmel's AT27C400 has additional features that ensure high quality and efficient production use. The Rapid™ Programming Algorithm reduces the time required to program the part and guarantees reliable programming. Programming time is typically only 50 $\mu\text{s}/\text{word}$. The Integrated Product Identification Code electronically identifies the device and manufacturer. This feature is used by industry standard programming equipment to select the proper programming algorithms and voltages.

System Considerations

Switching between active and standby conditions via the Chip Enable pin may produce transient voltage excursions. Unless accommodated by the system design, these transients may exceed data sheet limits, resulting in device non-conformance. At a minimum, a 0.1 μF high frequency, low inherent inductance, ceramic capacitor should be utilized for each device. This capacitor should be connected between the V_{CC} and Ground terminals of the device, as close to the device as possible. Additionally, to stabilize the supply voltage level on printed circuit boards with large EPROM arrays, a 4.7 μF bulk electrolytic capacitor should be utilized, again connected between the V_{CC} and Ground terminals. This capacitor should be positioned as close as possible to the point where the power supply is connected to the array.

Block Diagram

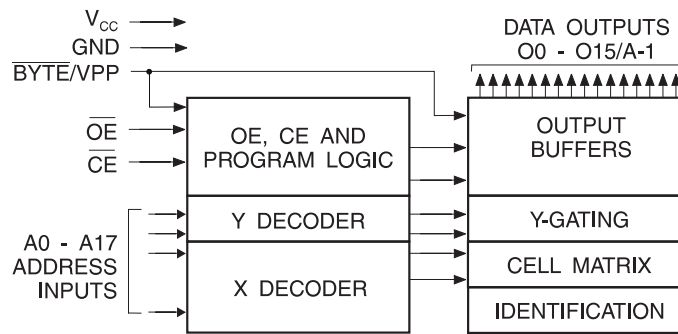

Absolute Maximum Ratings*

Temperature Under Bias	-55°C to +125°C
Storage Temperature.....	-65°C to +150°C
Voltage on Any Pin with Respect to Ground	-2.0V to +7.0V ⁽¹⁾
Voltage on A9 with Respect to Ground	-2.0V to +14.0V ⁽¹⁾
V _{PP} Supply Voltage with Respect to Ground	-2.0V to +14.0V ⁽¹⁾
Integrated UV Erase Dose.....	7258 W •sec/cm ²

*NOTICE: Stresses beyond those listed under “Absolute Maximum Ratings” may cause permanent damage to the device. This is a stress rating only and functional operation of the device at these or any other conditions beyond those indicated in the operational sections of this specification is not implied. Exposure to absolute maximum rating conditions for extended periods may affect device reliability.

Note: 1. Minimum voltage is -0.6V dc which undershoot to -2.0V for pulses of less than 20 ns. Maximum output pin voltage is V_{CC} + 0.75V dc which may overshoot to +7.0V for pulses of less than 20 ns.

Operating Modes

Mode/Pin	CE	OE	Ai	BYTE/V _{PP}	Outputs		
					O ₀ - O ₇	O ₈ - O ₁₄	O ₁₅ /A-1
Read Word-wide	V _{IL}	V _{IL}	X ⁽¹⁾	V _{IH}	D _{OUT}	D _{OUT}	D _{OUT}
Read Byte-wide Upper	V _{IL}	V _{IL}	X ⁽¹⁾	V _{IL}	D _{OUT}	High Z	V _{IH}
Read Byte-wide Lower	V _{IL}	V _{IL}	X ⁽¹⁾	V _{IL}	D _{OUT}	High Z	V _{IL}
Output Disable	X ⁽¹⁾	V _{IH}	X ⁽¹⁾	X		High Z	
Standby	V _{IH}	X ⁽¹⁾	X ⁽¹⁾	X ⁽⁵⁾		High Z	
Rapid Program ⁽²⁾	V _{IL}	V _{IH}	Ai	V _{PP}		D _{IN}	
PGM Verify	X	V _{IL}	Ai	V _{PP}		D _{OUT}	
PGM Inhibit	V _{IH}	V _{IH}	X ⁽¹⁾	V _{PP}		High Z	
Product Identification ⁽⁴⁾	V _{IL}	V _{IL}	A9 = V _H ⁽³⁾ A0 = V _{IH} or V _{IL} A1 - A17 = V _{IL}	V _{IH}		Identification Code	

- Notes:
- X can be V_{IL} or V_{IH}.
 - Refer to the programming characteristics tables in this data sheet.
 - V_H = 12.0 ± 0.5V.
 - Two identifier words may be selected. All inputs are held low (V_{IL}), except A9, which is set to V_H, and A0, which is toggled low (V_{IL}) to select the Manufacturer's Identification word and high (V_{IH}) to select the Device Code word.
 - Standby V_{CC} current (ISB) is specified with V_{PP} = V_{CC}. V_{CC} > V_{PP} will cause a slight increase in ISB.

DC and AC Operating Conditions for Read Operation

		AT27C400			
		-70	-90	-12	-15
Operating Temperature (Case)	Com.	0°C - 70°C	0°C - 70°C	0°C - 70°C	0°C - 70°C
	Ind.	-40°C - 85°C	-40°C - 85°C	-40°C - 85°C	-40°C - 85°C
V _{CC} Power Supply		5V ± 10%	5V ± 10%	5V ± 10%	5V ± 10%

DC and Operating Characteristics for Read Operation

Symbol	Parameter	Condition	Min	Max	Units
I _{LI}	Input Load Current	V _{IN} = 0V to V _{CC}		± 1	μA
I _{LO}	Output Leakage Current	V _{OUT} = 0V to V _{CC}		± 5	μA
I _{PP1} ⁽²⁾	V _{PP} ⁽¹⁾ Read/Standby Current	V _{PP} = V _{CC}		10	μA
I _{SB}	V _{CC} ⁽¹⁾ Standby Current	I _{SB1} (CMOS) CE = V _{CC} ± 0.3V		100	μA
		I _{SB2} (TTL) CE = 2.0 to V _{CC} + 0.5V		1	mA
	V _{CC} Active Current	f = 5 MHz, I _{OUT} = 0 mA, CE = V _{IL}		40	mA
V _{IL}	Input Low Voltage		-0.6	0.8	V
V _{IH}	Input High Voltage		2.0	V _{CC} + 0.5	V
V _{OL}	Output Low Voltage	I _{OL} = 2.1 mA		0.4	V
V _{OH}	Output High Voltage	I _{OH} = -400 μA	2.4		V

- Notes: 1. V_{CC} must be applied simultaneously or before V_{PP} and removed simultaneously or after V_{PP}
 2. V_{PP} may be connected directly to V_{CC}, except during programming. The supply current would then be the sum of I_{CC} and I_{PP}

AC Characteristics for Read Operation

Symbol	Parameter	Condition	AT27C400								Units
			-70		-90		-12		-15		
			Min	Max	Min	Max	Min	Max	Min	Max	
t _{ACC} ⁽²⁾	Address to Output Delay	CE = OE = V _{IL}		70		90		120		150	ns
t _{CE} ⁽²⁾	CE to Output Delay	OE = V _{IL}		70		90		120		150	ns
t _{OE} ⁽²⁾⁽³⁾	OE to Output Delay	CE = V _{IL}		30		35		40		50	ns
t _{DF} ⁽⁴⁾⁽⁵⁾	OE or CE High to Output Float, whichever occurred first			20		20		30		35	ns
t _{OH} ⁽⁴⁾	Output Hold from Address, CE or OE, whichever occurred first		5		5		5		5		ns
t _{ST}	BYTE High to Output Valid			70		90		120		150	ns
t _{STD}	BYTE Low to Output Transition			40		40		50		60	ns

- Notes: 2, 3, 4, 5. See the AC Waveforms for Read Operation diagram.



= Advance Information

Byte-Wide Read Mode AC Waveforms

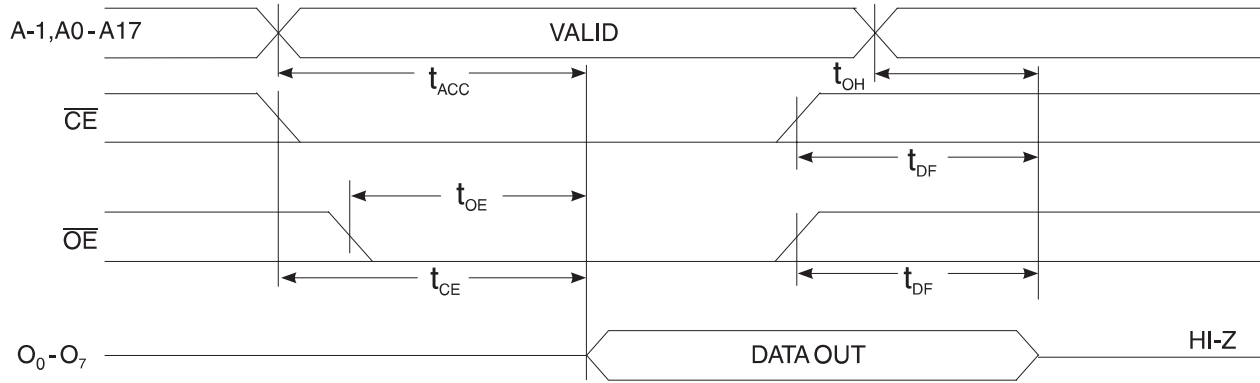

Note: $BYTE/V_{PP} = V_{IL}$

Word-Wide Read Mode AC Waveforms

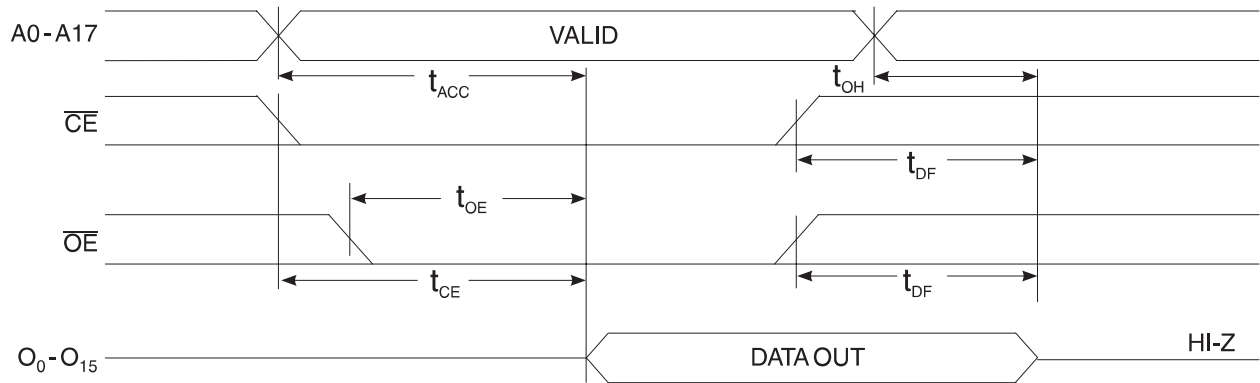

Note: $BYTE/V_{PP} = V_{IH}$

BYTE Transition AC Waveforms

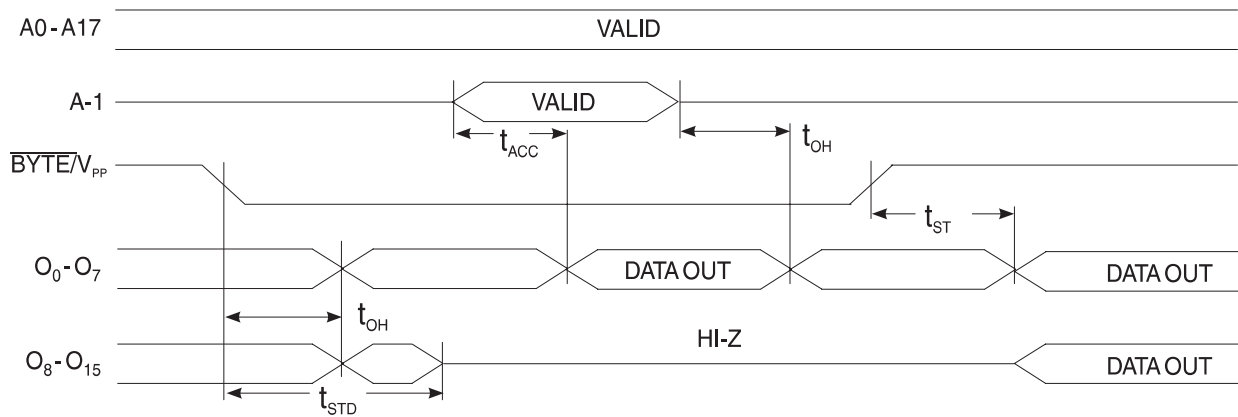

- Notes:
1. Timing measurement references are 0.8V and 2.0V. Input AC drive levels are 0.45V and 2.4V, unless otherwise specified.
 2. \overline{OE} may be delayed up to $t_{CE} - t_{OE}$ after the falling edge of \overline{CE} without impact on t_{CE} .
 3. \overline{OE} may be delayed up to $t_{ACC} - t_{OE}$ after the address is valid without impact on t_{ACC} .
 4. This parameter is only sampled and is not 100% tested.
 5. Output float is defined as the point when data is no longer driven.

Input Test Waveforms and Measurement Levels

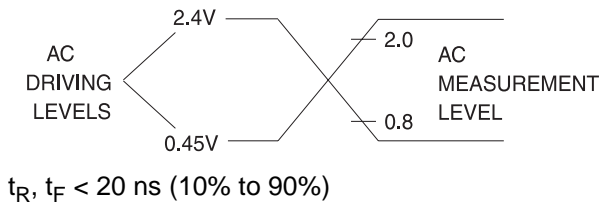

Output Test Load

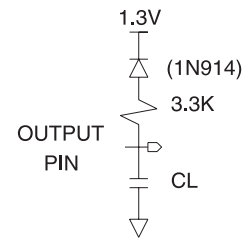

Note: $C_L = 100 \text{ pF}$ including jig capacitance.

Pin Capacitance

($f = 1 \text{ MHz}$ $T = 25^\circ\text{C}$)⁽¹⁾

	Typ	Max	Units	Conditions
C_{IN}	4	10	pF	$V_{IN} = 0V$
C_{OUT}	8	12	pF	$V_{OUT} = 0V$

Note: 1. Typical values for nominal supply voltage. This parameter is only sampled and is not 100% tested.

Programming Waveforms⁽¹⁾

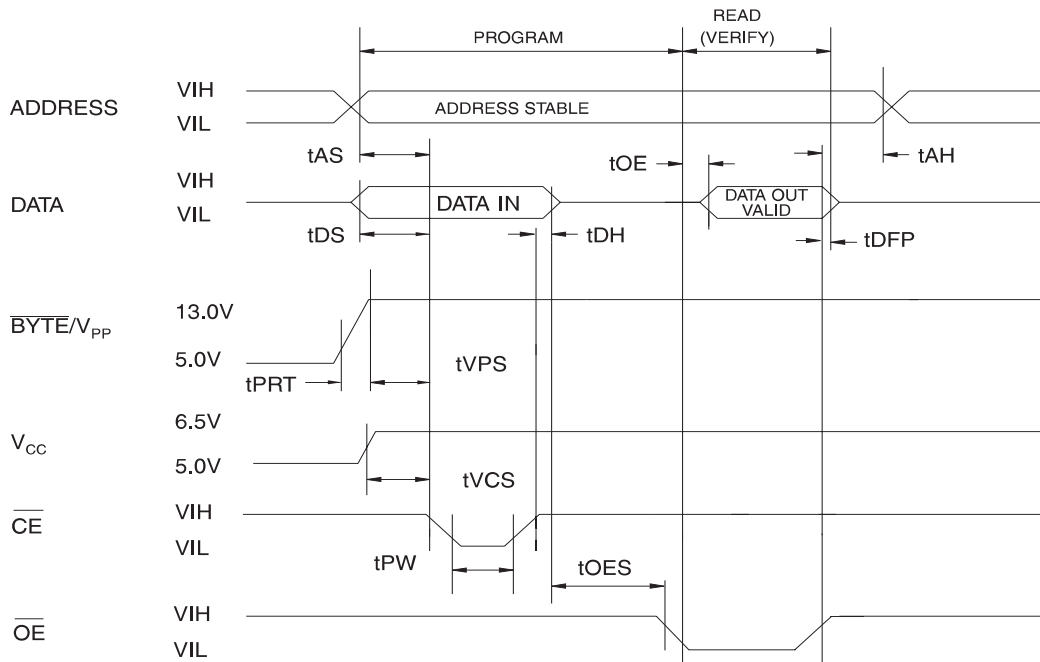

- Notes:
1. The Input Timing Reference is 0.8V for V_{IL} and 2.0V for V_{IH}.
 2. t_{OE} and t_{DFP} are characteristics of the device but must be accommodated by the programmer.
 3. When programming the AT27C400, a 0.1 μF capacitor is required across V_{PP} and ground to suppress spurious voltage transients.

DC Programming Characteristics

TA = 25 ± 5°C, V_{CC} = 6.5 ± 0.25V, V_{PP} = 13.0 ± 0.25V

Symbol	Parameter	Test Conditions	Limits		Units
			Min	Max	
I _{LI}	Input Load Current	V _{IN} = V _{IL} , V _{IH}		±10	μA
V _{IL}	Input Low Level		-0.6	0.8	V
V _{IH}	Input High Level		2.0	V _{CC} + 0.5	V
V _{OL}	Output Low Voltage	I _{OL} = 2.1 mA		0.4	V
V _{OH}	Output High Voltage	I _{OH} = -400 μA	2.4		V
I _{CC2}	V _{CC} Supply Current (Program and Verify)			50	mA
I _{PP2}	V _{PP} Supply Current	CE = V _{IL}		30	mA
V _{ID}	A9 Product Identification Voltage		11.5	12.5	V



AC Programming Characteristics

TA = 25 ± 5°C, V_{CC} = 6.5 ± 0.25V, V_{PP} = 13.0 ± 0.25V

Symbol	Parameter	Test Conditions ⁽¹⁾	Limits		Units
			Min	Max	
t _{AS}	Address Setup Time	Input Rise and Fall Times (10% to 90%) 20ns Input Pulse Levels 0.45V to 2.4V Input Timing Reference Level 0.8V to 2.0V Output Timing Reference Level 0.8V to 2.0V	2		μs
t _{OES}	\overline{OE} Setup Time		2		μs
t _{DS}	Data Setup Time		2		μs
t _{AH}	Address Hold Time		0		μs
t _{DH}	Data Hold Time		2		μs
t _{DFP}	\overline{OE} High to Output Float Delay ⁽²⁾		0	130	ns
t _{VPS}	V _{PP} Setup Time		2		μs
t _{VCS}	V _{CC} Setup Time		2		μs
t _{PW}	\overline{CE} Program Pulse Width ⁽³⁾		47.5	52.5	μs
t _{OE}	Data Valid from \overline{OE}			150	ns
t _{PRT}	\overline{BYTE}/V_{PP} Pulse Rise Time During Programming	50		ns	

- Notes:
1. V_{CC} must be applied simultaneously or before V_{PP} and removed simultaneously or after V_{PP}
 2. This parameter is only sampled and is not 100% tested. Output Float is defined as the point where data is no longer driven — see timing diagram.
 3. Program Pulse width tolerance is 50 μsec ± 5%.

Atmel's 27C400 Integrated Product Identification Code

Codes	Pins									Hex Data
	A0	O15	O14	O13	O12	O11	O10	O9	O8	
Manufacturer	0	0	0	0	1	1	1	1	0	1E1E
Device Type	1	1	1	1	1	0	1	0	0	F4F4

Rapid Programming Algorithm

A 50 μs $\overline{\text{CE}}$ pulse width is used to program. The address is set to the first location. V_{CC} is raised to 6.5V and $\overline{\text{BYTE}}/V_{\text{PP}}$ is raised to 13.0V. Each address is first programmed with one 50 μs $\overline{\text{CE}}$ pulse without verification. Then a verification/reprogramming loop is executed for each address. In the event a word fails to pass verification, up to 10 successive 50 μs pulses are applied with a verification after each

pulse. If the word fails to verify after 10 pulses have been applied, the part is considered failed. After the word verifies properly, the next address is selected until all have been checked. V_{PP} is then lowered to 5.0V and V_{CC} to 5.0V. All words are read again and compared with the original data to determine if the device passes or fails.

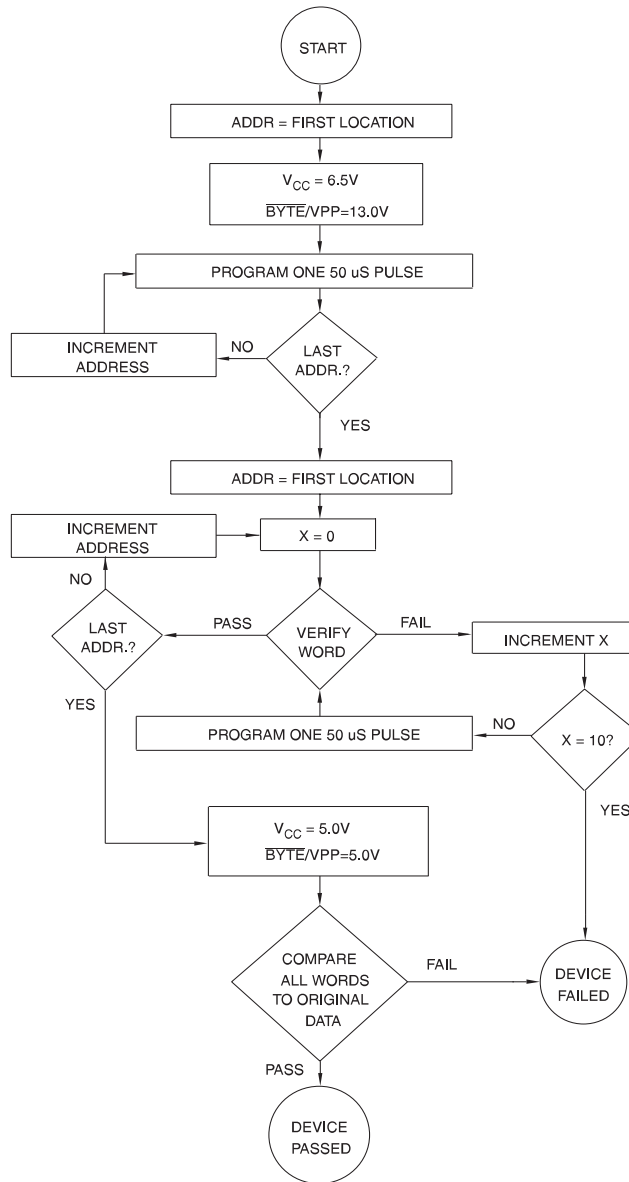



Ordering Information

t _{ACC} (ns)	I _{CC} (mA)		Ordering Code	Package	Operation Range
	Active	Standby			
70	40	0.1	AT27C400-70PC AT27C400-70RC AT27C400-70TC	40P6 40R 48T	Commercial (0°C to 70°C)
	40	0.1	AT27C400-70PI AT27C400-70RI AT27C400-70TI	40P6 40R 48T	Industrial (-40°C to 85°C)
90	40	0.1	AT27C400-90PC AT27C400-90RC AT27C400-90TC	40P6 40R 48T	Commercial (0°C to 70°C)
	40	0.1	AT27C400-90PI AT27C400-90RI AT27C400-90TI	40P6 40R 48T	Industrial (-40°C to 85°C)
120	40	0.1	AT27C400-12PC AT27C400-12RC AT27C400-12TC	40P6 40R 48T	Commercial (0°C to 70°C)
	40	0.1	AT27C400-12PI AT27C400-12RI AT27C400-12TI	40P6 40R 48T	Industrial (-40°C to 85°C)
150	40	0.1	AT27C400-15PC AT27C400-15RC AT27C400-15TC	40P6 40R 48T	Commercial (0°C to 70°C)
	40	0.1	AT27C400-15PI AT27C400-15RI AT27C400-15TI	40P6 40R 48T	Industrial (-40°C to 85°C)

 = Advance Information

Package Type	
40P6	40-Lead, 0.600" Wide, Plastic Dual Inline Package (PDIP)
40R	40-Lead, 0.450" Wide, Plastic Gull Wing Small Outline Package (SOIC/SOP)
48T	48-Lead, Plastic Thin Small Outline Package (TSOP) 12 x 20 mm