



## Pin Description

Pin	Symbol	Function
1	GND	IC ground
2	V <sub>S</sub>	Supply voltage V <sub>S</sub>
3	REL	Relay driver
4	OSC	C <sub>1</sub> Oscillator
5	OSC	R <sub>1</sub> Oscillator
6	V <sub>S</sub>	Supply voltage V <sub>S</sub>
7	LD	Lamp failure detection
8	SI	Start input (49a)

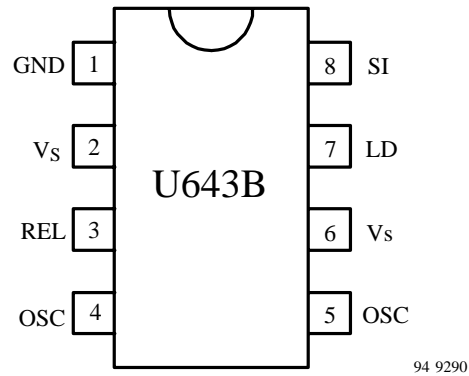

Figure 2. Pinning

## Functional Description

### Pin 1, GND

The integrated circuit is protected against damage via resistor R<sub>4</sub> to ground (–31) in the case of battery reversal. An integrated protection circuit together with external resistances R<sub>2</sub> and R<sub>4</sub> limits the current pulses in the IC.

### Pin 2, Supply voltage, V<sub>S</sub> - Power

The arrangement of the supply connections to Pin 2 must be so as to ensure that, on the connection printed circuit board (PCB), the resistance of V<sub>S</sub> to Pin 6 is lower than that to Pin 2.

### Pin 3, Relay control output (driver)

The relay control output is a high-side driver with a low saturation voltage and capable to drive a typical automotive relay with a minimum coil resistance of 60 Ω.

### Pin 4 and 5 Oscillator

Flashing frequency, f<sub>1</sub>, is determined by the R<sub>1</sub>C<sub>1</sub> components as follows (see figure 1):

$$f_1 \approx \frac{1}{R_1 \times C_1 \times 1.5} \text{ Hz}$$

where  $C_1 \leq 47 \mu\text{F}$   
 $R_1 = 6.8 \text{ k}\Omega \text{ to } 510 \text{ k}\Omega$

In the case of a lamp outage (see Pin 7) the oscillator frequency is switched to the lamp outage frequency f<sub>2</sub> with f<sub>2</sub> ≈ 2.2 × f<sub>1</sub>.

Duty cycle in normal flashing mode: 50%

Duty cycle in lamp outage mode: 40% (bright phase)

### Pin 6, Supply voltage, Sense

For accurate monitoring via the shunt resistor, a mini-

mized layer resistance from point V<sub>S</sub> / shunt to Pin 6 is recommended.

### Pin 7, Lamp outage detection

The lamp current is monitored via an external shunt resistor R<sub>3</sub> and an internal comparator K1 with its reference voltage of typ. 81 mV (V<sub>S</sub> = 12 V). The outage of one lamp out of two lamps is detected according to the following calculation:

Nominal current of 1 lamp: 21 W / (V<sub>S</sub> = 12 V):

$$I_{\text{lamp}} = 1.75 \text{ A}$$

Nominal current of 2 lamps: 2 x 21 W / (V<sub>S</sub> = 12 V):

$$I_{\text{lamp}} = 3.5 \text{ A.}$$

The detection threshold is recommended to be set in the middle of the current range: I<sub>outage</sub> ≈ 2.7 A

Thus the shunt resistor is calculated as:

$$R_3 = V_T (K1) / I_{\text{outage}}$$

$$R_3 = 81 \text{ mV} / 2.7 \text{ A} = 30 \text{ m}\Omega.$$

Comparator K1's reference voltage is matched to the characteristics of filament lamps (see "control signal threshold" in the data part).

The combination of shunt resistor and resistance of wire harness prevents Pin 7 from a too high voltage in the case of shorted lamps.

### Pin 8, Start input

Start condition for flashing: the voltage at Pin 8 has to be below K3 threshold (flasher switch closed).

Humidity and dirt may decrease the resistance between 49 a and GND. If this leakage resistance is > 5 kΩ the IC is still kept in its off-condition. In this case the voltage at Pin 8 is between the thresholds of comparators K2 and K3.

During the bright phase the voltage at Pin 8 is above the K2 threshold, during the dark phase it is below the K3 threshold. For proper start conditions a minimum lamp wattage of 1 W is required.

## Absolute Maximum Ratings

Reference point Pin 1

Parameters	Symbol	Value	Unit
Supply voltage Pin 2 and 6	$V_S$	16.5	V
Surge forward current			
$t_p = 0.1$ ms Pin 2 and 6	$I_{FSM}$	1.5	A
$t_p = 300$ ms Pin 2 and 6	$I_{FSM}$	1.0	A
$t_p = 300$ ms Pin 8	$I_{FSM}$	50	mA
Output current Pin 3	$I_O$	0.3	A
Power dissipation			
$T_{amb} = 95^\circ\text{C}$ DIP 8	$P_{tot}$	420	mW
SO 8	$P_{tot}$	340	mW
$T_{amb} = 60^\circ\text{C}$ DIP 8	$P_{tot}$	690	mW
SO 8	$P_{tot}$	560	mW
Junction temperature	$T_J$	150	$^\circ\text{C}$
Ambient temperature range	$T_{amb}$	-40 ... + 95	$^\circ\text{C}$
Storage temperature range	$T_{stg}$	-55 ... + 150	$^\circ\text{C}$

## Thermal Resistance

Parameters	Symbol	Value	Unit
Junction ambient DIP8	$R_{thJA}$	110	K/W
SO8	$R_{thJA}$	160	K/W

## Electrical Characteristics

Typical values under normal operation in application circuit (see figure 1),  $V_S$  (+49, Pin 2 and 6) = 12 V.  
Reference point ground (-31),  $T_{amb} = 25^\circ\text{C}$ , unless otherwise specified

Parameters	Test Conditions / Pins	Symbol	Min.	Typ.	Max.	Unit
Supply voltage range	Pin 2 and 6	$V_S$ (+49)		9 to 15		V
Supply current:	Pin 2 and 6					
Dark phase		$I_S$		4.5	8	mA
Bright phase		$I_S$		7.0	11	mA
Relay output:	Pin 3					
saturation voltage	$I_O = 150$ mA, $V_S = 9$ V with resistance = 60 $\Omega$	$V_O$			1.0	V
reverse current		$I_O$			0.1	mA
Start delay	First bright phase	$t_{on}$			10	ms
Frequency tolerance		$\delta f_1$	-5		+5	%
Bright period	Basic frequency $f_1$	$\Delta f_1$	47		53	%
	Control frequency $f_2$	$\Delta f_2$	37		45	%
Frequency increase	Lamp outage	$f_2$	2.15 $f_1$		2.3 $f_1$	Hz
Control signal threshold	$V_S = 15$ V Pin 7	$V_{R3}$	85	91	97	mV
	$V_S = 9$ V Pin 7	$V_{R3}$	66	71	76	mV
	$V_S = 12$ V Pin 7	$V_{R3}$	76	81	87	mV
Leakage resistance	49a to GND	$R_P$		4	5	k $\Omega$
Lamp load		$P_L$	1			W

## Package Information

### Package DIP8

Dimensions in mm

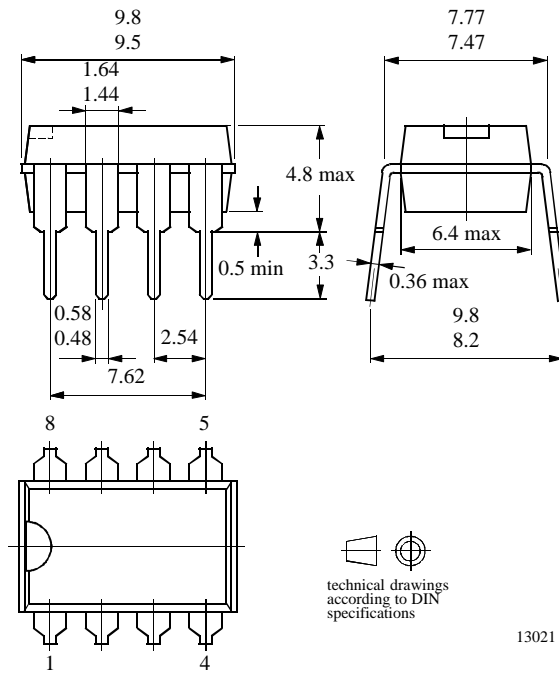

### Package SO8

Dimensions in mm

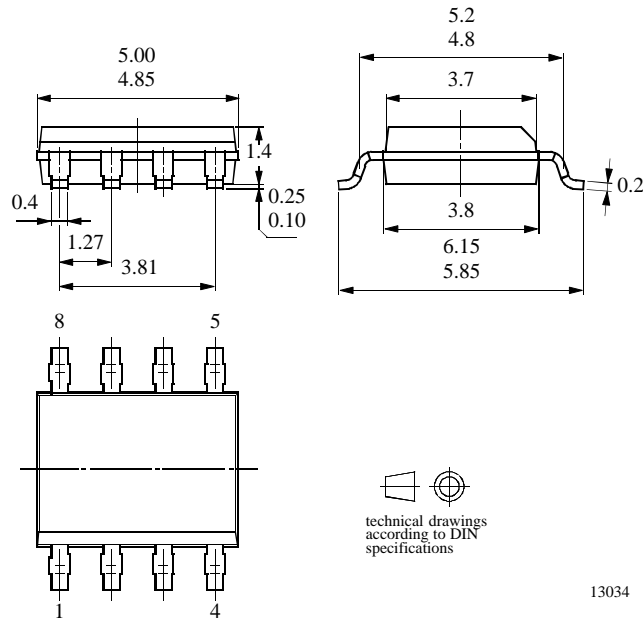

## Ozone Depleting Substances Policy Statement

It is the policy of **Atmel Germany GmbH** to

1. Meet all present and future national and international statutory requirements.
2. Regularly and continuously improve the performance of our products, processes, distribution and operating systems with respect to their impact on the health and safety of our employees and the public, as well as their impact on the environment.

It is particular concern to control or eliminate releases of those substances into the atmosphere which are known as ozone depleting substances (ODSs).

The Montreal Protocol (1987) and its London Amendments (1990) intend to severely restrict the use of ODSs and forbid their use within the next ten years. Various national and international initiatives are pressing for an earlier ban on these substances.

**Atmel Germany GmbH** has been able to use its policy of continuous improvements to eliminate the use of ODSs listed in the following documents.

1. Annex A, B and list of transitional substances of the Montreal Protocol and the London Amendments respectively
2. Class I and II ozone depleting substances in the Clean Air Act Amendments of 1990 by the Environmental Protection Agency (EPA) in the USA
3. Council Decision 88/540/EEC and 91/690/EEC Annex A, B and C (transitional substances) respectively.

**Atmel Germany GmbH** can certify that our semiconductors are not manufactured with ozone depleting substances and do not contain such substances.

**We reserve the right to make changes to improve technical design and may do so without further notice.**

Parameters can vary in different applications. All operating parameters must be validated for each customer application by the customer. Should the buyer use Atmel Wireless & Microcontrollers products for any unintended or unauthorized application, the buyer shall indemnify Atmel Wireless & Microcontrollers against all claims, costs, damages, and expenses, arising out of, directly or indirectly, any claim of personal damage, injury or death associated with such unintended or unauthorized use.

**Data sheets can also be retrieved from the Internet: <http://www.atmel-wm.com>**

Atmel Germany GmbH, P.O.B. 3535, D-74025 Heilbronn, Germany  
Telephone: 49 (0)7131 67 2594, Fax number: 49 (0)7131 67 2423