



Austin Semiconductor, Inc.

SRAM AS5C4008

512K x 8 SRAM

SRAM MEMORY ARRAY

AVAILABLE AS MILITARY SPECIFICATION

- SMD 5962-95600
- SMD 5962-95613
- MIL STD-883

FEATURES

- High Speed: 17, 20, 25, 35 and 45ns
- High-performance, low power military grade device
- Single +5V $\pm 10\%$ power supply
- Easy memory expansion with CE\ and OE\ options
- All inputs and outputs are TTL-compatible
- Ease of upgradability from 1 Meg using the 32 pin evolutionary version.

OPTIONS

- Timing
 - 15ns access (contact factory)
 - 17ns access
 - 20ns access
 - 25ns access
 - 35ns access
 - 45ns access

MARKING

- Operating Temperature Range
 - Military: -55°C to +125°C
 - Industrial: -40°C to +85°C
- Packages

Ceramic Dip (600 mil)	CW	No. 112
Ceramic Flatpack	F	No. 304
Ceramic LCC	EC	No. 209
Ceramic SOJ	ECJ	No. 502
Ceramic LCC (contact factory)	ECA	No. 208
- Options
 - 2V data retention/ low power

NOTE: Not all combinations of operating temperature, speed, data retention and low power are necessarily available. Please contact factory for availability of specific part number combinations.

GENERAL DESCRIPTION

The AS5C4008 is a 4 megabit monolithic CMOS SRAM, organized as a 512K x 8.

The evolutionary 32 pin device allows for easy upgrades from the 1 meg SRAM.

For flexibility in high-speed memory applications, ASI offers chip enable (CE\) and output enable (OE\) capabilities. These enhancements can place the outputs in High-Z for additional flexibility in system design.

Writing to these devices is accomplished when write enable (WE\) and CE\ inputs are both LOW. Reading is accomplished when WE\ remains HIGH and CE\ and OE\ go LOW. This allows systems designers to meet low standby power requirements.

All devices operate from a single +5V power supply and all inputs are fully TTL-Compatible.

PIN ASSIGNMENT (Top View)

32-Pin DIP (CW), 32-Pin LCC (EC)
32-Pin SOJ (ECJ)

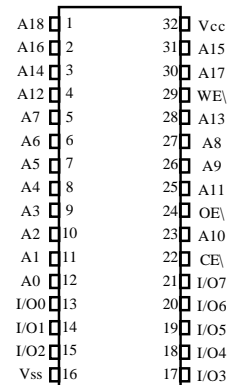

32-Pin Flat Pack (F)

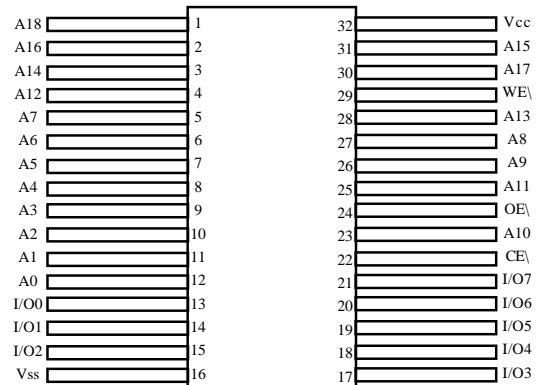

32-Pin LCC (ECA)

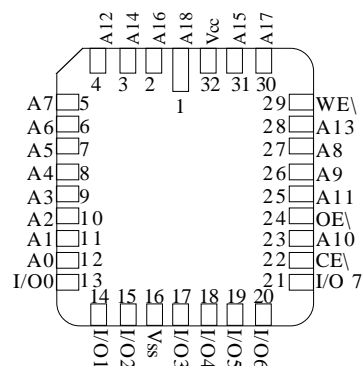

For more products and information
please visit our web site at
www.austinsemiconductor.com

FUNCTIONAL BLOCK DIAGRAM

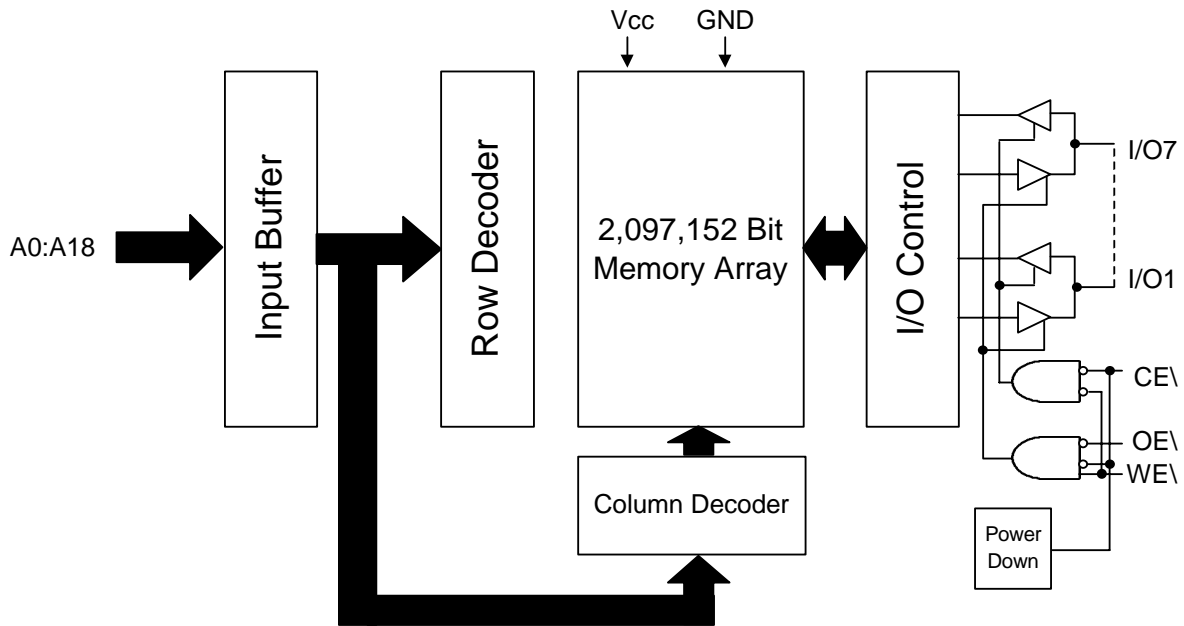

TRUTH TABLE

MODE	OE\<	CE\<	WE\<	DQ	POWER
STANDBY	X	H	X	High-Z	STANDBY
READ	L	L	H	Q	ACTIVE
NOT SELECTED	H	L	H	High-Z	ACTIVE
WRITE	X	L	L	D	ACTIVE



ABSOLUTE MAXIMUM RATINGS*

Voltage on Vcc Supply Relative to Vss.....-5V to +7.0V
 Storage Temperature-65°C to +150°C
 Short Circuit Output Current (per I/O).....20mA
 Voltage on any Pin Relative to Vss.....-5V to Vcc+1 V
 Maximum Junction Temperature**.....+150°C

*Stresses greater than those listed under "Absolute Maximum Ratings" may cause permanent damage to the device. This is a stress rating only and functional operation of the device at these or any other conditions above those indicated in the operation section of this specification is not implied. Exposure to absolute maximum rating conditions for extended periods may affect reliability.

** Junction temperature depends upon package type, cycle time, loading, ambient temperature and airflow.

ELECTRICAL CHARACTERISTICS AND RECOMMENDED DC OPERATING CONDITIONS
 (-55°C ≤ T_A ≤ 125°C or -40°C to +85°C; Vcc = 5V ±10%)

PARAMETER	CONDITION	SYMBOL	MIN	MAX	UNITS	NOTES
Input High (Logic 1) Voltage		V _{IH}	2.2	V _{CC} +0.5	V	1
Input Low (Logic 0) Voltage		V _{IL}	-0.5	0.8	V	1, 2
Input Leakage Current	0V ≤ V _{IN} ≤ V _{CC}	I _{LI}	-10	10	μA	
Output Leakage Current	Output(s) disabled 0V ≤ V _{OUT} ≤ V _{CC}	I _{LO}	-10	10	μA	
Output High Voltage	I _{OH} = -4.0 mA	V _{OH}	2.4	--	V	1
Output Low Voltage	I _{OL} = 8.0 mA	V _{OL}	---	0.4	V	1
Supply Voltage		V _{CC}	4.5	5.5	V	1

PARAMETER	CONDITIONS	SYM	MAX						UNITS	NOTES
			-15	-17	-20	-25	-35	-45		
Power Supply Current: Operating	CE\ ≤ V _{IL} ; V _{CC} = MAX f = MAX = 1/t _{RC} Outputs Open	I _{CCSP}	225	225	225	225	225	225	mA	3
	L Version Only	I _{CCLP}	180	180	180	180	180	180	mA	
Power Supply Current: Standby	CE\ ≥ V _{IH} ; V _{CC} = MAX f = 0, Outputs Open	I _{SBTSP}	60	60	60	60	60	60	mA	
	L Version Only	I _{SBTLP}	30	30	30	30	30	30	mA	
	CE\ ≤ V _{CC} -0.2V; V _{CC} = MAX V _{IN} ≤ V _{SS} +0.2V or V _{IN} ≥ V _{CC} -0.2V; f = 0	I _{SBCSP}	25	25	25	25	25	25	mA	
	L Version Only	I _{SBCLP}	10	10	10	10	10	10	mA	

CAPACITANCE

PARAMETER	CONDITIONS	SYMBOL	MAX	UNITS	NOTES
Input Capacitance	T _A = 25°C, f = 1MHz V _{IN} = 0	C _I	12	pF	4
Output Capacitance		C _O	14	pF	4



ELECTRICAL CHARACTERISTICS AND RECOMMENDED AC OPERATING CONDITIONS
($-55^{\circ}\text{C} \leq T_A \leq 125^{\circ}\text{C}$ or -40°C to $+85^{\circ}\text{C}$; $V_{CC} = 5\text{V} \pm 10\%$)

DESCRIPTION	SYM	-15		-17		-20		-25		-35		-45		UNITS	NOTES
		MIN	MAX	MIN	MAX	MIN	MAX	MIN	MAX	MIN	MAX	MIN	MAX		
READ CYCLE															
Read Cycle Time	t_{RC}	15		17		20		25		35		45		ns	
Address Access Time	t_{AA}		15		17		20		25		35		45	ns	
Chip Enable Access Time	t_{ACE}		15		17		20		25		35		45	ns	
Output Hold From Address Change	t_{OH}	2		2		2		2		2		2		ns	
Chip Enable to Output in Low-Z	t_{LZCE}	2		2		2		2		2		2		ns	4, 6, 7
Chip Disable to Output in High-Z	t_{HZCE}	0	7	0	8	0	8	0	10	0	15	0	20	ns	4, 6, 7
Output Enable Access Time	t_{AOE}		8		8		10		12		15		25	ns	
Output Enable to Output in Low-Z	t_{LZOE}	0		0		0		0		0		0		ns	4, 6, 7
Output Disable to Output in High-Z	t_{HZOE}	0	7	0	8	0	8	0	10	0	15	0	20	ns	4, 6, 7
WRITE CYCLE															
WRITE Cycle Time	t_{WC}	15		17		20		25		35		45		ns	
Chip Enable to End of Write	t_{CW}	15		16		17		20		30		35		ns	
Address Valid to End of Write	t_{AW}	15		16		17		20		30		35		ns	
Address Setup Time	t_{AS}	0		0		0		0		0		0		ns	
Address Hold From End of Write	t_{AH}	0		1		1		1		1		1		ns	
WRITE Pulse Width	t_{WP}	15		16		17		20		30		35		ns	
Data Setup Time	t_{DS}	7		9		10		12		20		25		ns	
Data Hold Time	t_{DH}	0		0		0		0		0		0		ns	
Write Disable to Output in Low-Z	t_{LZWE}	0		0		0		0		0		0		ns	4, 6, 7
Write Enable to Output in High-Z	t_{HZWE}	0	7	0	8	0	8	0	10	0	25	0	30	ns	4, 6, 7



AC TEST CONDITIONS

Input pulse levels	V _{ss} to 3.0V
Input rise and fall times	3ns
Input timing reference levels	1.5V
Output reference levels	1.5V
Output load	See Figures 1 and 2

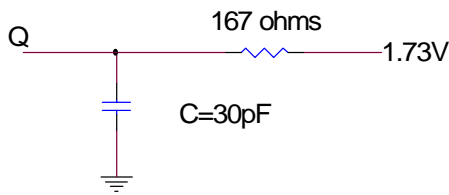

Fig. 1 Output Load Equivalent

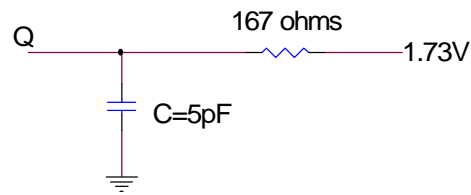

Fig. 2 Output Load Equivalent

NOTES

1. All voltages referenced to V_{ss} (GND).
2. -2V for pulse width < 20ns
3. I_{CC} is dependent on output loading and cycle rates.
4. This parameter is guaranteed but not tested.
5. Test conditions as specified with the output loading as shown in Fig. 1 unless otherwise noted.
6. 'LZCE, 'LZWE, 'LZOE, 'HZCE, 'HZOE and 'HZWE are specified with CL = 5pF as in Fig. 2. Transition is measured ±200mV from steady state voltage.
7. At any given temperature and voltage condition, 'HZCE is less than 'LZCE, and 'HZWE is less than 'LZWE.
8. WE\ is HIGH for READ cycle.
9. Device is continuously selected. Chip enables and output enables are held in their active state.
10. Address valid prior to, or coincident with, latest occurring chip enable.
11. 'RC = Read Cycle Time.
12. Chip enable and write enable can initiate and terminate a WRITE cycle.
13. Output enable (OE\) is inactive (HIGH).
14. Output enable (OE\) is active (LOW).
15. ASI does not warrant functionality nor reliability of any product in which the junction temperature exceeds 150°C. Care should be taken to limit power to acceptable levels.

DATA RETENTION ELECTRICAL CHARACTERISTICS (L Version Only)

DESCRIPTION	CONDITIONS	SYMBOL	MIN	MAX	UNITS	NOTES
V _{CC} for Retention Data	CE\ > (V _{CC} - 0.2V) VIN > (V _{CC} - 0.2V) or < 0.2V	V _{DR}	2		V	
Data Retention Current (L Version Only)	V _{CC} = 2V	I _{CCDR}		4.5	mA	
Chip Deselect to Data Retention Time		t _{CDR}	0		ns	4
Operation Recovery Time		t _R	10		ms	4, 11



LOW V_{CC} DATA RETENTION WAVEFORM

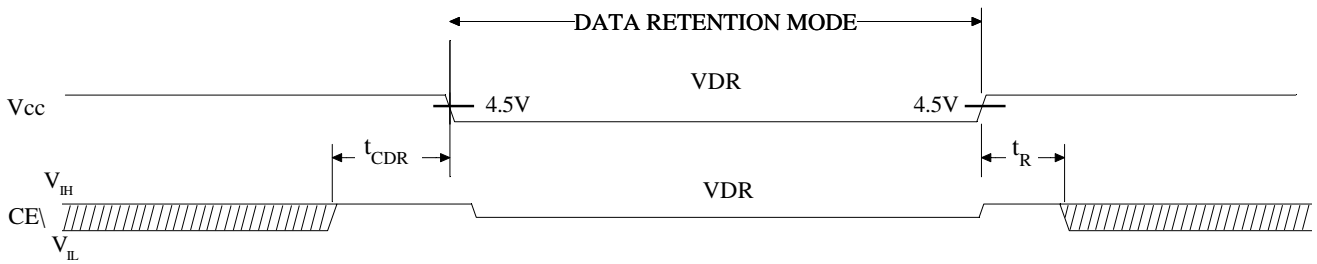

READ CYCLE NO. 1 ^{8,9}
(Write Enabled Controlled)

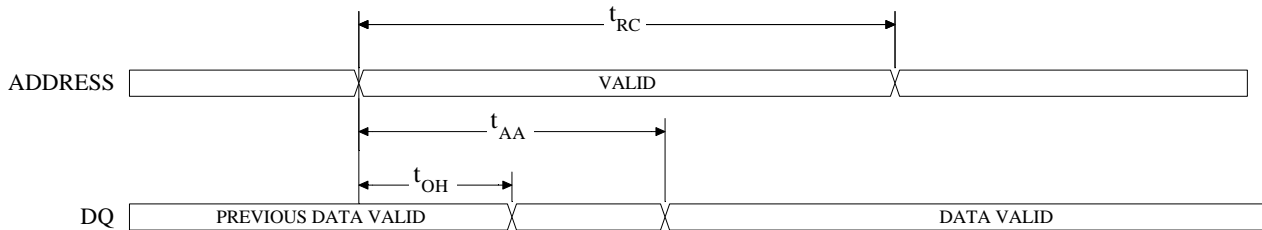

READ CYCLE NO. 2 ^{7,8,10}
(Write Enabled Controlled)

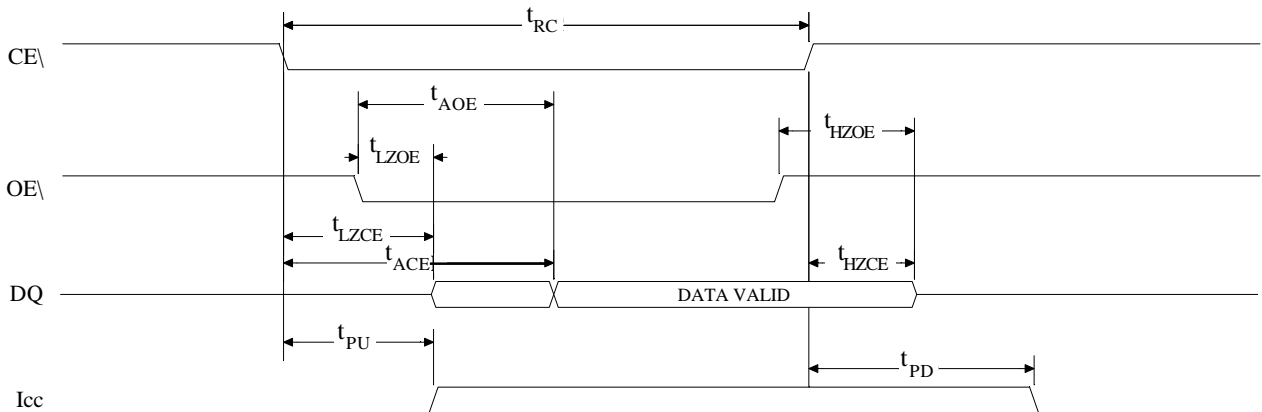



WRITE CYCLE NO. 1 ¹²
(Chip Enabled Controlled)

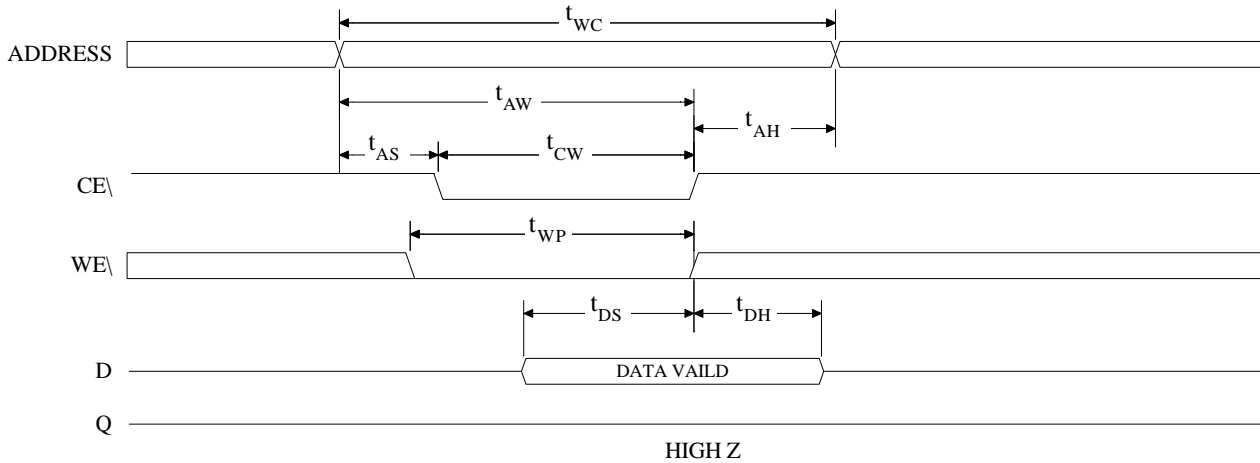

WRITE CYCLE NO. 2 ^{12,13}
(Write Enabled Controlled)

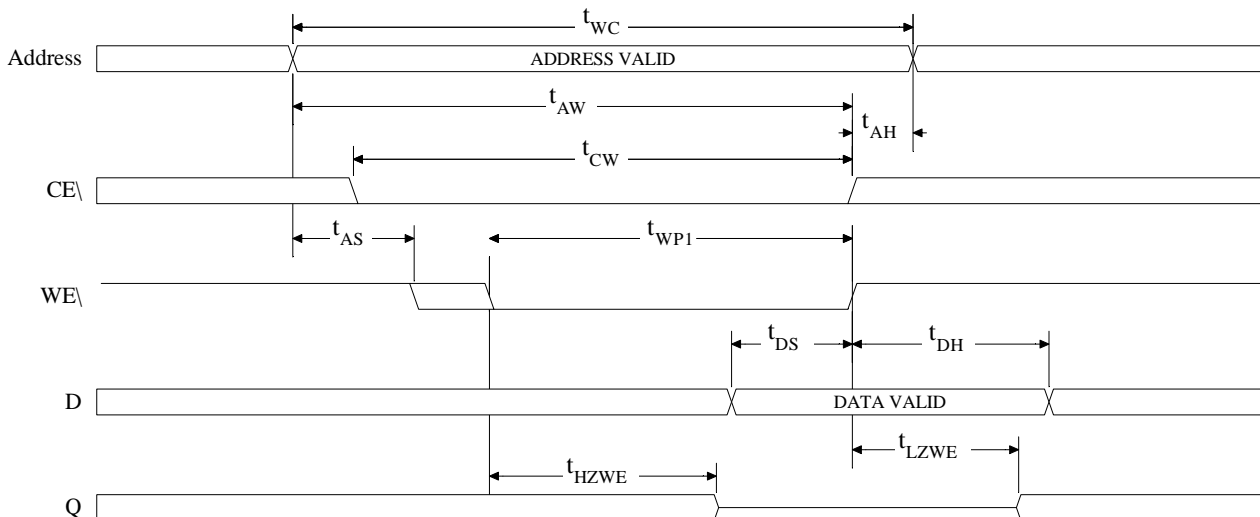



WRITE CYCLE NO. 37, 12, 14
(Write Enable Controlled)

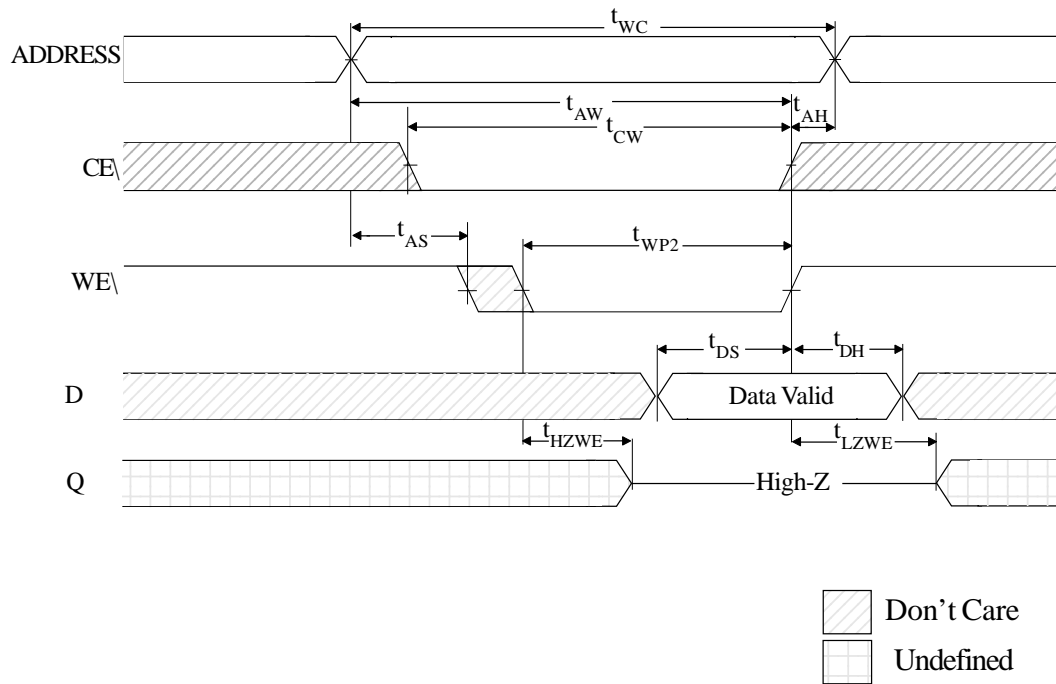



MECHANICAL DEFINITION*

ASI Case #112 (Package Designator CW)
SMD 5962-95600, Case Outline X

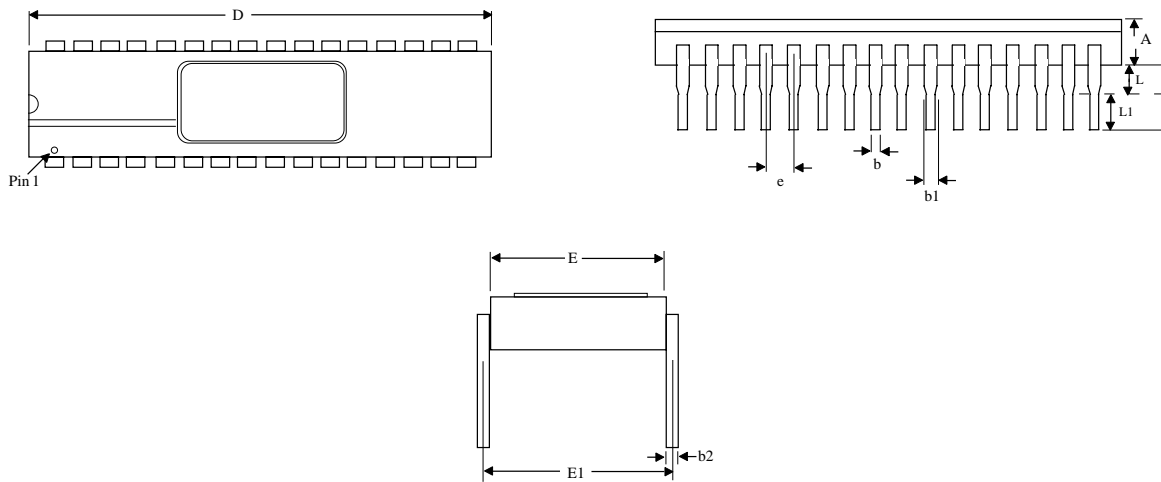

SYMBOL	SMD Specifications	
	MIN	MAX
A	---	0.225
b	0.014	0.026
b1	0.045	0.065
b2	0.008	0.018
D	---	1.680
E	0.510	0.620
e	0.100 BSC	
E1	0.600 BSC	
L1	0.125	0.200
L	0.015	0.070

NOTE: *These dimensions are per the SMD. ASI's package dimensional limits may differ, but they will be within the SMD limits.*

*All measurements are in inches.



MECHANICAL DEFINITION*

ASI Case #304 (Package Designator F)
SMD 5962-95600, Case Outline 9

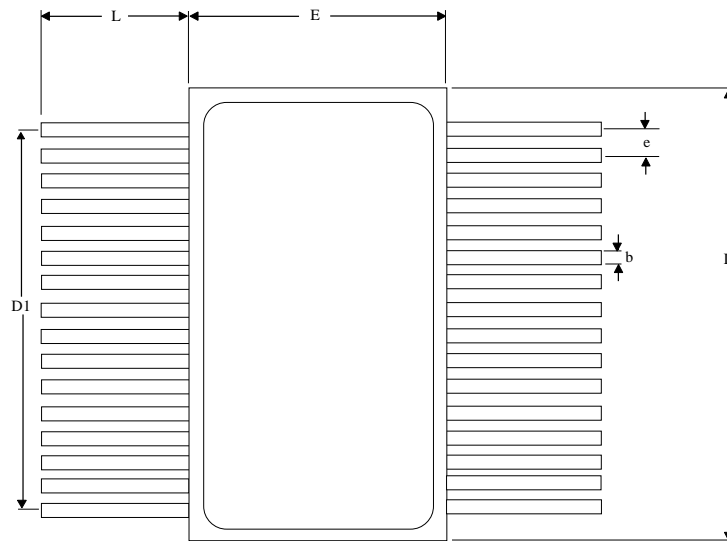

Top View

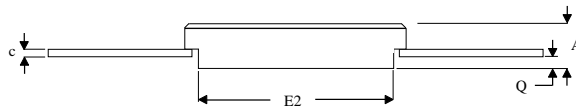

SYMBOL	SMD SPECIFICATIONS	
	MIN	MAX
A	0.096	0.114
b	0.008	0.019
c	0.003	0.008
D	0.816	0.838
D1	0.742	0.758
E	0.419	0.460
E2	0.345	0.427
e	0.050 BSC	
L	0.290	0.310
Q	0.024	0.038

NOTE: These dimensions are per the SMD. ASI's package dimensional limits may differ, but they will be within the SMD limits.

*All measurements are in inches.



MECHANICAL DEFINITION*

**ASI Case #209 (Package Designator EC)
SMD 5962-95600, Case Outline Z**

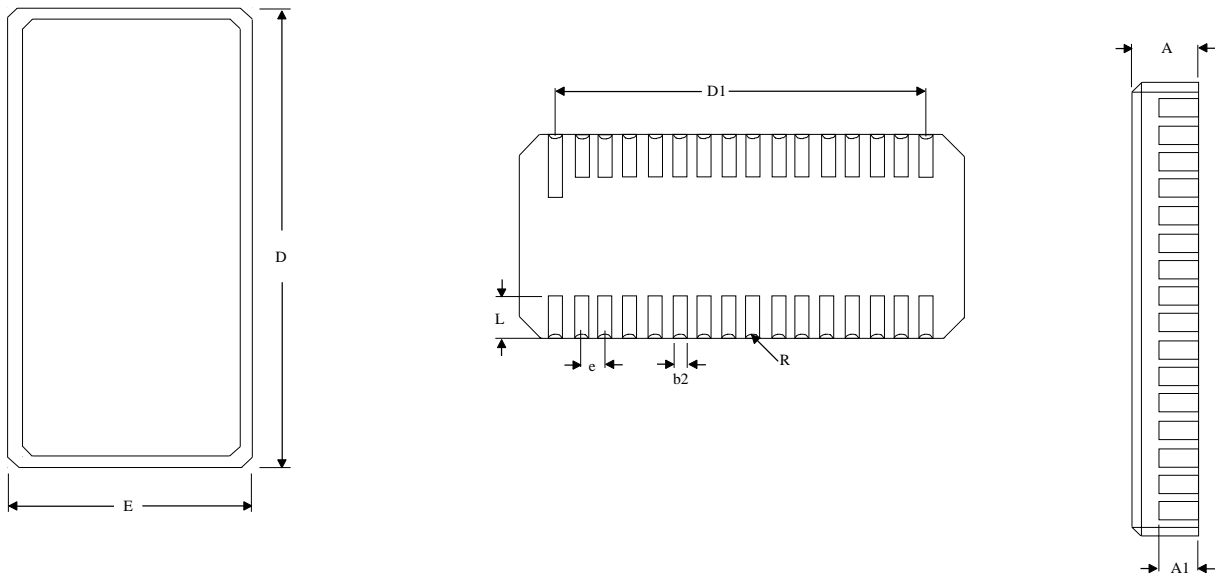

SYMBOL	SMD SPECIFICATIONS	
	MIN	MAX
A	0.080	0.100
A1	0.006	0.054
b2	0.022	0.028
D	0.815	0.835
D1	0.740	0.760
E	0.440	0.460
e	0.050 BSC	
L	0.100 REF	
R	0.009 REF	

NOTE: These dimensions are per the SMD. ASI's package dimensional limits may differ, but they will be within the SMD limits.

*All measurements are in inches.



MECHANICAL DEFINITION*

ASI Case #502 (Package Designator ECJ)

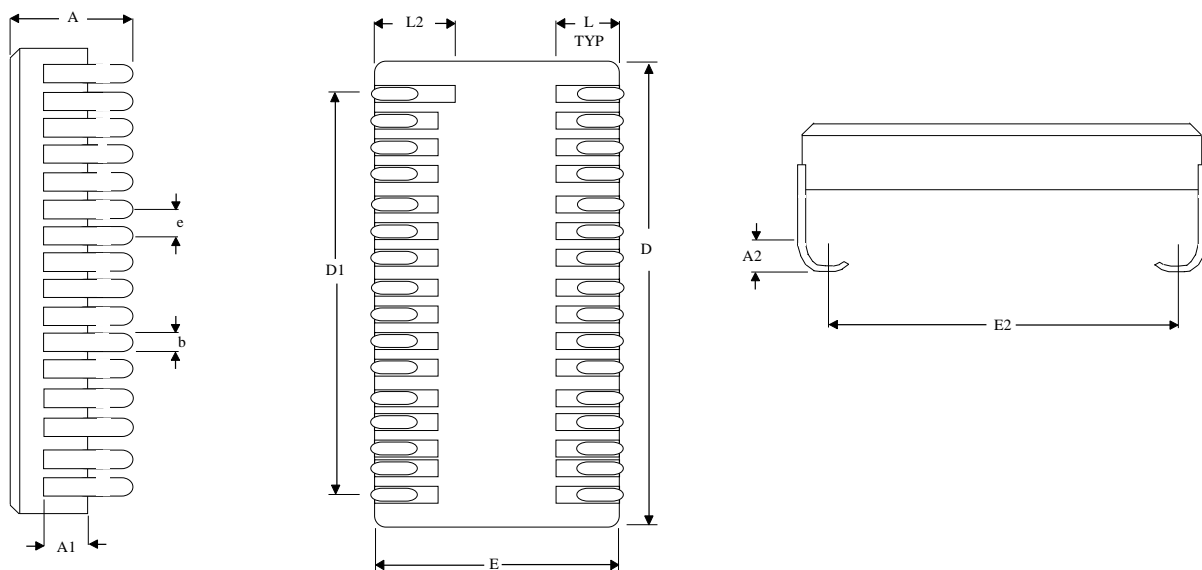

SYMBOL	ASI SPECIFICATIONS	
	MIN	MAX
A	0.115	0.160
A1	0.054	0.075
A2	0.025	0.063
b	0.012	0.028
D	0.815	0.835
D1	0.740	0.760
E	0.418	0.460
E2	0.371	0.440
e	0.050 BSC	
L	0.050	0.070
L2	0.115	0.135

NOTE: This package meets SMD 5962-95600, Case Outline U dimensions in every aspect, except dimension E2.

**All measurements are in inches.*



MECHANICAL DEFINITION*

ASI Case #208 (Package Designator ECA)

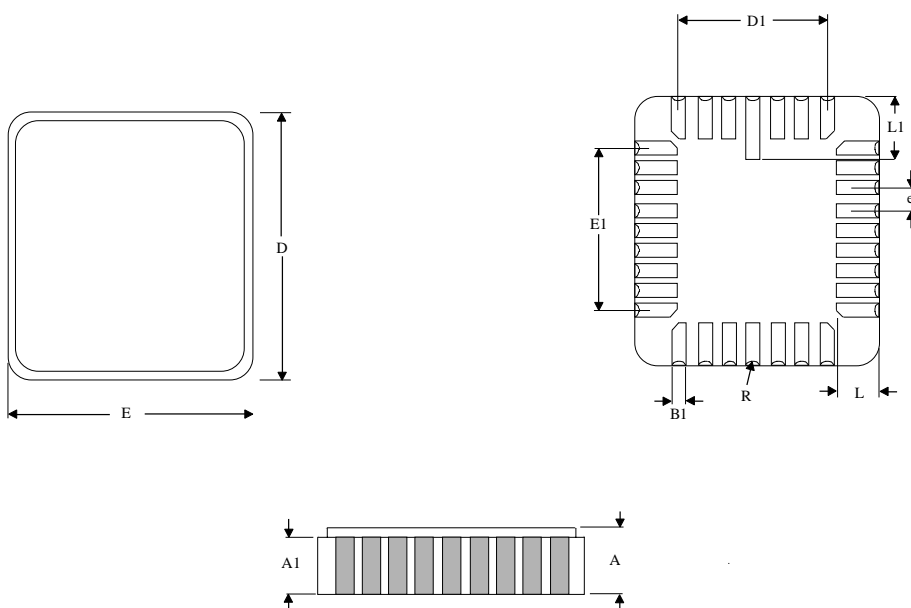

SYMBOL	SMD SPECIFICATIONS	
	MIN	MAX
A	0.060	0.080
A1	0.040	0.050
B1	0.022	0.028
D	0.540	0.560
D1	0.390	0.410
E	0.442	0.458
E1	0.290	0.310
e	0.045	0.055
L	0.045	0.055
L1	0.075	0.095
R	0.004	0.014

*All measurements are in inches.



ORDERING INFORMATION

EXAMPLE: AS5C4008CW-25L/883C

Device Number	Package Type	Speed ns	Options**	Process
AS5C4008	CW	-15	L	/*
AS5C4008	CW	-17	L	/*
AS5C4008	CW	-20	L	/*
AS5C4008	CW	-25	L	/*
AS5C4008	CW	-35	L	/*
AS5C4008	CW	-45	L	/*

EXAMPLE: AS5C4008ECA-45/883C

Device Number	Package Type	Speed ns	Options**	Process
AS5C4008	ECA	-15	L	/*
AS5C4008	ECA	-17	L	/*
AS5C4008	ECA	-20	L	/*
AS5C4008	ECA	-25	L	/*
AS5C4008	ECA	-35	L	/*
AS5C4008	ECA	-45	L	/*

EXAMPLE: AS5C4008EC-20/883C

Device Number	Package Type	Speed ns	Options**	Process
AS5C4008	EC	-15	L	/*
AS5C4008	ECJ	-15	L	/*
AS5C4008	EC	-17	L	/*
AS5C4008	ECJ	-17	L	/*
AS5C4008	EC	-20	L	/*
AS5C4008	ECJ	-20	L	/*
AS5C4008	EC	-25	L	/*
AS5C4008	ECJ	-25	L	/*
AS5C4008	EC	-35	L	/*
AS5C4008	ECJ	-35	L	/*
AS5C4008	EC	-45	L	/*
AS5C4008	ECJ	-45	L	/*

EXAMPLE: AS5C4008F-45L/883C

Device Number	Package Type	Speed ns	Options**	Process
AS5C4008	F	-15	L	/*
AS5C4008	F	-17	L	/*
AS5C4008	F	-20	L	/*
AS5C4008	F	-25	L	/*
AS5C4008	F	-35	L	/*
AS5C4008	F	-45	L	/*

***AVAILABLE PROCESSES**

IT = Industrial Temperature Range
 XT = Extended Temperature Range
 883C = Full Military Processing

-40°C to +85°C
 -55°C to +125°C
 -55°C to +125°C

****DEFINITION OF OPTIONS**

2V Data Retention/Low Power

L



**ASI TO DSCC PART NUMBER
CROSS REFERENCE
FOR 5962-95600**

Package Designator CW

<u>ASI Part #</u>	<u>SMD Part</u>
AS5C4008CW-15/883C	5962-9560014MXA
AS5C4008CW-20/883C	5962-9560004MXA
AS5C4008CW-25/883C	5962-9560003MXA
AS5C4008CW-35/883C	5962-9560002MXA
AS5C4008CW-45/883C	5962-9560001MXA
AS5C4008CW-15L/883C	5962-9560013MXA
AS5C4008CW-20L/883C	5962-9560008MXA
AS5C4008CW-25L/883C	5962-9560007MXA
AS5C4008CW-35L/883C	5962-9560006MXA
AS5C4008CW-45L/883C	5962-9560005MXA

Package Designator F

<u>ASI Part #</u>	<u>SMD Part#</u>
AS5C4008F-15/883C	5962-9560014M9A
AS5C4008F-20/883C	5962-9560004M9A
AS5C4008F-25/883C	5962-9560003M9A
AS5C4008F-35/883C	5962-9560002M9A
AS5C4008F-45/883C	5962-9560001M9A
AS5C4008F-15L/883C	5962-9560013M9A
AS5C4008F-20L/883C	5962-9560008M9A
AS5C4008F-25L/883C	5962-9560007M9A
AS5C4008F-35L/883C	5962-9560006M9A
AS5C4008F-45L/883C	5962-9560005M9A

Package Designator EC

<u>ASI Part #</u>	<u>SMD Part#</u>
AS5C4008EC-15/883C	5962-9560014MZA
AS5C4008EC-20/883C	5962-9560004MZA
AS5C4008EC-25/883C	5962-9560003MZA
AS5C4008EC-35/883C	5962-9560002MZA
AS5C4008EC-45/883C	5962-9560001MZA
AS5C4008EC-15L/883C	5962-9560013MZA
AS5C4008EC-20L/883C	5962-9560008MZA
AS5C4008EC-25L/883C	5962-9560007MZA
AS5C4008EC-35L/883C	5962-9560006MZA
AS5C4008EC-45L/883C	5962-9560005MZA

Package Designator ECJ

<u>ASI Part #</u>	<u>SMD Part#</u>
AS5C4008EC-15/883C	5962-9560014MUA
AS5C4008ECJ-20/883C	5962-9560004MUA
AS5C4008ECJ-25/883C	5962-9560003MUA
AS5C4008ECJ-35/883C	5962-9560002MUA
AS5C4008ECJ-45/883C	5962-9560001MUA
AS5C4008EC-15L/883C	5962-9560013MUA
AS5C4008ECJ-20L/883C	5962-9560008MUA
AS5C4008ECJ-25L/883C	5962-9560007MUA
AS5C4008ECJ-35L/883C	5962-9560006MUA
AS5C4008ECJ-45L/883C	5962-9560005MUA

* ASI part number is for reference only. Orders received referencing the SMD part number will be processed per the SMD.



**ASI TO DSCC PART NUMBER
CROSS REFERENCE
FOR 5962-95613**

Package Designator CW

ASI Part #	SMD Part
AS5C4008CW-55/H	5962-9561305HYA
AS5C4008CW-55L/H	5962-9561319HYA
AS5C4008CW-45/H	5962-9561306HYA
AS5C4008CW-45L/H	5962-9561320HYA
AS5C4008CW-45/H	5962-9561311HYA
AS5C4008CW-45L/H	5962-9561325HYA
AS5C4008CW-35/H	5962-9561307HYA
AS5C4008CW-35L/H	5962-9561321HYA
AS5C4008CW-35/H	5962-9561312HYA
AS5C4008CW-35L/H	5962-9561326HYA
AS5C4008CW-25/H	5962-9561308HYA
AS5C4008CW-25L/H	5962-9561322HYA
AS5C4008CW-25/H	5962-9561313HYA
AS5C4008CW-25L/H	5962-9561327HYA
AS5C4008CW-20/H	5962-9561309HYA
AS5C4008CW-20L/H	5962-9561323HYA
AS5C4008CW-17/H	5962-9561310HYA
AS5C4008CW-17L/H	5962-9561324HYA
AS5C4008CW-55/H	5962-9561305HYC
AS5C4008CW-55L/H	5962-9561319HYC
AS5C4008CW-45/H	5962-9561306HYC
AS5C4008CW-45L/H	5962-9561320HYC
AS5C4008CW-45/H	5962-9561311HYC
AS5C4008CW-45L/H	5962-9561325HYC
AS5C4008CW-35/H	5962-9561307HYC
AS5C4008CW-35L/H	5962-9561321HYC
AS5C4008CW-35/H	5962-9561312HYC
AS5C4008CW-35L/H	5962-9561326HYC
AS5C4008CW-25/H	5962-9561308HYC
AS5C4008CW-25L/H	5962-9561322HYC
AS5C4008CW-25/H	5962-9561313HYC
AS5C4008CW-25L/H	5962-9561327HYC
AS5C4008CW-20/H	5962-9561309HYC
AS5C4008CW-20L/H	5962-9561323HYC
AS5C4008CW-17/H	5962-9561310HYC
AS5C4008CW-17L/H	5962-9561324HYC

Package Designator F

ASI Part #	SMD Part#
AS5C4008F-55/H	5962-9561305H9A
AS5C4008F-55L/H	5962-9561319H9A
AS5C4008F-45/H	5962-9561306H9A
AS5C4008F-45L/H	5962-9561320H9A
AS5C4008F-45/H	5962-9561311H9A
AS5C4008F-45L/H	5962-9561325H9A
AS5C4008F-35/H	5962-9561307H9A
AS5C4008F-35L/H	5962-9561321H9A
AS5C4008F-35/H	5962-9561312H9A
AS5C4008F-35L/H	5962-9561326H9A
AS5C4008F-25/H	5962-9561308H9A
AS5C4008F-25L/H	5962-9561322H9A
AS5C4008F-25/H	5962-9561313H9A
AS5C4008F-25L/H	5962-9561327H9A
AS5C4008F-20/H	5962-9561309H9A
AS5C4008F-20L/H	5962-9561323H9A
AS5C4008F-17/H	5962-9561310H9A
AS5C4008F-17L/H	5962-9561324H9A
AS5C4008F-55/H	5962-9561305H9C
AS5C4008F-55L/H	5962-9561319H9C
AS5C4008F-45/H	5962-9561306H9C
AS5C4008F-45L/H	5962-9561320H9C
AS5C4008F-45/H	5962-9561311H9C
AS5C4008F-45L/H	5962-9561325H9C
AS5C4008F-35/H	5962-9561307H9C
AS5C4008F-35L/H	5962-9561321H9C
AS5C4008F-35/H	5962-9561312H9C
AS5C4008F-35L/H	5962-9561326H9C
AS5C4008F-25/H	5962-9561308H9C
AS5C4008F-25L/H	5962-9561322H9C
AS5C4008F-25/H	5962-9561313H9C
AS5C4008F-25L/H	5962-9561327H9C
AS5C4008F-20/H	5962-9561309H9C
AS5C4008F-20L/H	5962-9561323H9C
AS5C4008F-17/H	5962-9561310H9C
AS5C4008F-17L/H	5962-9561324H9C

* ASI part number is for reference only. Orders received referencing the SMD part number will be processed per the SMD.

Continued on next page



**ASI TO DSCC PART NUMBER
CROSS REFERENCE
FOR 5962-95613**

Package Designator EC		Package Designator ECJ	
ASI Part #	SMD Part	ASI Part #	SMD Part#
AS5C4008EC-55/H	5962-9561305HMA	AS5C4008ECJ-55/H	5962-9561305HTA
AS5C4008EC-55L/H	5962-9561319HMA	AS5C4008ECJ-55L/H	5962-9561319HTA
AS5C4008EC-45/H	5962-9561306HMA	AS5C4008ECJ-45/H	5962-9561306HTA
AS5C4008EC-45L/H	5962-9561320HMA	AS5C4008ECJ-45L/H	5962-9561320HTA
AS5C4008EC-45/H	5962-9561311HMA	AS5C4008ECJ-45/H	5962-9561311HTA
AS5C4008EC-45L/H	5962-9561325HMA	AS5C4008ECJ-45L/H	5962-9561325HTA
AS5C4008EC-35/H	5962-9561307HMA	AS5C4008ECJ-35/H	5962-9561307HTA
AS5C4008EC-35L/H	5962-9561321HMA	AS5C4008ECJ-35L/H	5962-9561321HTA
AS5C4008EC-35/H	5962-9561312HMA	AS5C4008ECJ-35/H	5962-9561312HTA
AS5C4008EC-35L/H	5962-9561326HMA	AS5C4008ECJ-35L/H	5962-9561326HTA
AS5C4008EC-25/H	5962-9561308HMA	AS5C4008ECJ-25/H	5962-9561308HTA
AS5C4008EC-25L/H	5962-9561322HMA	AS5C4008ECJ-25L/H	5962-9561322HTA
AS5C4008EC-25/H	5962-9561313HMA	AS5C4008ECJ-25/H	5962-9561313HTA
AS5C4008EC-25L/H	5962-9561327HMA	AS5C4008ECJ-25L/H	5962-9561327HTA
AS5C4008EC-20/H	5962-9561309HMA	AS5C4008ECJ-20/H	5962-9561309HTA
AS5C4008EC-20L/H	5962-9561323HMA	AS5C4008ECJ-20L/H	5962-9561323HTA
AS5C4008EC-17/H	5962-9561310HMA	AS5C4008ECJ-17/H	5962-9561310HTA
AS5C4008EC-17L/H	5962-9561324HMA	AS5C4008ECJ-17L/H	5962-9561324HTA
AS5C4008EC-55/H	5962-9561305HMC	AS5C4008ECJ-55/H	5962-9561305HTC
AS5C4008EC-55L/H	5962-9561319HMC	AS5C4008ECJ-55L/H	5962-9561319HTC
AS5C4008EC-45/H	5962-9561306HMC	AS5C4008ECJ-45/H	5962-9561306HTC
AS5C4008EC-45L/H	5962-9561320HMC	AS5C4008ECJ-45L/H	5962-9561320HTC
AS5C4008EC-45/H	5962-9561311HMC	AS5C4008ECJ-45/H	5962-9561311HTC
AS5C4008EC-45L/H	5962-9561325HMC	AS5C4008ECJ-45L/H	5962-9561325HTC
AS5C4008EC-35/H	5962-9561307HMC	AS5C4008ECJ-35/H	5962-9561307HTC
AS5C4008EC-35L/H	5962-9561321HMC	AS5C4008ECJ-35L/H	5962-9561321HTC
AS5C4008EC-35/H	5962-9561312HMC	AS5C4008ECJ-35/H	5962-9561312HTC
AS5C4008EC-35L/H	5962-9561326HMC	AS5C4008ECJ-35L/H	5962-9561326HTC
AS5C4008EC-25/H	5962-9561308HMC	AS5C4008ECJ-25/H	5962-9561308HTC
AS5C4008EC-25L/H	5962-9561322HMC	AS5C4008ECJ-25L/H	5962-9561322HTC
AS5C4008EC-25/H	5962-9561313HMC	AS5C4008ECJ-25/H	5962-9561313HTC
AS5C4008EC-25L/H	5962-9561327HMC	AS5C4008ECJ-25L/H	5962-9561327HTC
AS5C4008EC-20/H	5962-9561309HMC	AS5C4008ECJ-20/H	5962-9561309HTC
AS5C4008EC-20L/H	5962-9561323HMC	AS5C4008ECJ-20L/H	5962-9561323HTC
AS5C4008EC-17/H	5962-9561310HMC	AS5C4008ECJ-17/H	5962-9561310HTC
AS5C4008EC-17L/H	5962-9561324HMC	AS5C4008ECJ-17L/H	5962-9561324HTC

* ASI part number is for reference only. Orders received referencing the SMD part number will be processed per the SMD.