



Austin Semiconductor, Inc.

SRAM MT5C2565

64K x 4 SRAM SRAM MEMORY ARRAY

AVAILABLE AS MILITARY SPECIFICATIONS

- SMD 5962-89524
- MIL-STD-883

FEATURES

- High Speed: 12, 15, 20, 25, 35, and 45ns
- Battery Backup: 2V data retention
- Low power standby
- High-performance, low-power, CMOS double-metal process
- Single +5V ($\pm 10\%$) Power Supply
- Easy memory expansion with CE\
- All inputs and outputs are TTL compatible

OPTIONS

• Timing

15ns access	-15
20ns access	-20
25ns access	-25
35ns access	-35
45ns access	-45
55ns access	-55*
70ns access	-70*

• Package(s)

Ceramic DIP (300 mil)	C	No.108
Ceramic LCC	EC	No.204

• Operating Temperature Ranges

Industrial (-40°C to +85°C)	IT
Military (-55°C to +125°C)	XT

• 2V data retention/low power L

*Electrical characteristics identical to those provided for the 45ns access devices.

**For more products and information
please visit our web site at
www.austinsemiconductor.com**

PIN ASSIGNMENT (Top View)

28-Pin DIP (C)
(300 MIL)

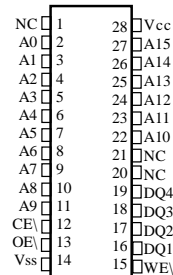

28-Pin LCC (EC)

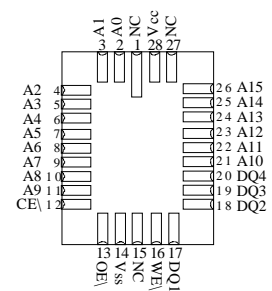

GENERAL DESCRIPTION

The Austin Semiconductor SRAM family employs high-speed, low-power CMOS designs using a four-transistor memory cell. Austin Semiconductor SRAMs are fabricated using double-layer metal, double-layer polysilicon technology.

For flexibility in high-speed memory applications, Austin Semiconductor offers chip enable (CE\) and output enable (OE\) capability. These enhancements can place the outputs in High-Z for additional flexibility in system design. Writing to these devices is accomplished when write enable (WE\) and CE\ inputs are both LOW. Reading is accomplished when WE\ remains HIGH and CE\ and OE\ go LOW. The device offers a reduced power standby mode when disabled. This allows system designs to achieve low standby power requirements.

The "L" version provides an approximate 50 percent reduction in CMOS standby current (I_{SBC2}) over the standard version.

All devices operate from a single +5V power supply and all inputs and outputs are fully TTL compatible.



FUNCTIONAL BLOCK DIAGRAM

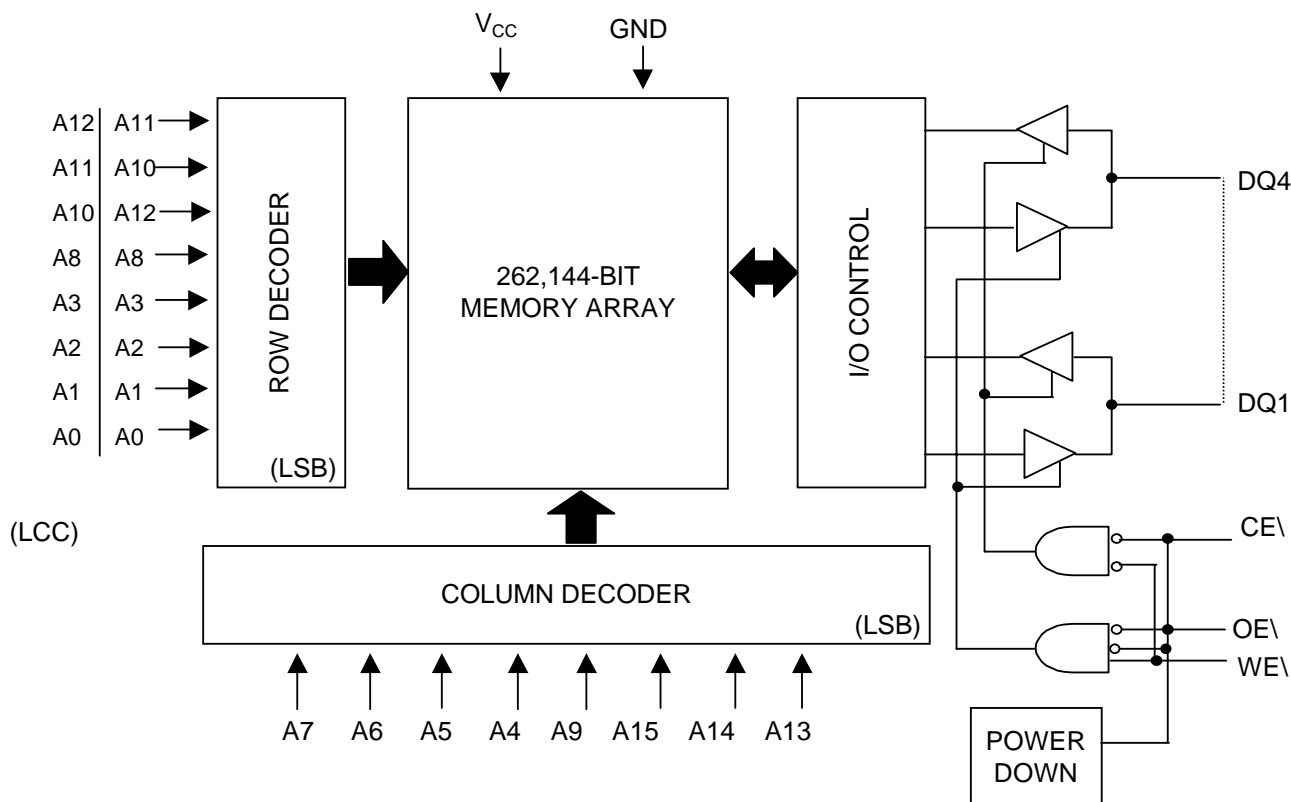

TRUTH TABLE

MODE	OE\	CE\	WE\	DQ	POWER
STANDBY	X	H	X	HIGH-Z	STANDBY
READ	L	L	H	Q	ACTIVE
READ	H	L	H	HIGH-Z	ACTIVE
WRITE	X	L	L	D	ACTIVE



ABSOLUTE MAXIMUM RATINGS*

Voltage on Any Pin Relative to V _{SS}	-0.5V to +7V
Voltage on V _{CC} Supply Relative to V _{SS}	-0.5V to +7V
Storage Temperature.....	-65°C to +150°C
Power Dissipation.....	1W
Short Circuit Output Current.....	50mA
Lead Temperature (soldering 10 seconds).....	+260°C
Junction Temperature.....	+175°C

*Stresses greater than those listed under "Absolute Maximum Ratings" may cause permanent damage to the device. This is a stress rating only and functional operation of the device at these or any other conditions above those indicated in the operation section of this specification is not implied. Exposure to absolute maximum rating conditions for extended periods may affect reliability.

ELECTRICAL CHARACTERISTICS AND RECOMMENDED DC OPERATING CONDITIONS

(-55°C ≤ T_C ≤ 125°C; V_{CC} = 5V ±10%)

DESCRIPTION	CONDITIONS	SYM	MIN	MAX	UNITS	NOTES
Input High (Logic 1) Voltage		V _{IH}	2.2	V _{CC} +0.5	V	1
Input Low (Logic 0) Voltage		V _{IL}	-0.5	0.8	V	1, 2
Input Leakage Current	0V ≤ V _{IN} ≤ V _{CC}	I _{LI}	-10	10	μA	
Output Leakage Current	Output(s) disabled 0V ≤ V _{OUT} ≤ V _{CC}	I _{LO}	-10	10	μA	
Output High Voltage	I _{OH} =-4.0mA	V _{OH}	2.4		V	1
Output Low Voltage	I _{OL} =8.0mA	V _{OL}		0.4	V	1

PARAMETER	CONDITIONS	SYM	MAX					UNITS	NOTES
			-15	-20	-25	-35	-45		
Power Supply Current: Operating	CE\ ≤ V _{IL} ; V _{CC} = MAX f = MAX = 1/t _{RC} (MIN) Output Open	I _{CC}	160	150	120	120	120	mA	3
Power Supply Current: Standby	CE\ = 2.4V, OE\ = 2.4V, V _{CC} = MAX, f = 0 Hz	I _{SBT2}	40	40	20	20	20	mA	
	CE\ ≥ V _{CC} -0.3V; V _{CC} = MAX V _{IL} ≤ V _{SS} +0.2V V _{IH} ≥ V _{CC} -0.2V; f = 0 Hz	I _{SBC2}	20	20	10	10	10	mA	
	"L" Version Only	I _{SBC2}	10	10	10	10	10	mA	

CAPACITANCE

DESCRIPTION	CONDITIONS	SYM	MAX	UNITS	NOTES
Input Capacitance	T _A = 25°C, f = 1MHz	C _I	11	pF	4
Output Capacitance	V _{CC} = 5V	C _O	11	pF	4



ELECTRICAL CHARACTERISTICS AND RECOMMENDED AC OPERATING CONDITIONS

(Note 5) (-55°C ≤ T_c ≤ 125°C; V_{cc} = 5V ±10%)

DESCRIPTION	SYMBOL	-15		-20		-25		-35		-45		UNITS	NOTES
		MIN	MAX	MIN	MAX	MIN	MAX	MIN	MAX	MIN	MAX		
READ CYCLE													
READ cycle time	t _{RC}	15		20		25		35		45		ns	
Address access time	t _{AA}		15		20		25		35		45	ns	
Chip Enable access time	t _{ACE}		15		20		25		35		45	ns	
Output hold from address change	t _{OH}	3		3		3		3		3		ns	
Chip Enable to output in Low-Z	t _{LZCE}	3		3		3		3		3		ns	7
Chip disable to output in High-Z	t _{HZCE}		8		10		15		15		20	ns	6, 7
Output Enable access time	t _{AOE}		8		10		15		25		30	ns	4
Output Enable to output in Low-Z	t _{LZOE}	0		0		0		0		0		ns	4
Output disable to output in High-Z	t _{HZOE}		9		9		15		20		20		
WRITE CYCLE													
WRITE cycle time	t _{WC}	15		20		25		35		45		ns	
Chip Enable to end of write	t _{CW}	10		15		20		25		30		ns	
Address valid to end of write	t _{AW}	10		15		20		25		30		ns	
Address setup time	t _{AS}	0		0		0		0		0		ns	
Address hold from end of write	t _{AH}	0		0		0		0		0		ns	
WRITE pulse width	t _{WP}	10		15		20		25		30		ns	
Data setup time	t _{DS}	9		10		15		20		20		ns	
Data hold time	t _{DH}	0		0		0		0		0		ns	
Write disable to output in Low-Z	t _{LZWE}	0		0		0		0		0		ns	7
Write Enable to output in High-Z	t _{HZWE}		7		10		15		15		20	ns	6, 7



ACTEST CONDITIONS

Input pulse levels	V _{ss} to 3.0V
Input rise and fall times	5ns
Input timing reference levels	1.5V
Output reference levels	1.5V
Output load	See Figures 1 and 2

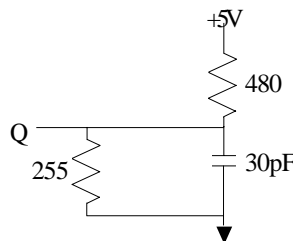

Fig. 1 Output Load Equivalent

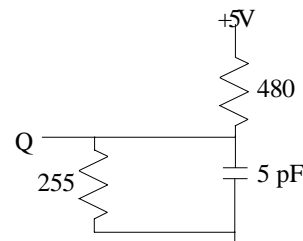

Fig. 2 Output Load Equivalent

NOTES

- All voltages referenced to V_{ss} (GND).
- 3V for pulse width < 20ns
- I_{CC} is dependent on output loading and cycle rates. The specified value applies with the outputs unloaded, and $f = \frac{1}{t_{RC}(\text{MIN})}$ Hz.
- This parameter is guaranteed but not tested.
- Test conditions as specified with the output loading as shown in Fig. 1 unless otherwise noted.
- t_{HZCE}, t_{HZOE} and t_{HZWE} are specified with CL = 5pF as in Fig. 2. Transition is measured ±500mV typical from steady state voltage, allowing for actual tester RC time constant.
- At any given temperature and voltage condition, t_{HZCE} is less than t_{LZCE}, and t_{HZWE} is less than t_{LZWE} and t_{HZOE} is less than t_{LZOE}.
- WE\ is HIGH for READ cycle.
- Device is continuously selected. Chip enable is held in its active state.
- Address valid prior to, or coincident with, latest occurring chip enable.
- t_{RC} = Read Cycle Time.
- Chip enable (CE\) and write enable (WE\) can initiate and terminate a WRITE cycle.

DATA RETENTION ELECTRICAL CHARACTERISTICS (L Version Only)

DESCRIPTION	CONDITIONS	SYM	MIN	MAX	UNITS	NOTES
V _{CC} for Retention Data	CE\ ≥ (V _{CC} - 0.2V)	V _{DR}	2	---	V	
Data Retention Current	V _{IN} ≥ (V _{CC} - 0.2V) or ≤ 0.2V	I _{CCDR}		1	mA	*
Chip Deselect to Data Retention Time		t _{CDR}	0	---	ns	4
Operation Recovery Time		t _R	t _{RC}		ns	4, 11

*for -25 and slower only

LOW V_{CC} DATA RETENTION WAVEFORM

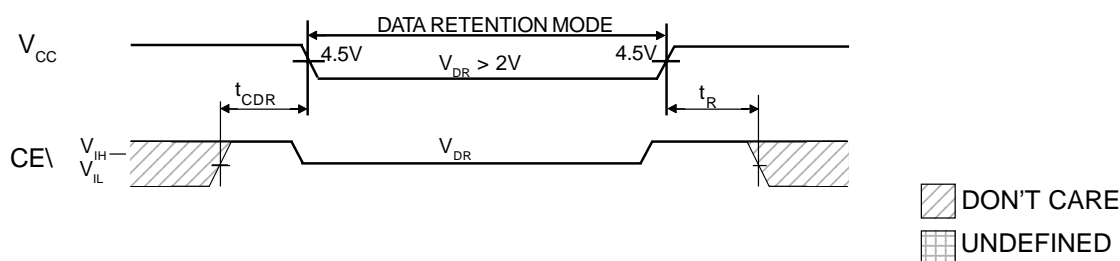



READ CYCLE NO. 1 ^{8,9}

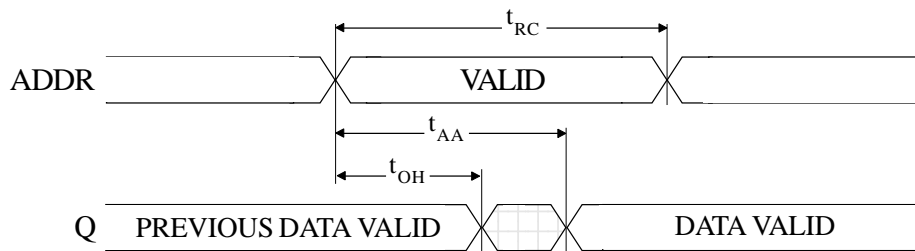

READ CYCLE NO. 2 ^{7,8,10}

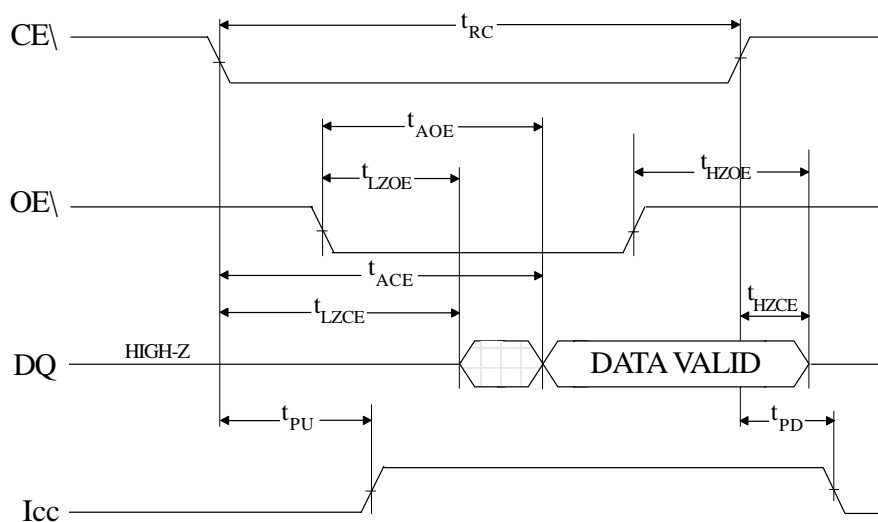



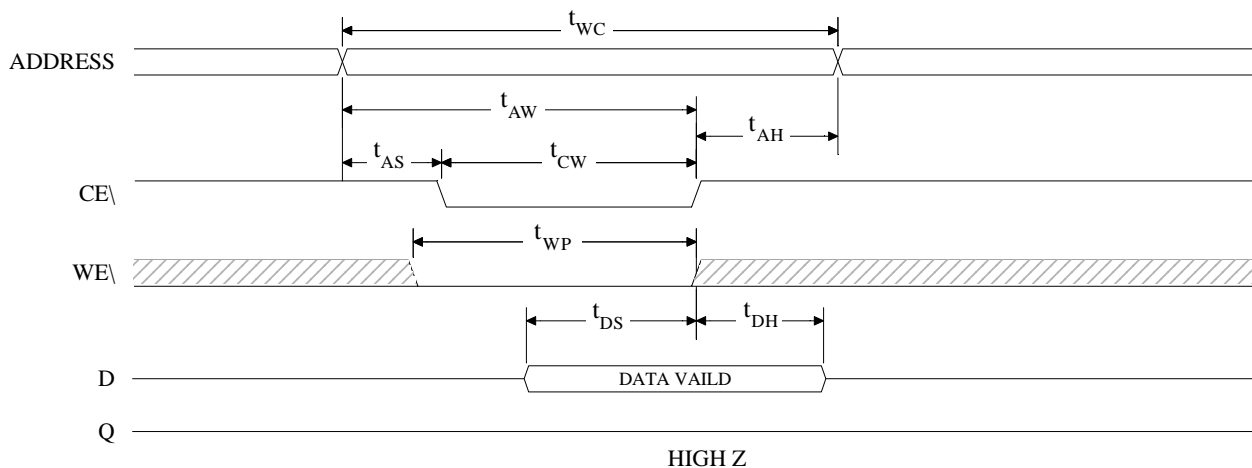

WRITE CYCLE NO. 1 ¹²
(Chip Enabled Controlled)

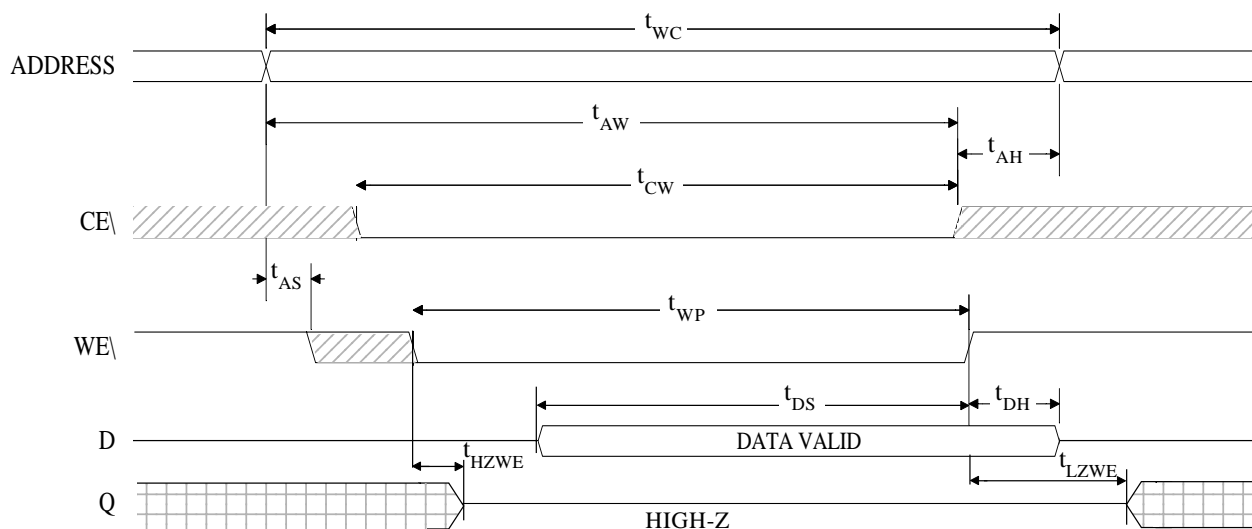

WRITE CYCLE NO. 2 ^{7, 12}
(Write Enabled Controlled)



NOTE: Output enable (OE) is inactive (HIGH).

 DON'T CARE
 UNDEFINED



MECHANICAL DEFINITIONS*

**ASI Case #108 (Package Designator C)
SMD #5962-89524, Case Outline X**

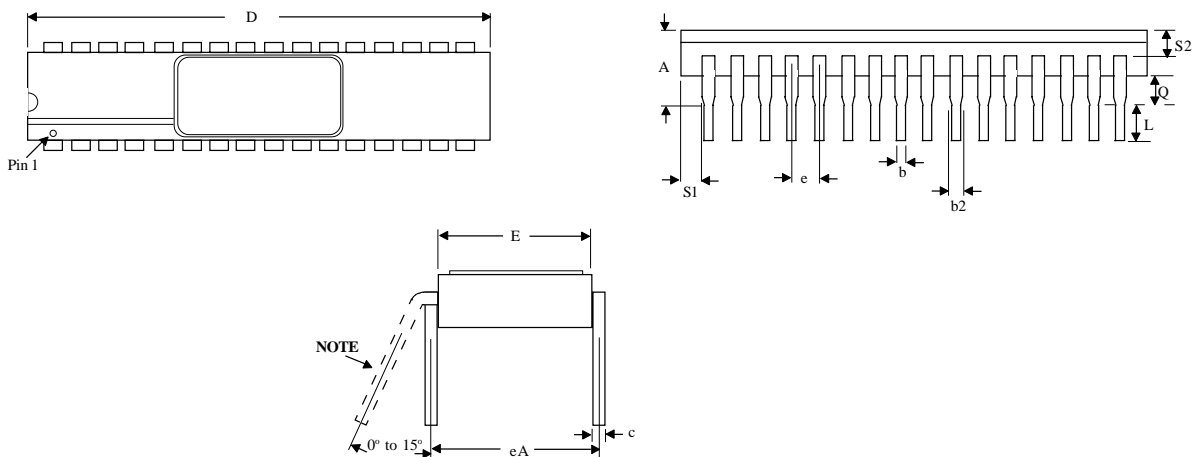

SYMBOL	SMD SPECIFICATIONS	
	MIN	MAX
A	---	0.225
b	0.014	0.026
b2	0.045	0.065
c	0.008	0.018
D	---	1.485
E	0.240	0.310
eA	0.300 BSC	
e	0.100 BSC	
L	0.125	0.200
Q	0.015	0.070
S1	0.005	---
S2	0.005	---

NOTE: *These dimensions are per the SMD. ASI's package dimensional limits may differ, but they will be within the SMD limits.*

*All measurements are in inches.



MECHANICAL DEFINITIONS*

ASI Case #204 (Package Designator EC)
SMD# 5962-88681, Case Outline X

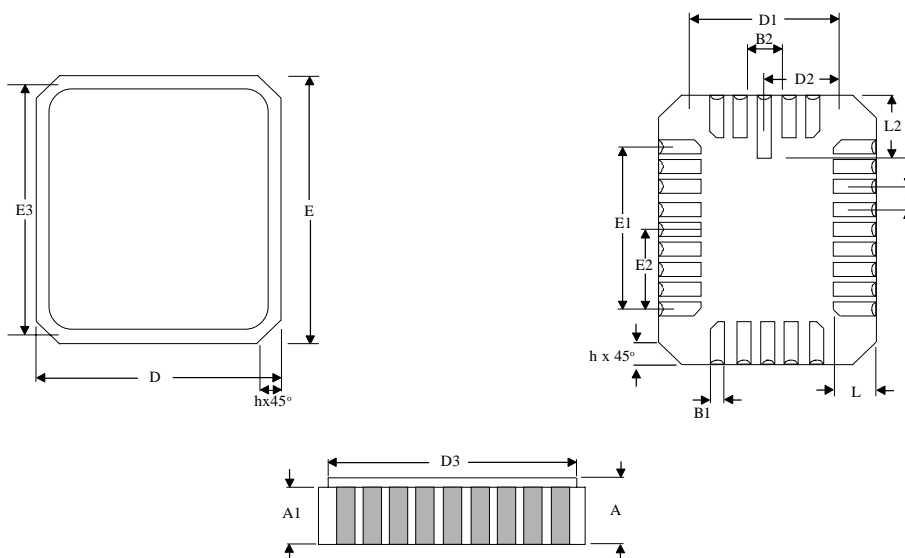

SYMBOL	SMD SPECIFICATIONS	
	MIN	MAX
A	0.060	0.120
A1	0.050	0.088
B1	0.022	0.028
B2	0.072 REF	
D	0.342	0.358
D1	0.200 BSC	
D2	0.100 BSC	
D3	---	0.358
E	0.540	0.560
E1	0.400 BSC	
E2	0.200 BSC	
E3	---	0.558
e	0.050 BSC	
h	0.040 REF	
L	0.045	0.055
L2	0.075	0.095

NOTE: These dimensions are per the SMD. ASI's package dimensional limits may differ, but they will be within the SMD limits.

*All measurements are in inches.



ORDERING INFORMATION

EXAMPLE: MT5C2565C-20L/IT

Device Number	Package Type	Speed ns	Options**	Process
MT5C2565	C	-15	L	/*
MT5C2565	C	-20	L	/*
MT5C2565	C	-25	L	/*
MT5C2565	C	-35	L	/*
MT5C2565	C	-45	L	/*
MT5C2565	C	-55	L	/*
MT5C2565	C	-70	L	/*

EXAMPLE: MT5C2565EC-45/XT

Device Number	Package Type	Speed ns	Options**	Process
MT5C2565	EC	-15	L	/*
MT5C2565	EC	-20	L	/*
MT5C2565	EC	-25	L	/*
MT5C2565	EC	-35	L	/*
MT5C2565	EC	-45	L	/*
MT5C2565	EC	-55	L	/*
MT5C2565	EC	-70	L	/*

*AVAILABLE PROCESSES

IT = Industrial Temperature Range
 XT = Extended Temperature Range
 883C = Full Military Processing

-40°C to +85°C
 -55°C to +125°C
 -55°C to +125°C

** OPTIONS

L = 2V Data Retention/Low Power



**ASI TO DSCC PART NUMBER
CROSS REFERENCE***

ASI Package Designator C

<u>ASI Part #</u>	<u>SMD Part #</u>
MT5C2565C-15/883C	5962-8952407XX
MT5C2565C-20/883C	5962-8952406XX
MT5C2565C-25/883C	5962-8952405XX
MT5C2565C-35/883C	5962-8952404XX
MT5C2565C-45/883C	5962-8952403XX
MT5C2565C-55/883C	5962-8952402XX
MT5C2565C-70/883C	5962-8952401XX

ASI Package Designator EC

<u>ASI Part #</u>	<u>SMD Part #</u>
MT5C2565EC-15/883C	5962-8952407YX
MT5C2565EC-20/883C	5962-8952406YX
MT5C2565EC-25/883C	5962-8952405YX
MT5C2565EC-35/883C	5962-8952404YX
MT5C2565EC-45/883C	5962-8952403YX
MT5C2565EC-55/883C	5962-8952402YX
MT5C2565EC-70/883C	5962-8952401YX

* ASI part number is for reference only. Orders received referencing the SMD part number will be processed per the SMD.