

AZ DISPLAYS, INC.

Complete LCD Solutions

ACM2402D SERIES LCD MODULE

1.0 PHYSICAL DATA

Item	Nominal Dimensions / Available Options	Unit
Number of Characters	24 characters x 2 lines	-
Character Format	5 x 7 dots with cursor	-
Overall Module Size (W x H x D)	190.0 x 42.0 x max 13.5 for LED backlight version 190.0 x 42.0 x max 9.5 for reflective version	mm
Dot Size (W x H)	1.00 x 1.00	mm
Dot Pitch (W x H)	1.10 x 1.10	mm
Duty	1/16	-
Controller IC	KS0066	-
LC Fluid Options	STN	-
Polarizer Options	Reflective, Transflective	-
Backlight Options	LED	-
Temperature Range Options	Standard	-

2.0 ABSOLUTE MAXIMUM RATINGS

Item	Symbol	Min	Typ	Max	Unit
Operating temperature (Standard)	Top	0	-	50	°C
Storage temperature (Standard)	Tst	-20	-	70	°C
Input voltage	Vi	Vss	-	VDD	V
Supply voltage for logic	VDD-VSS	0	5.0	6.5	V
Supply voltage for LCD drive	VDD-VO	0	-	6.5	V

3.0 OPTICAL CHARACTERISTICS (Ta = 25°C, VDD = 5.0V ± 0.25V, STN LC Fluid)

Item	Symbol	Condition	Min	Typ	Max	Unit
Viewing angle (horizontal)	θ	$Cr \geq 2.0$	± 30	-	± 45	deg
Viewing angle (vertical)	ϕ	$Cr \geq 2.0$	60	-	80	deg
Contrast Ratio	Cr	$\phi=0^\circ, \theta=0^\circ$	4.5	-	10	
Response time (rise)	Tr	$\phi=0^\circ, \theta=0^\circ$	-	120	240	ms
Response time (fall)	Tf	$\phi=0^\circ, \theta=0^\circ$	-	155	310	ms

ACM2402D SERIES LCD MODULE

4.0 ELECTRICAL CHARACTERISTICS (Ta = 25°C, VDD = 5.0V ± 0.25V)

Item	Symbol	Condition	Min	Typ	Max	Unit
Supply voltage for LCD drive	VDD-VO	Ta = 25°C		4.8		V
Input voltage	VI	-	4.75	5.0	5.25	V
Input high voltage	VIH	-	2.2	-	VDD	V
Input low voltage	VIL	-	0	-	0.6	V
Output high voltage	VOH	IOH=0.2mA	2.4	-	-	V
Output low voltage	VOL	IOL=1.2mA	-	-	0.4	V
Supply current	IDD	VDD=5.0V	-		3.0	mA
Input leakage current	ILKG	-	-	-	1.0	uA
LED power supply current	ILED	VLED=5V, R=2.7Ω	-	300	-	mA

5.0 INTERFACE PIN CONNECTIONS

Pin No.	Symbol	Level	Pin Description	Function
1	VSS	-	Ground	0V
2	VDD	-	Supply voltage for logic	+5V
3	Vo	-	LCD contrast adjust	By user
4	RS	H/L	Register select	H: Data; L: Instruction code
5	R/W	H/L	Read / write	H: Data read, L: Data write
6	E	H, H→L	Enable	Start signal for data read/write
7	DB0	H/L	Data bit 0	8-bit interface
8	DB1	H/L	Data bit 1	8-bit interface
9	DB2	H/L	Data bit 2	8-bit interface
10	DB3	H/L	Data bit 3	8-bit interface
11	DB4	H/L	Data bit 4	4-bit or 8-bit interface
12	DB5	H/L	Data bit 5	4-bit or 8-bit interface
13	DB6	H/L	Data bit 6	4-bit or 8-bit interface
14	DB7	H/L	Data bit 7	4-bit or 8-bit interface
-	A	-	Anode for LED backlight	Power supply for LED backlight
-	K	-	Cathode for LED backlight	Power supply for LED backlight

ACM2402D SERIES LCD MODULE

6.0 POWER SUPPLY

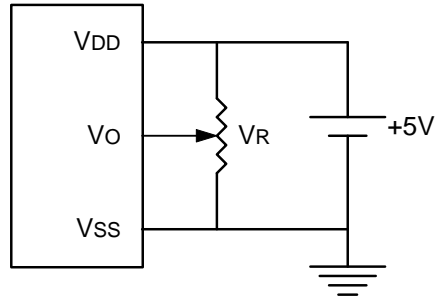

$V_R = 10K\Omega \sim 20K\Omega$

7.0 BLOCK DIAGRAM

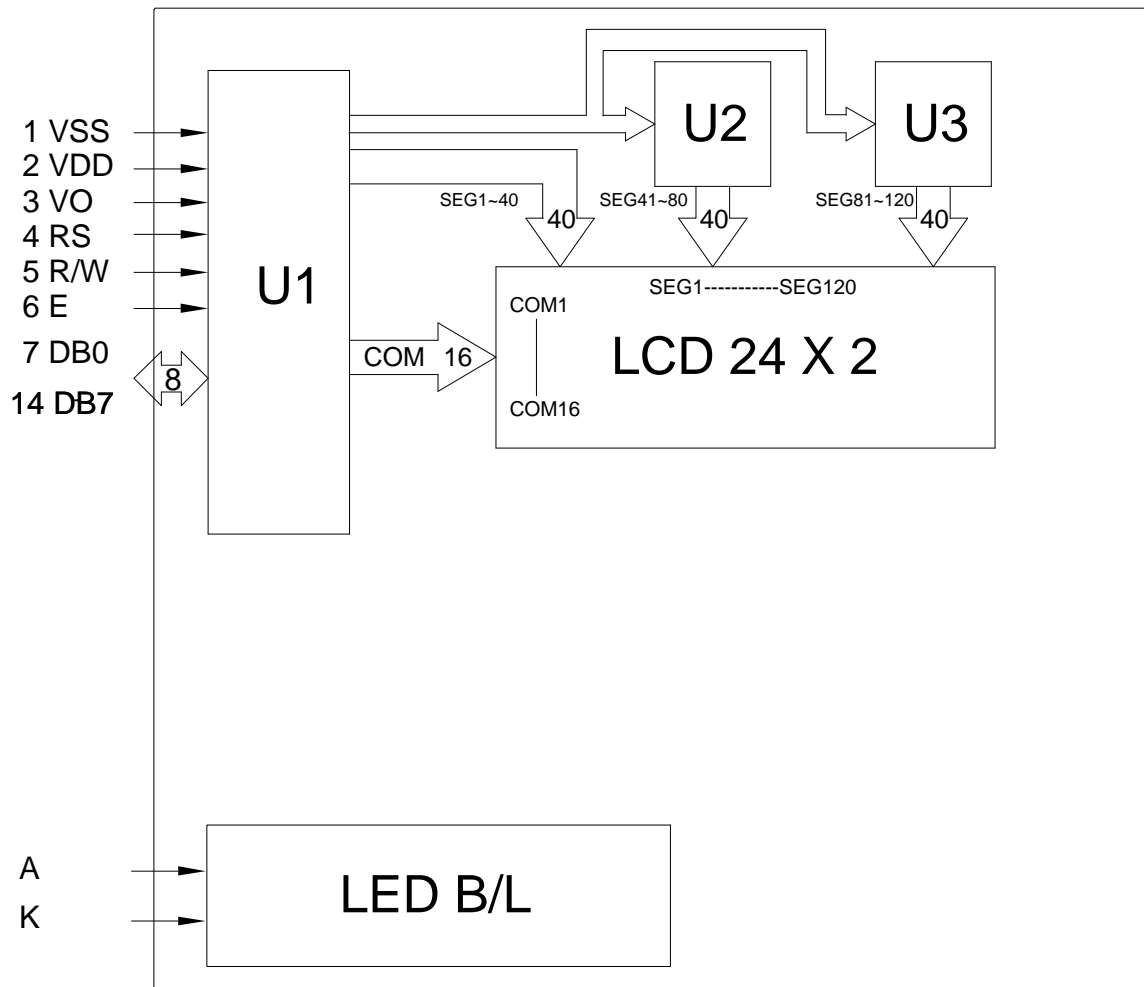

ACM2402D SERIES LCD MODULE

8.0 TIMING CHARACTERISTICS (KS0066 Controller)

Item	Symbol	Test Condition	Min.	Typ.	Max.	Unit
Enable cycle time	t_{CYC}	Fig. a, Fig. b	500	-	-	ns
Enable pulse width	PW_{EH}	Fig. a, Fig. b	220	-	-	ns
Enable rise/fall time	t_{Er} , t_{Ef}	Fig. a, Fig. b	-	-	25	ns
RS, R/W set up time	t_{AS}	Fig. a, Fig. b	40	-	-	ns
RS, R/W hold time	t_{H1}	Fig. a, Fig. b	10	-	-	ns
Data set up time	t_{DSW}	Fig. a	60	-	-	ns
Data hold time	t_{H2}	Fig. a	10	-	-	ns
Data delay time	t_{DDR}	Fig. b	-	-	120	ns
Data hold time	t_{H2}	Fig. b	20	-	-	ns

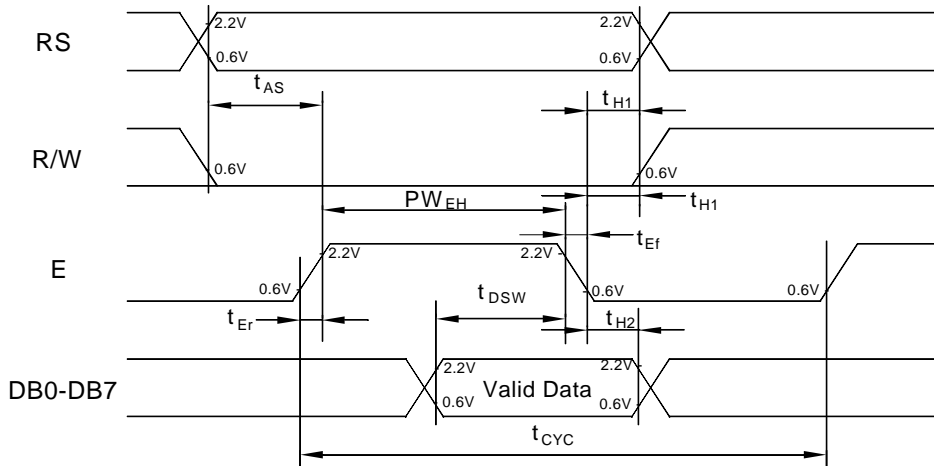

Fig. a Interface timing (data write)

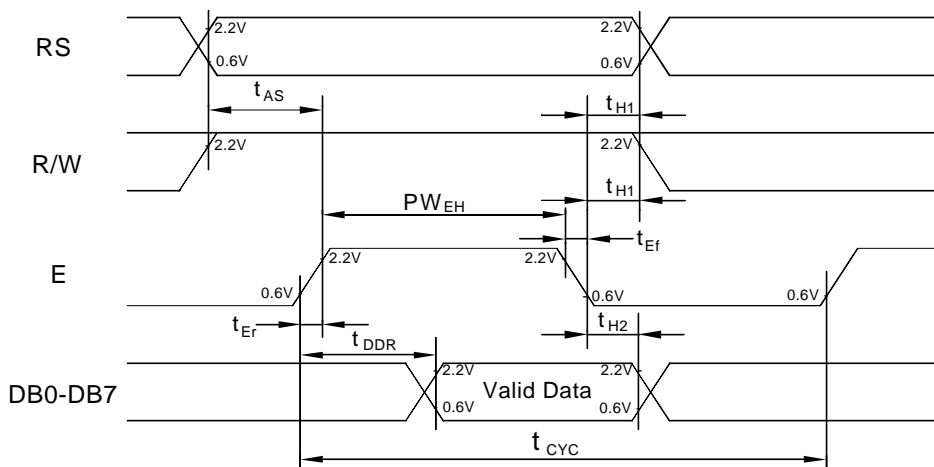

Fig. b Interface timing (data read)

