

AZ DISPLAYS, INC.

1. MECHANICAL DATA

(1) Part Name	AGM1616B
(2) Module Size	70.5(W)mm X90.5(H)mm X 10.8(D)mm (EL B/L)
(3) Dot Size	0.335 (W)mm x 0.335 (H)mm
(4) Dot Pitch	0.350 (W)mm x 0.350 (H)mm
(5) Number of Dots	160 (W) x 160 (H)Dots
(6) Duty	1/160
(7) LCD Display Mode	STN: <input type="checkbox"/> Normally White <input type="checkbox"/> Normally White(Special Lighter Background Color)
	Rear Polarizer: <input type="checkbox"/> Transflective(Normal) <input type="checkbox"/> Transflective(3M)
(8) Viewing Direction	6 O'clock
(9) Controller	Excluded
(10) Backlight	EL B/L (BLUE GREEN)
(11) Weight	47.9 g (approx)

Revised: October 26, 2001

2. ABSOLUTE MAXIMUM RATINGS

(1) ELECTRICAL ABSOLUTE RATINGS

V_{SS}=0V Standard

ITEM	SYMBOL	MIN	MAX	UNIT	COMMENT
Power Supply for Logic	VDD-VSS	-0.3	7.0	V	
Power Supply For LC Drive	VEE-VSS	-0.3	30	V	
Input Voltage	V _I	-0.3	VDD+0.3	V	
Static Electricity	-	-	-	-	Note 1

Note 1 : LCM should be grounded during handling LCM.

(2) ENVIRONMENTAL ABSOLUTE MAXIMUM RATINGS

ITEM	OPERATING		STORAGE	
	MIN.	MAX.	MIN.	MAX.
Ambient Temperature	0	50	-20	70
Humidity (Without Condensation)	Note 2,4		Note 3,4	

Note 2 : Ta ≤ 50°C : 85%RH max
 Ta > 50°C : Absolute humidity must be lower
 than the humidity of 85%RH at 50°C

Note 3 : Ta at -20°C will be < 48hrs, at 70°C will be < 120 hrs

Note 4 : Background color will change slightly depending on ambient temperature.
 This phenomenon is reversible.

3. ELECTRICAL CHARACTERISTICS

(VDD= 3.3V ± 5%)

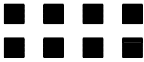
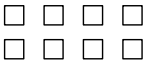
ITEM		SYMBOL	CONDITION		MIN.	TYP.	MAX.	UNIT
Input Voltage		VIH	H level		0.8VDD	—	VDD	V
		VIO	L level		0	—	0.2VDD	V
Recommended LC Driving Voltage		VEE-VSS (Vop)	1/160 Duty	0°C	20.7	21.0	21.3	V
				25°C	20.2	20.5	20.8	
			1/13 Bias	50°C	19.3	19.6	19.9	
Power Supply Current		IDD	VDD=3.3V VSS=0V VEE=20.5V FLM=70Hz		—	0.03	0.05	mA
		IEE			—	1.0	1.5	
Power Supply Current For EL		BATTERY+	BATTERY+= 3.3V EL_ON= 3.3V (VEL=55V,125Hz)		—	17.5	26.3	mA
LCM	Surface Luminance	L	VDD= 3.3V VSS= 0V VEE-VSS= 20.5V BATTERY+= 3.3V EL_ON= 3.3V	PATTERN: (Dots All On) 	—	0.99	—	cd/m ²
				PATTERN: (Dots All Off) 	—	0.12	—	

4. OPTICAL CHARACTERISTICS

AT Vop

ITEM MODE		Cr(Contrast Ratio)						θ (Viewing Angle)		ϕ (Viewing Angle)	
		0°C		25°C		50°C		25°C		25°C	
		MIN.	TYP.	MIN.	TYP.	MIN.	TYP.	MIN.	TYP.	MIN.	TYP.
S	J	2	10	2	12	2	8	-	83	-	38
M	L	7.6	7.9	8.3	8.6	6.2	6.5	-	83	-	38
Note		NOTE 6						NOTE 5			

NOTE :

S: TRANSFLECTIVE

J: NORMALLY WHITE

M: TRANSFLECTIVE(3M)

L: NORMALLY WHITE(SPECIAL LIGHTER
BACKGROUND COLOR)

AT $\phi=0^\circ$ $\theta=0^\circ$

ITEM	SYMBOL	CONDITION	MIN.	TYP.	MAX.	UNIT	NOTE
Response Time (rise)	Tr	0°C	350	700	1100	ms	NOTE 2
		25°C	120	250	380		
		50°C	50	100	150		
Response Time (fall)	Tf	0°C	150	300	450	ms	NOTE 2
		25°C	50	100	150		
		50°C	20	40	60		

(NOTE 1)

Definition of Operation Voltage(Vop)

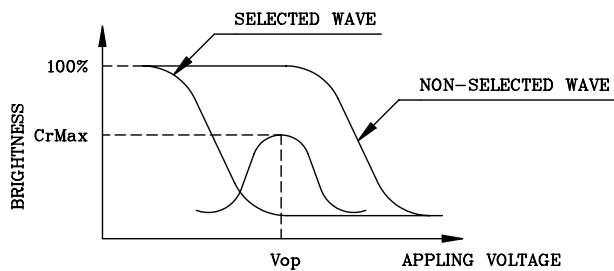

(positive type)

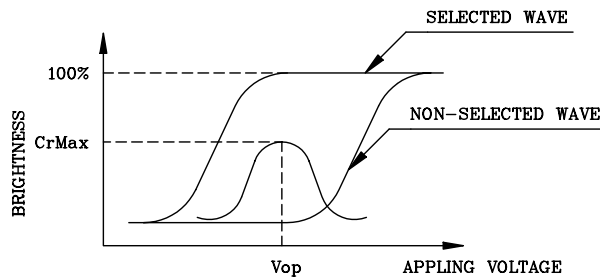

(negative type)

*Conditions

- Viewing Angle : 0
- Frame Frequency : 70Hz
- Applying Waveform : 1/N duty 1/a bias

(NOTE 2)

Definition of Response Time(Tr,Tf)

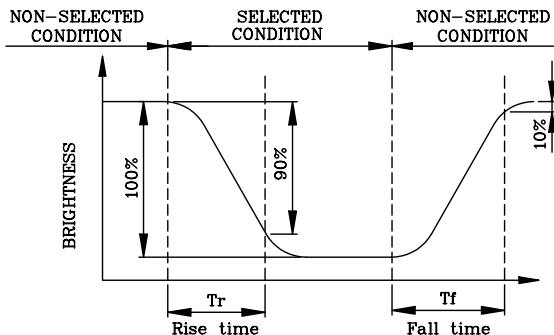

(positive type)

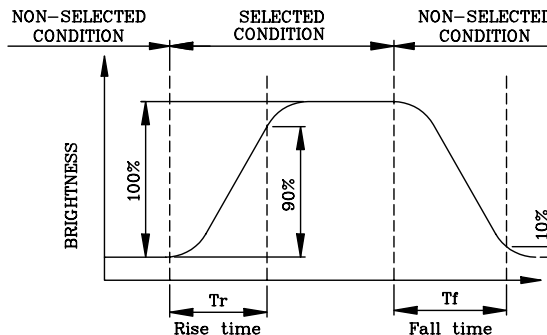

(negative type)

*Conditions

- Operating Voltage : Vop
- Viewing Angle (θ, ϕ) : (0,0)
- Frame Frequency : 70Hz
- Applying Waveform : 1/N duty 1/a bias

(NOTE 3)

Description of Measuring Equipment and Driving Waveforms

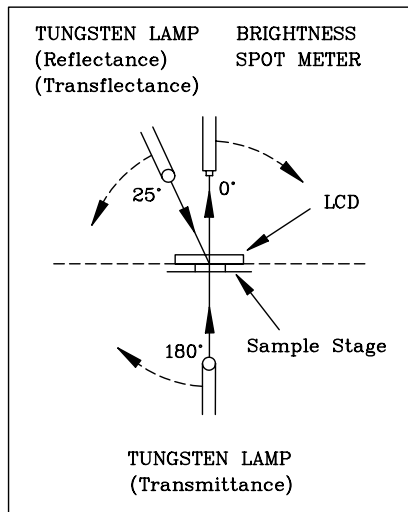

CONST.
TEMP.
CHAMBER

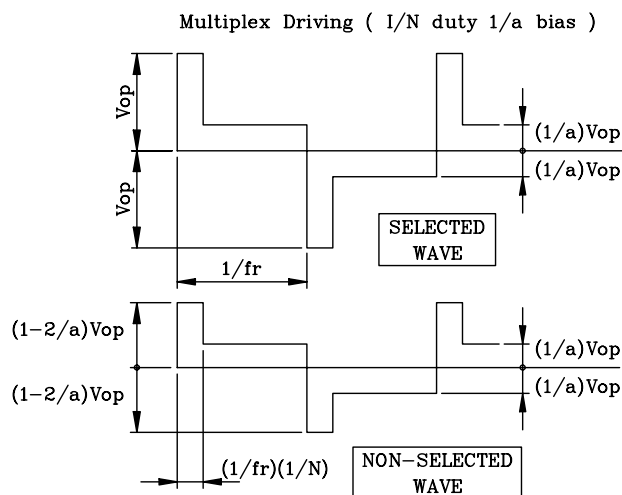

(NOTE 4)

Definition of Viewing Direction

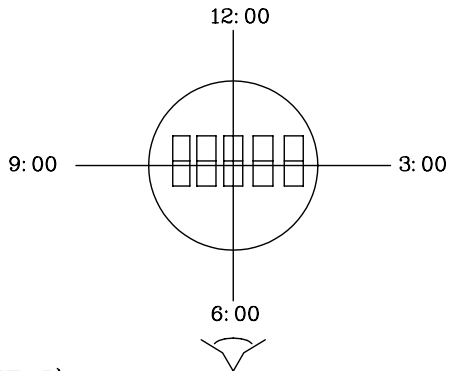

(NOTE 5)

Definition of Viewing Angle

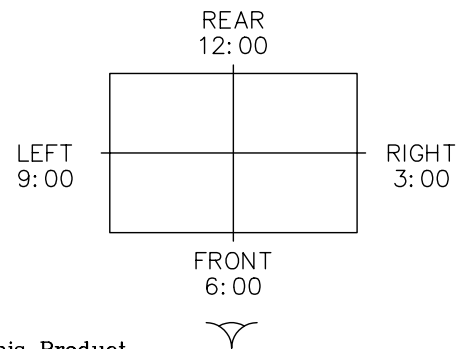
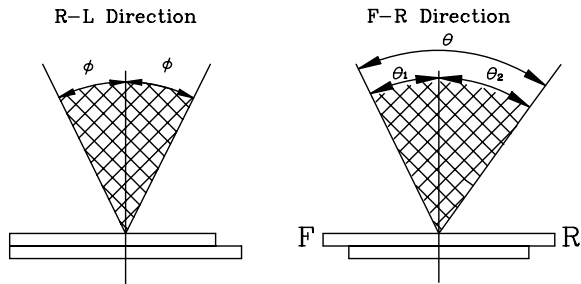

*For This Product
The Viewing Direction Is 6 O'clock
So $\theta_1 > \theta_2$

$$\theta = \theta_1 + \theta_2$$

*Conditions

Operating Voltage : Vop
Frame Frequency : 70Hz
Applying Waveform : 1/N duty 1/a bias
Contrast Ratio : larger than 2

(NOTE 6)

Definition of Contrast Ratio (Cr)

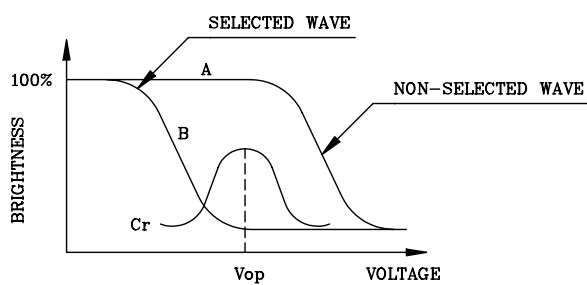

(positive type)

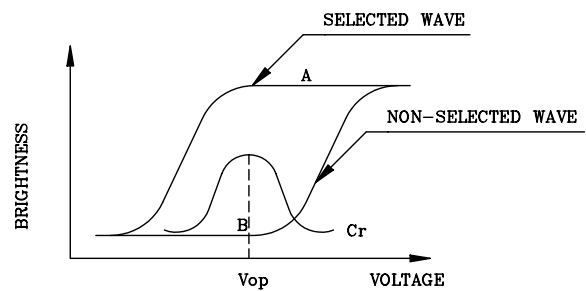

(negative type)

$$\text{Contrast Ratio : } Cr = A/B$$

*Conditions

Viewing Angle : 0
Frame Frequency : 70Hz
Applying Waveform : 1/N duty 1/a bias

5. BLOCK DIAGRAM

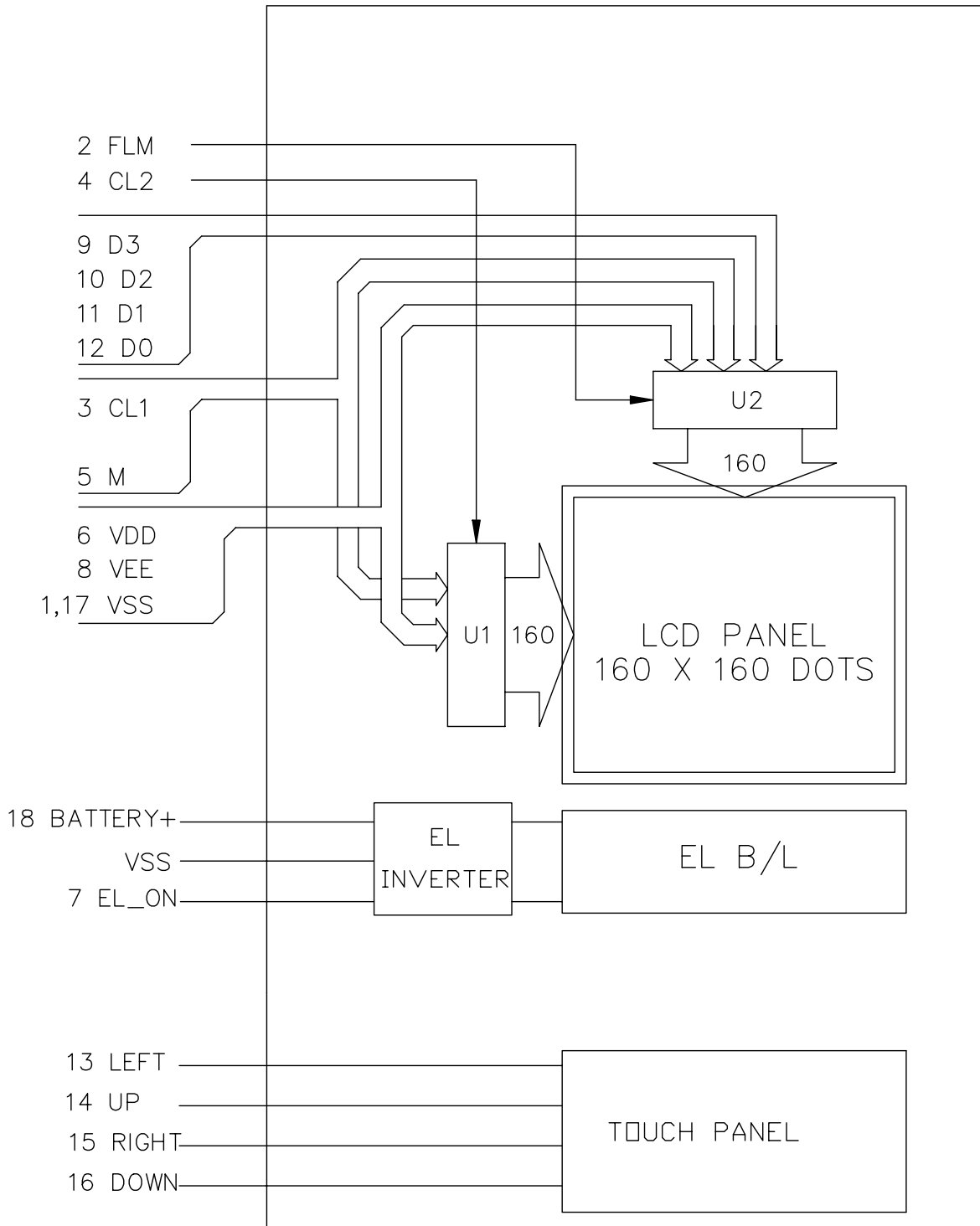

6. INTERNAL PIN CONNECTION

FFC,18Pins,Pitch 1.0 mm

Pin No.	Symbol	Function
1	VSS	Power Supply (0V)
2	FLM(EI02)	First Line Mark for Common Scan
3	CL1(LP)	H → L DATA Latch Pulse
4	CL2(XCK)	Clock Pules for Segment shift regieter
5	M(FR)	H/L Frame Reverse Signal
6	VDD	H/L Supply for logic (+3.3V)
7	EL ON	EL Back Light ON/OFF ("H"=ON,"L"=OFF)
8	VEE	Power Supply for LCD
9	D3	H/L Display Data
10	D2	H/L Display Data
11	D1	H/L Display Data
12	D0	H/L Display Data
13	LEFT	Touch Panel Connection
14	UP	
15	RIGHT	
16	DOWN	
17	VSS	Power Supply (0V)
18	BATTERY+	Power Supply For EL Backlight

Mating Connector : MOLEX 52807-1810 or COMPATIBLE

7. POWER SUPPLY

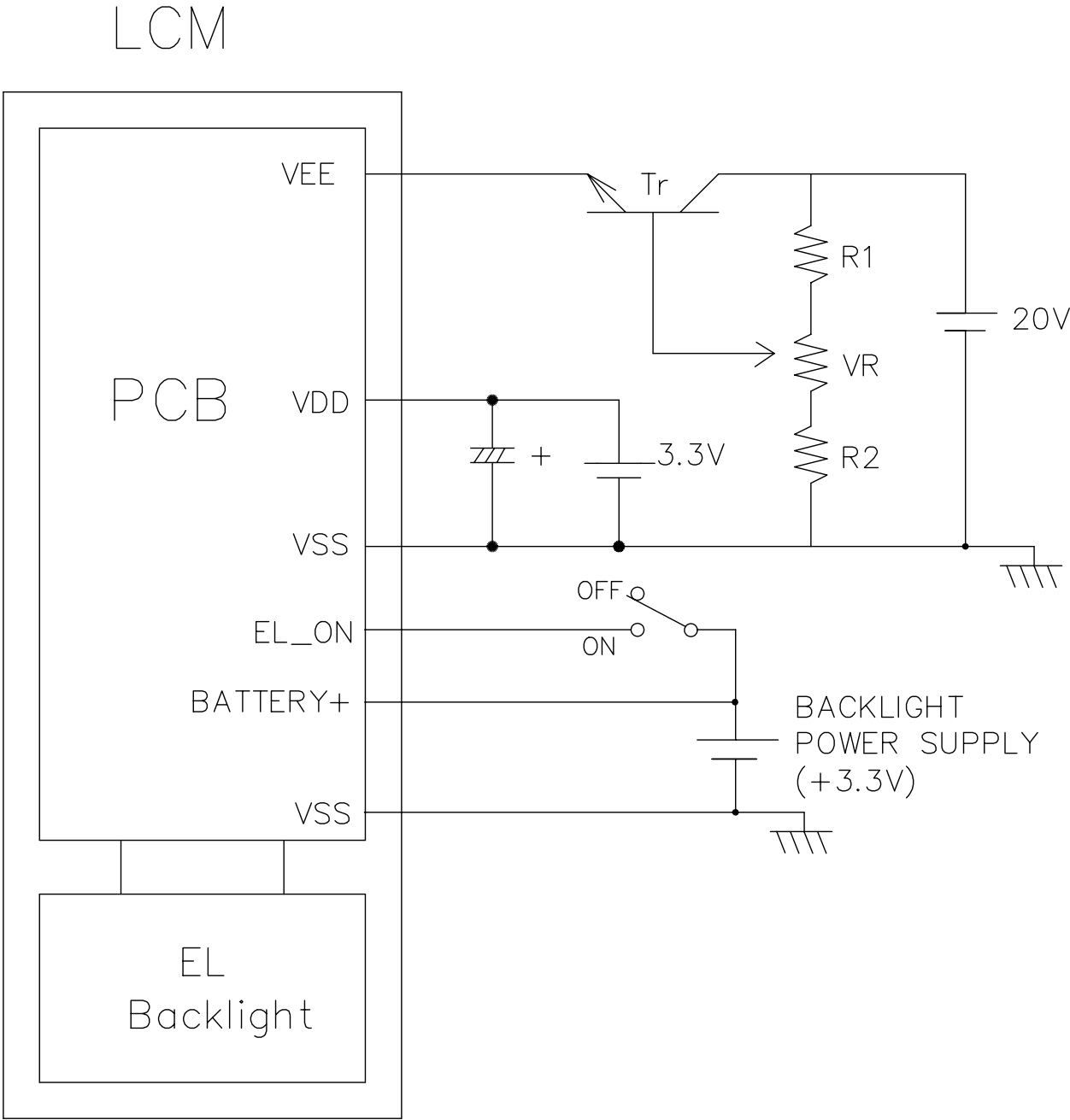

NOTE :

1. $R1 + R2 + VR = 10 \sim 20K \Omega$

8. TIMING CHARACTERISTICS

8-1. INTERFACE TIMING

@ VDD=3.0V±5%, Ta=-20~85 °C

Item	Symbol	Test condition	Min.	Typ.	Max.	Unit
CL2 Cycle Time	tC	Fig. a	125	-	-	ns
CL2 Pulse Width	tSWH,tSWL	Fig. a	51	-	-	ns
CL2 Rise/Fall Time	tCR,tCF	Fig. a	-	-	50	ns
Data Set Up Time	tDSU	Fig. a	30	-	-	ns
Data Hold Time	tDHD	Fig. a	40	-	-	ns
CL1 Cycle Time	tL	Fig. b	250	-	-	ns
CL1 "H" Pulse Width	tLWH	Fig. a , Fig. b	51	-	-	ns
CL1 Rise/Fall Time	tLR,tLF	Fig. b	-	-	50	ns
CL2 To CL1 Delay Time	tCL	Fig. a	51	-	-	ns
CL1 To CL2 Delay Time	tLC	Fig. a	51	-	-	ns
FLM TO CL1 SETUP TIME	tFLS	Fig. b	30	-	-	ns
FLM TO CL1 HOLD TIME	tFLH	Fig. b	50	-	-	ns

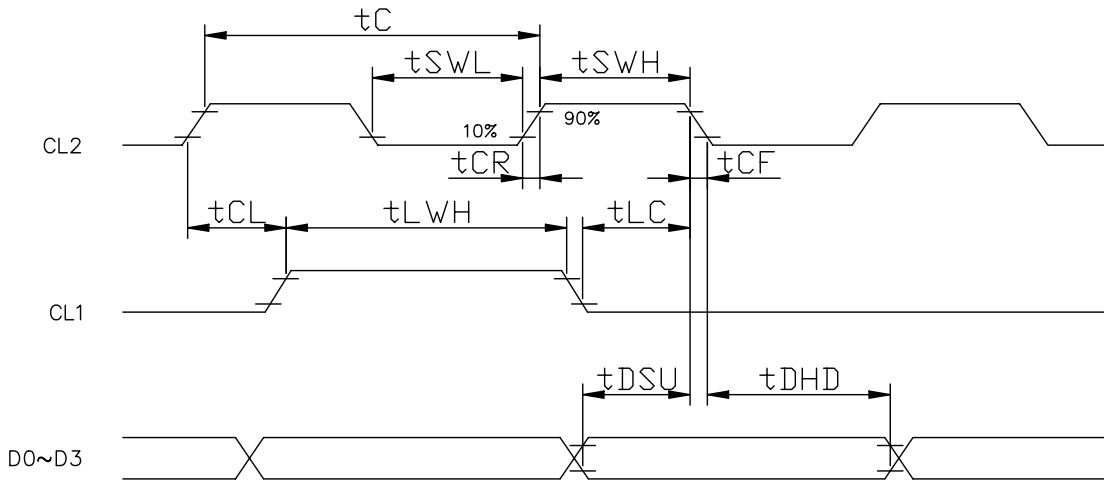

Fig . a Interface timing (SEGMENT)

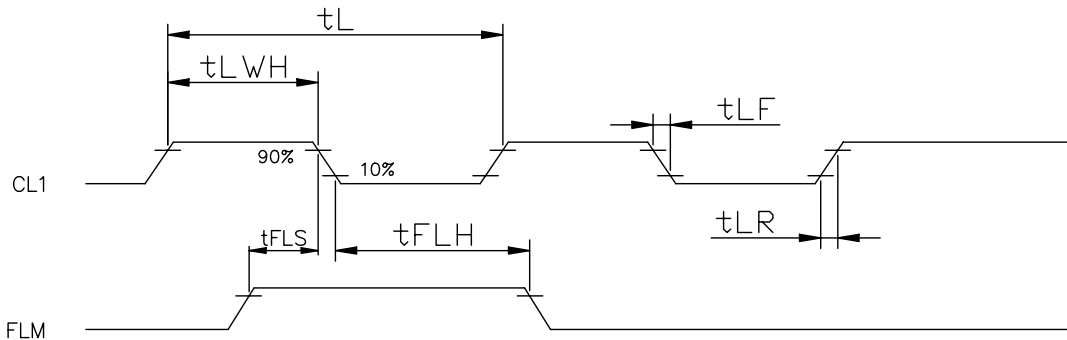
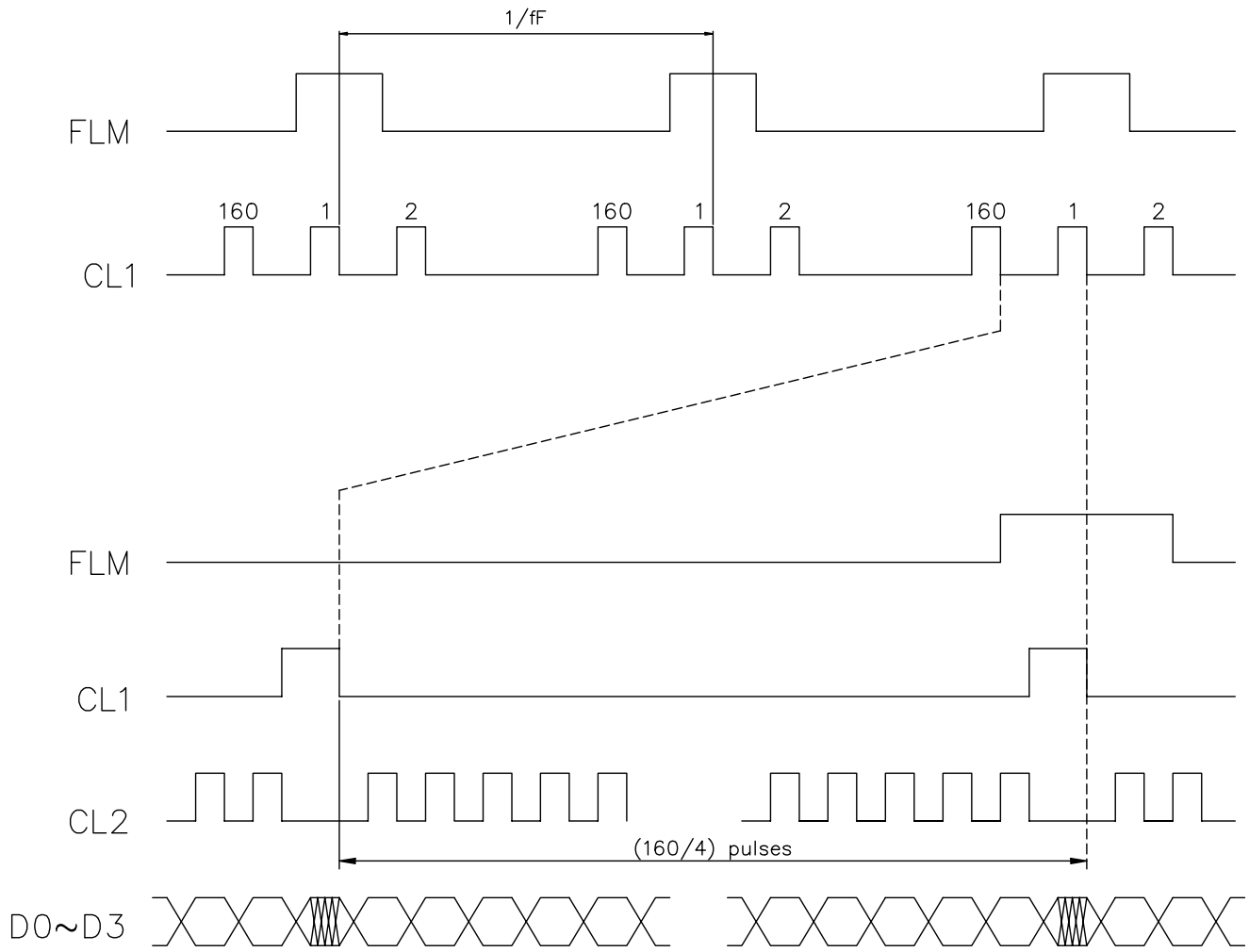
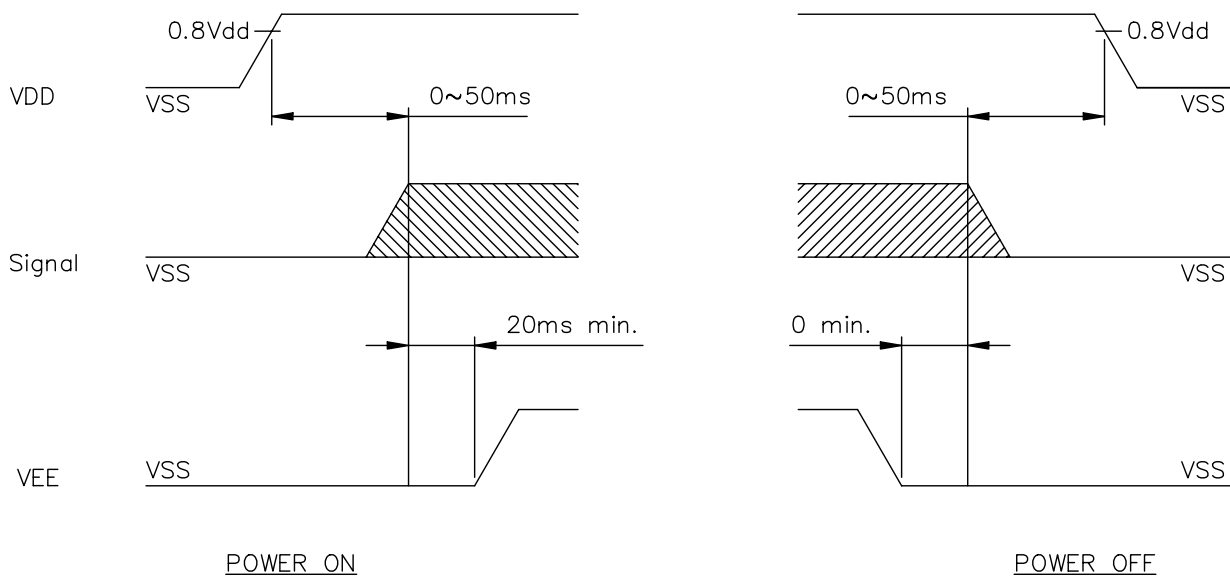

Fig . b Interface timing (COMMON)

8-2. TIMING CHART OF INPUT SIGNAL



8-3. POWER ON/OFF TIMING



Missing pixels may occur when the LCM is driven beyond the above power interface timing sequence.

8-4. DISPLAY PATTERN

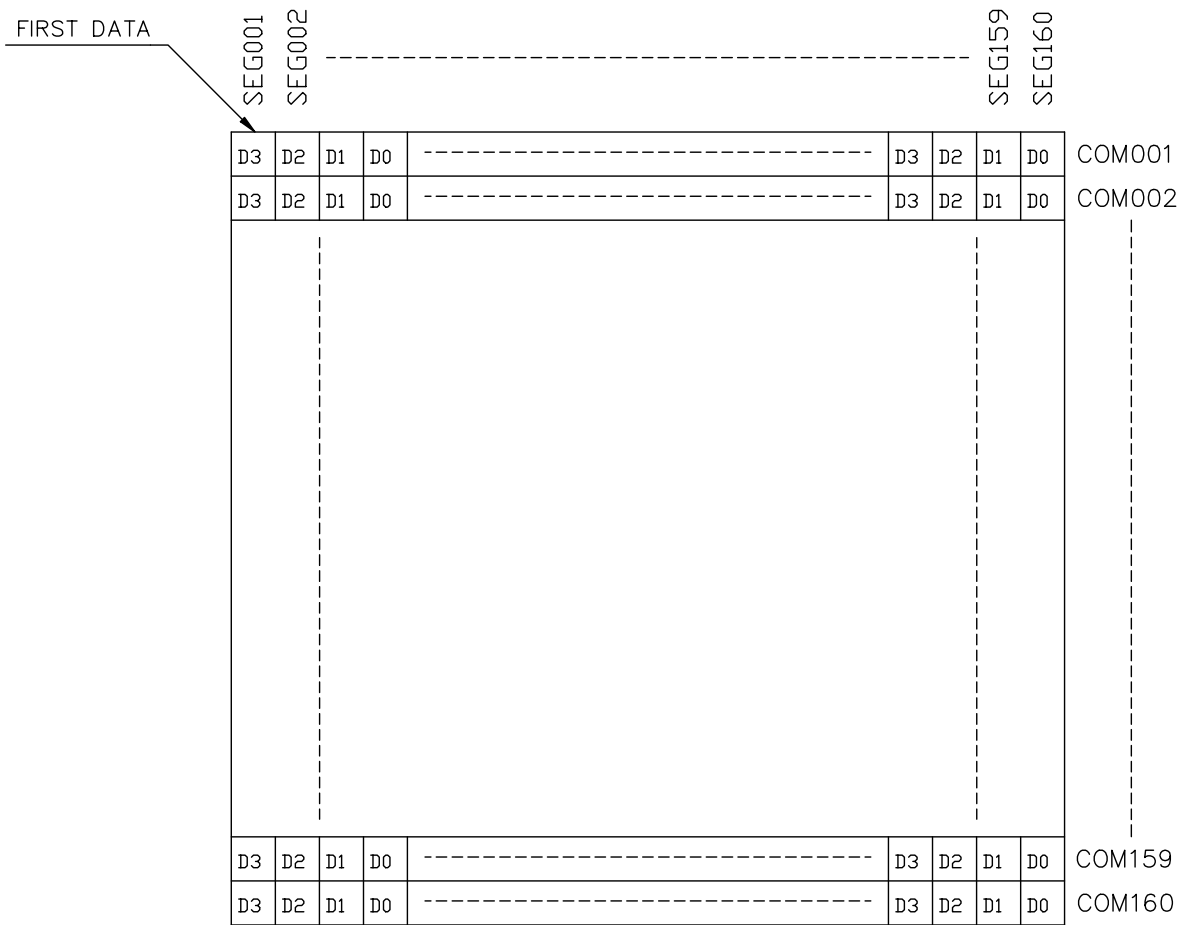

D0: (1•4)\(1•8)(160•160)
 D1: (1•3)\(1•7)(160•159)
 D2: (1•2)\(1•6)(160•158)
 D3: (1•1)\(1•5)(160•157)

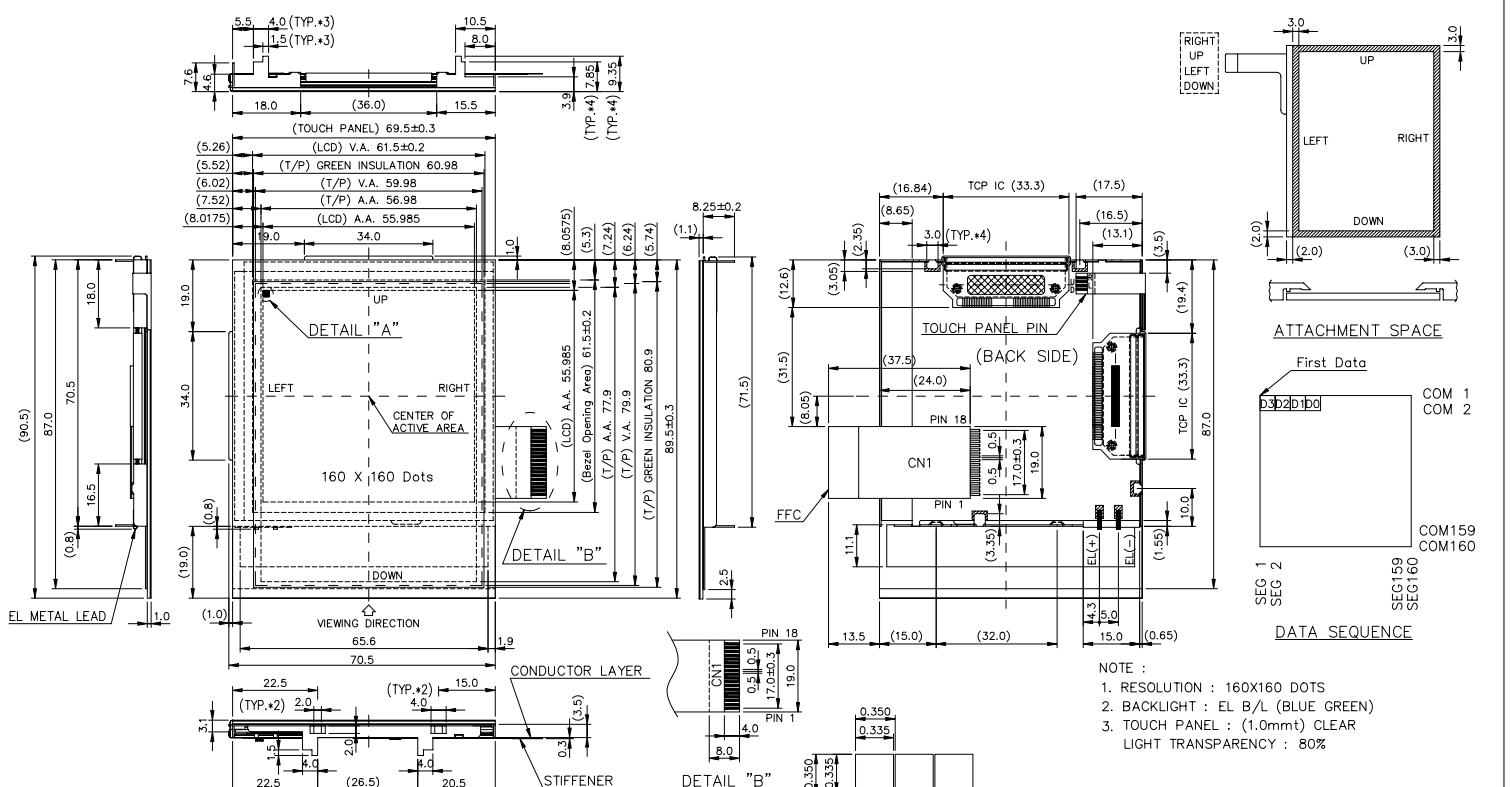

INTERFACE CONNECTION(CN1)

Pin No.	Symbol	Function	Pin No.	Symbol	Function
1	VSS	Power Supply (0V)	10	D2	H/L Display Data
2	FLM(EI02)	First Line Mark for Common Scan	11	D1	H/L Display Data
3	CL1(LP)	H → L DATA Latch Pulse	12	D0	H/L Display Data
4	CL2(XCK)	Clock Pulse for Segment shift register	13	LEFT	Touch Panel Connection
5	M(FR)	H/L Frame Reverse Signal	14	UP	
6	VDD	H/L Supply for logic (+3.3V)	15	RIGHT	
7	EL ON	EL Back Light ON/OFF ("H"=ON,"L"=OFF)	16	DOWN	
8	VEE	Power Supply for LCD	17	VSS	Power Supply (0V)
9	D3	H/L Display Data	18	BATTERY(+)	Power Supply For EL Backlight

TOLERANCE LIST(S)

DIMENSION	TOLERANCE
$L \leq 6$	± 0.25
$6 < L \leq 18$	± 0.3
$18 < L \leq 50$	± 0.4
$50 < L \leq 125$	± 0.5
$125 < L$	± 0.6

AZ DISPLAYS, INC.

AGM1616B

REV. NO.	DESCRIPTION	DATE	DESIGN	CHECK	APPROVE	DWG NO.	NAME	DATE	THIRD ANGLE P
						M4103-D114A	J.P. Weng	90.07.11	SCALE UNIT
							Ping Ping	90.07.09	1/1 mm