

# AZ Displays, Inc.

## 1. MECHANICAL DATA

(1) Product No.	<b>AGM2412B</b>
(2) Module Size	170.0 (W)mm x 102.0 (H)mm x MAX 14.0 (D)mm
(3) Dot Size	0.47 (W)mm x 0.47 (H)mm
(4) Dot Pitch	0.5 (W)mm x 0.5 (H)mm
(5) Number of Dots	240 (W) x 128 (H)Dots
(6) Duty	1/128
(7) LCD Display Mode	STN: <input type="checkbox"/> Gray Mode <input type="checkbox"/> Yellow Mode <input type="checkbox"/> Blue Mode FSTN: <input type="checkbox"/> Black and White(Normal White/Positive Image) <input type="checkbox"/> Black and White(Normal Black/Negative Image)
(8) Viewing Direction	Rear Polarizer: <input type="checkbox"/> Reflective <input type="checkbox"/> Transflective <input type="checkbox"/> Transmissive <input type="checkbox"/> 6 O'clock <input type="checkbox"/> 12 O'clock <input type="checkbox"/> ____O'clock
(9) Backlight	CCFL
(10) Weight	220 g

# AZ Displays, Inc.

## 2. ABSOLUTE MAXIMUM RATINGS

### (1) ELECTRICAL ABSOLUTE RATINGS

GND=0V

ITEM	SYMBOL	MIN	MAX	UNIT	COMMENT
Power Supply for Logic	VDD-GND	0	5.5	V	
Power Supply for LC Drive	VDD-VEE	0	24.0	V	
Input Voltage	VI	GND	VDD	V	
CCFL Driving Voltage	VFL	0	500	Vrms	
CCFL Input Current	IFL	-	7.0	mArms	
Static Electricity	-	-	-	-	Note 1

Note 1 LCM should be grounded during handling.

### (2) ENVIRONMENTAL ABSOLUTE MAXIMUM RATINGS

ITEM	NORMAL TEMP.				WIDE TEMP.			
	OPERATING		STORAGE		OPERATING		STORAGE	
	MIN.	MAX.	MIN.	MAX.	MIN.	MAX.	MIN.	MAX.
Ambient Temperature	0	50	-20	70	-20	70	-30	80
Humidity (Without Condensation)	Note 2,4		Note 3,4		Note 4,5		Note 4,6	

Note 2  $T_a \leq 50^\circ\text{C}$  : 85% RH max

$T_a > 50^\circ\text{C}$  : Absolute humidity must be lower than the humidity of 85%RH at  $50^\circ\text{C}$

Note 3  $T_a$  at  $-20^\circ\text{C}$  will be < 48hrs, at  $70^\circ\text{C}$  will be < 120hrs

Note 4 Background color changes slightly depending on ambient temperature. This phenomenon is reversible.

Note 5  $T_a \leq 70^\circ\text{C}$  : 75%RH max.

$T_a > 70^\circ\text{C}$  : Absolute humidity must be lower than the humidity of 75%RH at  $70^\circ\text{C}$

Note 6  $T_a$  at  $-30^\circ\text{C}$  will be < 48hrs, at  $80^\circ\text{C}$  will be < 120hrs

# AZ Displays, Inc.

## 3.0 ELECTRICAL CHARACTERISTICS

ITEM	SYMBOL	CONDITION	MIN.	TYP.	MAX.	UNIT	
Logic Circuit Power Supply	VDD-GND	-	4.5	5.0	5.5	V	
LCD Driver Power Supply (Normal Temp. LCM)	VDD-VEE	VDD=5.0V 1/13 Bias	0°C	-	19.9	21.1	V
			25°C	17.8	18.5	19.2	V
			50°C	16.6	17.0	-	V
LCD Driver Power Supply (Wide Temp. LCM)	VDD-VEE	VDD=5.0V 1/13 Bias	-20°C	-	20.8	21.6	V
			0°C	19.0	19.8	20.4	V
			25°C	18.9	19.7	20.3	V
			50°C	18.8	19.6	20.2	V
			70°C	18.1	18.9	-	V
Input Voltage	VIH	H level	0.7VDD	-	VDD	V	
	VIL	L level	GND	-	0.3VDD	V	
Power Consumption For LCD	Pd	VDD = 5.0V VEE = -13.5V	-	80	-	mW	
Supply Current (LCD)	IDD	VDD = 5.0V VEE = -13.5V	-	8.6	-	mA	
	IEE		-	2.7	-		
CCFL Starting Voltage	VFLS	-	-	900	-	Vrms	
CCFL Driving Voltage	VFLD	-	-	450	-	Vrms	
CCFL Driving Current	IFLD	VFLD = 450Vrms fFL = 30kHz					
CCFL Driving Frequency	fFL	-	15	30	50	KHZ	

## 3.1 BRIGHTNESS CHARACTERISTICS

VDD: 5V VDD-VEE: 19.1V VDD-VEE: 19.1V CCFL CONDITION at ABOVE TABLE

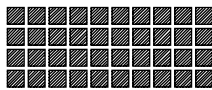
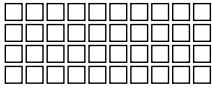
ITEM	CONDITION	MIN.	TYP.	MAX.	UNIT
BRIGHTNESS of LCM		-	5.27	-	cd/m <sup>2</sup>
		-	124.0	-	cd/m <sup>2</sup>

# AZ Displays, Inc.

## 4. OPTICAL CHARACTERISTICS

(FOR NORMAL TEMPERATURE MODE LCM)

AT V<sub>OP</sub>

ITEM MODE		Cr(Contrast Ratio)		$\theta$ (Viewing Angle)		$\phi$ (Viewing Angle)	
		25℃		25℃		25℃	
		MIN.	TYP.	MIN.	TYP.	MIN.	TYP.
R	A	—	—	—	—	—	—
	C	—	—	—	—	—	—
	J	4	6	40	60	25	35
S	A	—	—	—	—	—	—
	C	—	—	—	—	—	—
	J	3.5	6	40	55	20	30
T	C	—	—	—	—	—	—
	E	3	6	35	65	25	40
	G	6	15	45	90	30	50
note		NOTE6		NOTE5			

note:

R: REFLECTIVE  
S: TRANSFLECTIVE  
T: TRANSMISSIVE  
A: GRAY

C: YELLOW  
E: BLUE  
G: NORMALLY BLACK  
J: NORMALLY WHITE

AT  $\phi=0^\circ$   $\theta=0^\circ$

ITEM	SYMBOL	CONDITION	MIN.	TYP.	MAX.	UNIT	NOTE
Response Time (rise)	Tr	0℃	—	500	1000	ms	NOTE 2
		25℃	—	120	240		
		50℃	—	70	140		
Response Time (fall)	Tf	0℃	—	700	1200	ms	NOTE 2
		25℃	—	140	260		
		50℃	—	80	150		

# AZ Displays, Inc.

(FOR WIDE TEMPERATURE MODE LCM)

AT V<sub>OP</sub>

ITEM  MODE		Cr(Contrast Ratio)		$\theta$ (Viewing Angle)		$\phi$ (Viewing Angle)	
		25°C		25°C		25°C	
		MIN.	TYP.	MIN.	TYP.	MIN.	TYP.
R	C	3	4	40	60	28	35
	J	4	6.5	35	52	25	33
S	A	3	4	40	60	28	35
T	A	—	2.5	20	40	15	20
	E	3	4	40	60	15	25
	G	5	10	50	86	35	50
note		NOTE6		NOTE5			

note:

R: REFLECTIVE  
S: TRANSFLECTIVE  
T: TRANSMISSIVE  
A: GRAY

C: YELLOW  
E: BLUE  
G: NORMALLY BLACK  
J: NORMALLY WHITE

AT  $\phi=0^\circ$   $\theta=0^\circ$

ITEM	SYMBOL	CONDITION	MIN.	TYP.	MAX.	UNIT	NOTE
Response Time (rise)	Tr	-20°C	—	2200	4400	ms	NOTE 2
		0°C	—	440	880		
		25°C	—	120	240		
		50°C	—	60	120		
		70°C	—	50	100		
Response Time (fall)	Tf	-20°C	—	3000	5000	ms	NOTE 2
		0°C	—	550	1100		
		25°C	—	180	350		
		50°C	—	80	150		
		70°C	—	70	130		

# AZ Displays, Inc.

## 5. BLOCK DIAGRAM

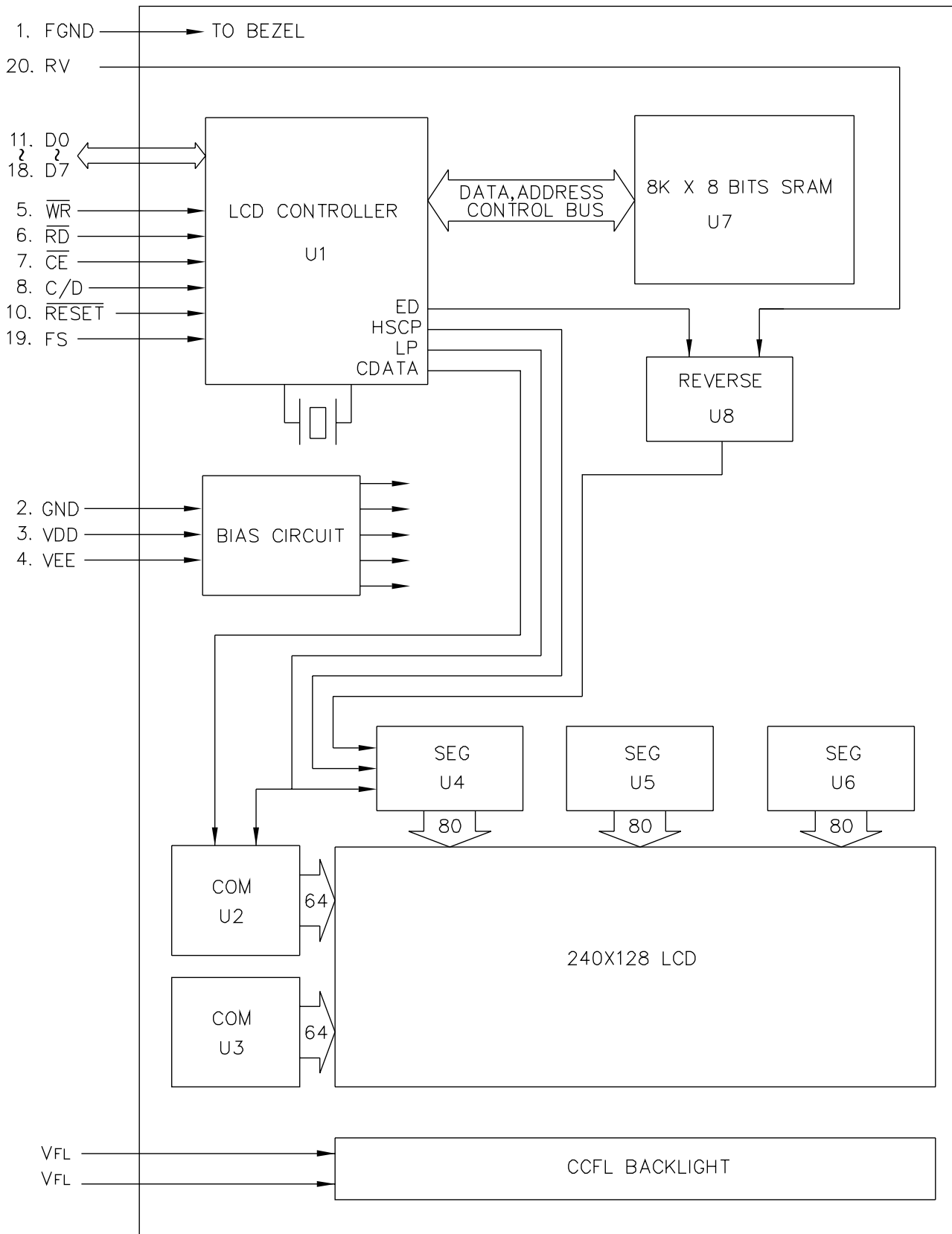

# AZ Displays, Inc.

## 6. INTERNAL PIN CONNECTION

PIN NO.	SYMBOL	FUNCTION
1	FGND	FRAME GROUND (0V)
2	GND	GROUND
3	VDD	POWER SUPPLY FOR LOGIC (+5V)
4	VEE	POWER SUPPLY FOR LC DRIVING
5	$\overline{WR}$	DATA WRITE
6	$\overline{RD}$	DATA READ
7	$\overline{CE}$	CHIP ENABLE
8	C/D	$\overline{WR}$ ="L",C/D="H" : COMMAND WRITE $\overline{WR}$ ="L",C/D="L" : DATA WRITE $\overline{RD}$ ="L",C/D="H" : STATUS READ $\overline{RD}$ ="L".C/D="L" : DATA READ
9	NC	NO CONNECTION
10	$\overline{RESET}$	CONTROLLER RESET
11	D0	DATA INPUT/OUTPUT
12	D1	DATA INPUT/OUTPUT
13	D2	DATA INPUT/OUTPUT
14	D3	DATA INPUT/OUTPUT
15	D4	DATA INPUT/OUTPUT
16	D5	DATA INPUT/OUTPUT
17	D6	DATA INPUT/OUTPUT
18	D7	DATA INPUT/OUTPUT
19	FS	FONT SELECT    CONNECT TO VDD : 6X8 PIXELS/CHARACTER CONNECT TO GND : 8X8 PIXELS/CHARACTER
20	RV	DISPLAY DATA REVERSE    RV=H : REVERSE DISPLAY RV=L : NORMAL DISPLAY

FL CONNECTOR : J.A.E./IL-G-5S-S3C2

PIN NO.	SYMBOL	FUNCTION
1	VFL	POWER SUPPLY FOR FL DRIVE
2	NC	NO CONNECTION
3	NC	NO CONNECTION
4	NC	NO CONNECTION
5	VFL	POWER SUPPLY FOR FL DRIVE

# AZ Displays, Inc.

## 7. POWER SUPPLY

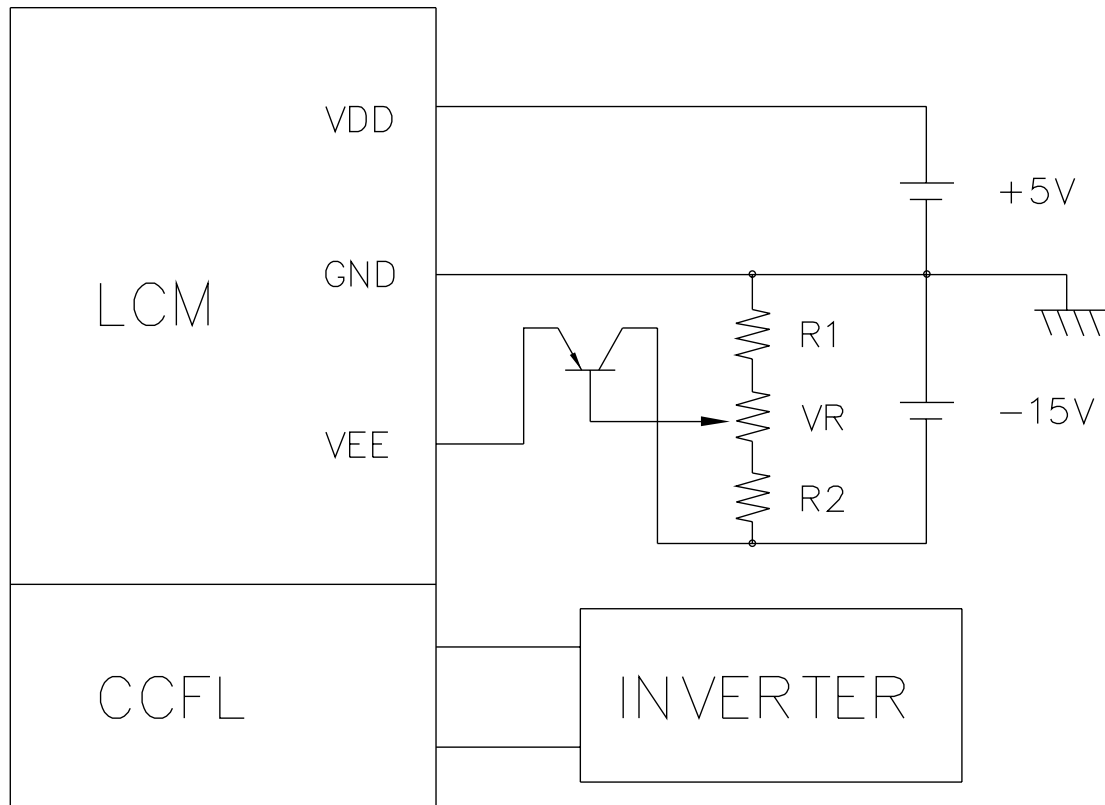

1.  $R1 + VR + R2 = 10K \sim 20K$
2. Recommended CCFL Inverter : TDK CXA-L10L



# AZ Displays, Inc.

## 8. TIMING CHARACTERISTICS

### 8-1 INTERFACE TIMING

VDD = 5V±10%

ITEM	ITEM	CONDITION	MIN.	MAX.	UNIT
C/D SET UP TIME	$t_{CDS}$	Fig.	100	—	ns
C/D HOLD TIME	$t_{CDH}$	Fig.	10	—	ns
$\overline{CE}, \overline{RD}, \overline{WR}$ CLOCK WIDTH	$t_{CP}, t_{RP}, t_{WP}$	Fig.	80	—	ns
DATA SET UP TIME	$t_{DS}$	Fig.	80	—	ns
DATA HOLD TIME	$t_{DH}$	Fig.	40	—	ns
ACCESS TIME	$t_{ACC}$	Fig.	—	150	ns
DATA OUTPUT HOLD TIME	$t_{OH}$	Fig.	10	50	ns

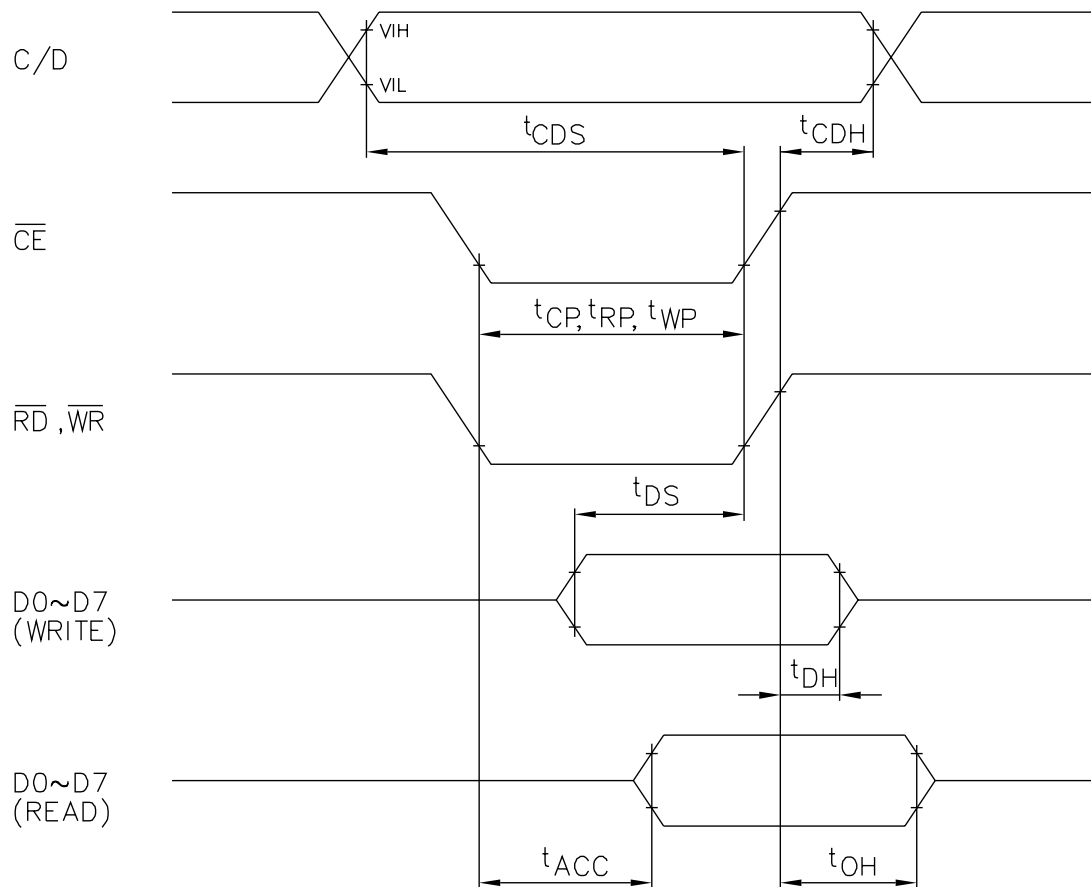

# AZ Displays, Inc.

## 8-2 POWER ON/OFF TIMING

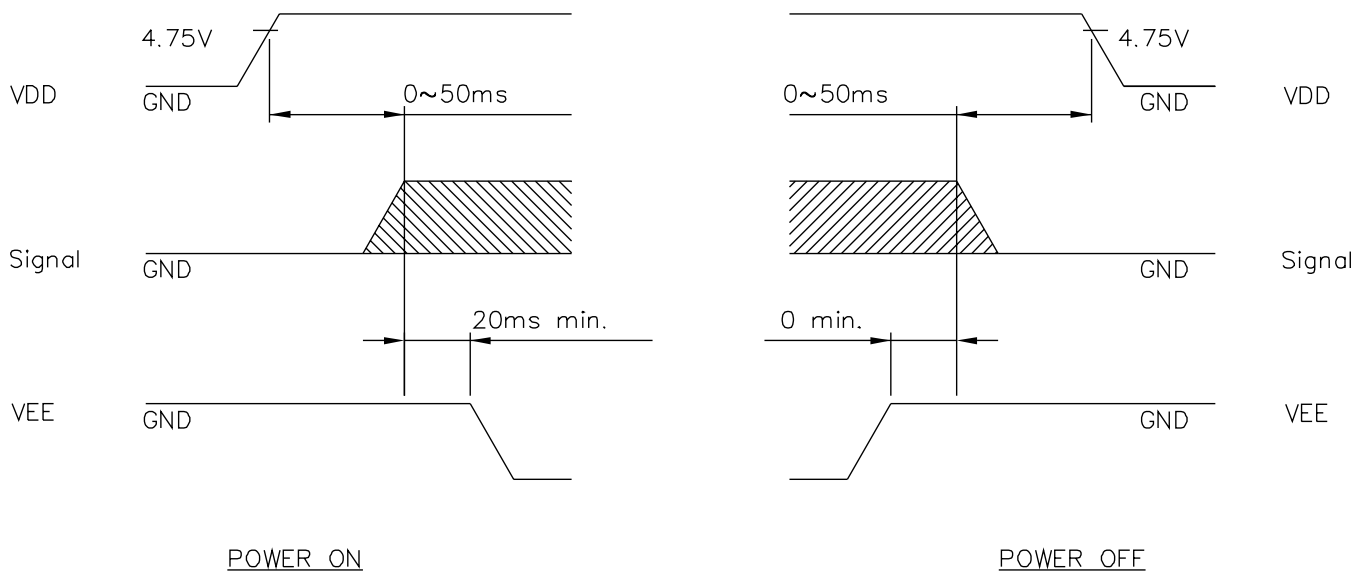

The missing pixels may occur when the LCM is driven beyond above power interface timing sequence.

## 9. DISPLAY PATTERN

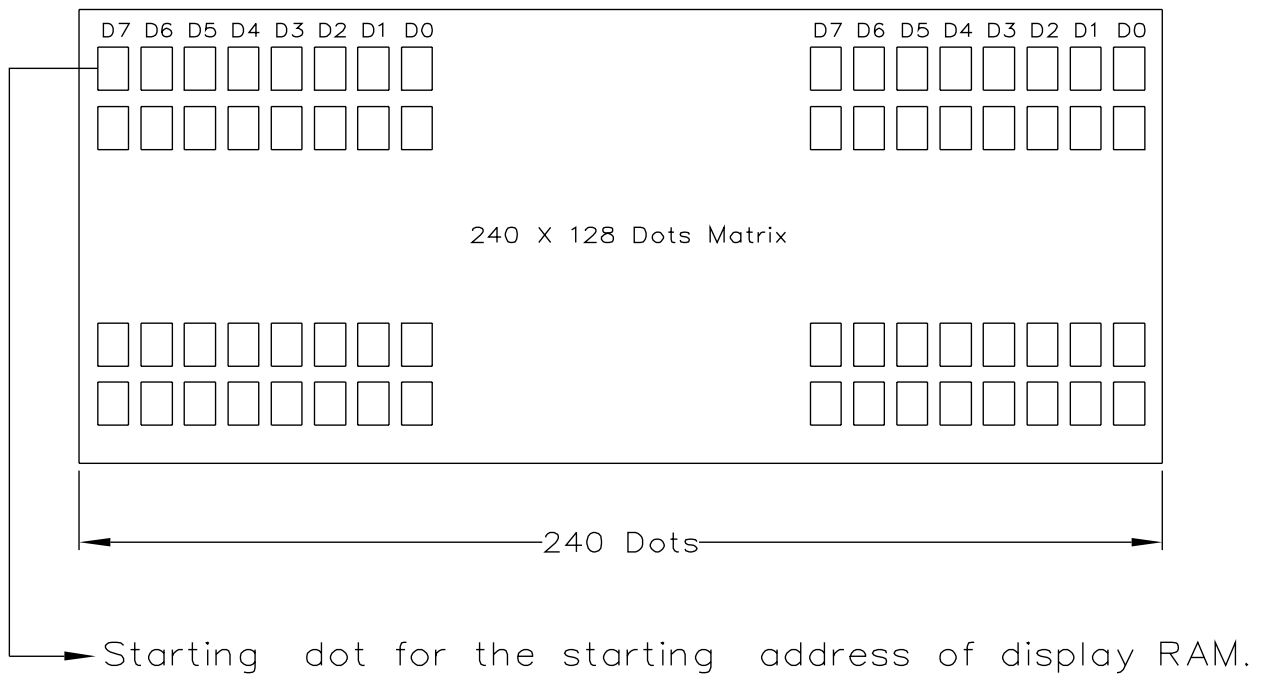

D0~D7 are 8 bits transmitted data, where D0 is LSB and D7 is MSB.

# AZ Displays, Inc.

(NOTE 4)

Definition of Viewing Direction

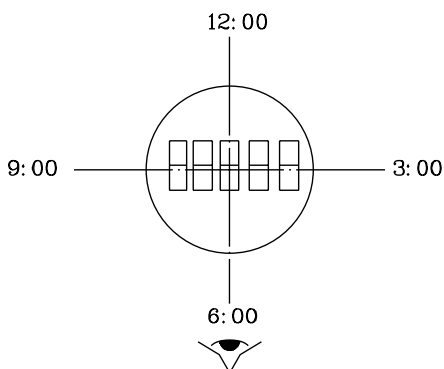

(NOTE 5)

Definition of Viewing Angle

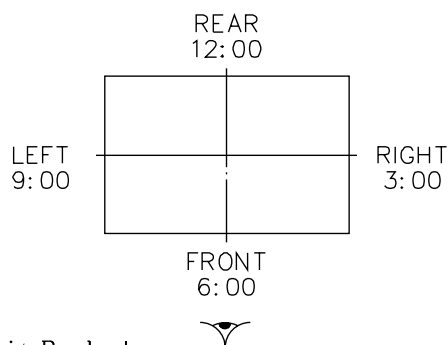
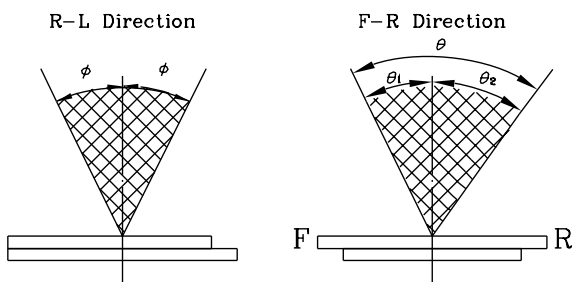

\*For This Product  
The Viewing Direction Is 6 O'clock  
So  $\theta_1 > \theta_2$

$$\theta = \theta_1 + \theta_2$$

\*Conditions

Operating Voltage :  $V_{op}$   
Frame Frequency : 70Hz  
Applying Waveform : 1/N duty 1/a bias  
Contrast Ratio : larger than 2

(NOTE 6)

Definition of Contrast Ratio (Cr)

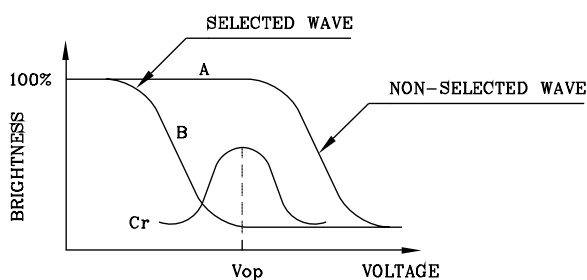

(positive type)

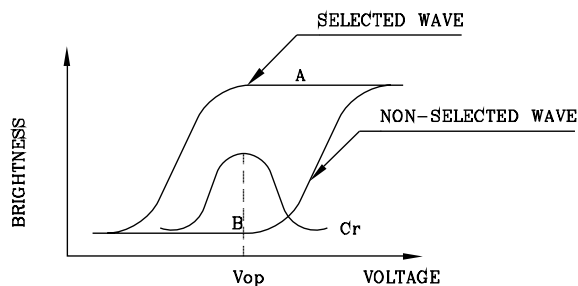

(negative type)

$$\text{Contrast Ratio : } Cr = A/B$$

\*Conditions

Viewing Angle : 0  
Frame Frequency : 70Hz  
Applying Waveform : 1/N duty 1/a bias

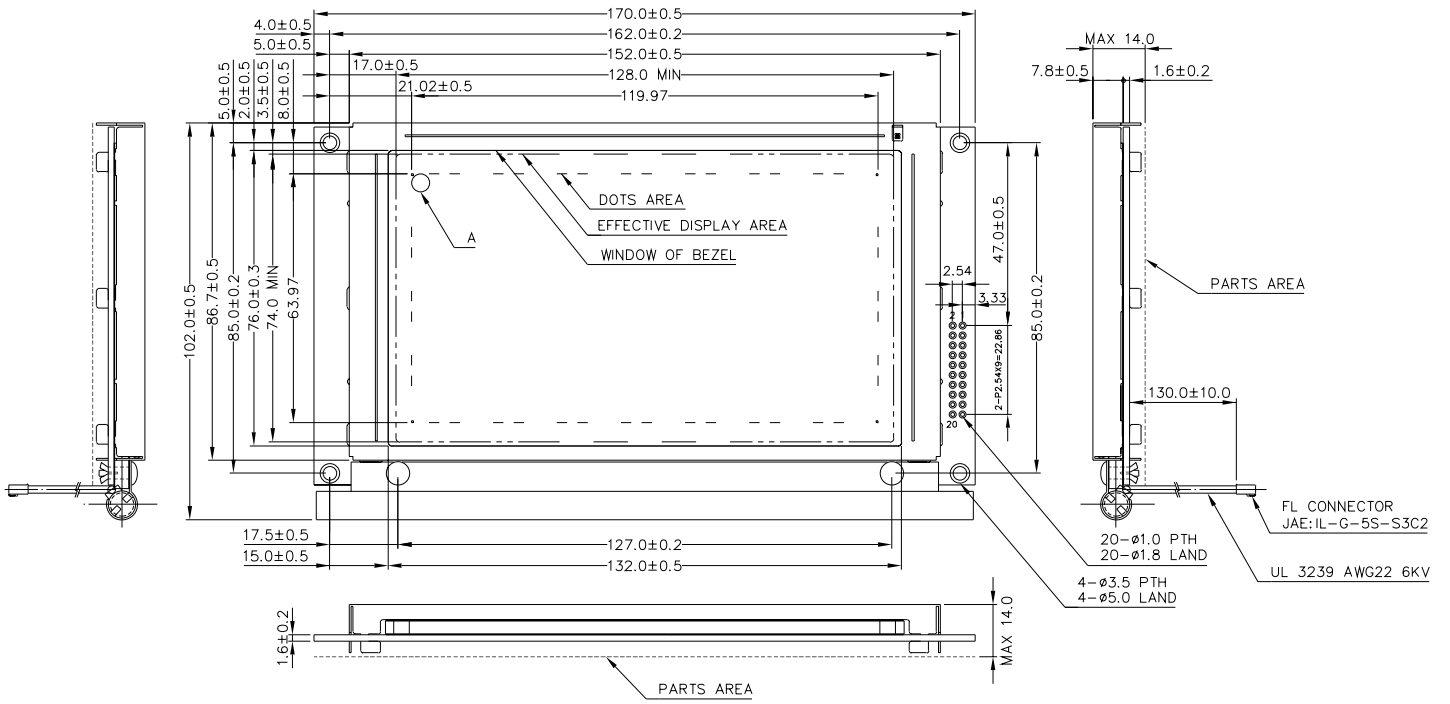

NOTES :

1. RESOLUTION : 240 X 128 Dots
2. CONTROLLER : T6963C(Toshiba)
3. DC/DC : Without
4. GENERAL TOLERANCE : ±0.5 mm

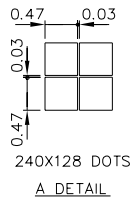

PIN NO.	1	2	3	4	5	6	7	8	9	10
SYMBOL	FGND	GND	VDD	VEE	WR	RD	CE	C/D	NC	RESET
PIN NO.	11	12	13	14	15	16	17	18	19	20
SYMBOL	D0	D1	D2	D3	D4	D5	D6	D7	FS	RV

AGM2412B		AZ DISPLAYS, INC.		
APPROVE	NAME	DATE	TITLE	
CHECK			DWG-NO	MB-X014XXX Rev.B
DESIGN			UNIT	mm
DRAW	MAY PING	87.10.28	THIRD ANGLE PROJECT	SCALE : 2/3