

# AZ DISPLAYS, INC.

## 1. MECHANICAL DATA

(1) Product No.	<b>AGM2412C</b>
(2) Module Size	144.0 (W)mm x 104.0 (H)mm x MAX10.8 (D)mm (EL B.L., NO B.L.) 144.0 (W)mm x 104.0 (H)mm x MAX14.9 (D)mm (LED B.L.)
(3) Dot Size	0.42 (W)mm x 0.42 (H)mm
(4) Dot Pitch	0.45 (W)mm x 0.45 (H)mm
(5) Number of Dots	240 (W) x 128 (H)Dots
(6) Duty	1/128
(7) LCD Display Mode	STN: <input type="checkbox"/> Gray Mode <input type="checkbox"/> Yellow Mode FSTN: <input type="checkbox"/> Black and White(Normal White/Positive Image) Rear Polarizer: <input type="checkbox"/> Reflective <input type="checkbox"/> Transflective <input type="checkbox"/> Transmissive
(8) Viewing Direction	<input type="checkbox"/> 6 O'clock <input type="checkbox"/> 12 O'clock <input type="checkbox"/> ___O'clock
(9) Backlight	<input type="checkbox"/> W/O <input type="checkbox"/> LED <input type="checkbox"/> EL
(10) Weight	W/O B.L. : 137g EL B.L. : 142g LED B.L. : 175g

Revised: September 26, 2001

## 2. ABSOLUTE MAXIMUM RATINGS

### (1) ELECTRICAL ABSOLUTE RATINGS

V<sub>SS</sub>=0V

ITEM	SYMBOL	MIN	MAX	UNIT	COMMENT
Power Supply for Logic	VDD-VSS	-0.3	5.5	V	
Input Voltage	V <sub>I</sub>	-0.3	VDD	V	
Static Electricity	-	-	-	-	Note 1

Note 1 LCM should be grounded during handling

### (2) ENVIRONMENTAL ABSOLUTE MAXIMUM RATINGS

ITEM	WIDE TEMP.			
	OPERATING		STORAGE	
	MIN.	MAX.	MIN.	MAX.
Ambient Temperature	-20	70	-30	80
Humidity (Without Condensation)	Note 4,5		Note 4,6	

Note 2 Ta ≤ 50°C : 85%RH max  
 Ta > 50°C : Absolute humidity must be lower  
 than the humidity of 85%RH at 50°C

Note 3 Ta at -20°C will be < 48hrs, at 70°C will be < 120hrs

Note 4 Background color changes slightly depending on ambient temperature.  
 This phenomenon is reversible.

Note 5 Ta ≤ 70°C : 75%RH max  
 Ta > 70°C : Absolute humidity must be lower  
 than the humidity of 75%RH at 70°C

Note 6 Ta at -30°C will be < 48hrs, at 80°C will be < 120hrs

## 3. ELECTRICAL CHARACTERISTICS

( VDD=5V±10% )

ITEM	SYMBOL	CONDITION	MIN.	TYP.	MAX.	UNIT	
Input Voltage	VIH	H level	0.8VDD	-	VDD	V	
	VIO	L level	0	-	0.2VDD	V	
Recommended LCM Driving Voltage (Wide Temp. LCM)	VCC-V0	Duty= 1/128	-20℃	19.9	20.3	20.7	V
			0℃	19.1	19.5	19.9	
		Bias= 1/13	25℃	18.5	18.9	19.3	
			50℃	17.7	18.1	18.5	
			70℃	16.9	17.3	17.7	
Power Supply Current	IDD	VDD = 5.0V  PATTERN: <div style="display: flex; justify-content: space-around; font-family: monospace; font-size: 0.8em;"> <span>□</span><span>■</span><span>□</span><span>■</span><span>□</span><span>■</span>  <span>■</span><span>□</span><span>■</span><span>□</span><span>■</span><span>□</span> </div>	-	48.5	-	mA	
LED Power Supply Current	ILED	VBL = 5.0V <sub>DC</sub> (RBL = 0Ω)	-	650	-	mA	
EL Power Supply Current	IEL	VEL = 72 V <sub>rms</sub> 400Hz	-	6.5	-	mA	

## 4. OPTICAL CHARACTERISTICS

### 4-1. WIDE TEMPERATURE MODE LCM

AT Vop

ITEM		Cr(Contrast Ratio)		$\theta$ (Viewing Angle)		$\phi$ (Viewing Angle)	
		25℃		25℃		25℃	
		MIN.	TYP.	MIN.	TYP.	MIN.	TYP.
R	J	—	14.5	—	94	—	82
S	J	—	9.5	—	76	—	80
NOTE		NOTE6		NOTE5			

AT  $\phi=0^\circ$   $\theta=0^\circ$

ITEM	SYMBOL	CONDITION	MIN.	TYP.	MAX.	UNIT	NOTE
Response Time (rise)	Tr	-20℃	—	2750	4125	ms	NOTE 2
		0℃	—	520	780		
		25℃	—	250	375		
		50℃	—	130	195		
		70℃	—	120	180		
Response Time (fall)	Tf	-20℃	—	2650	3975	ms	NOTE 2
		0℃	—	410	615		
		25℃	—	150	225		
		50℃	—	100	150		
		70℃	—	60	90		

NOTE :

R: REFLECTIVE  
 S: TRANSFLECTIVE  
 T: TRANSMISSIVE  
 A: GRAY

C: YELLOW  
 E: BLUE  
 G: NORMALLY BLACK  
 J: NORMALLY WHITE

(NOTE 1)

Definition of Operation Voltage(Vop)

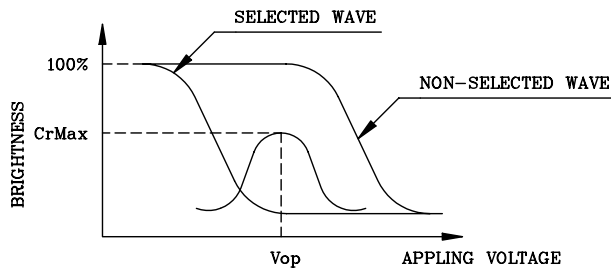

(positive type)

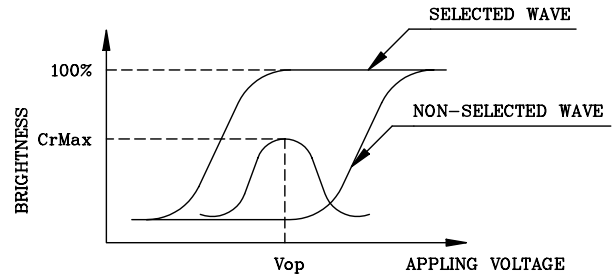

(negative type)

\*Conditions

- Viewing Angle : 0
- Frame Frequency : 70Hz
- Applying Waveform : 1/N duty 1/a bias

(NOTE 2)

Definition of Response Time(Tr,Tf)

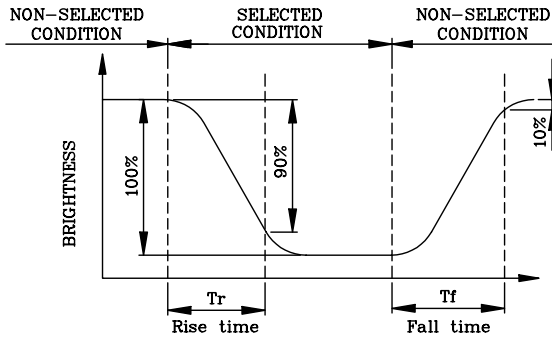

(positive type)

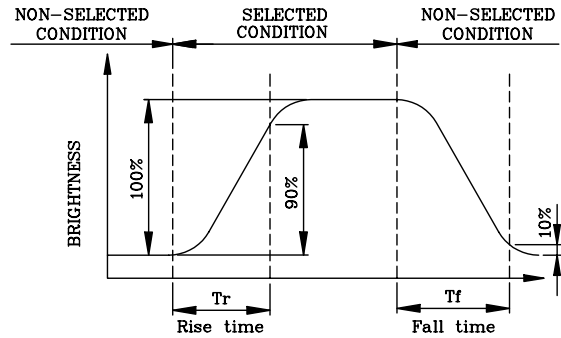

(negative type)

\*Conditions

- Operating Voltage : Vop
- Viewing Angle ( $\theta, \phi$ ) : (0,0)
- Frame Frequency : 70Hz
- Applying Waveform : 1/N duty 1/a bias

(NOTE 3)

Description of Measuring Equipment and Driving Waveforms

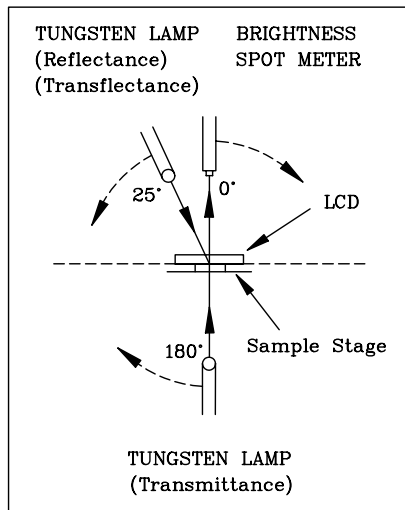

CONST.  
TEMP.  
CHAMBER

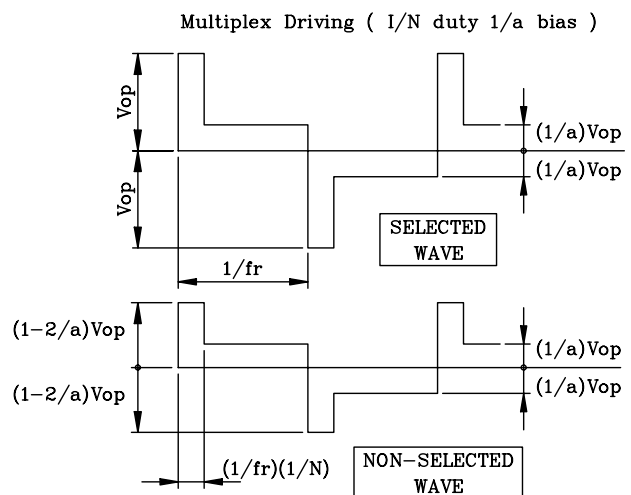

(NOTE 4)

Definition of Viewing Direction

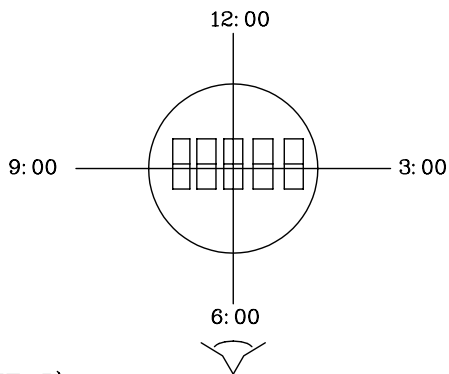

(NOTE 5)

Definition of Viewing Angle

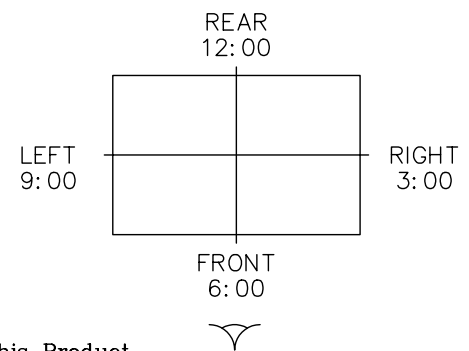
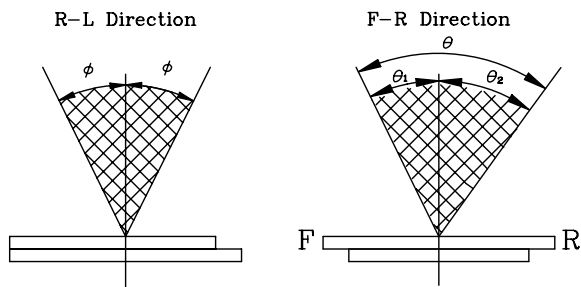

\*For This Product  
The Viewing Direction Is 6 O'clock  
So  $\theta_1 > \theta_2$

$$\theta = \theta_1 + \theta_2$$

\*Conditions

Operating Voltage : Vop  
Frame Frequency : 70Hz  
Applying Waveform : 1/N duty 1/a bias  
Contrast Ratio : larger than 2

(NOTE 6)

Definition of Contrast Ratio (Cr)

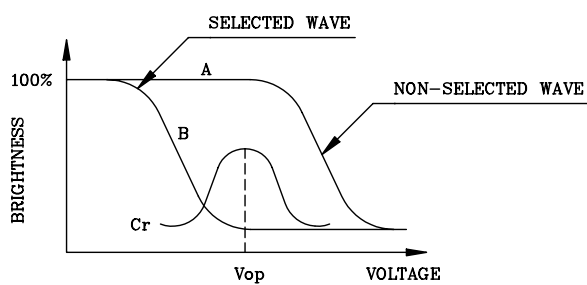

(positive type)

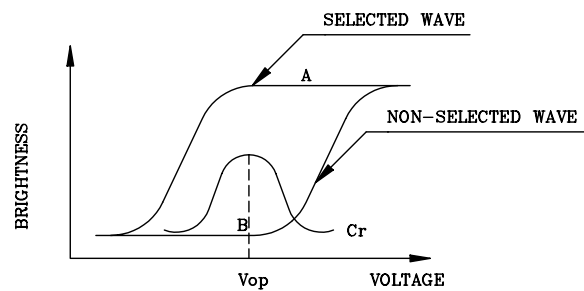

(negative type)

$$\text{Contrast Ratio : } Cr = A/B$$

\*Conditions

Viewing Angle : 0  
Frame Frequency : 70Hz  
Applying Waveform : 1/N duty 1/a bias

## 5. BLOCK DIAGRAM

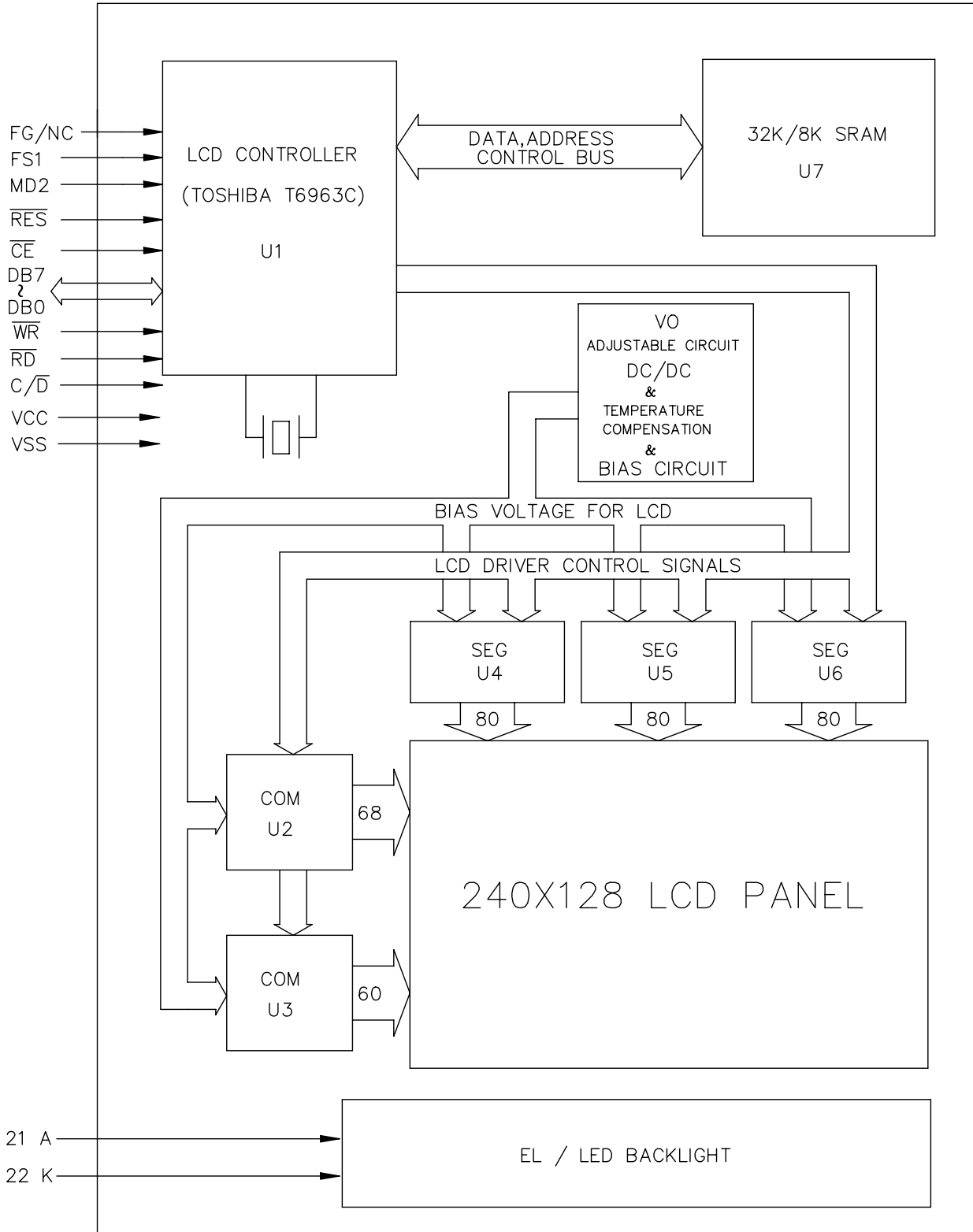

## 6. INTERNAL PIN CONNECTION

PIN NO.	SYMBOL	FUNCTION
1	VSS	GROUND (0V)
2	VCC	Logic Supply Voltage (+5V)
3	NC	—
4	C/ $\bar{D}$	"H" : Command "L" : DATA
5	$\bar{RD}$	DATA READ
6	$\bar{WR}$	DATA WRITE
7	DB0	Data bit 0
8	DB1	Data bit 1
9	DB2	Data bit 2
10	DB3	Data bit 3
11	DB4	Data bit 4
12	DB5	Data bit 5
13	DB6	Data bit 6
14	DB7	Data bit 7
15	$\bar{CE}$	Chip Enable
16	$\bar{RES}$	Reset
17	N.C.	—
18	MD2	Font Size Selection
19	FS1	Font Size Selection
20	FG/NC	Frame Ground or NC
21	A+	Power Supply for LED / EL B.L.
22	K-	



## 7. POWER SUPPLY

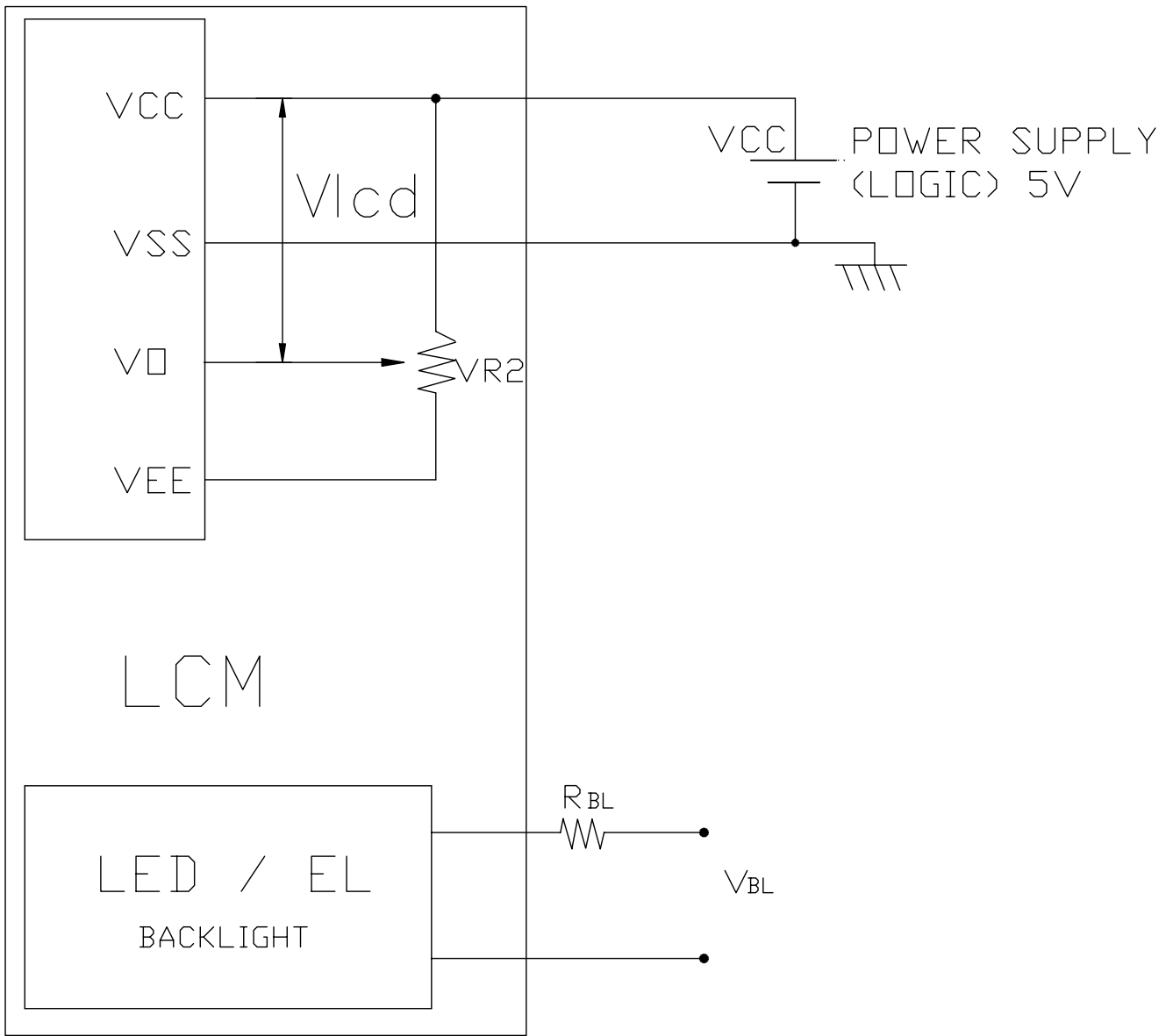

Recommended Value for  $V_{BL}$  and  $R_{BL}$

ITEM B.L. VALUE	$V_{BL}$	$R_{BL}$
LED	5V	0 $\Omega$
EL	110VAC 400HZ	0 $\Omega$

## 8-1. INTERFACE TIMING CHARACTERISTICS

(VCC=5.0V±10%,VSS=0V,Ta=-20 To 70°C)

ITEM	SYMBOL	CONDITION	MIN.	MAX.	UNIT
C/D SET UP TIME	$t_{CDS}$	Fig.	100	-	ns
C/D HOLD TIME	$t_{CDH}$	Fig.	10	-	ns
$\overline{CE}, \overline{RD}, \overline{WR}$ CLOCK WIDTH	$t_{CE}, t_{RD}, t_{WR}$	Fig.	80	-	ns
DATA SET UP TIME	$t_{DS}$	Fig.	80	-	ns
DATA HOLD TIME	$t_{DH}$	Fig.	40	-	ns
ACCESS TIME	$t_{ACC}$	Fig.	-	150	ns
DATA OUTPUT HOLD TIME	$t_{OH}$	Fig.	10	50	ns

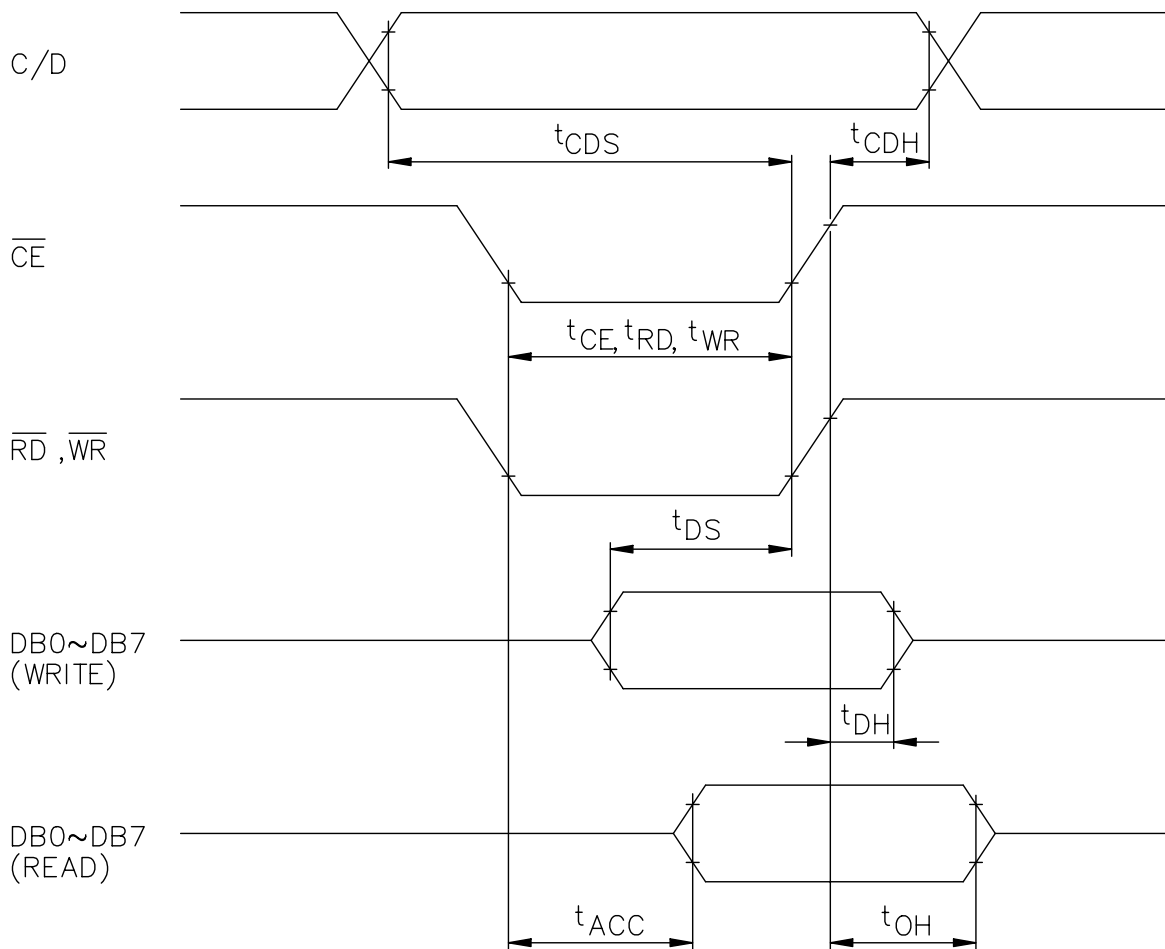
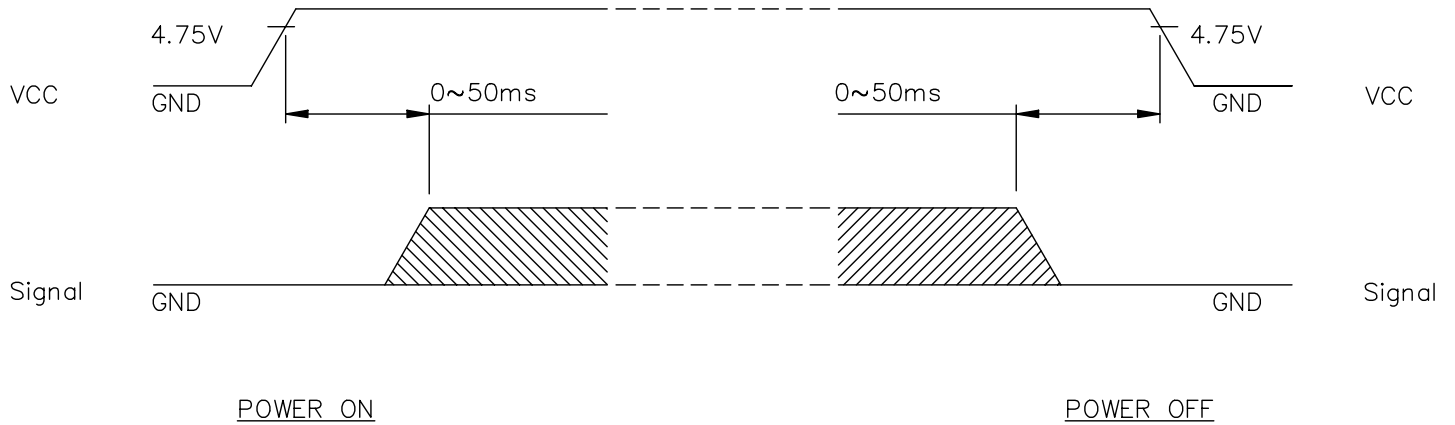

Fig. INTERFACE TIMING CHART

## 8-2. POWER ON/OFF TIMING CHARACTERISTICS



Missing pixels may occur when the LCM is driven beyond the above power interface timing sequence.

## 8-3. DISPLAY PATTERN

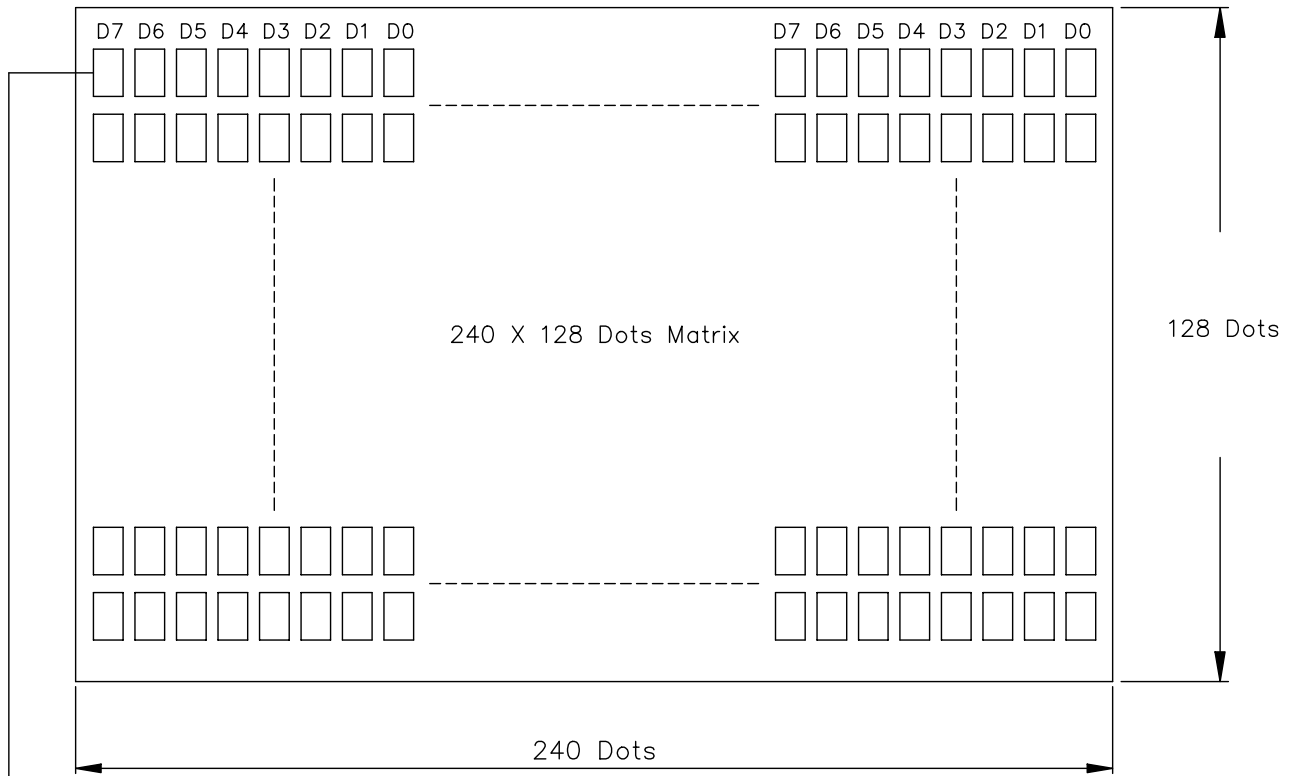

Starting dot for the starting address of display RAM.

DB0~DB7 are 8 bits transmitted data ,where DB0 is LSB and DB7 is MSB.

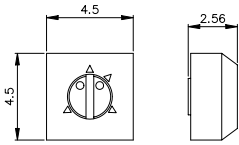

B DETAIL

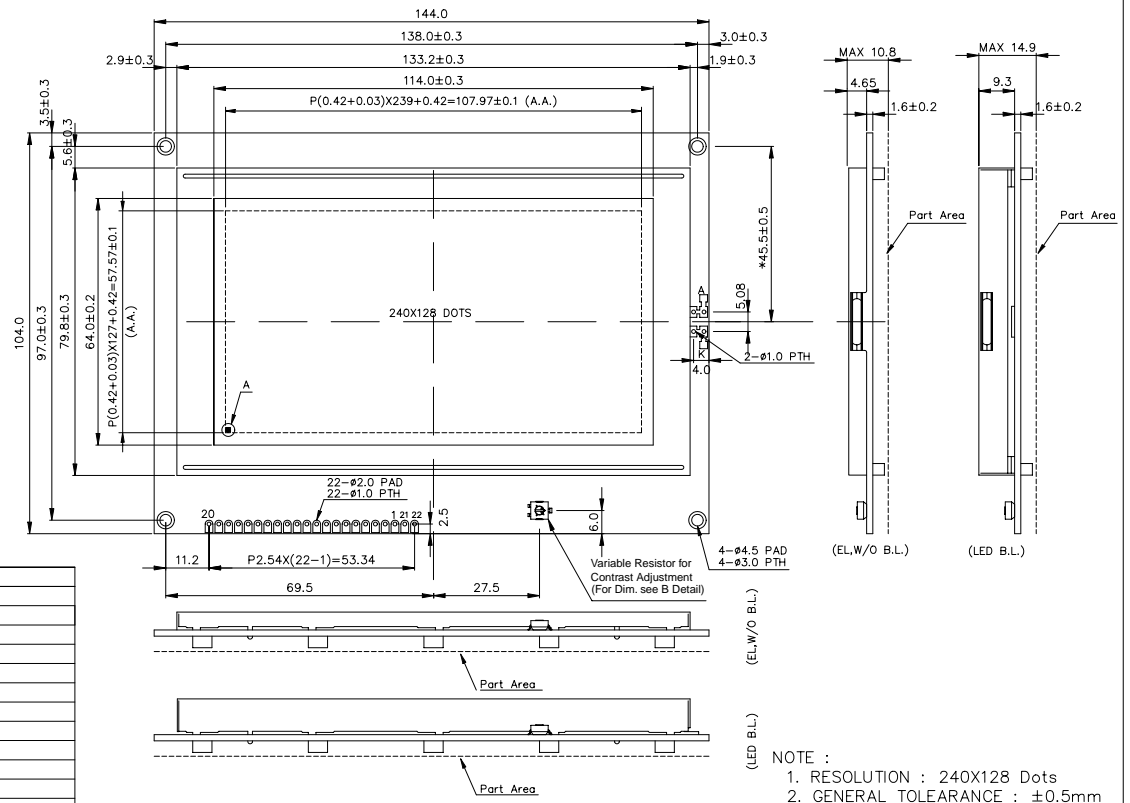

Pin No.	Symbol	Description
1	VSS	GROUND ( 0V )
2	VDD	Logic Supply Voltage (+5V)
3	N.C.	-
4	C/D	"H" : Command "L" : DATA
5	RD	DATA READ
6	WR	DATA WRITE
7	DB0	Data bit 0
8	DB1	Data bit 1
9	DB2	Data bit 2
10	DB3	Data bit 3
11	DB4	Data bit 4
12	DB5	Data bit 5
13	DB6	Data bit 6
14	DB7	Data bit 7
15	CE	Chip Enable
16	RES	Reset
17	N.C.	-
18	MD2	Font Size Selection
19	FS1	Font Size Selection
20	FG/NC	Frame Ground or NC
21	A+	Power Supply for LED/EL B.L.
22	K-	Power Supply for LED/EL B.L.

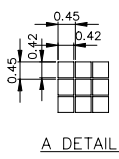

A DETAIL

- NOTE :
1. RESOLUTION : 240X128 Dots
  2. GENERAL TOLERANCE : ±0.5mm
  3. Controller : T6963C
  4. Logic Voltage : 5V.

	LM_EA_184_1_	AZ DISPLAYS, INC.		
	NAME	DATE	TITLE	AGM2412C
APPROVE	TONY CHOU	87.10.02	DWG-NO	MXAX184X1 Rev.A
CHECK	J.S.SHEU	87.10.02		
DESIGN	JACK LEE	87.10.02		
DRAW	MAY PING	87.10.02		
			UNIT	mm
			SCALE	1/1